



Safety Excess Flow Valve M-VF Series

Prevents uncontrolled flow of
corrosive and non-corrosive fluids
(Standard version)

Features

- High reliability
- Field adjustable
- Low pressure drop
- All mechanical
- Right angle flow

Description

The M-VF Series Safety Excess Flow Valves are engineered for fast automatic shut-off in case of line, hose or fitting failures protecting plant, personnel and instruments. Designed for protection of systems handling corrosive, toxic, radioactive and flammable materials; the valve will instantly detect surge in the system and stop fluid flow. When the break is repaired and pressure is equalized in the system, the valve will open to allow the fluid to flow through the system. The M-VF operates effectively with all fluids, liquids or gases.

Operation

As the fluid (liquid or gas) enters the valve, the pressure differential across the piston creates a venturi effect, accelerating the flow through the valve. At a preset flow rate, when the differential exceeds the magnetic attraction between the piston magnet and the adjusting screw magnet, the piston travels instantaneously over towards the output port, thereby shutting off the flow. When the pressure is equalized between both sides of the valve, the piston automatically returns to its previous adjusted flow set-point. The shut off point is field adjustable and this is achieved by turning the adjusting screw.

In case of positive shut off models, an elastomer O-ring fitted on the nose of the piston completely shuts off the flow once it rests on the seat and results in bubble tight closure. For resetting, bleed the upstream line to atmosphere to equalize the pressure as specified in the installation section. In the case of automatic reset model (controlled bleed), there is a controlled bleed as there is no O-ring present between the piston and the valve seat. When the flow of medium is turned off at the source, this controlled bleed permits equalization on two sides, and the piston travels back to its original position.

Applications

- Pollution control
- Leak detection
- Hydraulic lines
- Regulator protection
- Compressed Air and Gas system
- Gas analysers
- Sampling station operator protection
- Catastrophic failure protection

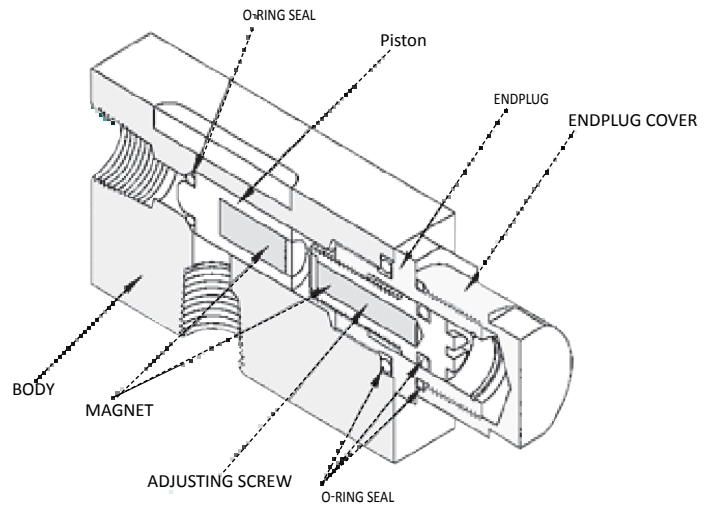

Illustrated is the M-VF Model with 1/4" ports.

Custom Versions Available

Malema welcomes the opportunity to apply its flow sensor experience to work for its customers. Please contact the factory for any special requirements; such as ports, extreme temperature and pressure capabilities, etc.

Measurement Specifications

Calibration Range *	Air : 0.0177 - 130 scfm Water : 0.0026 - 20 gpm * These ranges are over different valve sizes
Set Point Accuracy	±10% maximum
Repeatability	± 3%
Material Versions *	<ul style="list-style-type: none"> • Brass • 316 Stainless Steel * Other materials available upon request.
Port Sizes	<ul style="list-style-type: none"> • 1/8" • 1/4" • 3/8" • 1/2" • 3/4"

Standard Specifications by Materials

Part Name	Material	
Housing, End Plug and Adjusting Screw	Brass	316SS
Magnet in Adjusting Screw & Pistons	Alnico 5	
Piston	316SS	316SS
O-rings	Viton	
Pressure and Temperature Specifications		
Maximum Operating (psig)	1,500	3,000
Burst (psig)	3,000	5,000
Maximum Operating Temperature	149°C (300°F)	149°C (300°F)

Flow Range Table

Port Size (FNPT)	Shut Off Range (Air/scfm)	Shut Off Range (Water/gpm)
1/8"	0.0177 - 5	0.00264 - 0.8
1/4"	0.12 - 35	0.0264 - 3.5
3/8"	3 - 60	0.1 - 4
1/2"	5 - 75	0.5 - 10
3/4"	15 - 130	1.0 - 20

Installation and Flow Rate Adjustment

1. The preferred mounting orientation for the valve is in the horizontal position, although it can be mounted vertically.
2. Turn the adjusting screw fully counter-clockwise.
3. Connect hose or piping to outlet and operate at maximum flow rate (liquid or gas).
4. Turn the adjusting screw clockwise until the valve actuates and shuts off flow.
5. Turn the flow off. The valve will automatically reset because of its controlled bleed. For positive shut-off models, equalize the pressure on both sides of the valve. The valve will reset as the pressure is equalized and automatically return to its previously adjusted flow setting.
6. Turn the adjusting screw (one turn) counter-clockwise and system is ready to function.

Note: In high pressure environments, step 4 may need to be done iteratively under no flow conditions, after which flow can be resumed to test for valve actuation.

Maintenance

It is beneficial to have adequate filtration in the system prior to the valve as otherwise, its functioning may be hampered by large particles interfering with the travel of the piston. Using an adjustable wrench, gently remove the end-plug from the valve body. Examine the piston, the O-rings, and the surfaces of the valve bore and clean with trichloroethane if necessary, prior to reassembling (Replacement parts are available on request).

Adequate sealing methods must be used at all connections to the valve to prevent leakage.

Dimensional Drawings

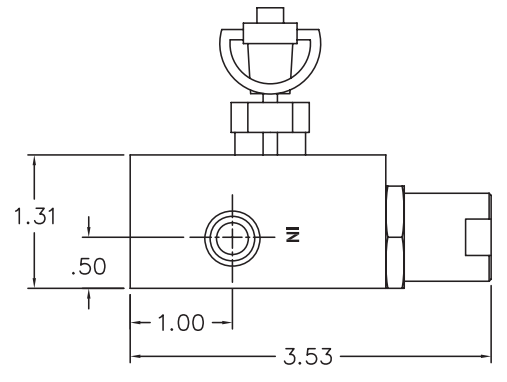
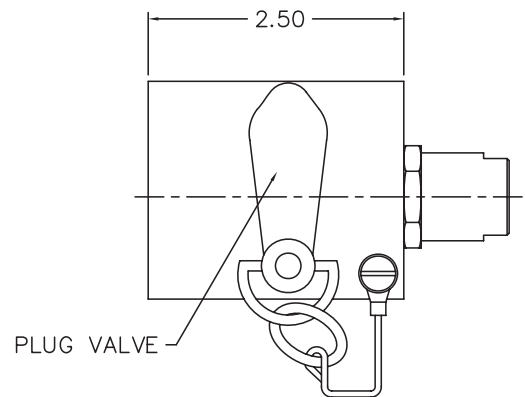
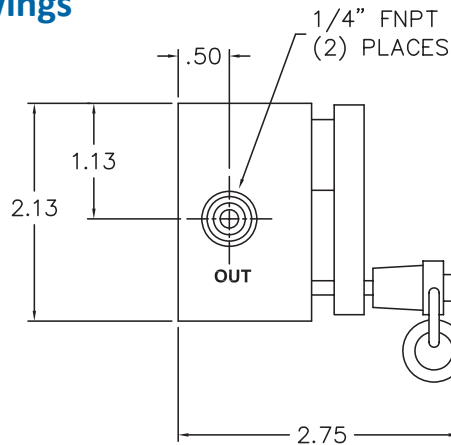

		Port Size				
		1/8"	1/4"	3/8"	1/2"	3/4"
"A"	IN	2-7/8"	3-1/2"	3-1/2"	4-3/4"	5-3/4"
	MM	73.03	88.90	88.90	120.65	146.05
"B"	IN	1-1/4"	1-1/2"	1-1/2"	2"	2-1/4"
	MM	31.75	38.1	38.1	50.8	57.15
"C"	IN	1-1/16"	1"	1"	1-1/4"	1-5/8"
	MM	17.46	25.4	25.4	31.75	41.28
"D"	IN	3/8"	1/2"	1/2"	5/8"	5/8"
	MM	9.53	12.7	12.7	15.88	15.88
"E"	IN	3/4"	1"	1"	1-1/4"	1-1/4"
	MM	19.05	25.4	25.4	31.75	31.75
"F"	IN	5/8"	1"	1"	1-3/8"	1-3/8"
	MM	15.88	25.4	25.4	34.93	34.93

Cut Dimensional Drawings

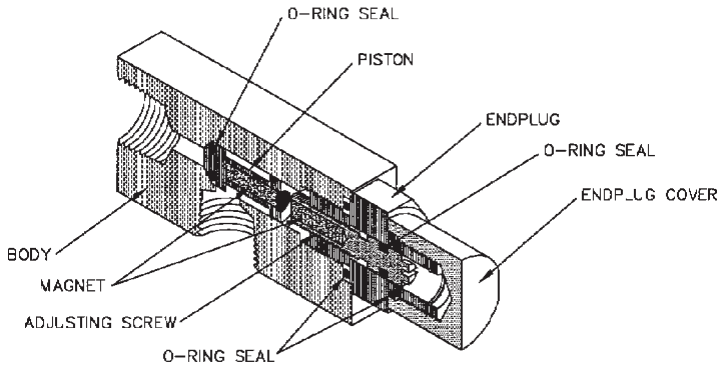

Illustrated is the Standard M-VF Model with 1/8" ports.

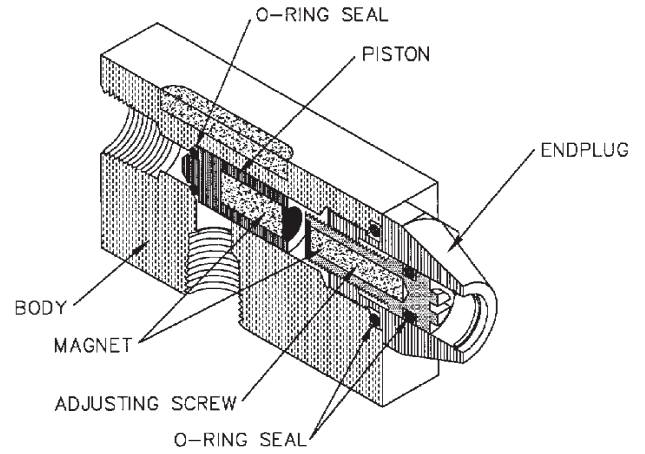

Illustrated is the Standard M-VF Model with 1/4" ports.

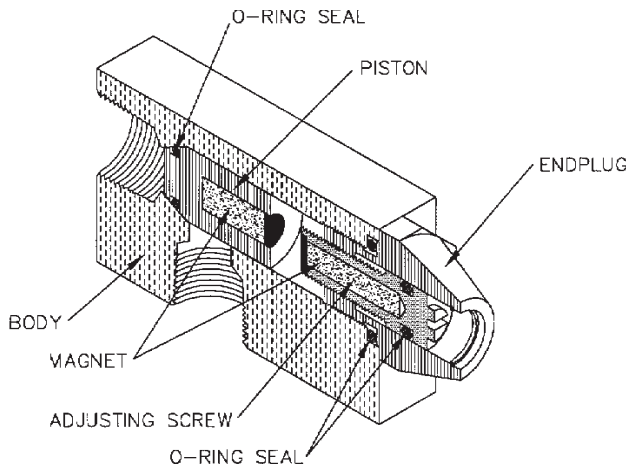

Illustrated is the Standard M-VF Model with 3/8" ports.

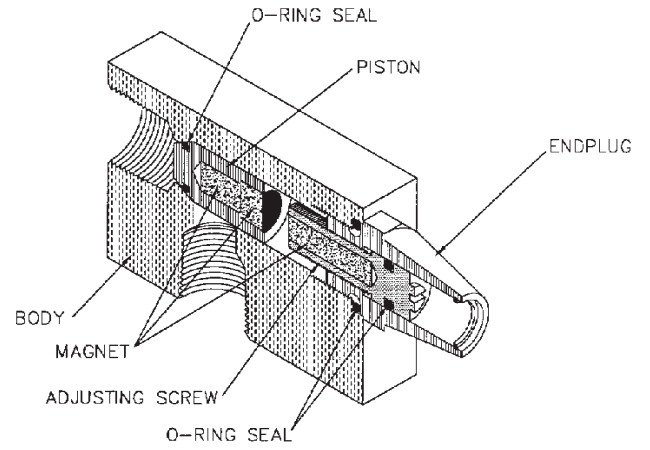

Illustrated is the Standard M-VF Model with 1/2" ports.

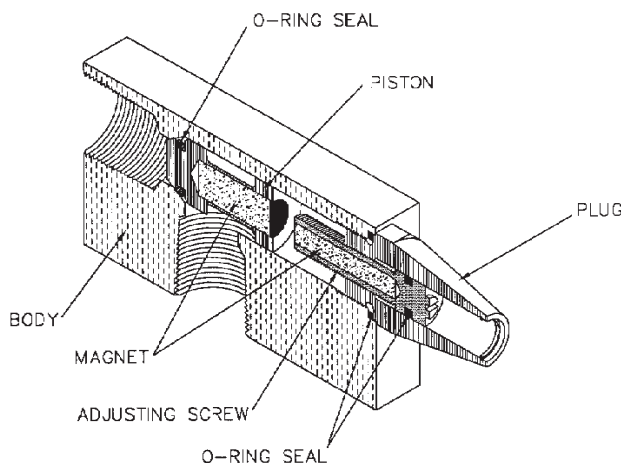

Illustrated is the Standard M-VF Model with 3/4" ports.

Ordering Information

Standard Part Numbering						Options				
M	-	Model	-	Material	Port	Shutoff	-	Reset*	Piston	Seals
M	-	VF	-	S	1	1	-	0	0	1
				B - Brass S - 316 Stain- less Steel	1 - 1/8" 2 - 1/4" 3 - 3/8" 4 - 1/2" 6 - 3/4"	1 - Positive Shutoff 2 - Bleed		0 - Standard 1 - Bleed to Atmos- phere 2 - Bleed to Sample Container through Barbed Tube 3 - Intrinsic Reset	0 - Standard* (316SS with epoxy) 1 - All 316SS (no epoxy)	0 - Standard (Viton®) 1 - Kalrez® 3 - Teflon® 4 - Silicone 5 - EPDM 6 - Butyl 7 - Nitrile

© 2017 Malema Engineering Corporation. All rights reserved.

Malema, Malema Sensors, and Malema Engineering Corporation are service marks of Malema Engineering Corporation. All other trademarks are property of their respective owners.

Malema supplies this publication for informational purposes only. While every effort has been made to ensure accuracy, this publication is not intended to make performance claims or process recommendations. Malema does not warrant, guarantee, or assume any legal liability for the accuracy, completeness, timeliness, reliability, or usefulness of any information, product, or process described herein. We reserve the right to modify or improve the designs or specifications of our products at any time without notice. For actual product information and recommendations, please contact your local Malema representative.