

SCREW PUMPS MEDIUM PRESSURE TYPE SMxT1 6B

Dry & submersible screw pumps for industrial applications - Working pressure 40 bar continuous

SMxT1 6B



40 bar program

SCREW PUMPS MEDIUM PRESSURE TYPE SMxT1 6B

Dry & submersible screw pumps for industrial applications - Working pressure 40 bar continuous

CHARACTERISTICS

The screw pumps are reliable, low noise and low cost; run without pulsation and guarantee a long life to your application.



USES

The screw pumps coupled together with external or immersed motors run quietly and without pulsation. Are used in hydraulic application and systems of every kind.

OPERATION

The screw pumps are positive displacement rotary pump with axial flow design. There are only three moving parts. The power rotor is the only driven part that extends outside the case. The idler screws actually act as sealing parts and are turned hydraulically by the fluid being pumped. There is only a rolling action between the drive screw and the idler ones. The rolling action eliminates noise and vibration.

TYPICAL APPLICATIONS

- Lube services (diesel engines, turbines, compressors, gears & gear boxes)
- Seal oil services (compressors, generators)
- Power Hydraulics (presses, machine tools, working machines rolling mill, injection moulding machines, dumping equipment, elevators, variable pitch propellers, hydraulic winches)
- Various & special applications for industrial and marine uses
- Food (chocolate, syrups, vegetal oils)
- Hydraulic governors
- Refinery & petrol chemical services
- Cooling
- Transfer services
- Fuel oil burners

SCREW PUMPS MEDIUM PRESSURE TYPE SMxT1 6B

Dry & submersible screw pumps for industrial applications - Working pressure 40 bar continuous

Detailed technical information

<i>Types</i>	Dry (SMT16B) or submersed (SMIT16B)
<i>Flanges</i>	ISO 3019/2 – IEC standard (for directed coupling with motor)
<i>Connections</i>	SAE 3000
<i>Installation position</i>	free for SMT 16B submerged (totally or partially) for SMIT 16B
<i>Drive loading</i>	No axial or radial loads
<i>Shaft rotation</i>	clockwise viewed at the shaft end
<i>Shaft speed</i>	From 500 to 3.600 rpm
<i>Model available</i>	20 – 32 – 40 – 45 – 55 – 60 – 70 – 80
<i>Flows</i>	From 8 up to 1.200 Lt/min (at 2.750 rpm)
<i>Outlet pressure</i>	40 bar continuous – 50 bar intermittent
<i>Inlet pressure</i>	Min. –0,7 / max. 3 bar
<i>Fluids</i>	mineral oil HLP e HLVP ecologic fluids HETG-HEPG-HEE synthetic fluid or emulsion: HFA oil-water emulsion - oil minimum 5% HFB water-oil emulsion ≥40% HFC water/glycole - water max 35 to 55% HFDR phosphate ester Lubrification high viscosity oils (*) Special synthetic fluid : MIL-H, SKYDROL, special on request
<i>Viscosity</i>	from 4 up to 2.000 mm ² /s
<i>Seals</i>	NBR, VITON, FPM, EPDM - Special on request
<i>Noise</i>	from 52 up to 68 dB(A) at 2.750 rpm Value based on ISO 4412 test procedure
<i>Pump body (standard)</i>	extruded aluminium alloy
<i>Pump body (special application)</i>	cast iron, carbon steel
<i>Screw</i>	steel for primary screw , cast iron for secondary screw
<i>Environment temperature</i>	From -20° up to +60°C
<i>Hydraulic temperature</i>	From -20° up to +180°C
<i>Filtration</i>	permissible degree of fluid contamination NAS to 1638 class 10 or ISO DIS 4406 - 19/16 Recommended filtration $\beta_{25} \geq 75$
<i>Maintenance</i>	No

(*) For high viscosity applications and/or oil-air emulsions, please check with us the suitable pump model

The data shown in the catalogue can change without notice.
For special applications □ please contact the main office.

SCREW PUMPS MEDIUM PRESSURE TYPE SMxT1 6B

Dry & submersible screw pumps for industrial applications - Working pressure 40 bar continuous

Component description

Hollow shaft pump

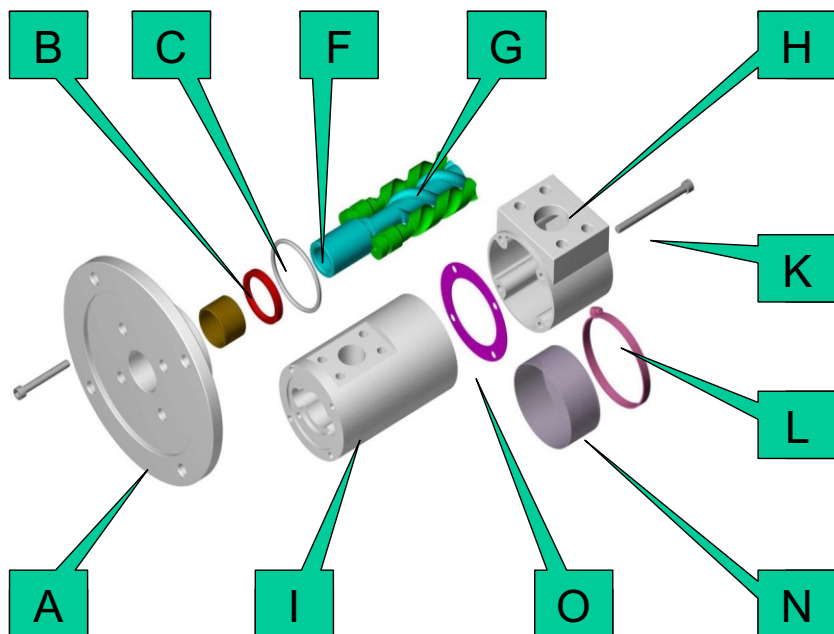

A	Mounting flange
B	Seals
C	O-ring seals
D	Seeger
E	Ball bearing (only for male shaft)
F	Main screw
G	Idler screw

Normal shaft pump

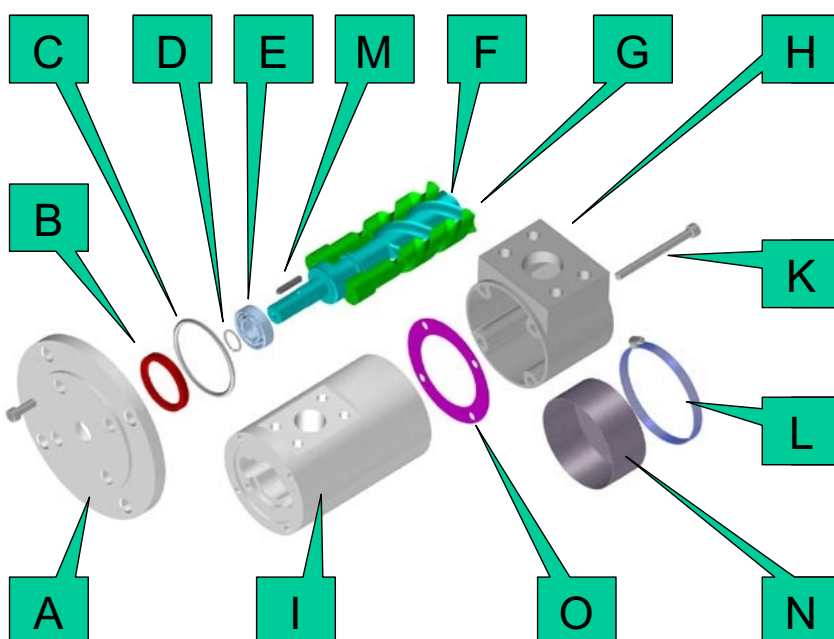

H	Suction cover (only for dry pump)
I	Body
K	TCEI screws
M	Key
N	Filter (only for submersible pump)
O	Plane gasket
L	Hose clamp

SCREW PUMPS MEDIUM PRESSURE TYPE SMxT16B

Dry & submersible screw pumps for industrial applications - Working pressure 40 bar continuous

Dimensional drawing – series SMT16B

Dry screw pump

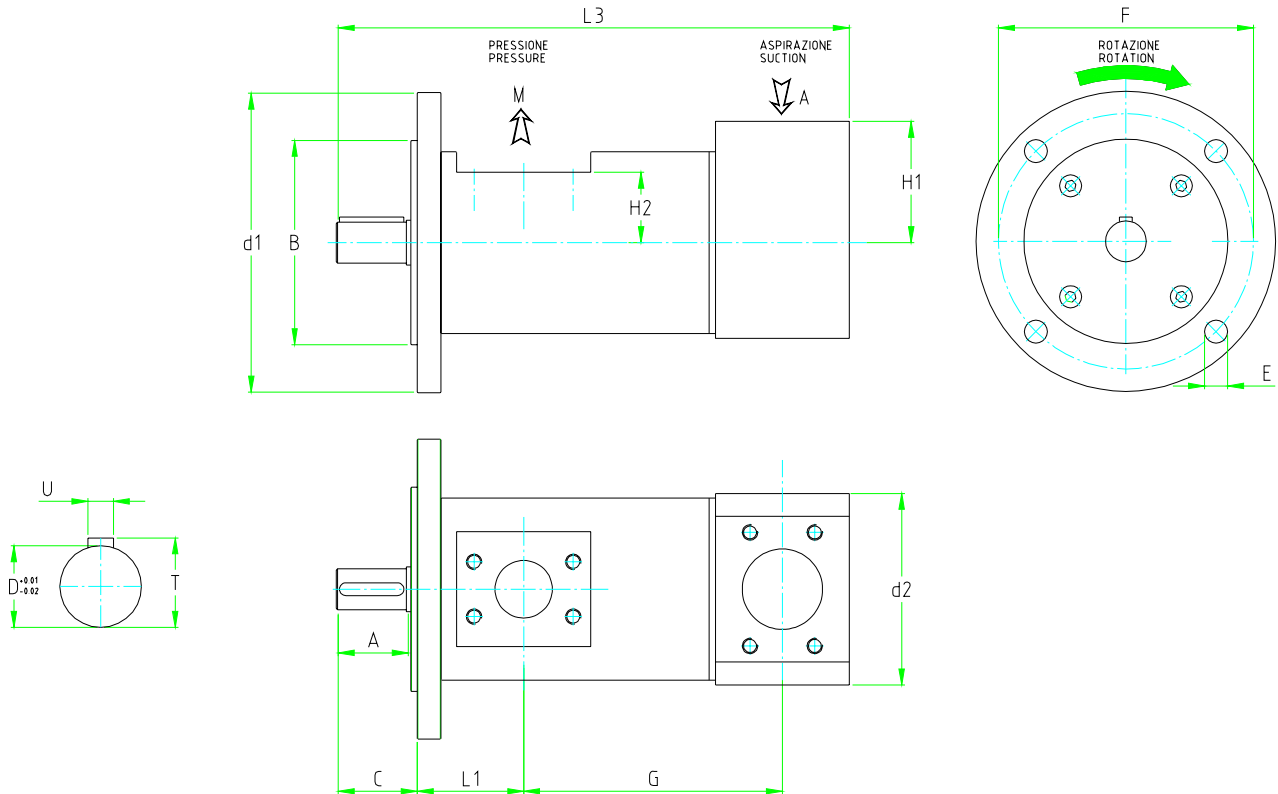

TIPO TYPE	Flange				Shaft				Suction		Discharge		Pump					
	B	E	F	d1	A	D	T	U	Ø _A	H1	Ø _M	H2	C	d2	L3	L1	G	Kg
GR 20 8-12-15-20L	80	11	103	125	31	14	16	5	1 1/2" GAS	25	3/4" GAS	25	37	59	187	55,5	76	1,5
GR25 (hollow shaft) 25-30L	70	6,5	85	105	-	14	16,2	5,2	3/4" GAS	26,7	1/2" GAS	27,3	-	65	174	70	86	2,7
GR 32 35-45-55-75L	100	11	125	150	36	19	21,5	6	1 1/4" SAE	54,5	1" SAE	41	41	95,5	259	62	122,5	4,4
GR 40 100-125-150L	125	14	160	188	36	19	21,5	6	1 1/2" SAE	65	1 1/4" SAE	46,5	46	112	304	69	150	7
GR 45 180-210L	125	14	160	188	55	32	35	10	2" SAE	83,5	1 1/2" SAE	51,5	64,5	126,5	375	75	190	11
GR 55 250-300-330-380L	160	18	200	235	55	32	35	10	2 1/2" SAE	94	2" SAE	54	64,5	148,5	398,5	83,5	202	15,5
GR 60 440-500L	160	18	200	235	55	32	35	10	3" SAE	105	2 1/2" SAE	63,5	66	160	440	83,5	228	25
GR 70 600-660-800L	200	22	250	300	55	32	35	10	3 1/2" SAE	110	3" SAE	83	67	181	506	93,5	277	30
GR 80 1000-1200L	200	22	250	300	60	38	41	10	4" SAE	125	3" SAE	83	76	212	594,5	150	295	47,5

The data shown in the catalogue can change without notice.
For special applications – please contact the main office.

SCREW PUMPS MEDIUM PRESSURE TYPE SMxT1 6B

Dry & submersible screw pumps for industrial applications - Working pressure 40 bar continuous

Dimensional drawing – series SMIT16B

Submersible screw pump

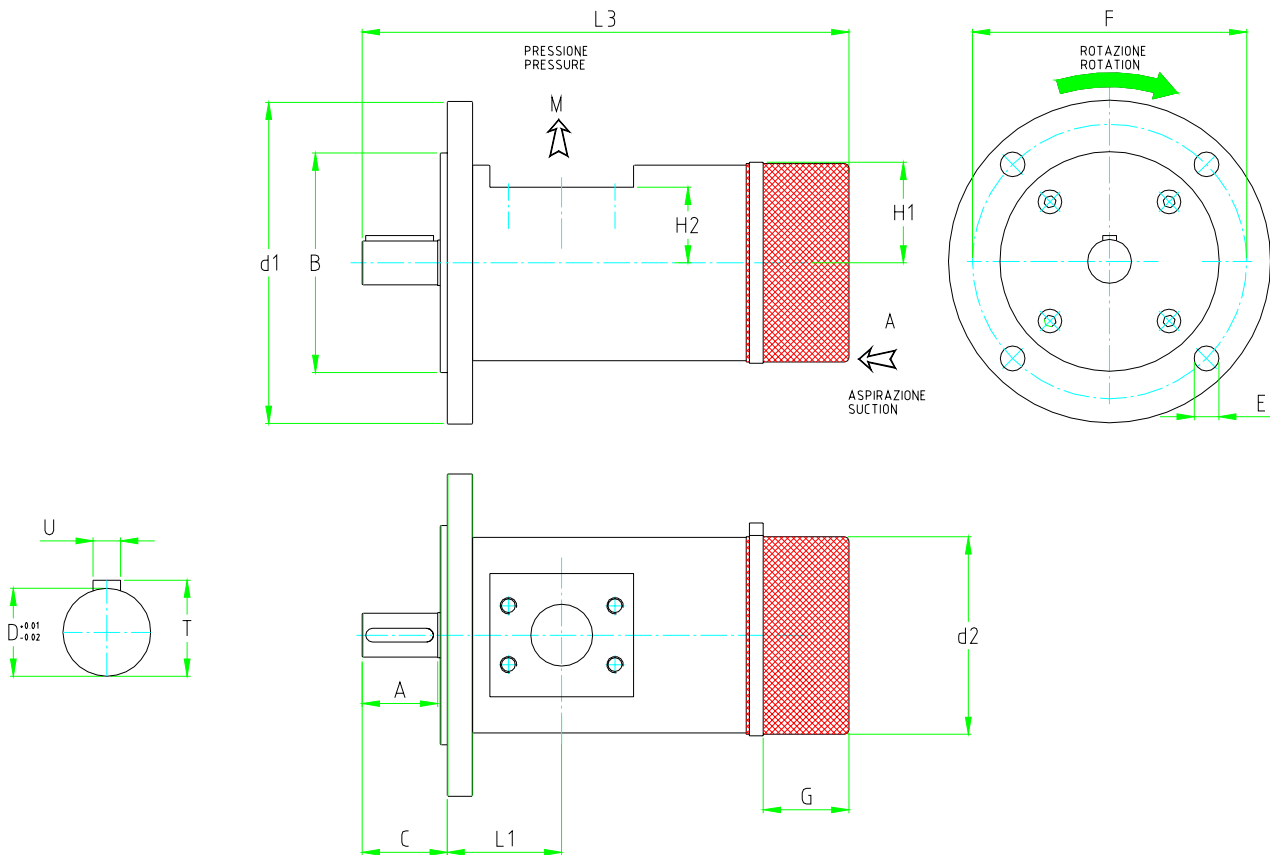

TIPO TYPE	Flange				Shaft				Discharge		Pump					
	B	E	F	$d1$	A	D	T	U	\varnothing_M	H2	C	G	$d2$	L1	L3	Kg
GR 20 8-12-15-20L	80	11	103	125	31	14	16	5	3/4" GAS	25	37	40	60	55,5	197	1,3
GR25 (hollow shaft) 25-30L	70	6,5	85	105	-	146,2	5,2		1/2" GAS	27,3	-	65	174	70	86	2,7
GR 32 35-45-55-75L	100	11	125	150	36	19	21,5	6	1" SAE	41	41	70	96	62	265	4
GR 40 100-125-150L	125	14	160	188	36	19	21,5	6	1 1/4" SAE	46,5	46	70	110	69	295	6,4
GR 45 180-210L	125	14	160	188	55	32	35	10	1 1/2" SAE	51,5	64,5	70	124	75	355	10
GR 55 250-300-330-380L	160	18	200	235	55	32	35	10	2" SAE	54	64,5	100	145	83,5	400	15
GR 60 440-500L	160	18	200	235	55	32	35	10	2 1/2" SAE	63,5	66	100	155	83,5	415	22
GR 70 600-660-800L	200	22	250	300	55	32	35	10	3" SAE	83	67	100	182	93,5	461	26
GR 80 1000-1200L	220	22	250	300	60	38	41	10	3" SAE	83	76	100	202	150	543	45

The data shown in the catalogue can change without notice.
For special applications – please contact the main office.

SCREW PUMPS MEDIUM PRESSURE TYPE SMxT1 6B

Dry & submersible screw pumps for industrial applications - Working pressure 40 bar continuous

Direct coupling motor/pump

IEC standard motor

The flanges marked in the following table are available in stock.
For other couplings, please contact Settima Meccanica.
Special applications available.

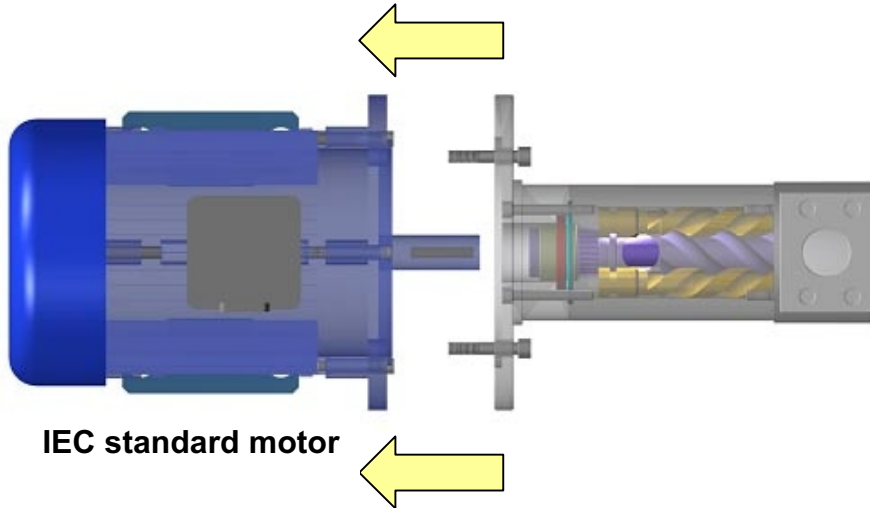

		Motor dimension								
Motor Form		56	63	71	80	90	100	112	132	160
GR20	B14									
	B5									
	B5 reduced									
GR25	B14									
	B5									
	B5 reduced									
GR32	B14									
	B5									
	B5 reduced									
GR40	B14									
	B5									
	B5 reduced									
GR45	B14									
	B5									
	B5 reduced									
GR55	B14									
	B5									
	B5 reduced									
GR60	B14									
	B5									
	B5 reduced									
GR70	B14									
	B5									
	B5 reduced									
GR80	B14									
	B5									
	B5 reduced									

Advantages:

- ✻ Save the costs for bell-housing and coupling
- ✻ Save time for mounting and maintenance
- ✻ Save the size

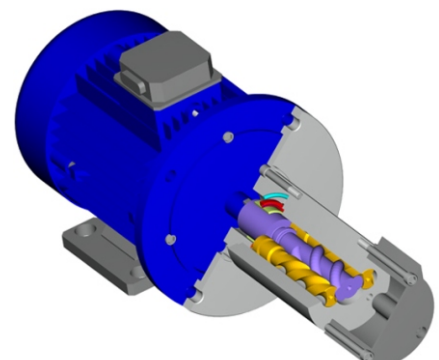

SCREW PUMPS MEDIUM PRESSURE TYPE SMxT16B

Dry & submersible screw pumps for industrial applications - Working pressure 40 bar continuous

Performances

2 poles motor – 50Hz

Pump types SMT16B/SMIT16B – maximum operating pressure 40 bar
Flow / Pressure / Power tables

Type		6 cSt					68 cSt					400 cSt (*)					
		Operating pressure (bar)					Operating pressure (bar)					Operating pressure (bar)					
		5	10	20	30	40	5	10	20	30	40	5	10	20	30	40	
GR 20	8 L	l/min	8,3	8	7,2	-	-	9	8,8	8,6	8,3	8	9,6	9,3	9	8,6	8,3
		KW	0,2	0,2	0,3	-	-	0,2	0,2	0,4	0,6	0,7	0,2	0,3	0,5	0,7	0,9
	12 L	l/min	12,4	12,0	10,6	-	-	14,3	13,5	13,1	12,7	12,3	14,6	14,2	13,8	13,2	12,6
		KW	0,3	0,3	0,5	-	-	0,2	0,3	0,6	0,8	1,1	0,3	0,4	0,7	1	1,3
	15 L	l/min	16,0	15,6	14,0	-	-	18,5	17,5	17,0	16,5	16,0	18,6	18,3	18,0	17,4	17,0
		KW	0,4	0,4	0,6	-	-	0,3	0,4	0,6	1,1	1,4	0,3	0,5	0,9	1,4	1,8
23 L	l/min	23,0	22,7	21,0	-	-	26,3	25,2	24,6	24,0	23,5	26,6	26,3	26,0	25,2	24,8	
	KW	0,5	0,5	0,9	-	-	0,4	0,6	0,9	1,6	2	0,4	0,7	1,3	2	2,5	
GR25	25 L	l/min	27,7	26,8	23,7	-	-	31,9	30,1	29,2	28,3	27,5	32,6	31,7	30,8	29,5	28,1
	KW	0,7	0,7	1,1	-	-	0,4	0,7	1,3	1,8	2,5	0,7	0,9	1,6	2,2	2,9	
30L	l/min	34,6	33,5	29,6	-	-	39,9	37,7	36,6	35,4	34,3	40,7	39,6	38,5	36,8	35,2	
	KW	0,8	0,8	1,4	-	-	0,6	0,8	1,7	2,2	3,1	0,8	1,1	2,0	2,8	3,6	
GR32	35 L	l/min	35,8	35,0	32,6	-	-	40,3	39,0	38,4	37,8	37,2	41,0	40,6	40,0	39,0	38,7
		KW	0,8	0,8	1,3	-	-	0,7	1,0	1,6	2,5	3,3	0,6	1	2	3	3,9
	45 L	l/min	45,2	44,0	40,6	-	-	49,3	48,8	48,4	48,0	47,5	51,3	50,8	50,3	49,2	48,8
		KW	0,8	1,0	1,6	-	-	0,8	1,2	2,2	3,2	4,0	0,7	1,3	2,5	3,8	4,8
	55 L	l/min	55,8	54,6	50,4	-	-	59,0	58,0	57,0	56,0	55,0	60,0	59,4	58,7	57,7	57,3
		KW	0,9	1,1	2	-	-	1,0	1,4	2,5	3,7	4,7	0,8	1,5	2,9	4,4	5,8
75 L	l/min	76,0	74,7	69,0	-	-	82,0	80,3	79,6	78,0	75,8	82,0	81,4	80,6	79,2	78,5	
	KW	1,0	1,6	2,8	-	-	1,2	1,8	3,3	4,7	6,0	1,2	2,1	4,1	6,0	8,0	
GR 40	100 L	l/min	98,4	97,0	90,5	-	-	106,0	104,0	100,0	96,0	92,8	107,0	106,0	105,0	103,0	102,4
		KW	1,2	2,0	3,6	-	-	1,5	2,5	4,5	6,5	8,4	1,5	2,7	5,3	7,8	10,0
	125 L	l/min	123,0	121,0	111,0	-	-	130,0	128,0	126,0	124,0	122,0	133,0	132,0	130,0	128,0	127,0
		KW	1,4	2,5	4,6	-	-	1,8	3,0	5,4	7,9	10,4	1,9	3,3	6,5	9,6	12,5
150 L	l/min	145,0	143,0	135,0	-	-	153,0	151,0	149,0	147,0	144,5	155,6	155,0	153,0	151,0	149,0	
	KW	1,6	3,0	5,6	-	-	2,0	3,5	6,5	9,5	12,8	2,2	3,9	7,7	11,4	15,0	
GR45	180 L	l/min	174,2	172,0	161,0	-	-	185,0	183,0	180,0	177,0	174,0	188,0	187,0	185,0	182,0	180,0
		KW	1,9	3,7	6,7	-	-	2,5	4,0	7,8	11,2	14,9	2,6	4,7	9,3	13,8	18,0
	210 L	l/min	205	203,0	192,0	-	-	216,0	214,0	211,5	208,0	204,5	219,0	218,0	217,0	214,0	212,0
		KW	2,4	4,2	8,0	-	-	3,0	5,0	9,0	13,4	17,3	3,0	5,5	10,9	16,2	21,0
GR55	250 L	l/min	262,0	260,0	246,0	-	-	278,0	276,0	271,0	266,0	263,0	281,0	280,0	278,0	274,0	273,0
		KW	3,0	5,5	10,0	-	-	3,5	6,0	11,5	17,0	23,0	4,0	7,0	13,9	20,6	27,0
	300 L	l/min	293,8	291,0	276,0	-	-	308,0	305,0	301,0	297,0	293,0	311,6	310,0	308,0	304,0	302,0
		KW	3,6	6,2	11,0	-	-	4,0	6,9	12,5	18,8	24,0	4,6	7,8	15,4	23,0	30,0
	330 L	l/min	334,0	330,0	315,0	-	-	352,0	346,0	340,0	334,0	330,0	354,0	352,0	349,0	343,0	341,0
		KW	4,0	7,4	13,0	-	-	4,4	7,6	14,5	21,5	28,5	5,0	8,8	17,5	26,0	34,0
380 L	l/min	373,0	370,0	356,3	-	-	389,0	386,5	382,0	378,0	374,0	396,0	394,4	391,0	387,1	383,0	
	KW	4,4	8,0	14,4	-	-	5,0	8,5	16,0	23,8	31,5	6,0	9,9	19,6	29,0	38,0	
GR 60	440 L	l/min	438,8	436,0	413,0	-	-	458,0	455,0	450,0	445,0	440,0	464,0	462,0	459,0	453,0	451,0
		KW	5,0	9,3	17,0	-	-	6,2	10,0	19,0	28,0	34,0	6,5	11,6	23,0	34,0	45,0
	500 L	l/min	503,0	500,0	484,5	-	-	519,0	516,0	511,0	506,0	501,0	526,0	524,0	520,0	515,7	512,0
		KW	6,2	11,0	19,0	-	-	7,5	11,0	22,0	30,0	42,0	7,4	13,2	26,0	38,0	51,0
GR 70	600 L	l/min	609,0	606,0	580,0	-	-	628,0	625,0	619,0	614,0	608,0	635,0	633,0	629,0	622,0	620,0
		KW	7,4	13,0	24,0	-	-	8,0	14,0	26,0	38,0	51,0	9,0	16,0	31,5	46,0	62,0
	660 L	l/min	663,0	660,0	636,0	-	-	684,0	681,0	676,0	671,0	665,0	691,0	689,0	685,0	676,0	674,0
		KW	8,0	14,0	26,0	-	-	9,0	15,0	28,6	42,0	55,0	10,0	17,4	34,3	51,0	68,0
	800 L	l/min	802	798,0	768,0	-	-	830,0	826,0	820,0	815,0	810,0	839,0	836,0	831,0	823,0	819,0
		KW	9,0	16,7	31,0	-	-	10,5	18,0	34,0	51,0	68,0	11,0	21,0	42,0	62,0	82,0
GR 80	1.000 L	l/min	1.000,0	996,0	972,0	-	-	1.034,0	1.030,0	1.024,0	1.017,0	1.010,0	1.043,0	1.040,0	1.035,0	1.026,0	1.023,0
		KW	11,0	20,5	40,0	-	-	12,5	22,0	43,0	64,0	85,0	15,0	26,0	52,0	76,0	103,0
	1.200 L	l/min	1.218,0	1.214,0	1.170,0	-	-	1.254,0	1.250,0	1.242,0	1.234,0	1.225,0	1.268,0	1.264,0	1.258,0	1.247,0	1.241,0
		KW	13,5	25,0	48,0	-	-	16,0	27,0	52,0	78,0	106,0	18,0	32,0	63,0	93,0	125,0

(*) For high viscosity applications and/or oil-air emulsions, please check with us the suitable pump model

The data shown in the catalogue can change without notice.
For special applications – please contact the main office.

SCREW PUMPS MEDIUM PRESSURE TYPE SMxT1 6B

Dry & submersible screw pumps for industrial applications - Working pressure 40 bar continuous

Performances

4 poles motor – 50Hz

Pump types SMT16B/SMIT16B – maximum operating pressure 40 bar
Flow / Pressure / Power tables

Type		6 cSt					68 cSt					400 cSt (*)					
		Operating pressure (bar)					Operating pressure (bar)					Operating pressure (bar)					
		5	10	20	30	40	5	10	20	30	40	5	10	20	30	40	
GR 20	8 L	l/min	3,7	3,6	3,0	-	-	4,2	4	3,9	3,7	3,5	4,5	4,4	4,3	4,2	4,1
		KW	0,2	0,2	0,2	-	-	0,2	0,2	0,2	0,3	0,4	0,2	0,2	0,3	0,4	0,5
	12 L	l/min	5,7	5,5	4,7	-	-	6,2	6,1	6,0	5,8	5,5	6,9	6,8	6,7	6,6	6,5
		KW	0,2	0,2	0,3	-	-	0,2	0,2	0,3	0,4	0,6	0,2	0,3	0,4	0,6	0,7
	15 L	l/min	7,3	7,0	5,9	-	-	8,2	8	7,8	7,4	7,0	8,9	8,8	8,7	8,5	8,2
		KW	0,2	0,2	0,3	-	-	0,2	0,2	0,4	0,6	0,8	0,2	0,3	0,5	0,7	0,9
23 L	l/min	10,8	10,4	8,9	-	-	11,8	11,5	11,2	10,8	10,3	12,8	12,7	12,5	12,2	11,8	
	KW	0,3	0,3	0,4	-	-	0,3	0,3	0,6	0,8	1,0	0,3	0,4	0,7	1,0	1,3	
GR25	25 L	l/min	12,7	12,3	10,5	-	-	13,8	13,6	13,4	12,9	12,3	15,4	15,2	15,0	14,7	14,5
	KW	0,4	0,4	0,7	-	-	0,4	0,4	0,7	0,9	1,3	0,4	0,6	0,9	1,3	1,6	
30L	l/min	15,9	15,3	13,1	-	-	17,3	17,0	16,7	16,2	15,3	19,3	19,0	18,7	18,4	18,1	
	KW	0,6	0,6	0,8	-	-	0,6	0,6	0,8	1,1	1,7	0,6	0,7	1,1	1,7	2,0	
GR32	35 L	l/min	16,3	15,9	14,0	-	-	18,4	18,0	17,4	16,7	16,0	19,9	19,7	19,5	19,1	18,8
		KW	0,3	0,4	0,7	-	-	0,3	0,4	0,8	1,2	1,4	0,4	0,6	1	1,5	2,2
	45 L	l/min	20,5	20,0	17,8	-	-	22,8	22,5	22,0	21,2	20,5	25,0	24,8	24,4	23,9	23,4
		KW	0,3	0,5	0,8	-	-	0,4	0,5	1,0	1,4	1,8	0,5	0,8	1,3	1,9	2,4
	55 L	l/min	25,4	24,8	22,0	-	-	28,0	27,6	26,8	26,0	25,0	29,8	29,0	28,7	28,2	27,6
		KW	0,4	0,6	1,0	-	-	0,5	0,6	1,2	1,8	2,2	0,6	1,0	1,5	2,2	2,8
75 L	l/min	34,5	34,0	31,0	-	-	39,0	38,5	37,0	36,0	35,0	40,8	40,0	39,4	38,8	38,0	
	KW	0,4	0,7	1,4	-	-	0,6	0,8	1,6	2,3	2,9	0,7	1,2	2	3,0	3,9	
GR 40	100 L	l/min	48,1	44,5	39,0	-	-	50,2	49,8	48,0	46,7	45,2	52,7	52,0	51,3	50,2	49,0
		KW	0,6	1,0	1,7	-	-	0,8	1,0	2,0	3,0	3,8	0,8	1,4	2,6	3,8	5,0
	125 L	l/min	56,4	55,5	48,8	-	-	61,4	61,0	59,0	57,2	55,8	65,6	65,0	64,0	63,0	61,8
		KW	0,8	1,2	2,0	-	-	0,9	1,2	2,4	3,6	4,8	1	1,7	3,3	4,8	6,3
150 L	l/min	67,0	66,2	58,4	-	-	73,4	72,9	71,0	68,6	67,0	77,0	76,2	75,2	74,0	72,7	
	KW	0,9	1,4	2,5	-	-	1,0	1,5	3	4,5	5,7	1,2	2	3,8	5,6	7,4	
GR45	180 L	l/min	81,5	80,4	74,0	-	-	88,6	88,0	85,7	83,4	81,2	92,9	92,0	90,8	89,3	87,9
		KW	1,2	1,8	3,4	-	-	1,5	1,8	3,5	5,4	6,7	1,5	2,4	4,6	6,8	8,9
	210 L	l/min	96,2	95,2	86,0	-	-	103,0	102,0	99,0	96,2	94,3	108,0	107,2	105,6	103,8	101,9
		KW	1,4	2	3,8	-	-	1,6	2,2	4,0	6,0	7,8	1,6	2,7	5,4	7,9	10,4
GR55	250 L	l/min	126,6	125,5	115,0	-	-	135,0	134,0	131,6	129,0	126,2	139,0	138,5	137,3	135,9	134,0
		KW	1,6	2,7	5,0	-	-	2,0	3,0	5,3	8,0	10,5	1,9	3,5	6,9	10,5	13,5
	300 L	l/min	141,0	140,0	128,4	-	-	150,0	149,0	146,6	143,5	140,0	154,0	153,2	152,0	150,4	148,0
		KW	1,8	3,0	5,5	-	-	2,2	3,5	6,0	9,0	11,6	2,2	4	7,7	11,4	15
	330 L	l/min	160,0	158,7	146,0	-	-	170,0	168,8	166,0	162,5	160,5	175,0	174,0	172,2	170,0	168,0
		KW	2,0	3,5	6,0	-	-	2,5	4,0	6,8	10	13	2,5	4,4	8,7	13	17
380 L	l/min	179,0	176,7	161,0	-	-	189,5	188,0	185,0	182,0	179,0	196,0	195,0	192,8	190,5	188,0	
	KW	2,6	4,0	7,0	-	-	3,0	4,5	7,6	11	14,6	2,6	5	9,7	14,6	19	
GR 60	440 L	l/min	208,0	206,0	198,0	-	-	221,0	219,0	217,0	214,0	211,0	229,5	228,5	226,0	223,0	220,0
		KW	2,8	4,5	8,2	-	-	3,2	5,0	9,0	13,0	17,4	3,0	5,9	11,5	17,0	22,0
	500 L	l/min	239,0	236,0	227,0	-	-	252,0	250,0	247,0	244,0	241,0	260,0	259,0	256,0	253,0	250,0
		KW	3,2	5,0	10,0	-	-	3,3	5,5	10,0	15,0	20,0	3,5	6,6	13,0	19,0	25,0
GR 70	600 L	l/min	290,0	287,0	275,0	-	-	306,0	304,0	300,0	297,0	294,0	315,0	313,0	310,0	306,0	303,0
		KW	3,6	6,0	11,0	-	-	4,0	6,5	12,5	18,0	24,0	4,3	8,0	15,8	23,0	30,0
	660 L	l/min	316,0	314,0	301,0	-	-	335,0	332,0	328,0	325,0	321,0	343,0	341,0	337,0	332,5	328,0
		KW	4,0	6,8	12,0	-	-	4,5	7,0	13,5	20,0	26,0	4,7	8,7	17,0	25	33,0
	800 L	l/min	381,0	378,0	365,0	-	-	406,0	403,0	399,0	396,0	390,5	415,0	413,0	409,6	405	401,0
		KW	4,5	8,0	15,0	-	-	5,5	9,0	16,0	24,0	31	5,8	10,5	20,5	31	40,0
GR 80	1.000 L	l/min	483,0	480,0	462,0	-	-	509,0	506,0	501,0	496,0	490,2	516,0	514,0	511,0	507	502,0
		KW	6,0	10,0	19,0	-	-	6,0	10,0	21,0	30,0	40	7,0	13,0	26	38	50,0
	1.200 L	l/min	586,0	582,0	562,0	-	-	615,0	612,0	606,0	600,0	594,0	627,0	625,0	621,0	615	610,0
		KW	7,0	12,0	23,0	-	-	7,5	13,0	25,0	36,0	48	9,0	16,0	31	46,0	61,0

(*) For high viscosity applications and/or oil-air emulsions, please check with us the suitable pump model

The data shown in the catalogue can change without notice.
For special applications – please contact the main office.

SCREW PUMPS MEDIUM PRESSURE TYPE SMxT1 6B

Dry & submersible screw pumps for industrial applications - Working pressure 40 bar continuous

Ordering code

GR **	****	***L	*	****/***	*	*	***	***
1	2	3	4	5/6	7	8	9	10
Pump Type	Dry or submersible	Nominal Flow (L/min 2750 rpm)	High viscosity flag ⁽¹⁾	Hollow shaft type / Flange type (Omit for normal shaft)	Pump body	Shaft Seal	Internal pressure relief valve ⁽²⁾	Rotation
GR20		8						
		12						
GR25		15						
		23						
GR32		25	None	Up to 100 cSt	Motor shaft (5)		None	No security valve
		30						
GR40	SMT16B dry	35	S1	from 100 to 250 cSt	AC11	None	NBR	RF1
		45						
GR45	SMIT16B submersible	55	S2	from 250 to 500 cSt	AC14	G	V	RF2
		75						
GR55		100	S3	from 500 to 800 cSt	AC19	A	EDPM	RF3
		125						
GR60		150	S4	past 800 cSt	AC24			RP ⁽²⁾
		180						
GR70		210			AC28			Variable regulation valve
		250						
GR80		300			B5			
		330						
		380			B14			
		440						
		500			B5R			
		600						
		660						
		800						
		1.000						
		1.200						

- (1) this option reduce the efficiency of the pump
 (2) RP valve available only for GR32, GR40 and GR55 models
 (3) REV available only for GR32 and GR40 models

Example:

1) GR55 SMT16B 250L S2 AC28/B5 G V RF1

Pump providing a nominal flow of 250L, for thick oil (operation viscosity between 250 and 500 cSt), hollow shaft diameter 28 (motor 132) flange B5, cast iron body, Viton seals, pressure relief valve at 5bar – DO NOT NEED bell-housing and coupling, mountable directly on the motor

2) GR80 SMT16B 1.000L

Pump providing a nominal flow of 1.000 L/min at 2.750 rpm, normal shaft, aluminium body – need bell housing and coupling

The data shown in the catalogue can change without notice.
 For special applications – please contact the main office.