

## R325P Single Axis Driver

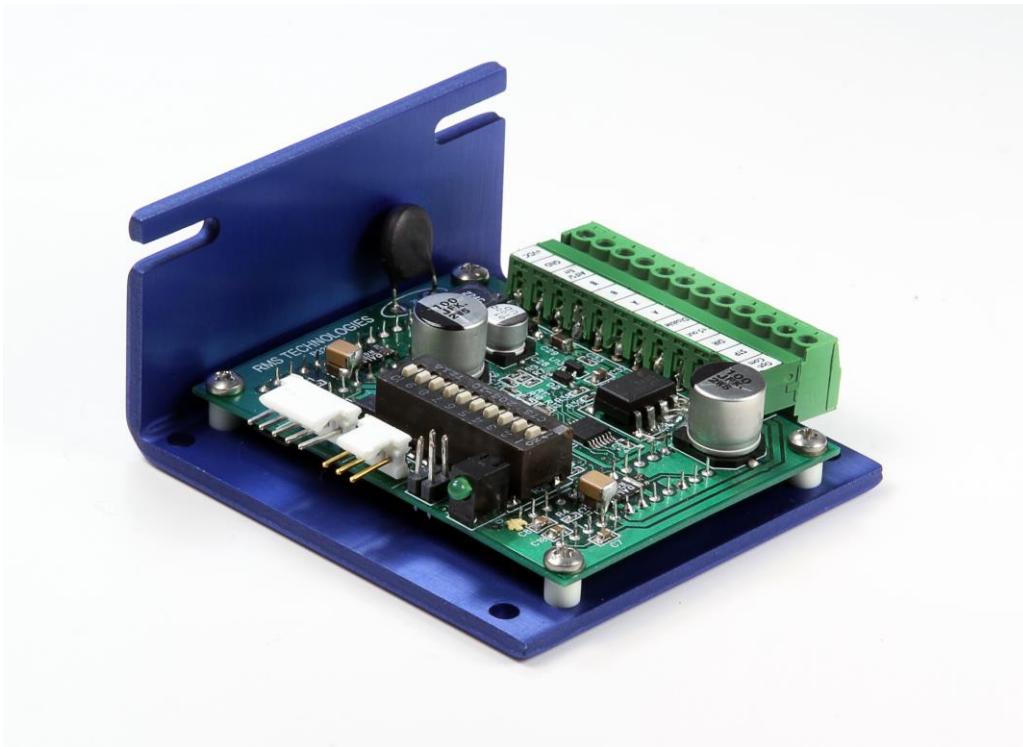

**User Manual**  
**And Commands Guide**  
Version 1.3

---

Thank you for purchasing the R325P Single-Axis Step & Direction Driver. This product is warranted to be free of manufacturing defects for one (1) year from the date of purchase.

### **PLEASE READ BEFORE USING**

Before you start, you must have a suitable step motor, a DC power supply suitable for the motor and a current resistor. The power supply voltage must be between 4 times and 20 times the motor's rated voltage.

### **DISCLAIMER**

The information provided in this document is believed to be reliable. However, no responsibility is assumed for any possible inaccuracies or omissions. Specifications are subject to change without notice.

Lin Engineering reserves the right to make changes without further notice to any products herein to improve reliability, function, or design. Lin Engineering does not assume any liability arising out of the application or use of any product or circuit described herein; neither does it convey any license under its patent rights, nor the rights of others.

### **Special Symbols**



Indicates a **WARNING** and that this information could prevent injury, loss of property, or even death (in extreme cases).

## R325P User Manual

Product: R325P

Version: 1.3

Date: 3/22/2018

Version History		
Version	Date	Description of Changes
1.00	01/31/2013	New User Manual
1.01	05/29/2013	Updated enable/disable pin description on page 8.
1.3	3/22/2018	Update name and logo

# Table of Contents

<b>1. FEATURES .....</b>	<b>5</b>
<b>2. ELECTRICAL SPECIFICATIONS .....</b>	<b>5</b>
<b>3. OPERATING SPECIFICATIONS .....</b>	<b>6</b>
<b>4. MECHANICAL SPECIFICATIONS .....</b>	<b>6</b>
<b>6. CONNECTION SPECIFICATIONS .....</b>	<b>8</b>
Connecting the Power .....	9
Connecting the Motor .....	9
Configure the R325 using the DIP Switch .....	10
DIP Switch Run Current Settings .....	10
DIP Switch Hold Current Settings .....	11
DIP Switch Step Resolution Settings .....	11
<b>8. COMMAND TABLES .....</b>	<b>11</b>
Axis Configuration Commands .....	11
General Operation Commands .....	11
<b>9. COMMANDS .....</b>	<b>13</b>
Protocol Syntax .....	13
<b>10. Troubleshooting.....</b>	<b>14</b>
<b>11. Appendix A .....</b>	<b>15</b>
<b>11. Appendix B .....</b>	<b>19</b>

## 1. FEATURES

- Single Axis Driver for Bipolar step motors
- Operates from +12 to 48 VDC
  - Phase currents from 0.3 to 3.0 Amp Peak



**NOTE: Phase current of 2.7 Amp and above REQUIRES an additional heatsink, make sure the temperature of the bracket does not exceed 45° C.**

- Hold current reduction capability with adjustable current and timeout settings
- Selectable Step Resolution from Full Step to 256x Microstepping
- Has three optically isolated control inputs and one optically isolated control output
- Pole Damping Technology™ integrated within driver board

Dip switches and a RS485 interface are built-in to the R325P Controller. A USB connection can be used by using the USB485 Converter Card (sold separately).

## 2. ELECTRICAL SPECIFICATIONS

Supply Voltage: +12 to 48 VDC  
Phase Current: 0.3 to 3.0 Amps Peak



**NOTE: Phase current of 2.7 Amp and above REQUIRES an additional heatsink, make sure the temperature of the bracket does not exceed 45° C.**

I/O Specifications

3x Optically Isolated Inputs (1 fixed)  
1x Optically Isolated Output

Minimum Motor Impedance: 1.5 mH

Note: The drive may behave unpredictably if the motor you are using has an inductance less than 1.5 mH.

### 3. OPERATING SPECIFICATIONS

Maximum Step Frequency: 2.5 MHz  
Operating Temperature: Low end – 0° C  
High end – Dependent on case temperature, bracket temperature must not exceed 45° C

Automatic Motor Holding Current reduction available from 0.3 to 2.5 Amps

#### Logic Timing

Minimum Step Pulse Width 200 nanoseconds  
Minimum Step Low Time 200 nanoseconds  
Maximum Power-Down Recovery Time 20 milliseconds

### 4. MECHANICAL SPECIFICATIONS

Size: 3.00" x 2.75" x 1.42"

Weight: 3.2 oz

Mounting: Four #6-32 screws, 2.42" x 2.45"

Plate: Aluminum, Hard Anodized

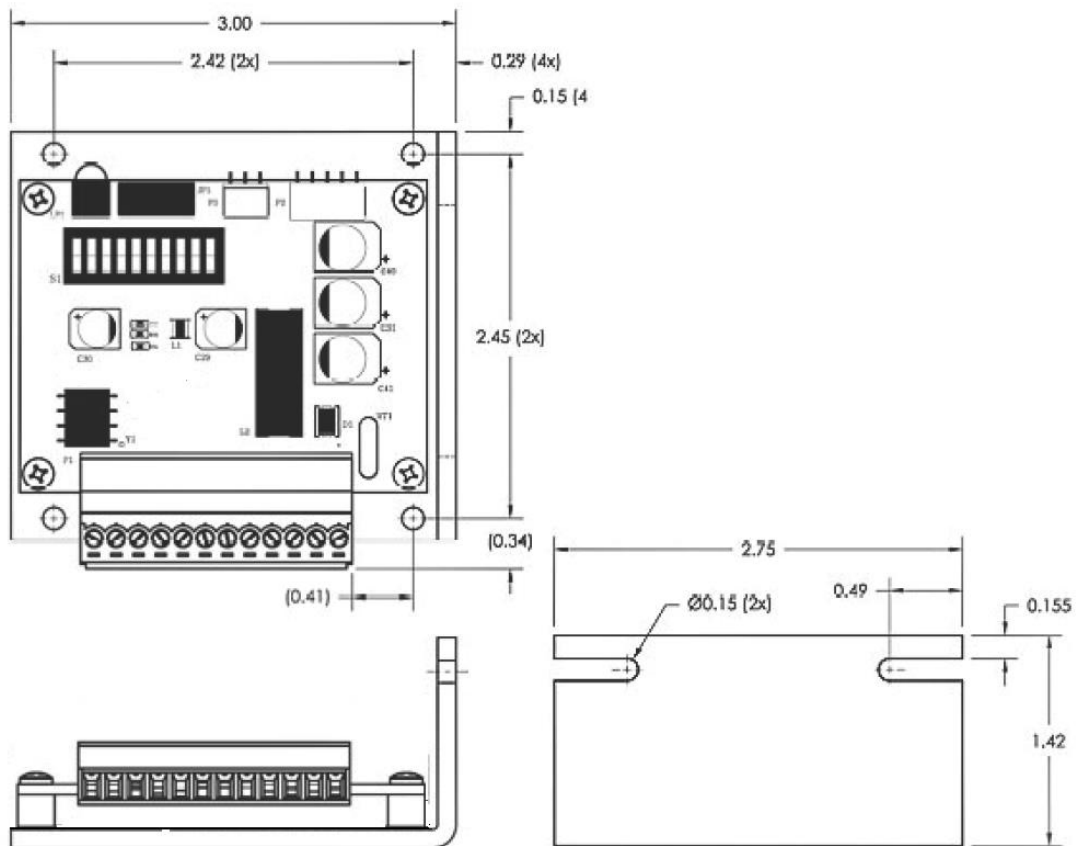

Figure 3.1

## 5. PIN ASSIGNMENTS

### Mating Connectors

P1 Amp 640441-3

P3 Phoenix Contact 1803675

### P1 – RS485 bus Interface

P1 Configuration	
Pin No	Function
1	A Input (+ve)
2	Ground
3	B Input (-ve)

Table 5.1

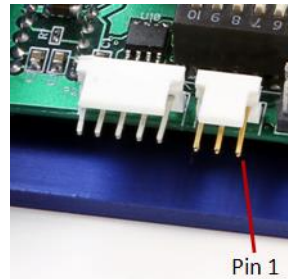

P1 Connector – Pin 1 Location

Image 5.1

### P3 – Motor/Controls/Power Interface

A 12-pin pluggable terminal strip connector P3 provides power and the step and direction control functions for the module. All of these signals are optically isolated. Open-collector drives are required to provide pulses for Step, levels for Direction, and Disable. The common +ve supply ranges from 5 VDC to 30 VDC with respect to the signal input; however if the supply is greater than 5 VDC then a resistor must be inserted in series with each signal line to limit the current to 10 mA.

P3 Configuration	
Pin No	Function
1	Common +ve External
2	Step (in)
3	Direction (in)
4	+5 VDC Internal
5	Disable (in)
6	Motor A+ (out)
7	Motor A- (out)
8	Motor B+ (out)
9	Motor B- (out)
10	Full Step Output
11	Power Ground
12	Power Positive

Table 5.2



P3 Connector – Pin 1 Location

Image 5.2



**CAUTION:** Connecting Motor phases (A, A Bar, B, B Bar) to the incorrect location while the R325P is powered will cause the board to burn. Be sure to insert motor phases into Pins 6 through 9, in the order of A, A Bar, B, and B Bar. It is recommended that power is connected last, so that all connections can be checked before power up.

## **6. CONNECTION SPECIFICATIONS**

When using the Driver Only portion of the R325P, use the dip switches for step resolution and current settings.

### **Using the R325P as a Driver Unit Only**

If using the R325P as a Driver only, **be sure to connect the power supply last.**

**Pin 1:** Connect Pin 1 to Pin 4 to use the internal +5VDC. By using the internal +5VDC the I/O's will no longer be optically isolated. If optical isolation is still desired, use a separate +5VDC supply and connect the POSITIVE end of the supply to Pin 1. The NEGATIVE end will connect with the NEGATIVE end of your pulse generator.

**Pin 2:** Use a pulse generator or function generator to receive pulses into the R325P. Connect the POSITIVE end of the pulse generator to Pin 2. The NEGATIVE end will be connected to the NEGATIVE end of the +5VDC supply if using a separate power source. If using the internal +5VDC supply, connect the NEGATIVE end of the pulse generator to Power GROUND.

**Pin 3:** To switch the direction of motor rotation, connect Pin 3 with Pin 11, Power Ground. An open or closed connection to Power Ground will change the direction.

**Pin 4:** This is the internal +5VDC. Use this for testing purposes or if optical isolation of the inputs is not desired, connect to pin 1. It can output a max of 50 mAmps.

**Pin 5:** To enable the drive leave this Pin open, disable the drive connect Pin 5 with Pin 11 (Power Ground). An open or closed connection to Power Ground will enable and disable the drive, respectively. A closed connection will remove all power to the output motor leads (Pins 6 through 9).

**Pin 6:** Phase A Motor Connection

**Pin 7:** Phase  $\bar{A}$  Motor Connection

**Pin 8:** Phase B Motor Connection

**Pin 9:** Phase  $\bar{B}$  Motor Connection



**CAUTION:** Connecting Motor phases (A, A Bar, B, B Bar) to the incorrect location while the R325P is powered will cause the board to burn. Be sure to insert motor phases into Pins 6 through 9, in the order of A, A Bar, B, and B Bar. It is recommended that power is connected last, so that all connections can be checked before power up.

**Pin 10:** The Full Step output is not available for the basic R325P. This feature is used on the R325PE.

**Pin 11:** Connect the NEGATIVE of the Power Supply to this terminal.

**Pin 12:** Connect the POSITIVE of the Power Supply to this terminal. (+12 to 48VDC)



## Connecting the Power

The R325P requires a supply voltage between 12-48 VDC. First, connect the positive end of the power supply to positive terminal (Pin 12), and then connect the negative of the power supply to the Ground (Pin 11) on the R325P.



**WARNING!** Be careful not to reverse the polarity from the power supply to the driver. Reversing the connection will destroy your driver and void the warranty.

## Connecting the Motor



**WARNING!** Make sure the power is OFF when connecting or disconnecting motors from the R325P. Damage will occur if the power is being supplied.

Please refer to your motor documentation for wiring color code.

Connect the corresponding Phase from the motor to the proper pin on the R325P.

<b>Motor Phase</b>	<b>P1 Connector</b>
Phase A	Pin 6
Phase A-	Pin 7
Phase B	Pin 8
Phase B-	Pin 9

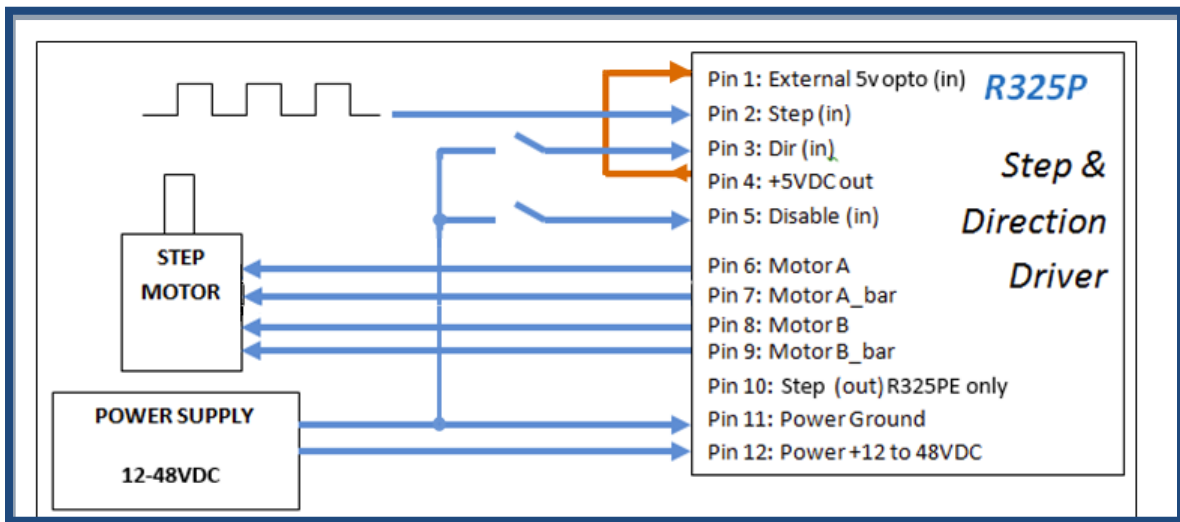

Figure 6.1

## Using the R325P with more than 5V

You can choose to supply the optos with the R325P's internal 5V supply by jumping pins 1 to 4. But if you choose to use more than 5V, for example, a 24V supply and the step pulse train is also a 0 to 24V low-high signal, please use the following recommended resistor to limit the current to 10 mAmps. Note: no resistor will be needed on the actual opto supply line, pin 1.

### Step & Direction lines have a 470 ohm internal resistor

Voltage:	5V	10V	15V	24V
Ohms needed:	0	500	1000	2000
Wattage rating:	0	¼ watt	¼ watt	¼ watt

*Table 6.1*

### Disable line has a 1k ohm internal resistor

Voltage:	5V	10V	15V	24V
Ohms needed:	0	1000	2000	3800
Wattage rating:	0	1/8 watt	1/8 watt	¼ watt

*Table 6.2*

## Configure the R325P using the DIP Switch

### R325P DIP Switch Settings

Function	Run Current			
	SW1	SW2	SW3	SW4
0.3A	ON	ON	ON	ON
0.4A	OFF	ON	ON	ON
0.5A	ON	OFF	ON	ON
0.6A	OFF	OFF	ON	ON
0.8A	ON	ON	OFF	ON
1.0A	OFF	ON	OFF	ON
1.2A	ON	OFF	OFF	ON
1.4A	OFF	OFF	OFF	ON
1.6A	ON	ON	ON	OFF
1.8A	OFF	ON	ON	OFF
2.0A	ON	OFF	ON	OFF
2.2A	OFF	OFF	ON	OFF
2.4A	ON	ON	OFF	OFF
2.6A	OFF	ON	OFF	OFF
2.8A	ON	OFF	OFF	OFF
3.0A	OFF	OFF	OFF	OFF

*Table 6.3*



**WARNING: Current of 2.7 Amp and above REQUIRES an additional heat sink; make sure the temperature of the bracket does not exceed 45° C**

Hold Current (Percent of Run Current)		
Function	SW5	SW6
0%	ON	ON
33%	OFF	ON
66%	ON	OFF
100%	OFF	OFF

Table 6.4

Step Resolution				
Function	SW7	SW8	SW9	SW10
Full Step*	OFF	OFF	OFF	OFF
2X	ON	OFF	OFF	OFF
4X	ON	ON	OFF	OFF
8X	ON	OFF	ON	OFF
16X	ON	ON	ON	OFF
32X	ON	OFF	OFF	ON
64X	ON	ON	OFF	ON
128X	ON	OFF	ON	ON
256X	ON	ON	ON	ON

Table 6.5

\*The power must be turned OFF when switching in and out of Full Step mode.

## **7. COMMAND TABLES**

### **Axis Configuration Commands**

Function	Query/New	Code	Value	Minimum	Maximum	Default
Hold Timeout	Q/N	HT	Numeric	100	5000	500
Percent Fast Decay	Q/N	PF	Numeric	0	3	2

Table 7.1

### **General Operation Commands**

Function	Query/New	Code	Value	Minimum	Maximum	Default
Firmware Rev.	Q	FR	Numeric	-	-	-

Table 7.2

## Communicating with the R325P

1. Connect P1 to PC via RS485-232 Converter Card or USB485 Converter Card.
2. Set up HyperTerminal by selecting correct COM port
3. Settings for HyperTerminal is as follows: 57600, 8 bits, None, 1, None
4. The R325P Driver only version allows for changing the hold timeout settings, the amount of mixed decay, and to check the firmware revision level.

### RS485-232 Converter Card

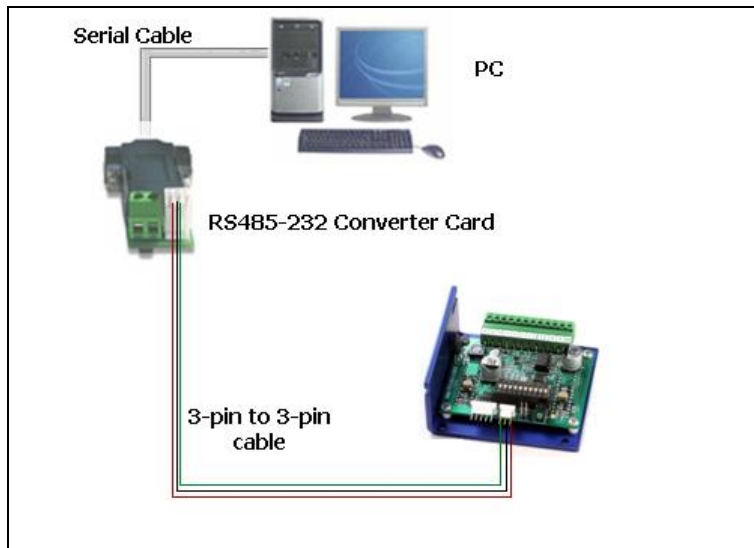

Image 7.1

### USB485 Converter Card

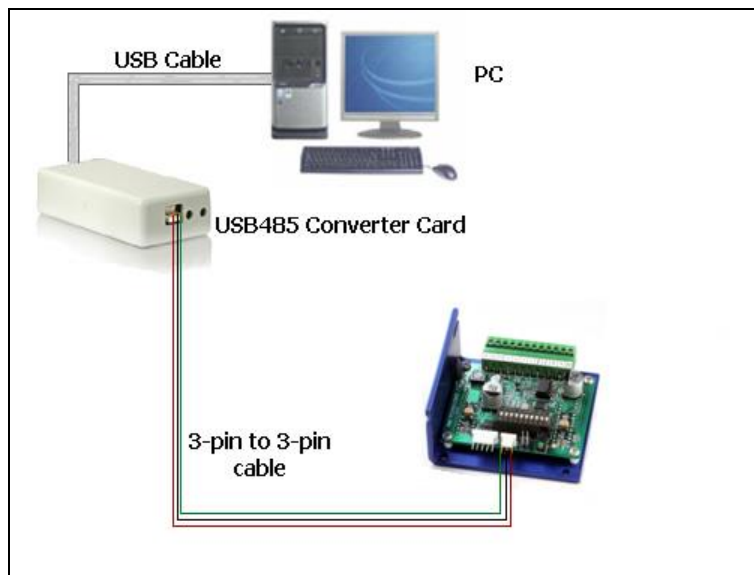

Image 7.2

## 8. COMMANDS

### Protocol Syntax

**Command Format:** #<Address><Command><value><CR><LF>  
 Example: #AHT1000<CR><LF>  
 Sets the Hold Timeout for Driver A to 1000

To query a command use the following format

**Query Format:** #<Address><Command><CR><LF>  
 Example: #AFR<CR><LF>  
 Queries Driver A for the current Firmware Revision

The response would be in the following format

**Response Format:** \*<Address><value>  
 Example: \*AFR325100  
 R325P firmware revision 1.00

<CR><LF> stand for "Carriage Return" and "Line Feed" respectively. These are NOT characters to be typed in. For direct keyboard users, these values are executed when the "Return" key is pressed. For programmers, a "Carriage Return" and "Line Feed" (also known as a "New Line") command needs to be executed after each command.

Command (Case Sensitive)	Operand	Example	Description
HT	100 -5000	#AHT100  <i>Sets the Hold Timeout to 100 mS</i>	<b>Hold Timeout</b> - Command or Query, Default = 500 - Reads or sets the time interval in milliseconds after any motor movement, before the motor current is changed from Run Current to Hold Current.
PF	0 - 3	#APF1  <i>Sets Mixed Mode damping to 48%</i>	<b>Percent Fast Decay</b> - Command or Query, Default = 2 - Allows the Damping Mode of the driver IC to be set. 0 = Slow Decay 1 = Mixed Mode 15% 2 = Mixed Mode 48% 3 = 100% Fast Decay The optimum setting will vary with motor inductance and step rate; however the default Mixed Mode setting will work with most motors
FR	-	#AFR	<b>Firmware Revision</b> - Query Only - Returns 3 digit part code followed by 3 digit firmware revision. Reply: *AFR325100 //R325P firmware revision 1.00
SD	-	#ASD	<b>Save Data</b> – After all desired changes have been made, type #ASD in order to save the data to memory.
LD	-	#ALD	<b>Load Default Settings</b> – Used to revert back to default settings.
TI	-	#ATI	<b>Test Inputs</b> – Query Only - This command will return a value which corresponds to the ON/OFF sequence of all 3 inputs

## **9. Troubleshooting**

### **R325P is not functioning correctly**

Try putting the R325P into TEST mode by placing a jumper on Pins 3 & 4 of J1 as shown below. The motor should twitch back and forth slightly if the R325P is functioning properly.

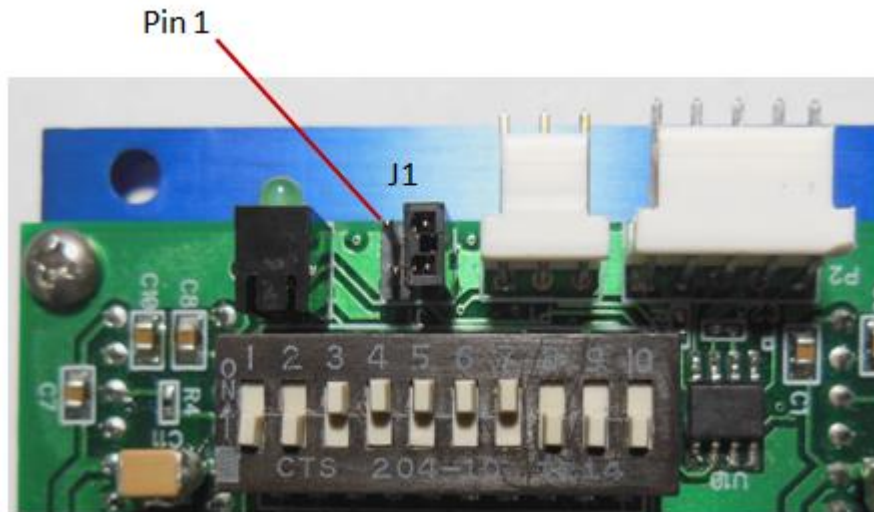

### **R325P not moving the motor (Step/Dip)**

Verify that the 5V is being supplied to Pin 1.

### **The R325P is causing the motor to vibrate and jitter back and forth**

Are the Motor phases switched? Be sure to check that motor wires are connected to Pins 6 through 9, in the order of A, A Bar, B, B Bar. To check which wires belong to one phase, take a Meter to measure resistance between any two wires. If there is a finite value between two of them, insert the wires into pins 6 and 7, OR pins 8 and 9. Insert the remaining two wires accordingly.

### **Technical Support**

**By Telephone: 408-919-0200**

**(Monday-Friday; 8:00 AM - 5:00PM Pacific)**

**On the Web: [www.linengineering.com](http://www.linengineering.com)**

Our technical support group is glad to work with you in answering your questions. If you cannot find the solution to your particular application, or, if for any reason you need additional technical assistance, please call technical support at **408-919-0200**.

## 10. Appendix A: Recommended Cable

### Recommended Cable Configurations: DC Supply to Driver

Cable length, wire gauge and power conditioning devices play a major role in the performance of your R325P Driver and stepper Motor.

NOTE: The length of the DC power supply cable to the Driver should not exceed 50 feet.

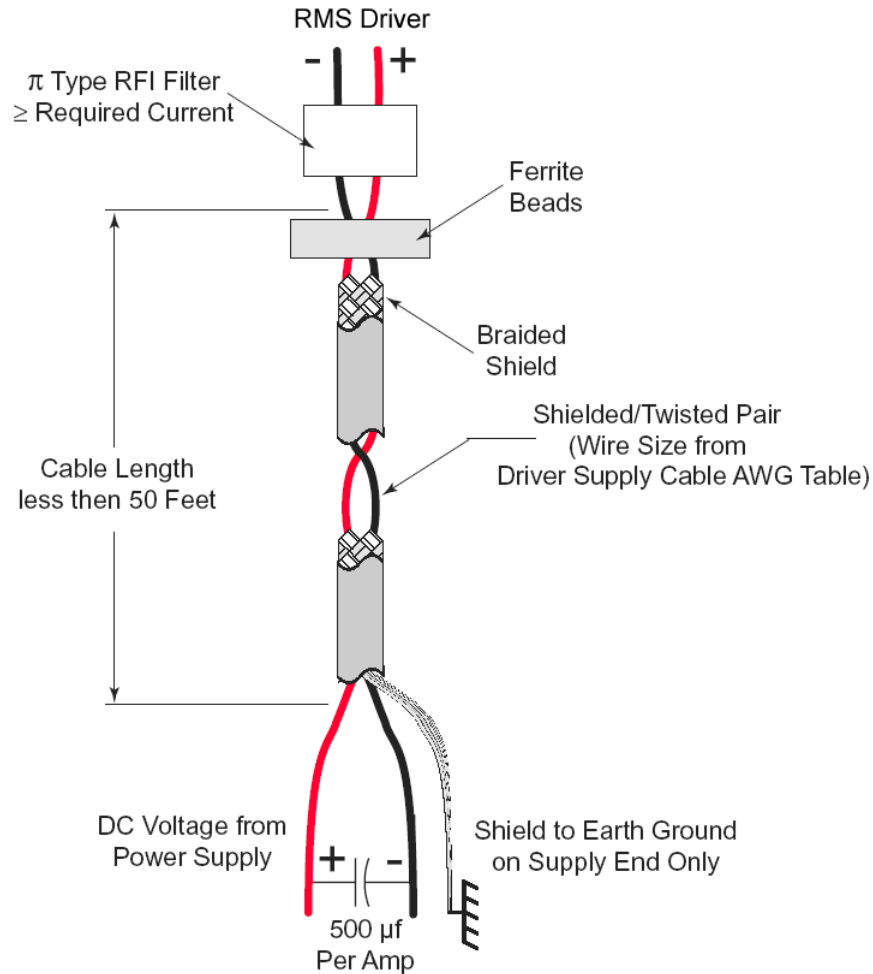

Example A – Cabling Under 50 Feet, DC Power

Example A demonstrates the recommended cable configuration for DC power supply cabling under 50 feet long. If cabling of 50 feet or longer is required, the additional length may be gained by adding an AC power supply cable.

Correct AWG wire size is determined by the current requirement plus cable length. Please see the Driver Supply Cable AWG Table in this Appendix.

**NOTE:** These recommendations will provide optimal protection against EMI and RFI. The actual cable type, wire gauge, shield type and filtering devices used are dependent on the customer's application and system.

Driver Supply Cable AWG Table					
1 Amp (Peak)					
Length (Feet)	10	25	50*	75*	100*
Minimum AWG	20	20	18	18	16
2 Amps (Peak)					
Length (Feet)	10	25	50*	75*	100*
Minimum AWG	20	18	16	14	14
3 Amps (Peak)					
Length (Feet)	10	25	50*	75*	100*
Minimum AWG	18	16	14	12	12
* Use the alternative methods illustrated in Examples B and C when the cable length is $\geq 50$ feet. Also, use the same current rating when the alternate AC power is used					

#### Driver Supply Cable Wire Size

**NOTE:** Always use Shielded/Twisted Pairs for the Driver DC Supply Cable, the AC Supply Cable and the Driver to Motor Cable.



**Recommended Cable Configurations: Driver to Motor**

Cable length, wire gauge and power conditioning devices play a major role in the performance of your Driver and Motor.

NOTE: The length of the DC power supply cable between the Driver and the Motor should not exceed 50 feet.

Example A demonstrates the recommended cable configuration for the Driver to Motor cabling under 50 Feet long.

Correct AWG wire size is determined by the current requirement plus cable length. Please see the Driver to Motor Cable AWG Table in this Appendix.

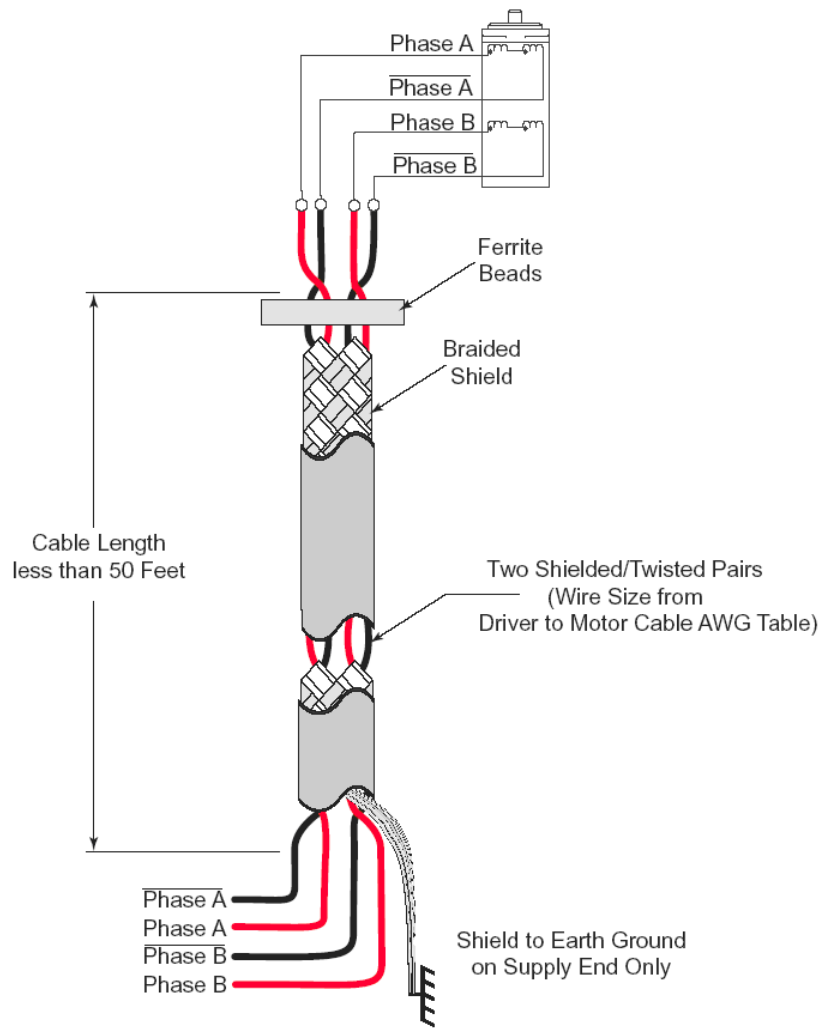

Example A - Cabling Under 50 Feet, Driver to Motor

If cabling of 50 feet or longer is required, the additional length can be gained by adding Common Mode Line Filters (2x)

\*L ≈ 0.5 MH

\* 0.5 MH is a typical starting point for the Common Mode Line Filters. By increasing or decreasing the value of L you can set the drain current to a minimum to meet your requirements.

Driver to Motor Cable AWG Table											
	1 Amp (Peak)						5 Amp (Peak)				
Length (Feet)	10	25	50	75	100	Length (Feet)	10	25	50	75	100
Minimum AWG	20	20	18	18	16	Minimum AWG	16	16	14	12	12
	2 Amp (Peak)						6 Amp (Peak)				
Length (Feet)	10	25	50	75	100	Length (Feet)	10	25	50	75	100
Minimum AWG	20	18	16	14	14	Minimum AWG	14	14	14	12	12
	3 Amp (Peak)						7 Amp (Peak)				
Length (Feet)	10	25	50	75	100	Length (Feet)	10	25	50	75	100
Minimum AWG	18	16	14	12	12	Minimum AWG	12	12	12	12	12
	4 Amp (Peak)										
Length (Feet)	10	25	50	75	100						
Minimum AWG	18	16	14	12	12						

#### Driver to Motor Supply Cable Wire Size

**NOTE:** These recommendations will provide optimal protection against EMI and RFI. The actual cable type, wire gauge, shield type and filtering devices used are dependent on the customer's application and system.

**NOTE:** Always use Shielded/Twisted Pairs for the Driver DC Supply Cable, the AC Supply Cable and the Driver to Motor Cable.

## 11. Appendix B: PF Value

For applications requiring ultimate smoothness of motion and extreme accuracy, the R325P driver can be programmed via RS485 to change the Percent Fast Decay rate, or, the PF value.

The Percent Fast Decay default is 2, or a mixed mode of 48%.

Mixed mode is a damping technique done to the driver IC. The following values indicate the choices for Percent Fast Decay:

PF Values (0 through 3):

- 0 = Slow Decay
- 1 = Mixed Mode 15%
- 2 = Mixed Mode 48%
- 3 = 100% Fast Decay

Generally speaking, applications that run at slow speeds are recommended to use a PF value of 1 or less. Fast speeds should use a PF value of 2 or more. Since the best PF value is dependent on the motor winding, loads, power supply voltage, and other factors, it is best to use an oscilloscope and a current probe device to view the current waveform and try different PF values. The following examples show good and bad waveforms when choosing different PF values.

- PF value 1
- Slow speeds
- Good waveform

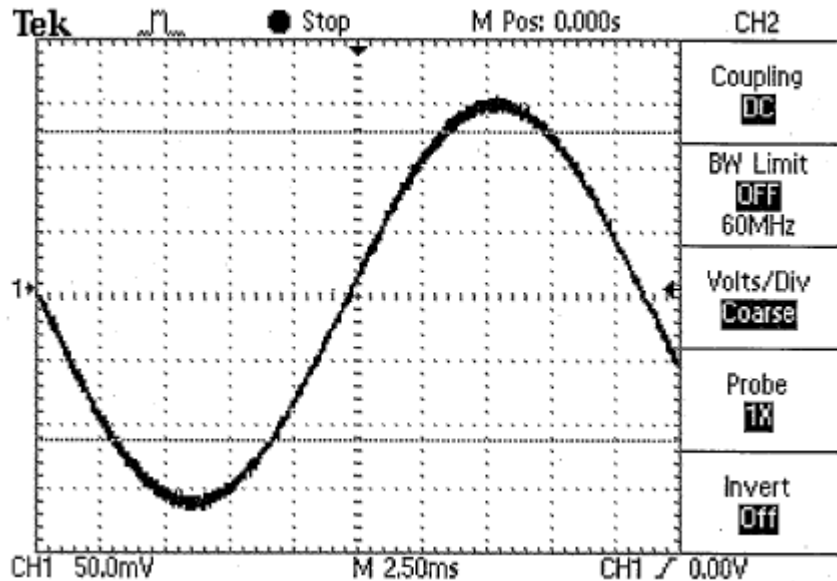

- PF value 3
- Slow speeds
- Bad waveform

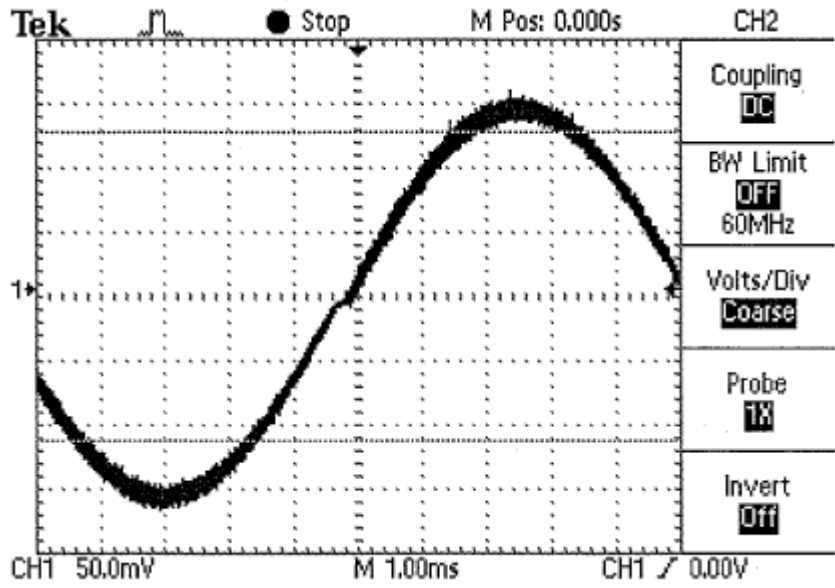

- PF value 1
- Fast speeds
- Bad waveform

