

AIR TECH
SYSTEMS



Technical Documentation

LTG Combustion Air Centrifugal Fans

Series VRA 53/.../..., VRA 54/.../..., VRA 55/.../..

Verbrennungsluft-Radialventilatoren Typenreihe

VRA 53/.../..
VRA 54/.../..
VRA 55/.../..

| Inhalt | Seite |
|---|--------------|
| VRA 5/.../.. Einsatz, Lieferprogramm, Spezifikation und konstruktive Merkmale, Motor, Vor- teile | 3 |
| VRA 5/.../.. Technische Daten | 4 |
| VRA 53/.../.. Abmessungen, Gehäusestellungen | 5 |
| VRA 53/.../.. Kennlinien: ab Baugröße 80 bis 200 | 6 |
| VRA 54/.../.. elastische Aufstellung, Abmessungen Baugröße 80 bis 280, Gehäusestellungen | 8 |
| VRA 54/... Kennlinien: ab Baugröße 80 bis 225 | 10 |
| VRA 55/.../.. elastische Aufstellung, Abmessungen Baugröße 63 bis 280, Gehäusestellungen | 13 |
| VRA 55/... Kennlinien: ab Baugröße 63 bis 280 | 15 |
| VRA 5/.../.. Zubehör, Filter, Flansche | 18 |

Hinweise

Die Abmessungen in diesem technischen Prospekt sind in mm angegeben.
Für sie gelten die Allgemeintoleranzen nach DIN ISO 2768-vL.

Combustion Air Centrifugal Fans Types VRA 53/.../.. VRA 54/.../.. VRA 55/.../..

The LTG Combustion Air Centrifugal Fan type VRA 5/.../.. is a one-side suction centrifugal fan with direct drive by a flange-mounted motor or foot motor.

Range of Products

VRA 53/.../..

for static pressure rise 6000 Pa

VRA 54/.../..

for static pressure rise 8000 Pa

VRA 55/.../..

for static pressure rise 10000 Pa

Application

Typical applications include the feeding of industrial furnaces with combustion air when used for hardening or steel coating.

The fan is designed for an operation with free suction.

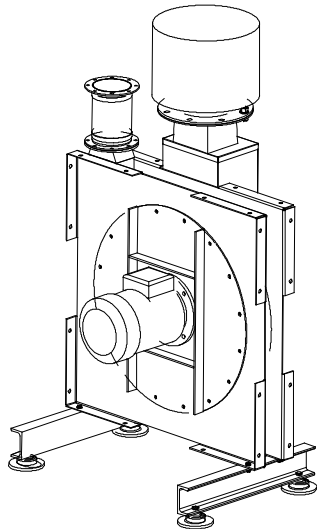

Specification and Design Characteristics

Welded U St 37-2 sheet steel housing with screw connected sound insulated suction box with mounted round air filter (DELBAG fibroidelastic).

Discharge socket with flange.

Impellers of welded U St 37-2 sheet steel.

(size 54/80 - 54/160 und 55/80 - 55/160 of welded aluminum AlMg3).

Hub of cast iron, screwed and dynamically balanced according to DIN ISO 1940, grade 6.3, mounted directly onto the motor shaft.

Surface painted similar to RAL 5003, accessories similar to RAL 9006.

Motor

Alternative standard motors, type IMB 5 or IMB 3, up to 3 kW 230/400 V, from 4 kW 400/690 V, 50 Hz, IP55 protection (with PTC resistor sensor).

Advantages

- **Best aerodynamic properties**
- **Flat conveying characteristic**
for minimum pressure fluctuation during service
- **Great running smoothness**
Impeller dynamically balanced together with hub and shaft
- **Low-noise operation**
- **Compact design**
with sound insulated suction box and air filter
- **Safe design**
Solid, torsion-stiff steel housing, welded, screwed, painted
- **High-precision production**
ensures that specification requirements are always met
- **Great selection of types**
3 Series with up to 10 sizes each for flow rates of up to 6,300 m³/h and static pressures of up to 10,000 Pa.
- **Computer designed**
Based on selection criteria, LTG fans are computer designed and dimensioned to meet any individual requirements. Thus, the fan suiting your application best will always be found.



Combustion Air Centrifugal Fans Types VRA 53/.../.. VRA 54/.../.. VRA 55/.../..

Technical Data

| Size | Flow rate | Total pressure rise | Motor output | Motor-type | Speed | Sound pressure level 1) | Weight | | Filter-type | Filter weight |
|-------------------|---------------------|---------------------|--------------|------------|----------------------|-------------------------|----------|--------------|-------------|---------------|
| | [m ³ /h] | [mbar=hPa] | [kW] | [-] | [min ⁻¹] | [dB(A)] | Fan [kg] | Chassis [kg] | [kg] | [kg] |
| VRA 53/ 80 | 400 | 60 | 3.0 | IMB 5 | 2905 | 74 | 120 | 13 | DC-03 | 2.3 |
| 100 | 600 | 58 | 3.0 | IMB 5 | 2905 | 75 | 125 | 13 | DC-03 | 2.3 |
| 125 | 950 | 62 | 5.5 | IMB 5 | 2945 | 76 | 151 | 13 | DC-2 | 8.0 |
| 140 | 1250 | 64 | 5.5 | IMB 5 | 2950 | 78 | 150 | 15 | DC-2 | 8.0 |
| 180 | 2000 | 66 | 7.5 | IMB 5 | 2950 | 79 | 185 | 15 | DC-3 | 12.0 |
| 200 | 3500 | 65 | 11.0 | IMB 5 | 2955 | 80 | 220 | 15 | DC-5 | 21.0 |
| VRA 54/ 80 | 480 | 81 | 3.0 | IMB 5 | 2905 | 75 | 140 | 13 | DC-03 | 2.3 |
| 100 | 750 | 82 | 4.0 | IMB 5 | 2945 | 76 | 160 | 13 | DC-2 | 8.0 |
| 125 | 1100 | 82 | 5.5 | IMB 5 | 2950 | 77 | 180 | 13 | DC-2 | 8.0 |
| 140 | 1400 | 83 | 7.5 | IMB 5 | 2950 | 78 | 200 | 15 | DC-2 | 8.0 |
| 160 | 1900 | 81 | 11.0 | IMB 5 | 2955 | 79 | 240 | 17 | DC-3 | 12.0 |
| 180 | 2600 | 82 | 15.0 | IMB 3 | 2955 | 80 | 290 | 30 | DC-3 | 12.0 |
| 200 | 3200 | 82 | 18.5 | IMB 3 | 2955 | 81 | 320 | 30 | DC-4 | 17.0 |
| 225 | 4000 | 82 | 22.0 | IMB 3 | 2940 | 82 | 380 | 30 | DC-5 | 21.0 |
| 250 | 5000 | 82 | 30.0 | IMB 3 | 2960 | 83 | 480 | 36 | DC-5 | 21.0 |
| 280 | 6300 | 82 | 30.0 | IMB 3 | 2960 | 85 | 520 | 36 | 2 x DC-4 | 2 x 17.0 |
| VRA 55/ 63 | 250 | 103 | 4 | IMB 5 | 2945 | 76 | 155 | 13 | DC-03 | 2.3 |
| 80 | 480 | 100 | 4 | IMB 5 | 2945 | 76 | 160 | 13 | DC-03 | 2.3 |
| 100 | 720 | 101 | 5.5 | IMB 5 | 2950 | 78 | 190 | 13 | DC-2 | 8.0 |
| 125 | 1140 | 101 | 7.5 | IMB 5 | 2950 | 79 | 215 | 13 | DC-2 | 8.0 |
| 160 | 1860 | 101 | 11 | IMB 5 | 2955 | 80 | 280 | 17 | DC-3 | 12.0 |
| 180 | 2280 | 101 | 15.0 | IMB 3 | 2955 | 82 | 325 | 30 | DC-3 | 12.0 |
| 200 | 2940 | 102 | 18.5 | IMB 3 | 2955 | 84 | 360 | 30 | DC-4 | 17.0 |
| 225 | 3720 | 102 | 22.0 | IMB 3 | 2940 | 85 | 415 | 30 | DC-5 | 21.0 |
| 250 | 4380 | 102 | 30.0 | IMB 3 | 2960 | 86 | 530 | 36 | Dc-5 | 21.0 |
| 280 | 5520 | 102 | 37.0 | IMB 3 | 2960 | 87 | 585 | 36 | 2 x DC-4 | 2 x 17.0 |

1) measured from a distance of 1 m with the pressure line connected.

Combustion Air Centrifugal Fan Type VRA 53/.../..

Dimensions

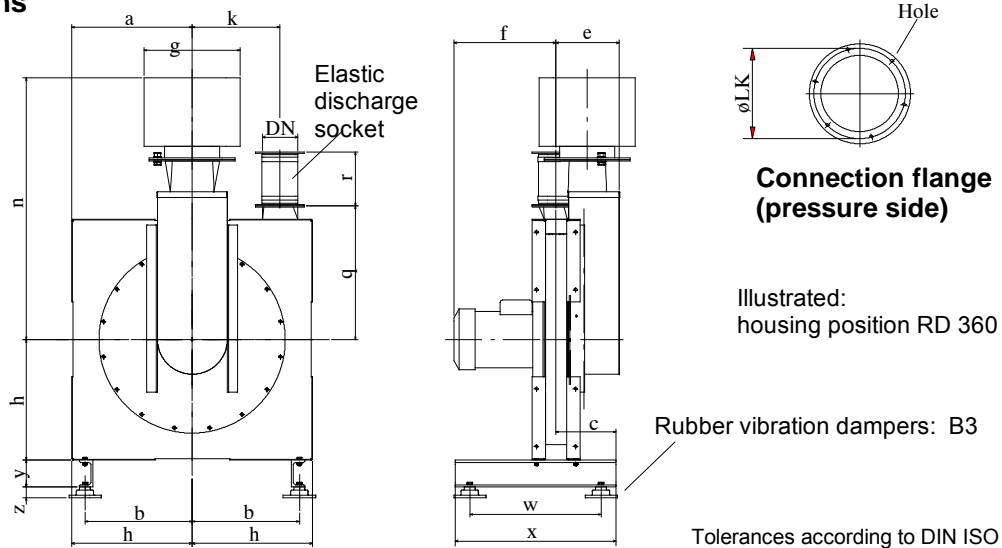

| Size VRA 53 | 80 | 100 | 125 | 140 | 180 | 200 |
|---------------------|-------|-------|-------|-------|--------|-----|
| a | 450 | 450 | 450 | 500 | 500 | |
| b | 400 | 400 | 400 | 450 | 450 | |
| c | 223 | 223 | 223 | 283 | 298 | |
| DN | 80 | 100 | 125 | 140 | 180 | |
| LK | 114 | 135 | 161 | 180 | 217 | |
| Hole Ø | 9.5 | 9.5 | 9.5 | 9.5 | 9.5 | |
| No. of holes | 4 | 4 | 8 | 8 | 8 | |
| e | 236 | 239 | 237.5 | 287.5 | 302.5 | |
| f | 360 | 360 | 433 | 431.5 | 446.5 | |
| g | 180 | 180 | 360 | 360 | 360 | |
| h | 450 | 450 | 450 | 500 | 500 | |
| k | 350 | 340.5 | 327.5 | 379.5 | 359.5 | |
| n | 772.5 | 802.2 | 976.5 | 976.5 | 1166.5 | |
| q | 500 | 500 | 500 | 500 | 500 | |
| r | 200 | 200 | 200 | 200 | 150 | |
| w | 490 | 490 | 490 | 590 | 590 | |
| x | 600 | 600 | 600 | 700 | 700 | |
| y | 100 | 100 | 100 | 100 | 100 | |
| z | 40.5 | 40.5 | 40.5 | 40.5 | 40.5 | |

Housing positions (view onto motor side)

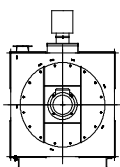

position RD 360

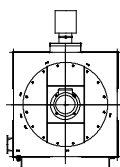

position RD 270

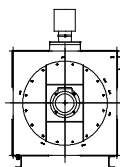

position RD 90

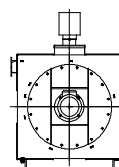

position LG 90

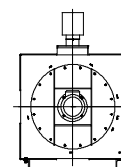

position LG 270

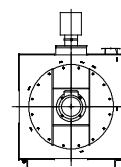

position LG 360

Combustion Air Centrifugal Fan Type VRA 53/... Sizes 80 - 140

Characteristics (at 20 °C, $\rho = 1.2 \text{ kg/m}^3$)

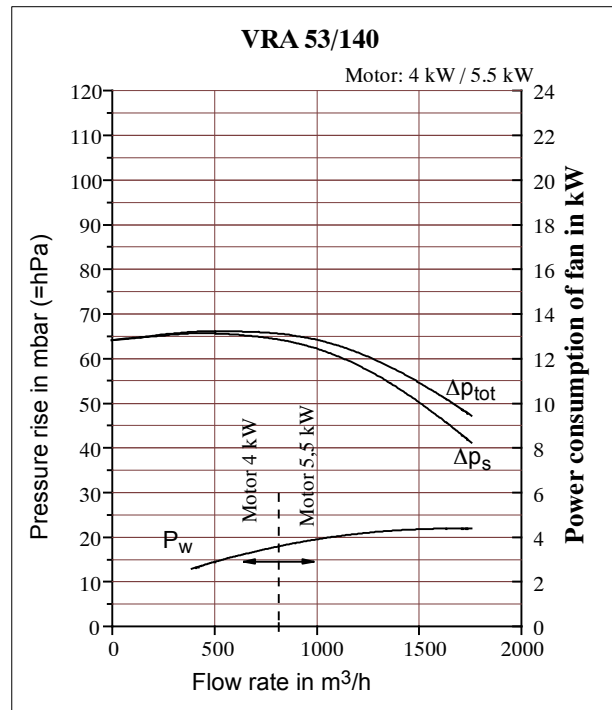
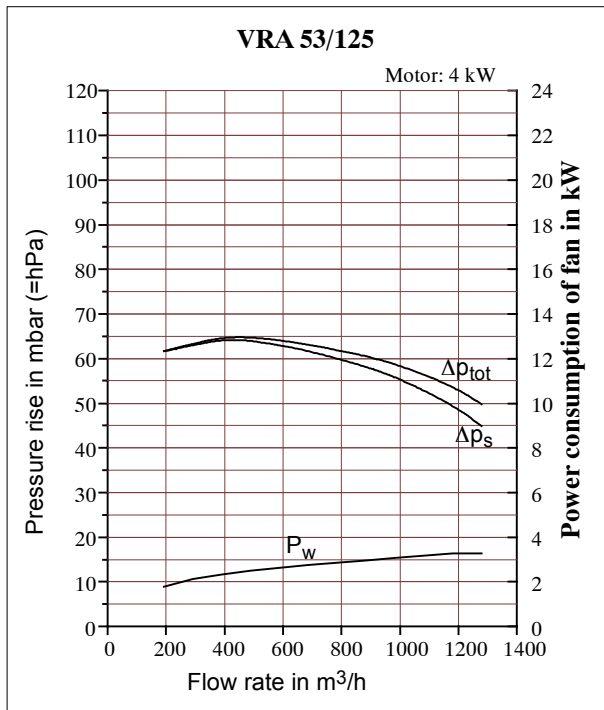
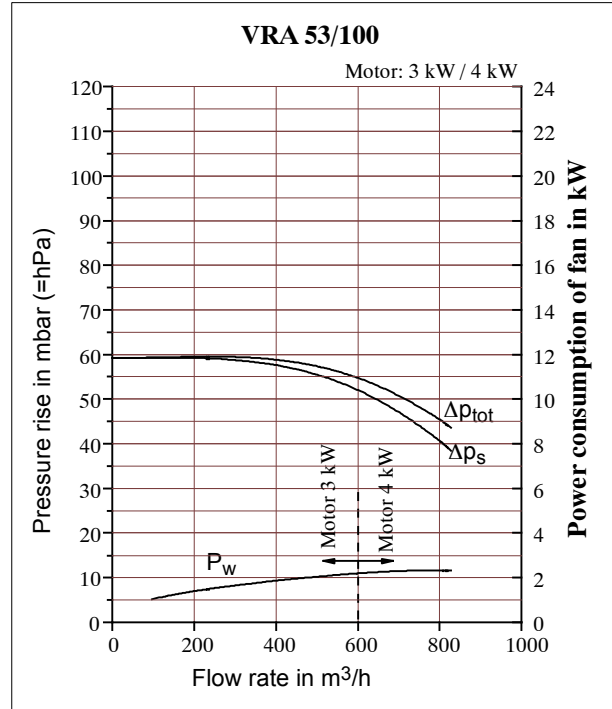
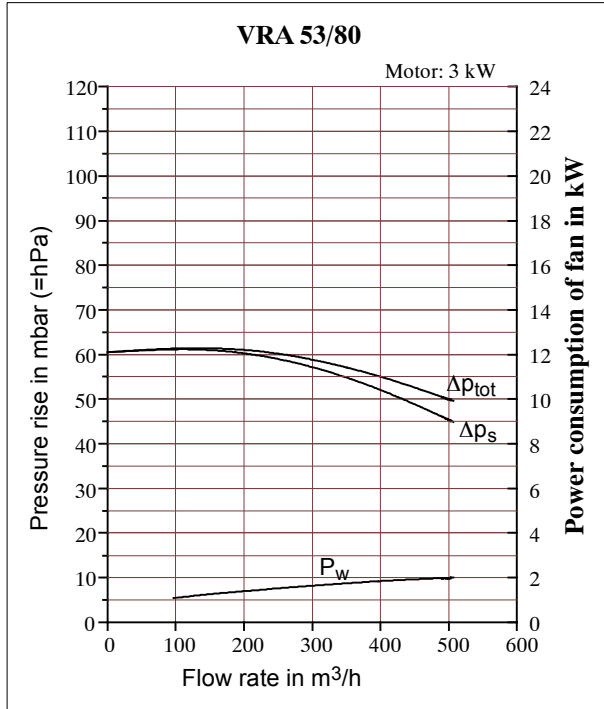

Combustion Air Centrifugal Fan Type VRA 53/... Sizes 180 - 200

Characteristics (at 20 °C, $\rho = 1.2 \text{ kg/m}^3$)

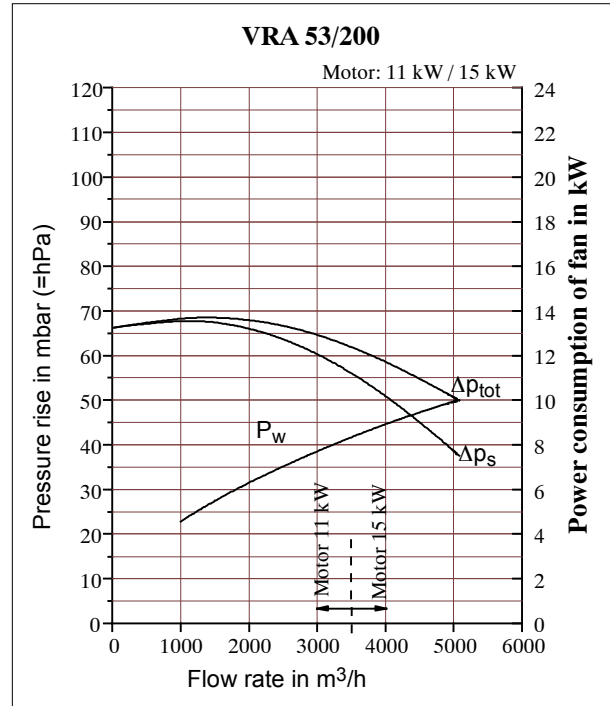
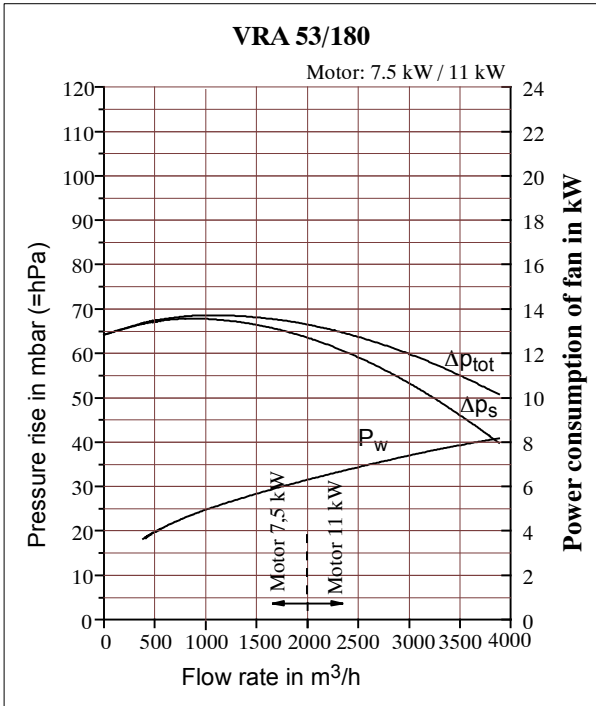

Combustion Air Centrifugal Fan Type VRA 54/.../.. elastic Installation, Sizes 80 - 160

Dimensions

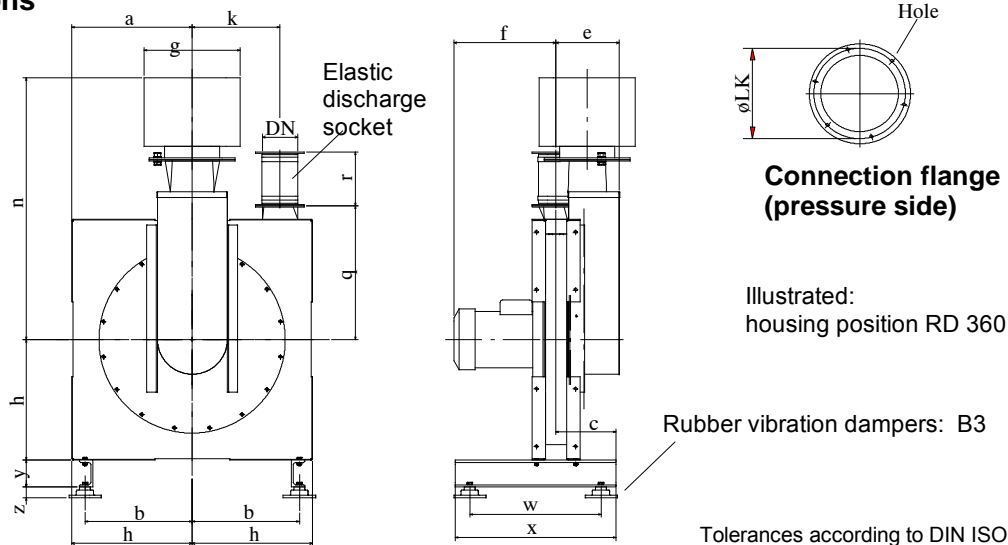

| Size VRA 54 | 80 | 100 | 125 | 140 | 160 |
|-------------------------------|-------|-------|-------|-------|--------|
| a | 480 | 480 | 480 | 520 | 520 |
| b | 430 | 430 | 430 | 470 | 470 |
| c | 233 | 233 | 233 | 235 | 290 |
| DN | 80 | 100 | 125 | 140 | 160 |
| LK | 114 | 135 | 161 | 180 | 198 |
| Hole ϕ | 9.5 | 9.5 | 9.5 | 9.5 | 9.5 |
| No. of holes | 4 | 4 | 8 | 8 | 8 |
| e | 249 | 249 | 249 | 249 | 295.5 |
| f | 371 | 393 | 432.5 | 432.5 | 545.45 |
| g | 180 | 360 | 360 | 360 | 360 |
| h | 480 | 480 | 480 | 520 | 520 |
| k | 380 | 370 | 370 | 410 | 400 |
| n | 772.5 | 946.5 | 946.5 | 945 | 1166.5 |
| q | 530 | 530 | 540 | 580 | 570 |
| r | 200 | 200 | 200 | 200 | 150 |
| w | 490 | 490 | 490 | 490 | 690 |
| x | 600 | 600 | 600 | 600 | 800 |
| y | 100 | 100 | 100 | 100 | 100 |
| z | 40.5 | 40.5 | 40.5 | 40.5 | 40.5 |

Housing positions (view onto suction side)

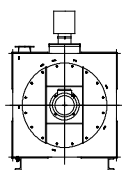

position RD 360

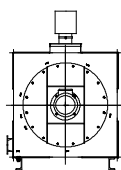

position RD 270

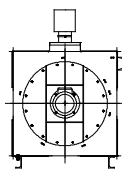

position RD 90

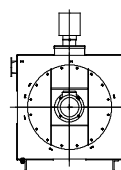

position LG 90

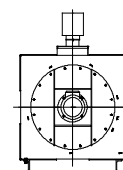

position LG 270

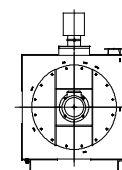

position LG 360

Combustion Air Centrifugal Fan Type VRA 54/.../.. elastic Installation, Sizes 180 - 280

Dimensions

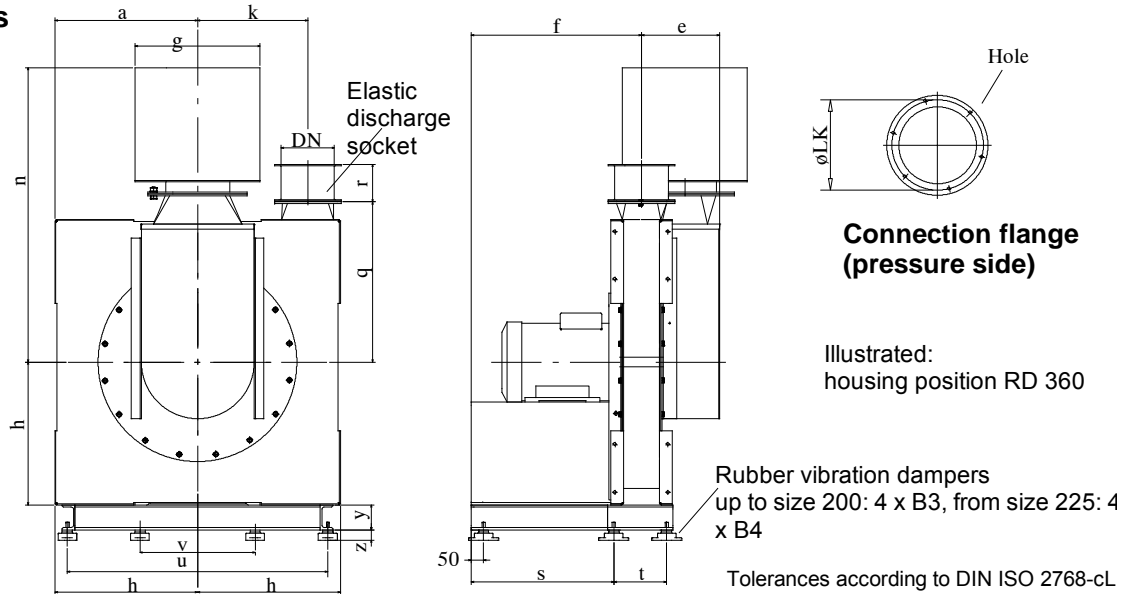

| Size VRA 54 | 180 | 200 | 225 | 250 | 280 |
|--------------|--------|--------|-----|-----|-----|
| a | 520 | 570 | | | |
| DN | 180 | 200 | | | |
| LK | 217 | 239 | | | |
| Hole Ø | 9.5 | 9.5 | | | |
| No. of holes | 8 | 8 | | | |
| e | 353 | 423 | | | |
| f | 573 | 680.5 | | | |
| g | 360 | 500 | | | |
| h | 520 | 570 | | | |
| k | 390 | 440 | | | |
| n | 1166.5 | 1176.5 | | | |
| q | 580 | 640 | | | |
| r | 150 | 150 | | | |
| s | 470 | 570 | | | |
| t | 196 | 211 | | | |
| u | 940 | 1040 | | | |
| v | 410 | 460 | | | |
| y | 100 | 100 | | | |
| z | 40.5 | 40.5 | | | |

Housing positions (view onto motor side)

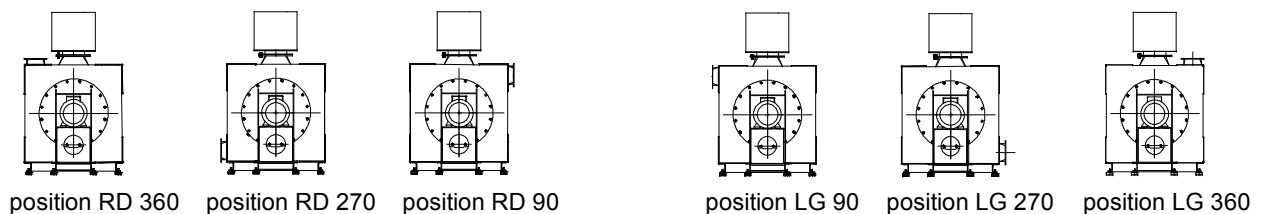

Combustion Air Centrifugal Fan Type VRA 54/... Sizes 80 - 140

Characteristics (at 20 °C, $\rho = 1.2 \text{ kg/m}^3$)

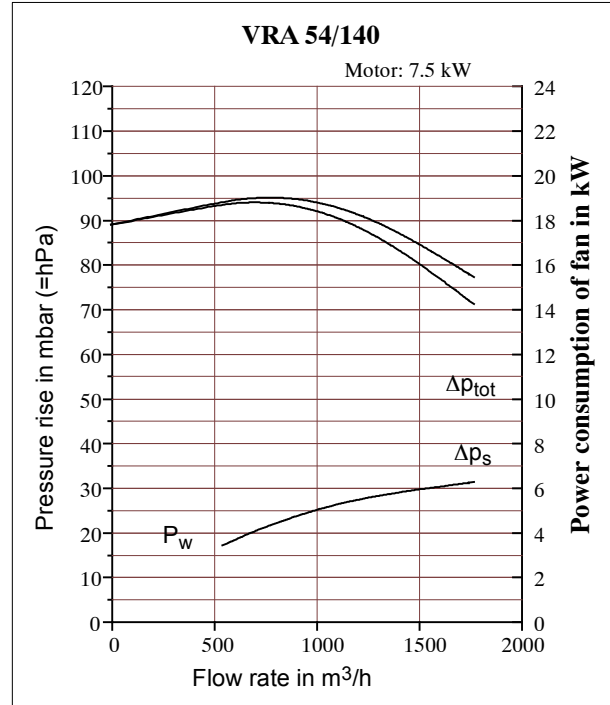
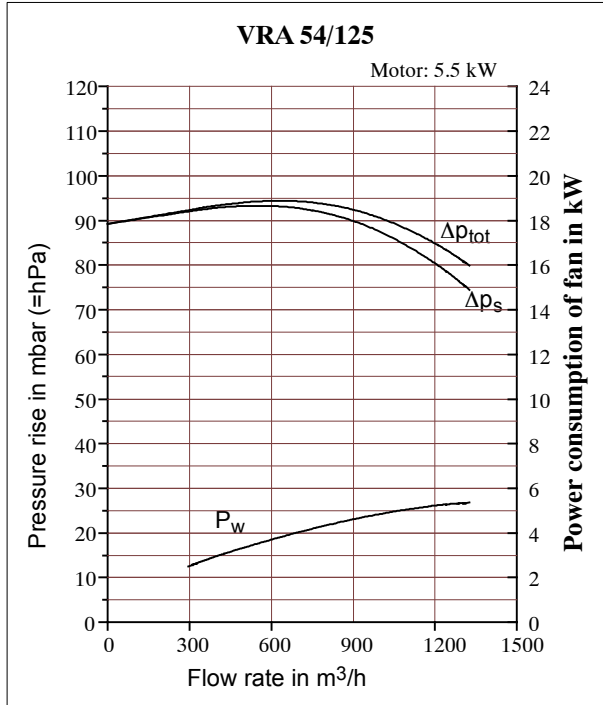
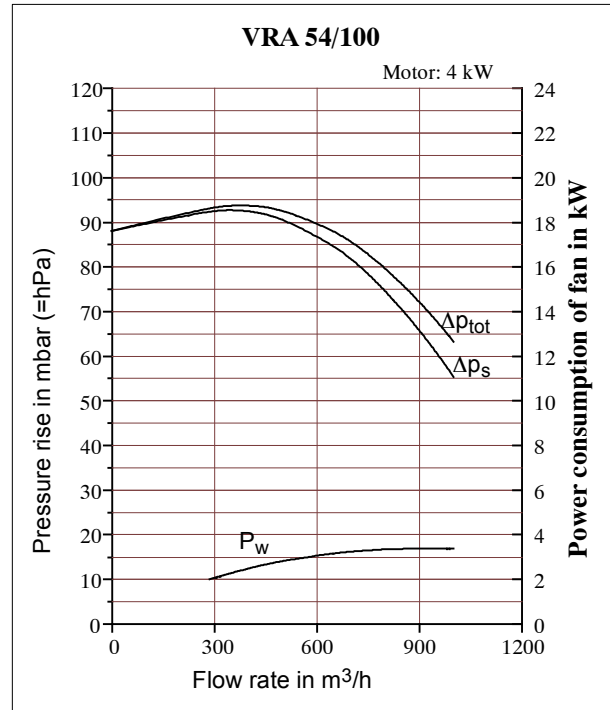
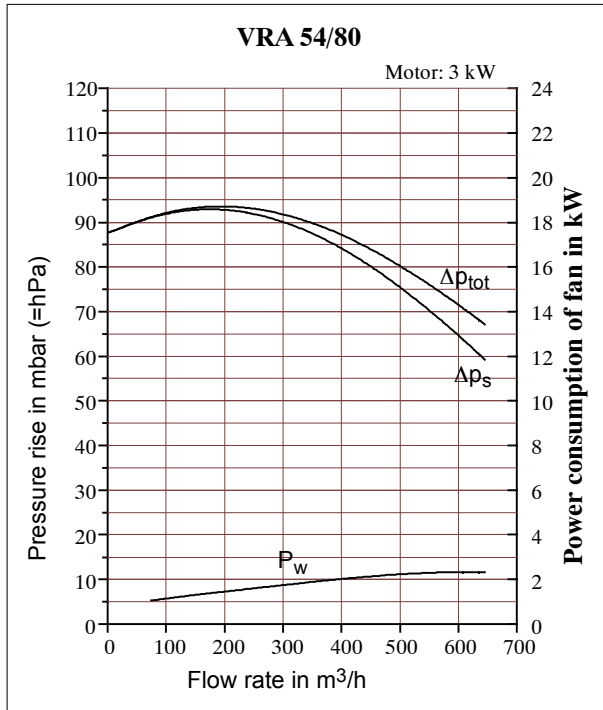

Combustion Air Centrifugal Fan Type VRA 54/... Sizes 160 - 225

Characteristics (at 20 °C, $\rho = 1.2 \text{ kg/m}^3$)

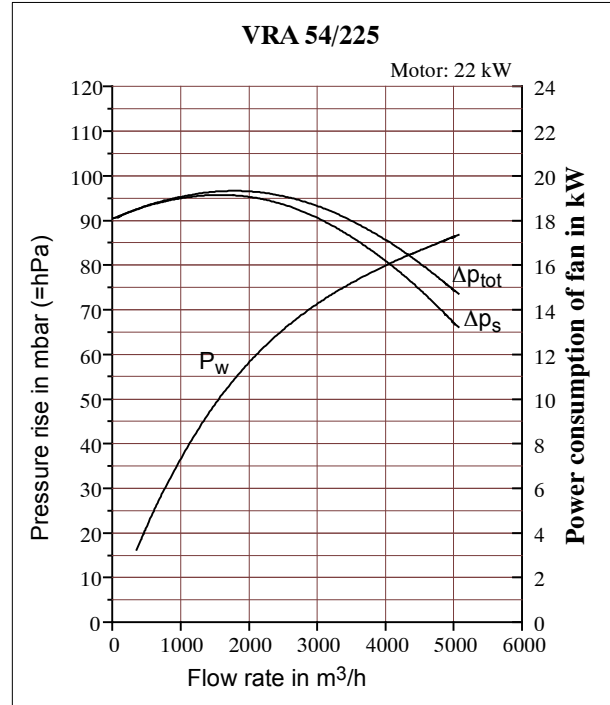
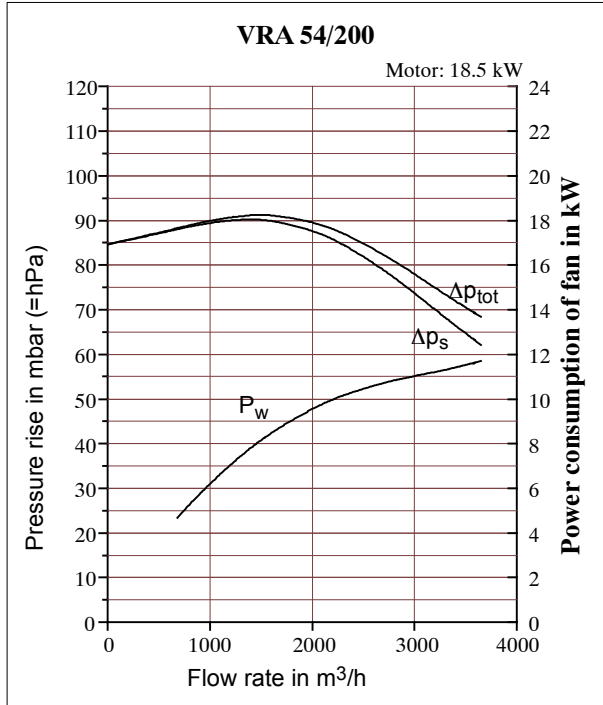
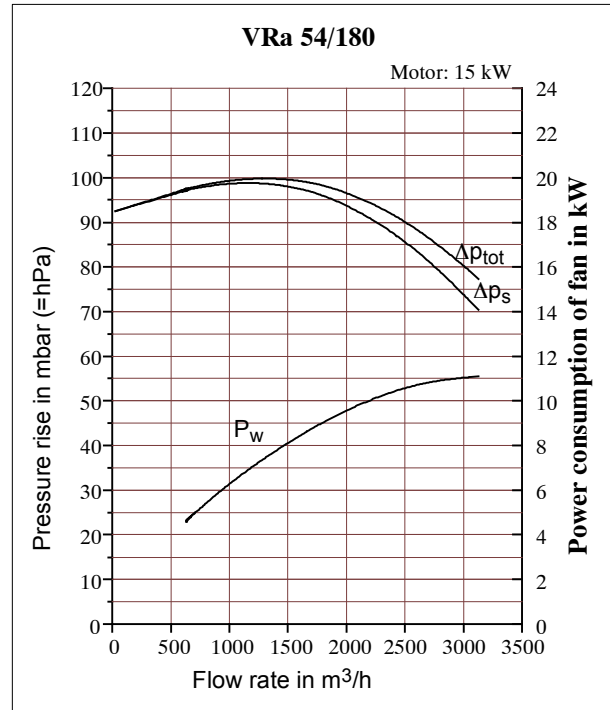
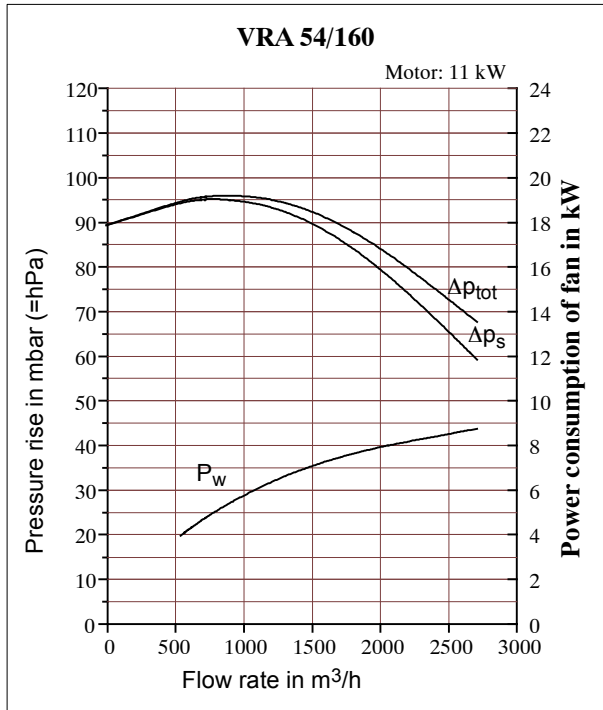

Combustion Air Centrifugal Fan Type VRA 54/... Sizes 250 - 280

Characteristics (at 20 °C, $\rho = 1.2 \text{ kg/m}^3$)

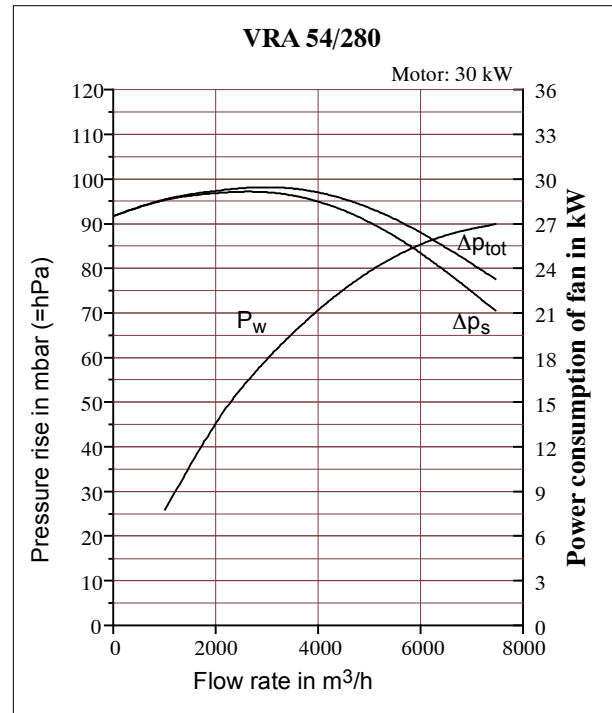
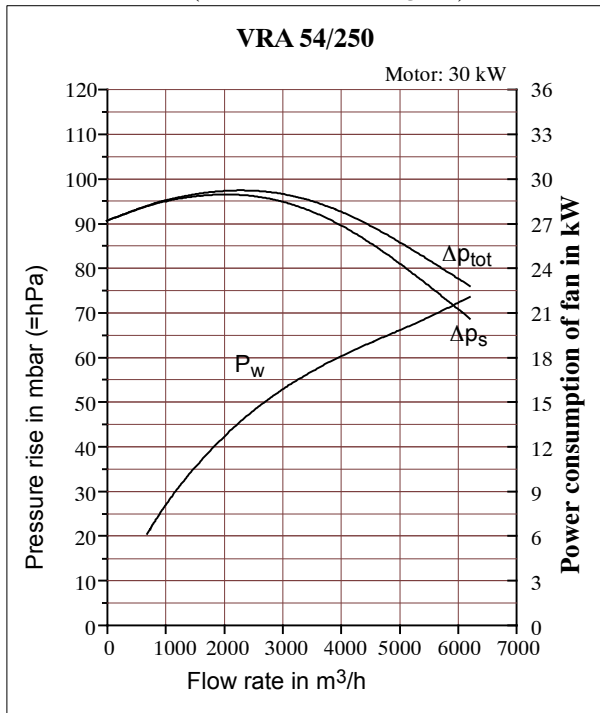

Combustion Air Centrifugal Fan Type VRA 55/.../.. elastic Installation, Sizes 63 - 160

Dimensions

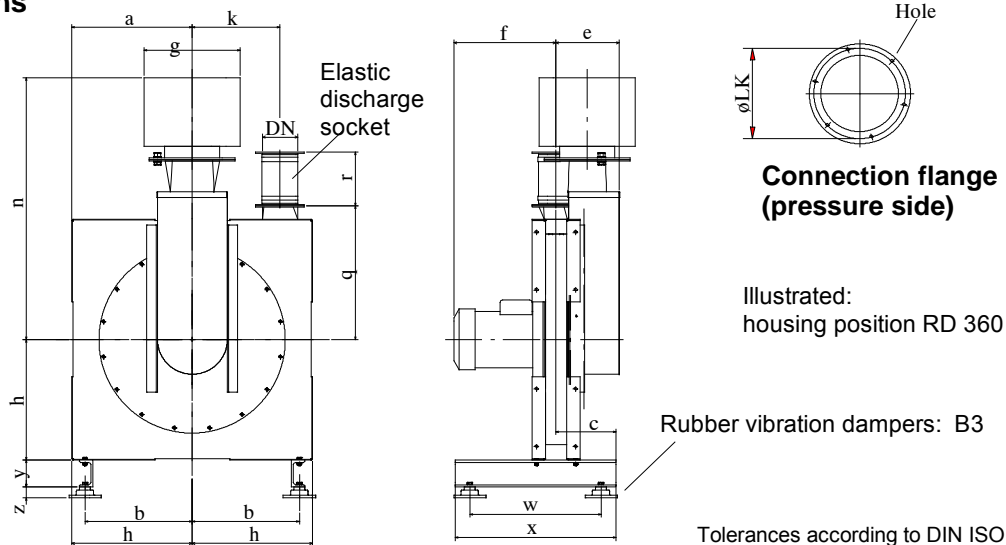

Tolerances according to DIN ISO 2768-cL

| Size VRA 55 | 63 | 80 | 100 | 125 | 140 | 160 |
|--------------|-------|-------|-------|-------|-----|------|
| a | 500 | 500 | 500 | 500 | | 550 |
| b | 450 | 450 | 450 | 450 | | 500 |
| c | 235 | 235 | 235 | 235 | | 292 |
| DN | 63 | 80 | 100 | 125 | | 160 |
| LK | 98 | 114 | 145 | 161 | | 198 |
| Hole Ø | 9.5 | 9.5 | 9.5 | 9.5 | | 9.5 |
| No. of holes | 4 | 4 | 4 | 8 | | 8 |
| e | 250.5 | 249 | 305 | 298 | | 330 |
| f | 390 | 435 | 420 | 432.5 | | 550 |
| g | 180 | 180 | 360 | 360 | | 360 |
| h | 500 | 500 | 500 | 500 | | 550 |
| k | 438.5 | 430 | 422 | 407.5 | | 450 |
| n | 772.5 | 772.5 | 946.5 | 970.5 | | 1175 |
| q | 550 | 550 | 550 | 550 | | 600 |
| r | 200 | 200 | 200 | 200 | | 150 |
| w | 490 | 490 | 490 | 490 | | 690 |
| x | 600 | 600 | 600 | 600 | | 800 |
| y | 100 | 100 | 100 | 100 | | 100 |
| z | 40.5 | 40.5 | 40.5 | 40.5 | | 40.5 |

Housing positions (view onto motor side)

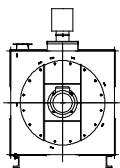

position RD 360

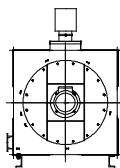

position RD 270

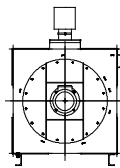

position RD 90

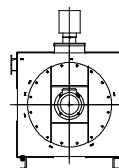

position LG 90

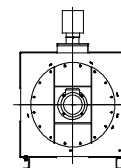

position LG 270

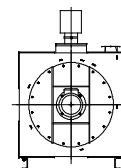

position LG 360

Combustion Air Centrifugal Fan Type VRA 55/.../.. elastic Installation, Sizes 180 - 280

Dimensions

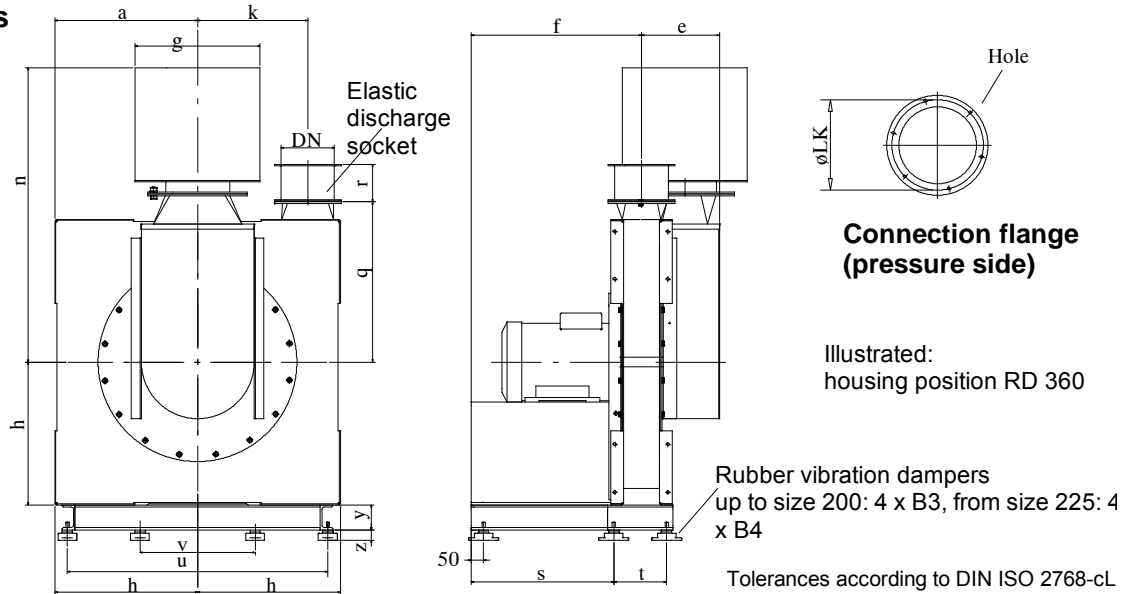

| Size VRA 55 | 180 | 200 | 225 | 250 | 280 |
|--------------|--------|------|-----|------|-----|
| a | 550 | 600 | | 650 | |
| DN | 180 | 200 | | 250 | |
| LK | 217 | 239 | | 290 | |
| Hole Ø | 9,5 | 9,5 | | 9.5 | |
| No. of holes | 8 | 8 | | 12 | |
| e | 304 | 312 | | 324 | |
| f | 574 | 677 | | 794 | |
| g | 500 | 500 | | 500 | |
| h | 550 | 600 | | 650 | |
| k | 440 | 492 | | 465 | |
| n | 1176,5 | 1200 | | 1400 | |
| q | 620 | 650 | | 710 | |
| r | 150 | 150 | | 150 | |
| s | 652 | 770 | | --- | |
| t | --- | --- | | 118 | |
| u | 1000 | 1100 | | 1200 | |
| v | 394 | 460 | | 570 | |
| y | 100 | 100 | | 140 | |
| z | 40,5 | 40,5 | | 50 | |

Housing positions (view onto motor side)

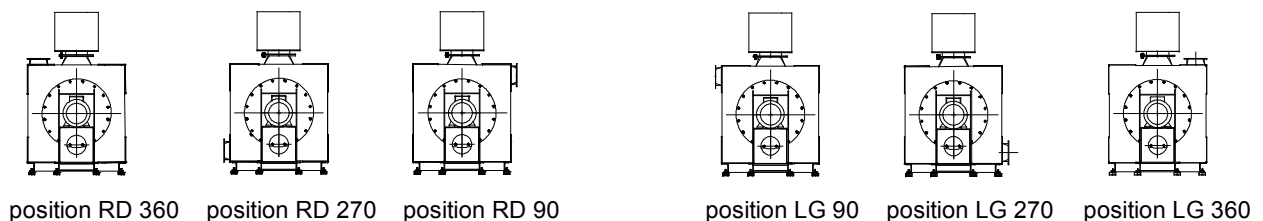

Combustion Air Centrifugal Fan Type VRA 55/... Sizes 63 - 125

Characteristics (at 20 °C, $\rho = 1.2 \text{ kg/m}^3$)

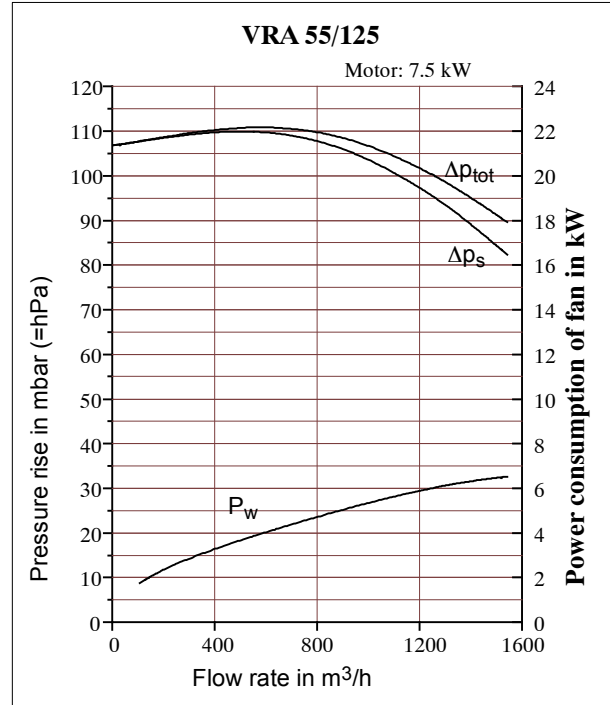
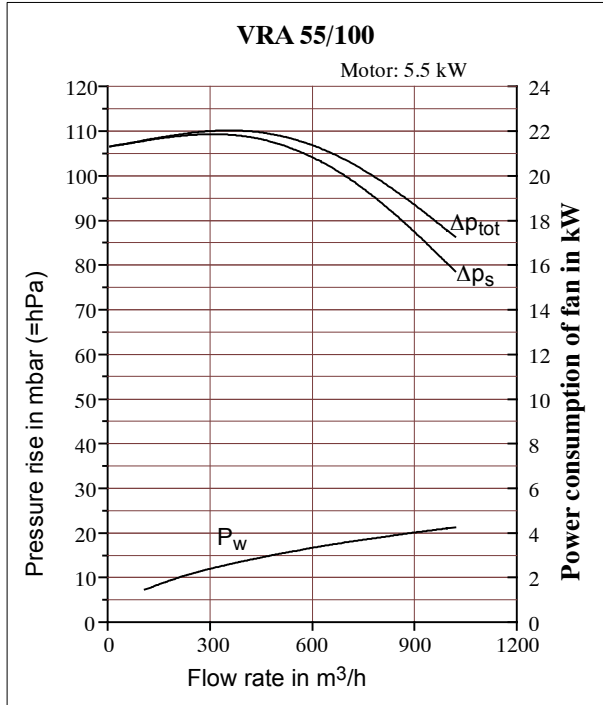
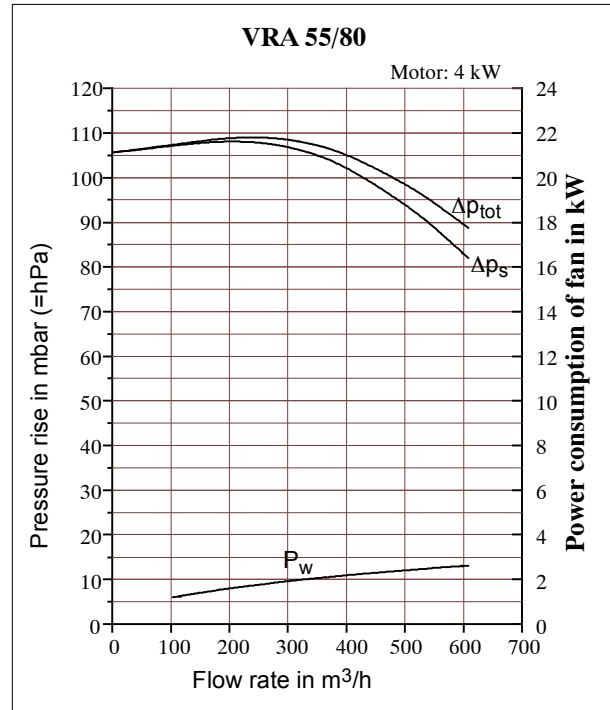
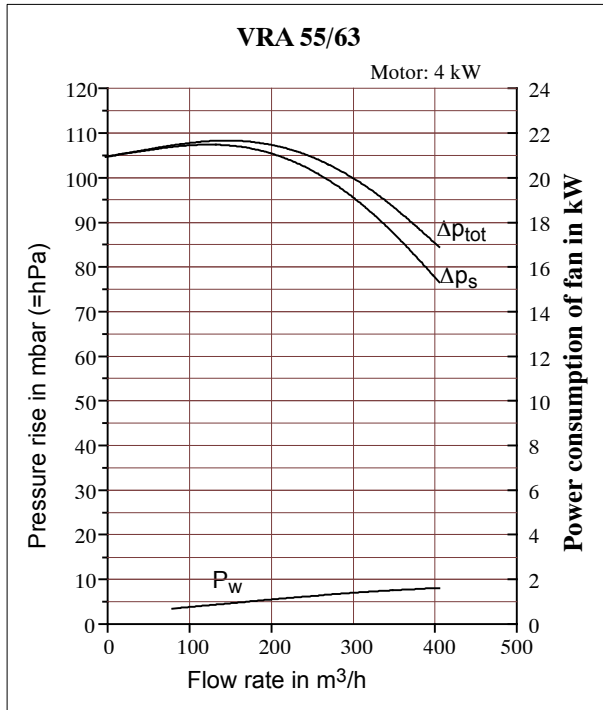

Combustion Air Centrifugal Fan Type VRA 55/... Sizes 160 - 225

Characteristics (at 20 °C, $\rho = 1.2 \text{ kg/m}^3$)

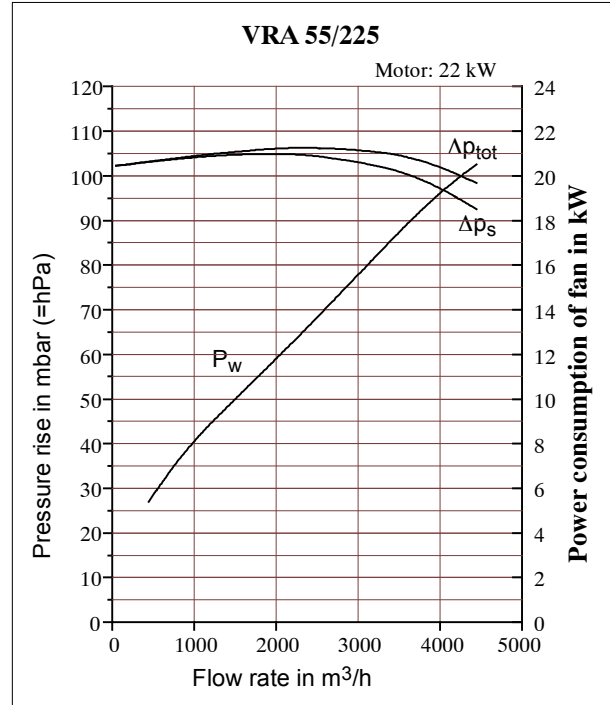
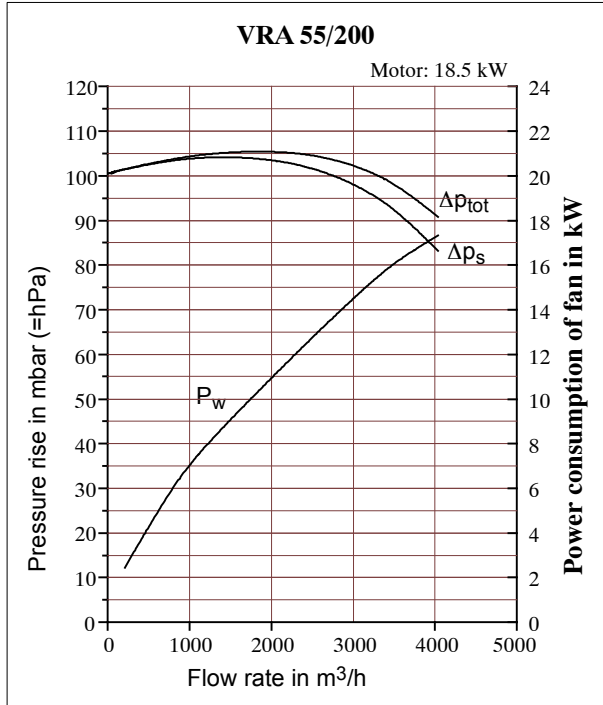
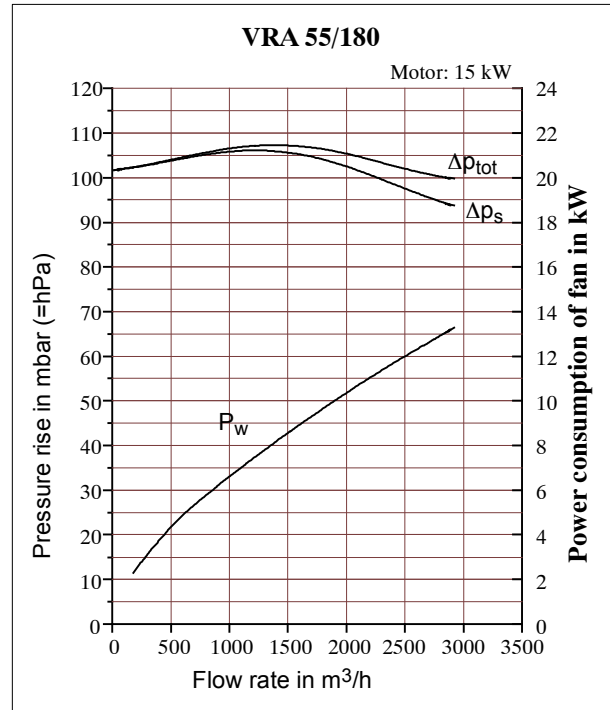
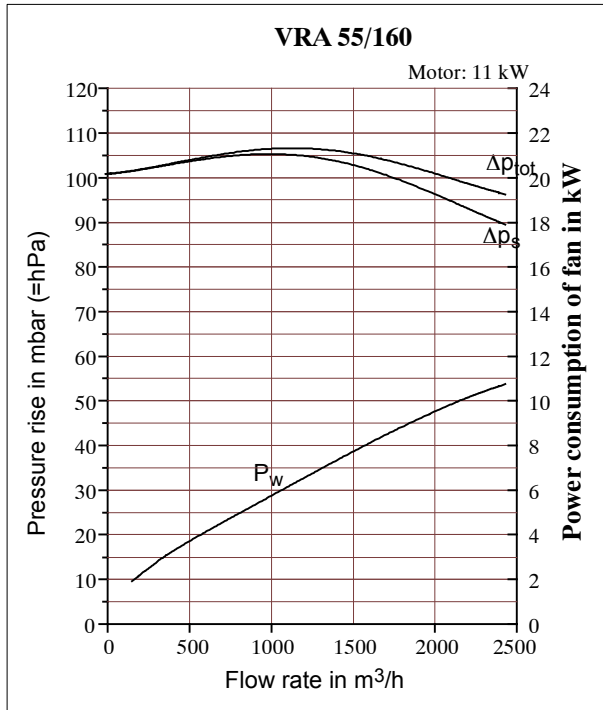

Combustion Air Centrifugal Fan Type VRA 55/... Sizes 250 - 280

Characteristics (at 20 °C, $\rho = 1.2 \text{ kg/m}^3$)

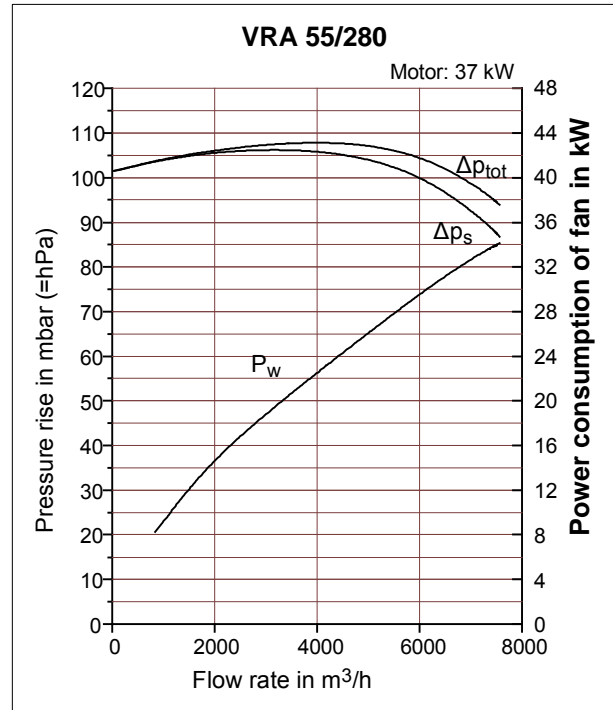
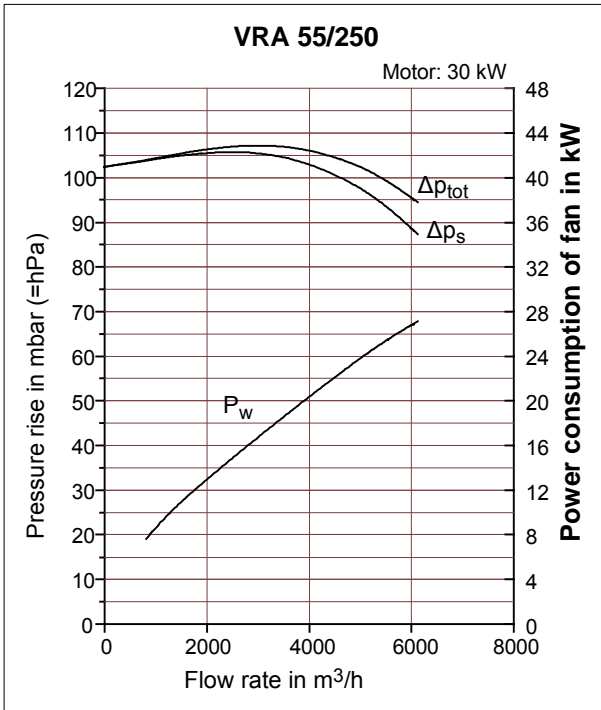

Combustion Air Centrifugal Fans Types **VRA 53/.../..** **VRA 54/.../..** **VRA 55/.../..**

Accessories

Elastic installation:

Lower base or base frame of U sectional steel with 4 rubber vibration dampers.

Elastic connection to the pressure line:

Elastic discharge socket with inner sheet steel sleeve to reduce sound emission.

| Size | Vibration damper | | Elastic discharge socket |
|-------------------|------------------|-----------------------|--------------------------|
| | type | weight [kg / Satz] | weight [kg] |
| VRA 53/ 80 | B3 | 2 | 2 |
| 100 | B3 | 2 | 2 |
| 125 | B3 | 2 | 3 |
| 140 | B3 | 2 | 4 |
| 180 | B3 | 2 | 4 |
| 200 | B3 | 2 | 5 |
| <hr/> | | | |
| VRA 54/ 80 | B3 | 2 | 2 |
| 100 | B3 | 2 | 2 |
| 125 | B3 | 2 | 3 |
| 140 | B3 | 2 | 4 |
| 160 | B3 | 2 | 4 |
| 180 | B3 | 2 | 4 |
| 200 | B3 | 2 | 5 |
| 225 | B4 | 4 | 5 |
| 250 | B4 | 4 | 6 |
| 280 | B4 | 4 | 7 |
| <hr/> | | | |
| VRA 55/ 63 | B3 | 2 | 2 |
| 80 | B3 | 2 | 2 |
| 100 | B3 | 2 | 2 |
| 125 | B3 | 2 | 3 |
| 160 | B3 | 2 | 4 |
| 180 | B3 | 2 | 4 |
| 200 | B3 | 2 | 5 |
| 225 | B4 | 4 | 5 |
| 250 | B4 | 4 | 6 |
| 280 | B4 | 4 | 7 |

Filter

LTG Combustion Air Centrifugal Fans are standard equipped with round air filters for intake air cleaning.

Filters are mounted directly to the suction flange of the fan (flange meeting DIN 2641 or DIN 2642 requirements).

Filters meet filter class EU2 requirements according to DIN EN 779.

The filtering layer is made of a self-extinguishing impregnated natural / synthetic fiber mixture.

The filtering layer is exchangeable and may be reused after cleaning.

| Type | Ø | Height | Filter-weight | Weight per pack |
|--------------|------|--------|---------------|-----------------|
| | [mm] | [mm] | [kg] | [kg] |
| DC-03 | 180 | 250 | 2.3 | 0.4 |
| DC-2 | 360 | 305 | 8.0 | 0.8 |
| DC-3 | 360 | 505 | 12.0 | 1.6 |
| DC-4 | 500 | 505 | 17.0 | 2.2 |
| DC-5 | 500 | 705 | 21.0 | 3.3 |

Flanges

The Combustion Air Centrifugal Fans are provided with flanges on the pressure side (for pitch circle diameter, number of holes, and hole diameter refer to the dimensional sheets of the fan).

| Nom.-Ø | Inside-Ø | Section | Bolt | Weight |
|------------|----------|---------|-----------|--------|
| | [mm] | [mm] | [-] | [kg] |
| 63 | 68 | 25 x 5 | M 8 x 25 | 0.25 |
| 80 | 84 | 25 x 5 | M 8 x 25 | 0.33 |
| 100 | 105 | 25 x 5 | M 8 x 25 | 0.40 |
| 125 | 131 | 25 x 5 | M 8 x 25 | 0.48 |
| 140 | 146 | 30 x 6 | M 8 x 30 | 0.62 |
| 160 | 164 | 30 x 6 | M 8 x 30 | 0.86 |
| 180 | 183 | 30 x 6 | M 8 x 30 | 0.94 |
| 200 | 205 | 30 x 6 | M 8 x 30 | 1.04 |
| 224 | 229 | 30 x 6 | M 8 x 30 | 1.15 |
| 250 | 256 | 30 x 6 | M 8 x 30 | 1.27 |
| 280 | 288 | 35 x 6 | M 10 x 35 | 1.64 |



Comfort Air Technology

Air Conditioning Systems

- Decentralized Facade Ventilation Units
- Fan Coil Units
- Induction Units,
Active Chilled Beams

Air Diffusers

- Linear Air Diffusers
- Wall and Floor Mounted Air Diffusers
- Swirl Diffusers
- Industrial and Special Air Diffusers

Air Distribution

- Flow Rate and Pressure Controllers
- Shut-off and Balancing Dampers
- Silencers

Process Air Technology

Fans

- Tangential Fans
- Axial Fans
- Centrifugal Fans
- Fahrtwind-Simulators

Filtration Technology

- Suction Nozzles
- Dampers
- Filters, Dust Collectors
- Separators, Compactors

Humidification Technology

- Air Humidifiers
- Product Humidifiers

Engineering Services

Fluid Engineering

- Flow analysis
- Flow visualization
- CFD-simulations
- Flow optimization
- Air conditioning concepts

Thermodynamics

- Calorimetric performance measurement
- Thermal, dynamic, unsteady,
system simulations

Acoustics

- Sound level measuring
- Vibration analysis
- Echo chamber measurement
- Acoustic optimization

Comfort

- Evaluation
- Optimization

Customer-specific Solutions

- Product development
- Process optimization
- Installation analysis