

Main applications

For pumping and venting of HV systems

(For large gas flows we recommend series 24)



Ordering information

Valve with manual actuator
removable handwheel

	DN		Ordering numbers			
	mm	inch	Angle valve		Inline valve	
			aluminum	stainless steel	aluminum	stainless steel
ISO-KF	10	3/8"	–	26420-KE01	–	–
	16	5/8"	26424-KA01	26424-KE01	26524-KA01	26524-KE01
	25	1"	26428-KA01	26428-KE01	26528-KA01	26528-KE01
	40	1 1/2"	26432-KA01	26432-KE01	26532-KA01	26532-KE01
	50	2"	26434-KA01	26434-KE01	26534-KA01	26534-KE01
ISO-K	63	2 1/2"	26436-QA01	26436-QE01	–	–
	80	3"	26438-QA01	–	26538-QA01	–
	100	4"	26440-QA01	26440-QE01	–	–
	160	6"	26444-QA01	26444-QE01	–	–

Valve with pneumatic actuator
single acting with closing spring (NC)
without solenoid valve
without position indicator

ISO-KF	10	3/8"	–	26420-KE11	–	–
	16	5/8"	26424-KA11	26424-KE11	26524-KA11	26524-KE11
	25	1"	26428-KA11	26428-KE11	26528-KA11	26528-KE11
	40	1 1/2"	26432-KA11	26432-KE11	26532-KA11	26532-KE11
	50	2"	26434-KA11	26434-KE11	26534-KA11	26534-KE11
ISO-K	63	2 1/2"	26436-QA11	26436-QE11	–	–
	80	3"	26438-QA11	–	26538-QA11	–
	100	4"	26440-QA11	26440-QE11	–	–
	160	6"	26444-QA11	26444-QE11	–	–

without solenoid valve, with position indicator: 26 **21**

with solenoid valve, without position indicator: 26 **31** (specify control voltage)

with solenoid valve, with position indicator: 26 **41** (specify control voltage)

Valve with pneumatic actuator
single acting with opening spring (NO)
without solenoid valve
without position indicator

ISO-KF	10	3/8"	–	26420-KE12	–	–
	16	5/8"	26424-KA12	26424-KE12	26524-KA12	26524-KE12
	25	1"	26428-KA12	26428-KE12	26528-KA12	26528-KE12
	40	1 1/2"	26432-KA12	26432-KE12	26532-KA12	26532-KE12
	50	2"	26434-KA12	26434-KE12	26534-KA12	26534-KE12

without solenoid valve, with position indicator: 26 **22**

with solenoid valve, without position indicator: 26 **32** (specify control voltage)

with solenoid valve, with position indicator: 26 **42** (specify control voltage)

→ Further ordering information on next page →

Features

- Body material:
aluminum or stainless steel
- Angle and inline version
- Bellows
- Resistant against differential pressure
- Long lifetime

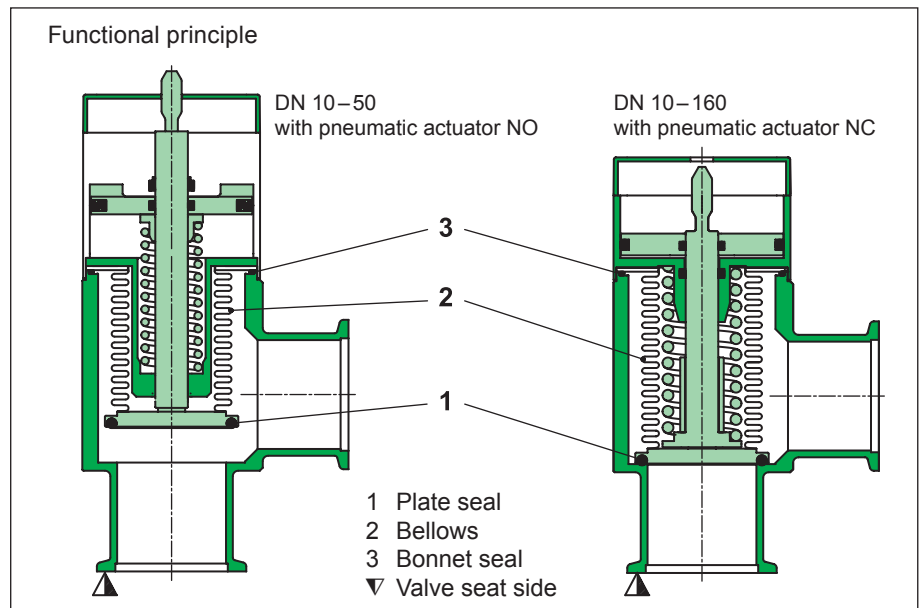

Technical data

Leak rate: valve body, valve seat	$< 1 \cdot 10^{-9}$ mbar ls ⁻¹
Pressure range, series 24 (shaft feedthrough)	
– DN 10– 50	1 · 10 ⁻⁷ mbar to 5 bar (abs)
– DN 63– 80	1 · 10 ⁻⁷ mbar to 4 bar (abs)
– DN 100– 160	1 · 10 ⁻⁷ mbar to 2 bar (abs)
– DN 200– 250	1 · 10 ⁻⁷ mbar to 1.6 bar (abs)
Pressure range, series 26 (bellows)	
– DN 10– 50	1 · 10 ⁻⁸ mbar to 5 bar (abs)
– DN 63– 80	1 · 10 ⁻⁸ mbar to 4 bar (abs)
– DN 100– 160	1 · 10 ⁻⁸ mbar to 2 bar (abs)
Differential pressure on the plate	
– In opening direction DN 10– 50	≤ 2.0 bar
DN 63– 250	≤ 1.2 bar
– In closing direction DN 10– 50	≤ 5.0 bar
DN 63– 80	≤ 4.0 bar
DN 100– 160	≤ 2.0 bar
DN 200– 250	≤ 1.6 bar
Differential pressure at opening	≤ 1 bar

Further technical data on next page →

Continued Ordering information

Valve with pneumatic actuator
double acting
without solenoid valve
without position indicator

ISO-K	DN		Ordering numbers	
	mm	inch	aluminum	stainless steel
	100	4	26440-QA14	26440-QE14
	160	6	26444-QA14	26444-QE14

without solenoid valve, with position indicator: 264 . . -Q . 24
 with solenoid valve, without position indicator: 264 . . -Q . 34 (specify control voltage)
 with solenoid valve, with position indicator: 264 . . -Q . 44 (specify control voltage)

Valve with electromagnetic actuator See pages 190–191



Continued Technical data

Cycles until first service

- DN 10– 80
- DN 100–160, series 24
- DN 100–160, series 26
- DN 200–250

with manual actuator	with closing/ opening spring	double acting
10 000	3 million	–
10 000	1 million	2 million
10 000	1 million ³⁾	1 million ³⁾
–	–	1 million ¹⁾³⁾

Temperature²⁾

- Valve body
- Manual and pneumatic actuator
- Solenoid valve, position indicator
- DN 10– 80
- DN 100–160

≤ 150 °C
≤ 120 °C
≤ 80 °C
≤ 50 °C

Material

- Valve body
 - aluminum DN 16– 63 EN AW-6060 (3.3206), -6061 (3.3211), -6063 (3.3206), -6082 (3.2315)
 - stainless steel DN 80–160 EN AC-42000
 - DN 16–160 AISI 304 (1.4301), AISI 316L (1.4404)
 - DN 200–250 AISI 321 (1.4541), AISI 304 (1.4301)
- Plate DN 16–160 AISI 316L (1.4404, 1.4435)
- DN 200–250 AISI 304 (1.4301)
- Bellows AISI 316L (1.4404, 1.4435), AISI 316 Ti (1.4571)

Seal: bonnet, plate

FKM (Viton®)

Feedthrough

- Series 24
- Series 26

shaft feedthrough
bellows

Mounting position

any

Solenoid valve

- DN 10– 80
- DN 100–160

24 VDC, 2.5 W (others on request)
24 VDC, 1.0 W (others on request)

¹⁾ Reduced lifetime with venting applications

²⁾ Maximum values: depending on operating conditions and sealing materials

³⁾ Tested at room temperature under clean and static conditions

Position indicator: contact rating

- Voltage
- Current

DN 10–160: DN 200–250:
5–50 VAC/DC ≤ 50 VAC/DC
5–100 mA ≤ 1.2 A

Valve position indication

visual (mechanical)

Angle valves

DN (nominal I.D.)			Valve with manual actuator					Valve with pneumatic actuator, single acting with closing spring (NC)								
			Turns per stroke	Weight		Compressed air min. – max. overpressure	Volume of pneumatic actuator	Closing time	Weight							
Conductance (molecular flow)	Aluminum body	Stainless steel body		Aluminum body	Stainless steel body											
mm	inch	ls ⁻¹	n	kg	lbs	kg	lbs	bar	psi	l	ft ³	s	kg	lbs	kg	lbs
10	¾	3	3.6	–	–	0.26	0.57	4–8	58–116	0.004	0.0001	0.10	–	–	0.34	0.75
16	5/8	5	3.6	0.20	0.44	0.26	0.57	4–8	58–116	0.004	0.0001	0.10	0.28	0.62	0.34	0.75
25	1	14	3.8	0.27	0.60	0.34	0.75	4–8	58–116	0.011	0.0004	0.20	0.41	0.90	0.51	1.12
40	1½	45	4.5	0.60	1.32	0.75	1.65	4–8	58–116	0.035	0.0012	0.55	0.97	2.14	1.13	2.49
50	2	80	4.8	0.94	2.07	1.10	2.43	4–8	58–116	0.047	0.0017	0.65	1.45	3.20	1.61	3.55
63	2½	160	6.6	2.90	6.39	1.70	3.75	4–8	58–116	0.112	0.0040	0.70	2.90	6.39	1.70	3.75
80	3	200	6.6	3.10	6.83	3.39	7.47	4–8	58–116	0.112	0.0040	0.70	3.10	6.83	–	–
100	4	440	11	5.79	12.76	4.85	10.69	4.5–7	65–102	0.330	0.0117	1	10	22	10	22
160	6	1000	11	8.83	19.47	7.35	16.20	4.5–7	65–102	0.650	0.0230	2	14	31	14	31

Angle valves

DN (nominal I. D.)			Conductance (molecular flow)	Valve with pneumatic actuator, single acting with opening spring (NO)						
				Compressed air min. – max. overpressure		Volume of pneumatic actuator		Closing time	Weight	
mm	inch	ls ⁻¹		bar	psi	l	ft ³		s	kg
10	3/8	3		4–8	58–116	0.004	0.0001	0.10	0.40	0.88
16	5/8	5		4–8	58–116	0.004	0.0001	0.10	0.40	0.88
25	1	14		4–8	58–116	0.011	0.0004	0.15	0.60	1.32
40	1 1/2	45		4–8	58–116	0.035	0.0012	0.20	1.36	3
50	2	80		4–8	58–116	0.047	0.0017	0.25	2.10	4.63

DN (nominal I. D.)			Conductance (molecular flow)	Valve with pneumatic actuator, double acting						
				Compressed air min. – max. overpressure		Volume of pneumatic actuator		Closing time	Weight	
mm	inch	ls ⁻¹		bar	psi	l	ft ³		s	kg
100	4	440		4.5–7	65–102	0.330	0.0117	1	7.38	16.27
160	6	1000		4.5–7	65–102	0.380	0.0134	2	12.54	27.65
200	8	2000		5–7	73–102	3.100	0.1095	2	21	46.30
250	10	3100		5–7	73–102	3.100	0.1095	2	24	52.91

Inline valves

DN (nominal I. D.)			Conductance (molecular flow)	Valve with manual actuator				Valve with pneumatic actuator, single acting with closing spring (NC)									
				Turns per stroke	Weight				Compressed air min. – max. overpressure		Volume of pneumatic actuator		Closing time	Weight			
mm	inch	ls ⁻¹	n		Aluminum body		Stainless steel body		bar	psi	l	ft ³		s	Aluminum body		Stainless steel body
				kg	lbs	kg	lbs							kg	lbs	kg	lbs
16	5/8	5	3.6	0.28	0.62	0.26	0.57	4–8	58–116	0.004	0.0001	0.10	0.50	1.10	0.50	1.10	
25	1	14	3.8	0.42	0.93	1.04	2.29	4–8	58–116	0.011	0.0004	0.20	0.60	1.32	0.60	1.32	
40	1 1/2	45	4.5	1	2.20	2.45	5.40	4–8	58–116	0.035	0.0012	0.55	1.40	3.09	1.20	2.65	
50	2	80	4.8	1.61	3.55	4.71	10.38	4–8	58–116	0.047	0.0017	0.65	2.60	5.73	2.60	5.73	
80	3	200	6.6	3	6.61	–	–	4–8	58–116	0.112	0.0040	0.70	3.75	8.27	–	–	

DN (nominal I. D.)			Conductance (molecular flow)	Valve with pneumatic actuator, single acting with opening spring (NO)						
				Compressed air min. – max. overpressure		Volume of pneumatic actuator		Closing time	Weight	
mm	inch	ls ⁻¹		bar	psi	l	ft ³		s	kg
16	5/8	5		4–8	58–116	0.004	0.0001	0.10	0.45	0.99
25	1	14		4–8	58–116	0.011	0.0004	0.15	0.70	1.54
40	1 1/2	45		4–8	58–116	0.035	0.0012	0.20	1.54	3.40
50	2	80		4–8	58–116	0.047	0.0017	0.25	2.90	6.39

E

Solenoid valve

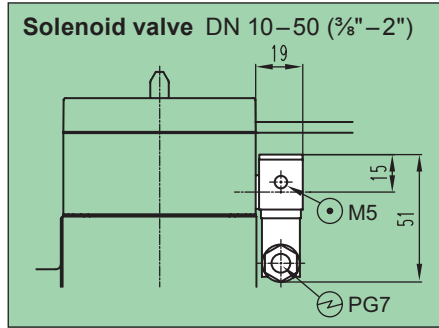

Ordering numbers: 24/26 31/41
24/26 32/42

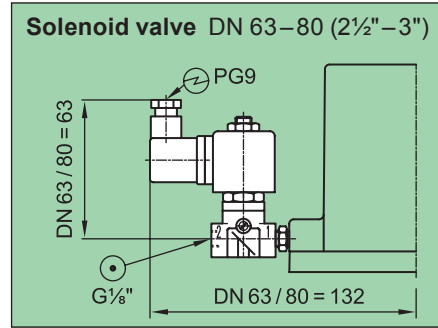

Ordering numbers: 24/26 31/41

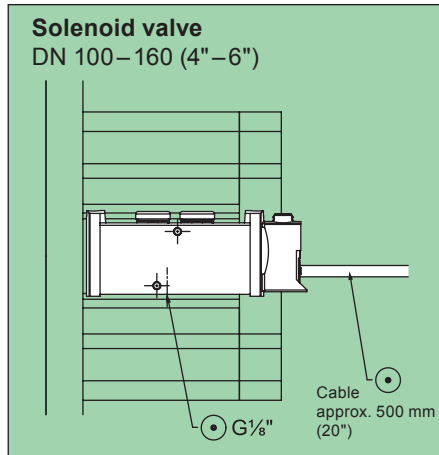

Ordering numbers: 24/26 31/41
24/26 34/44

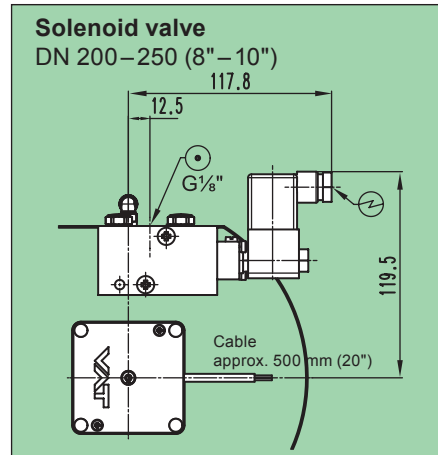

Ordering numbers: 24/26 34/44

Position indicator

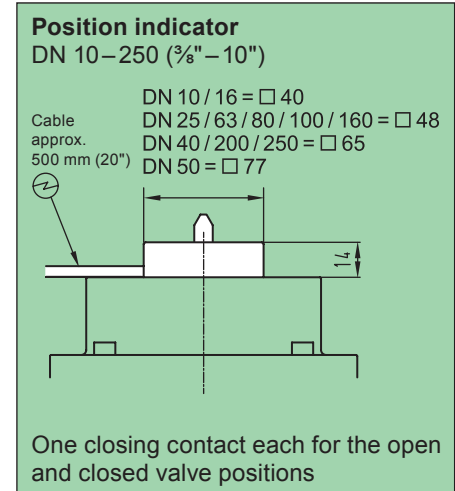

Ordering numbers: 24/26 21/41
24/26 22/42
24/26 24/44

- ⊙ Compressed air connection
- ⊕ Electrical connection

Options

Actuator

- Other solenoid valve voltage (standard: 24 VDC)
- Solenoid valve with manual emergency operation
- Position indicator bakeable to 120 °C or 200 °C
- Common connector for solenoid valve and position indicator (up to 48V only)
- Customer specified actuators

Valve

- CF flanges
- Other sealing materials
- Customer specified bodies

Ordering information for options:

Ordering No. of valve-X (e. g. 26432-KA41-X, X = pos. indicator bakeable to 200 °C)

Spare parts

- **Seals**
on request (specify fabrication number of valve)

Accessories

- **Heater**
on request (specify fabrication number of valve)
- **Flange connections**
for installation of the valve: see series 31 and 32

Dimensions

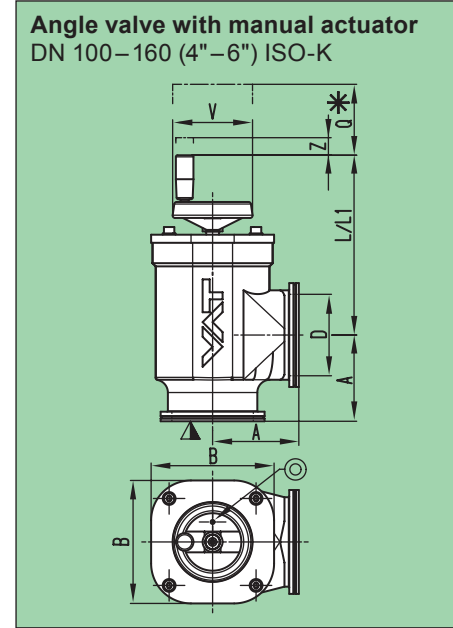
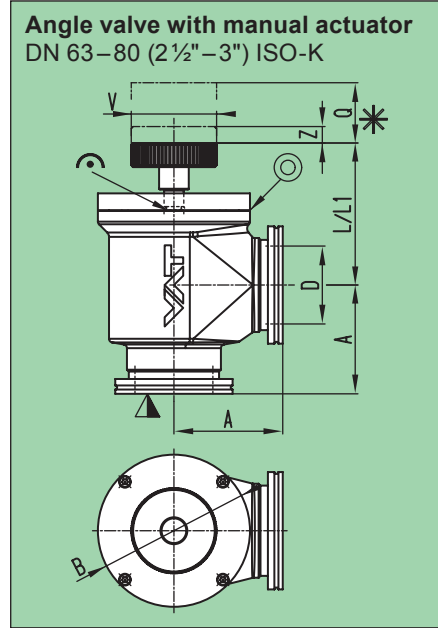
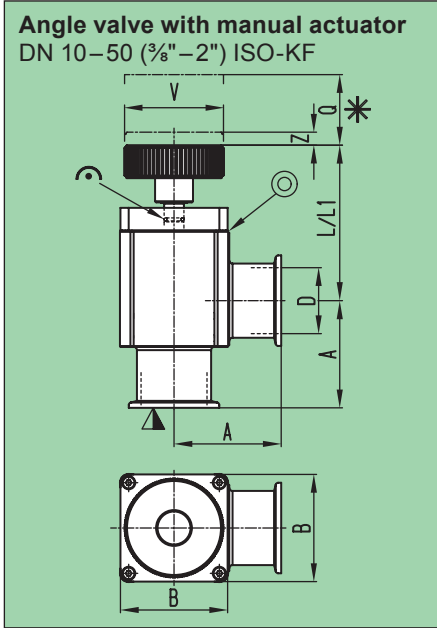

DN	mm	10	16	25	40	50	63	80	100	160
inch		3/8	5/8	1	1 1/2	2	2 1/2	3	4	6
A	mm	30	40	50	65	70	88	90	108	138
	inch	1.18	1.57	1.97	2.56	2.76	3.46	3.54	4.25	5.43
B	mm	40	40	48	65	77	123	123	154	215
	inch	1.57	1.57	1.89	2.56	3.03	4.84	4.84	6.06	8.46
D	mm	12	16	25	40	50	63	80	100	153
	inch	0.47	0.63	0.98	1.57	1.97	2.48	3.15	3.94	6.02
L	mm	-	64.90	60.90	94.30	101.10	112	111.70	225.10	240.50
	inch	-	2.56	2.40	3.71	3.98	4.41	4.40	8.86	9.47
L1	mm	67.40	67.40	64.30	97.30	104.10	111.70	-	215.60	244.70
	inch	2.65	2.65	2.53	3.83	4.10	4.40	-	8.49	9.63
Q	mm	46	46	44	73.50	85.50	105	105	170	195
	inch	1.81	1.81	1.73	2.89	3.37	4.13	4.13	6.69	7.68
V	mm	40	40	40	60	60	60	60	100	160
	inch	1.57	1.57	1.57	2.36	2.36	2.36	2.36	3.94	6.30
Z ¹⁾	mm	3.60	3.60	4.70	7.90	9.30	13.30	13.30	22	27.20
	inch	0.14	0.14	0.19	0.31	0.37	0.52	0.52	0.87	1.07

- ▽ Valve seat side
- * Required for dismantling
- ⌢ Mechanical position indication
- ⊙ Leak detection hole

L = aluminum
L1 = stainless steel

¹⁾ Gate stroke is longer due to transmission

DN 80 on request

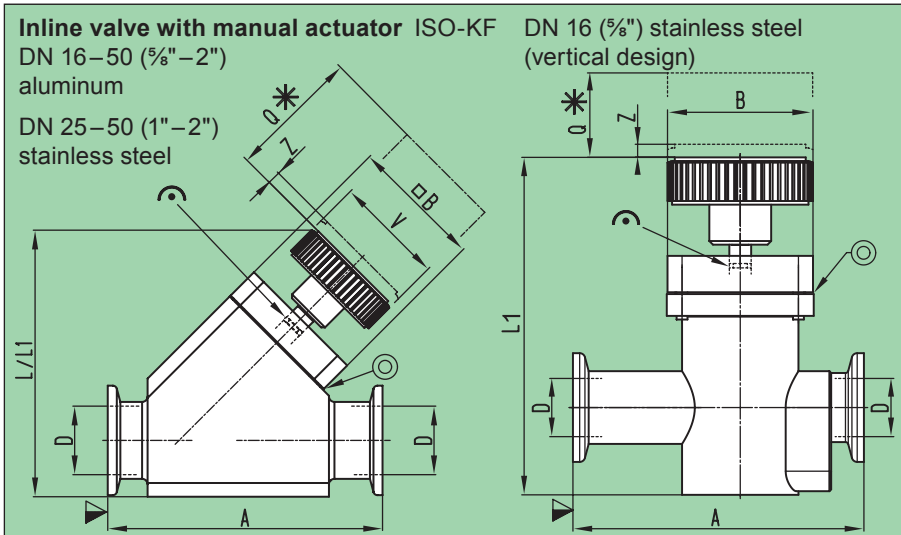

DN	mm	16	25	40	50
inch		5/8	1	1 1/2	2
A	mm	80	100	130	178
	inch	3.15	3.94	5.12	7.01
B	mm	40	48	65	77
	inch	1.57	1.89	2.56	3.03
D	mm	16	25	40	50
	inch	0.63	0.98	1.57	1.97
L	mm	90.60	97	143.50	167.20
	inch	3.57	3.82	5.65	6.58
L1	mm	92.80	105.80	152.50	175.10
	inch	3.65	4.17	6	6.89
Q	mm	46	44	73.50	85.50
	inch	1.81	1.73	2.89	3.37
V	mm	40	40	60	60
	inch	1.57	1.57	2.36	2.36
Z	mm	3.60	4.70	7.90	9.30
	inch	0.14	0.19	0.31	0.37

E

Dimensions

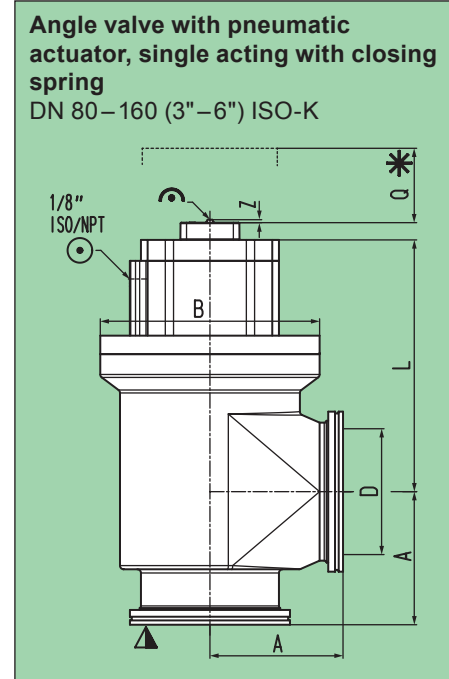
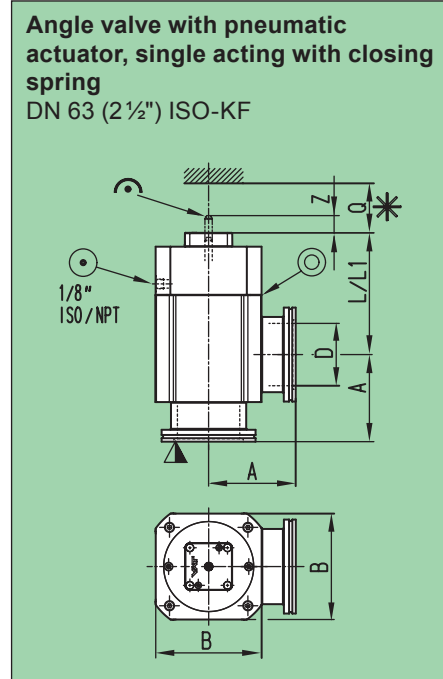
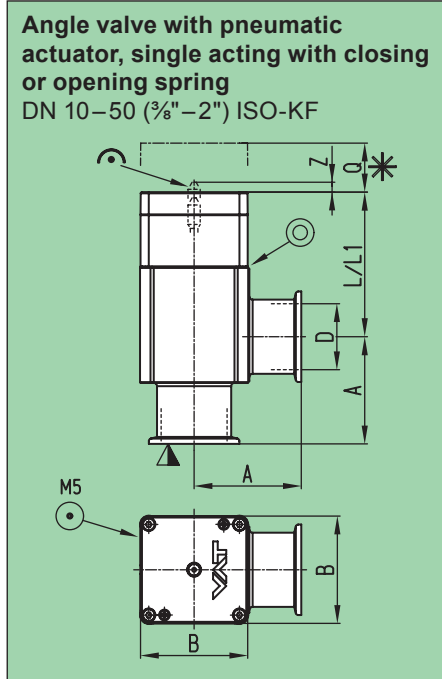

- ▽ Valve seat side
- * Required for dismantling
- ⊙ Compressed air connection
- ⤴ Mechanical position indication
- ⊙ Leak detection hole

L = aluminum
L1 = stainless steel

DN	mm inch		10 3/8	16 5/8	25 1	40 1 1/2	50 2	63 2 1/2	80 3	100 4	160 6
A	mm inch		30 1.18	40 1.57	50 1.97	65 2.56	70 2.76	88 3.46	90 3.54	108 4.25	138 5.43
B	mm inch		40 1.57	40 1.57	48 1.89	65 2.56	77 3.03	107.60 4.24	123 4.84	178 7.01	220 8.66
D	mm inch		12 0.47	16 0.63	25 0.98	40 1.57	50 1.97	63 2.48	80 3.15	102 4.02	153 6.02
L	mm inch	with closing spring	–	65.20 2.57	60.60 2.39	87.70 3.45	96 3.78	123 4.84	109 4.29	218.30 8.59	221.50 8.72
L1	mm inch		67.70 2.67	67.70 2.67	64 2.52	90.70 3.57	99 3.90	118.40 4.66	– –	211.70 8.33	228 8.98
L	mm inch	with opening spring	–	78.90 3.11	79.10 3.11	110.20 4.34	96 3.78	–	–	–	–
L1	mm inch		67.70 2.67	81.30 3.20	82.50 3.25	113.20 4.46	124 4.88	–	–	–	–
Q	mm inch		46 1.81	46 1.81	44 1.73	73.50 2.89	85.50 3.37	105 4.13	115.60 4.55	170 6.69	200 7.87
Z	mm inch		2 0.08	2 0.08	4 0.16	9.50 0.37	10.50 0.41	31.40 1.24	31.40 1.24	2.40 0.09	2.40 0.09

Dimensions

Angle valve with pneumatic actuator, double acting
DN 100–250 (4"–10") ISO-K

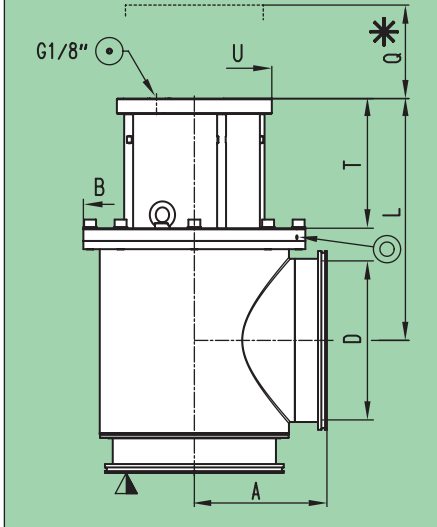

Inline valve with pneumatic actuator, single acting with closing or opening spring
DN 16–50 (5/8"–2") ISO-KF

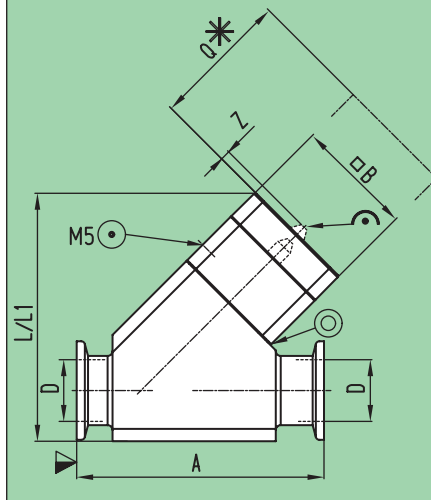

Inline valve with pneumatic actuator, single acting with closing spring
DN 80 (3") ISO-K

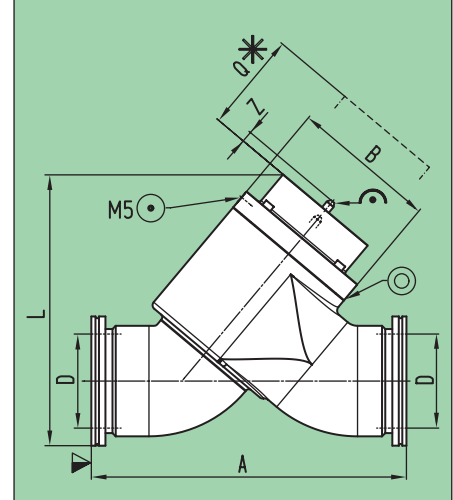

- ▽ Valve seat side
- * Required for dismantling
- ⊙ Compressed air connection
- ⤴ Mechanical position indication
- ⊙ Leak detection hole

E

L = aluminum
L1 = stainless steel

DN	mm	100	160	200	250
inch		4	6	8	10
A	mm	108	138	178	208
inch		4.25	5.43	7.01	8.19
B	mm	178	220	298	339
inch		7.01	8.66	11.73	13.35
D	mm	102	153	213	261
inch		4.02	6.02	8.39	10.28
L	mm	204.10	204.50	324.70	379.10
inch		8.04	8.05	12.78	14.93
Q	mm	170	200	258	305
inch		6.69	7.87	10.16	12.01
T	mm	77.50	84.50	174.10	204
inch		3.03	3.30	6.80	7.97
U	mm	136	136	208	208
inch		5.35	5.35	8.19	8.19

DN	mm		16	25	40	50	80
	inch		5/8	1	1 1/2	2	3
A	mm		80	100	130	178	268
inch			3.15	3.94	5.12	7.01	10.55
B	mm		40	48	65	77	123
inch			1.57	1.89	2.56	3.03	4.84
D	mm		16	25	40	50	80
inch			0.63	0.98	1.57	1.97	3.15
L	mm	with closing spring	91.50	100.30	140.90	170.10	230.50
inch			3.60	3.95	5.55	6.70	9.07
L1	mm	with opening spring	93	108.90	149.90	171.80	—
inch			3.66	4.29	5.90	6.76	—
L	mm	with opening spring	102.10	118	157.20	187.80	—
inch			4.02	4.65	6.19	7.39	—
L1	mm	with opening spring	106.70	123.20	166	189.70	—
inch			4.20	4.85	6.54	7.47	—
Q	mm		46	44	73.50	85.50	150
inch			1.81	1.73	2.89	3.37	5.91
Z	mm		2	4	9.50	10.50	31.40
inch			0.08	0.16	0.37	0.41	1.24

Main applications

For pumping and venting of HV systems where no compressed air is available



Ordering information

Valve with electromagnetic actuator
single acting with closing spring (NC)
with control electronics
with position indicator

	DN		Ordering numbers			
	mm	inch	Angle valve		Inline valve	
			aluminum	stainless steel	aluminum	stainless steel
ISO-K1F	10	3/8	–	26420-KE61	–	–
	16	5/8	26424-KA61	26424-KE61	26524-KA61	26524-KE61
	25	1	26428-KA61	26428-KE61	26528-KA61	26528-KE61
	40	1½	26432-KA61	26432-KE61	26532-KA61	26532-KE61

Technical data

Leak rate: valve body, valve seat	< 1 · 10 ⁻⁹ mbar ls ⁻¹
Pressure range	10 ⁻⁸ mbar to 2 bar (abs)
Differential pressure on the plate	2 bar
Cycles until first service	200 000
Temperature ¹⁾	
– Valve body, control electronics	≤ 50 °C
Material	
– Valve body	
– aluminum	EN AW-6060 (3.3206), -6061 (3.3211), -6063 (3.3206), -6082 (3.2315)
– stainless steel	AISI 304 (1.4301, 1.4305)
Seal: bonnet, plate	FKM (Viton®)
Feedthrough	bellows
Mounting position	any
Mains voltage	100–115 VAC / 200–240 VAC, 50–60 Hz
Starting power / holding power	700 W / 10 W
Closing or opening time	0.2 s
Operating frequency	max. 15 min ⁻¹ at 20 °C
Conductance (molecular flow): DN 10/16/25/40	3 ls ⁻¹ / 5 ls ⁻¹ / 14 ls ⁻¹ / 45 ls ⁻¹
Weight: angle valve, stainless steel	
DN 10/16/25/40	1.3/1.3/1.5/2.0 kg (2.9/2.9/3.3/4.4 lbs)

¹⁾ Maximum values: depending on operating conditions and sealing materials

Features

- Body material:
aluminum or stainless steel
- Angle and inline version
- Best conductance in its class
- Resistant against differential pressure
- Long lifetime

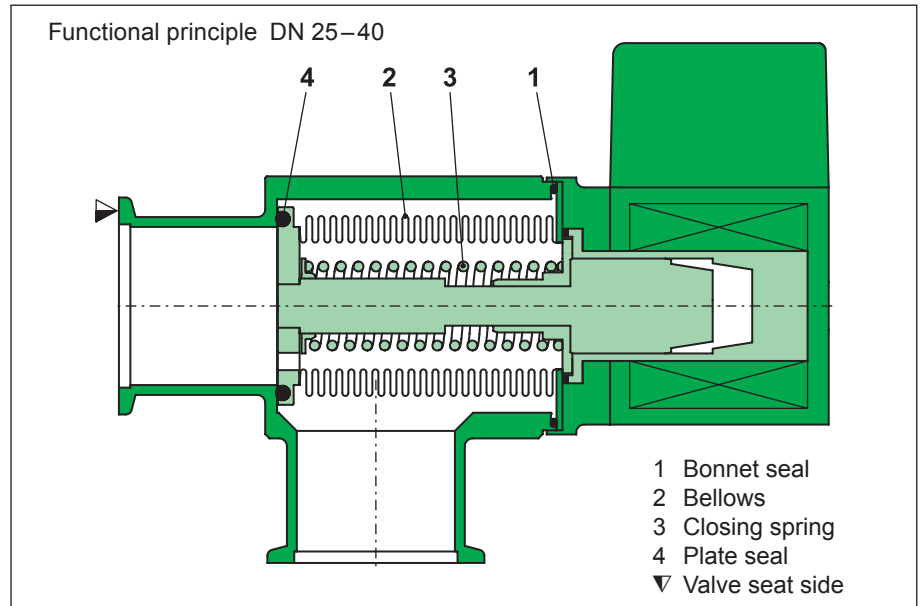

Dimensions

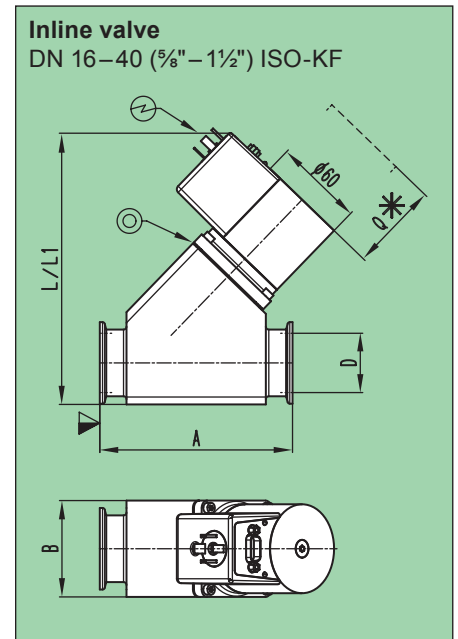
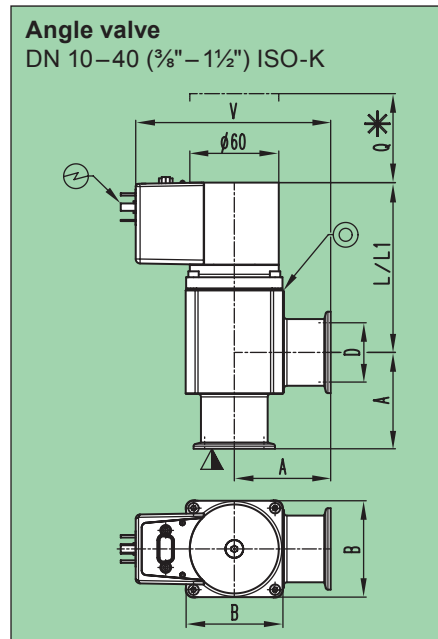

- ▽ Valve seat side
- * Required for dismantling
- ⊕ Control electronics connection
- ⊙ Leak detection hole

DN	mm	10	16	25	40
inch		3/8	5/8	1	1 1/2
A	mm	30	40	50	65
	inch	1.18	1.57	1.97	2.56
B	mm	40	40	48	65
	inch	1.57	1.57	1.89	2.56
D	mm	10	16	25	40
	inch	0.39	0.63	0.98	1.57
L	mm	–	100	93	114
	inch	–	3.94	3.66	4.49
L1	mm	102.50	102.50	103.40	117
	inch	4.04	4.04	4.07	4.61
Q	mm	46	46	44	73.50
	inch	1.81	1.81	1.73	2.89
V	mm	96.50	106.50	116.50	131.50
	inch	3.80	4.20	4.59	5.18

DN	mm	16	25	40
inch		5/8	1	1 1/2
A	mm	80	100	130
	inch	3.15	3.94	5.12
B	mm	40	48	65
	inch	1.57	1.89	2.56
D	mm	16	25	40
	inch	0.63	0.98	1.57
L	mm	148	153	183
	inch	5.83	6.02	7.20
L1	mm	149.5	161	192
	inch	5.89	6.34	7.56
Q	mm	46	44	73.50
	inch	1.81	1.73	2.89

L = aluminum
L1 = stainless steel