

USERS MANUAL

Strainer	zSTRA	Fig. 821, 823	Edition: 07/2016 Date: 01.07.2016
-----------------	--------------	----------------------	--

CONTENTS

1. Product description
2. Requirement for maintenance staff
3. Transport and storage
4. Function
5. Application
6. Assembly
7. Maintenance
8. Service and repair
9. Reasons of operating disturbances and remedy
10. Valve service discontinuity
11. Warranty terms

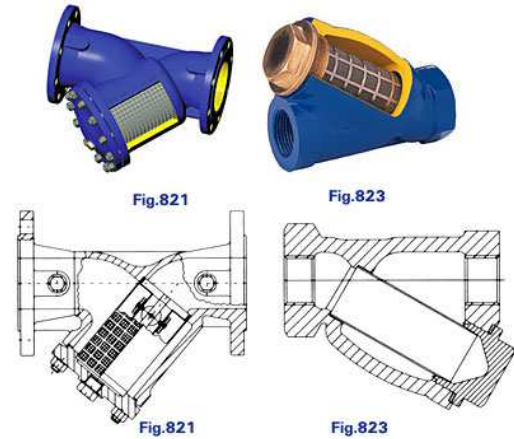

1. PRODUCT DESCRIPTION

	figure 821		figure 823
	ends flange form Y-type		ends threaded form Y-type

Y strainers - filters are provided with casted marking according to requirements of PN-EN19 standard. The marking facilitates technical identification and contains:

- diameter nominal DN (mm),
- pressure nominal PN (bar),
- body and cover material marking,
- arrow indicating medium flow direction,
- manufacturer marking,
- heat number,
- CE marking, for valves subjected 2014/68/UE directive. CE marking starts from DN32

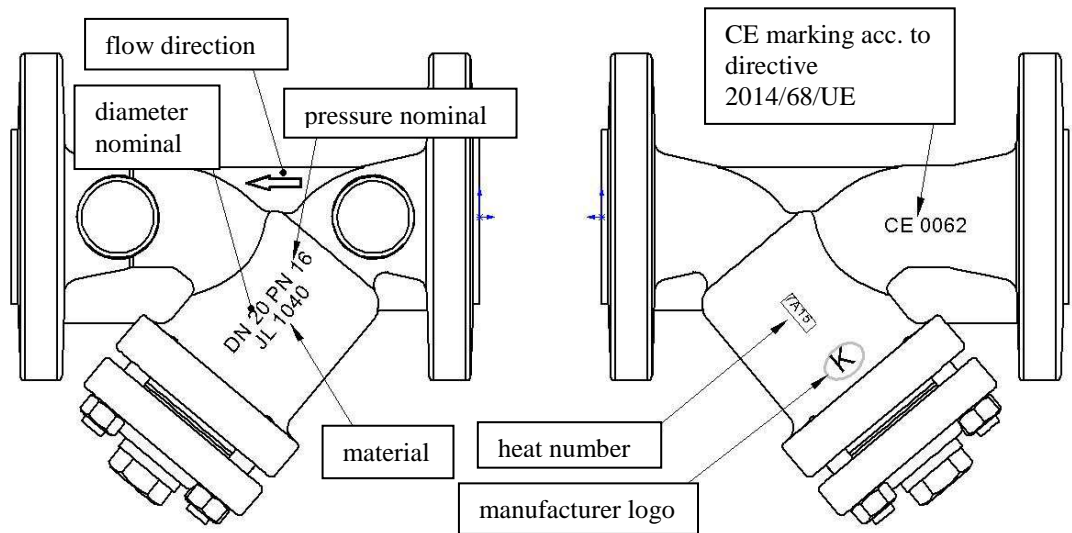

2. REQUIREMENTS FOR MAINTENANCE STAFF

The staff assigned to assembly, operating and maintenance tasks should be qualified to carry out such jobs. If during strainer operation heat parts of the strainer, for example cover or body could cause burn, user is obliged to protect them against touch.

3. TRANSPORT AND STORAGE

Transport and storage should be carried out at temperature from -20° to 65°C , and strainers should be protected against external forces influence and destruction of painting layer as well. The aim of painting layer is to protect the strainers against rust during transport and storage. Strainers should be kept at unpolluted rooms and they should be also protected against influence of atmospheric conditions. There should be applied drying agent or heating at damp rooms in order to prevent condensate formation. Strainer weights are given at catalogue card.

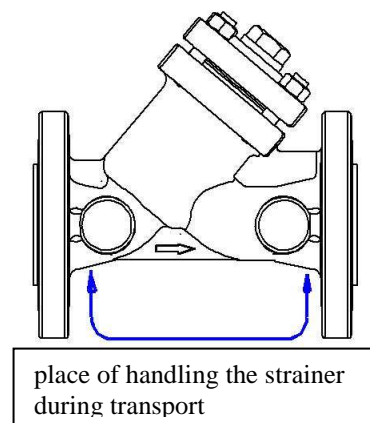
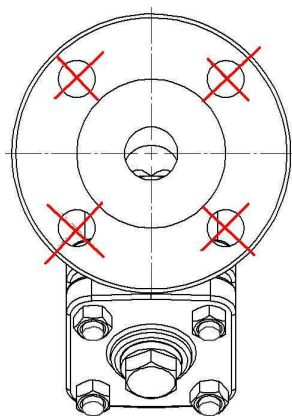

It is not allowed to fit lifting devices to connecting holes.

4. FUNCTION

Strainers – wire mesh filters are designed for cleaning flowing medium. Their task is to protect against pollutions the most sensitive plant components such as pumps, control valves, flow and heat meters. Strainer holds solid particles which dimensions exceeds screen mesh. In order to remove magnetic pollutions from the medium it is recommended to use magnetic cartridge located in the centre of filter screen.

Application range was mentioned at catalogue card. The kind of working medium makes some materials to be use or to be prohibited for use. Strainers were designed for normal working conditions. In the case that working conditions exceed these requirements (for example for aggressive or abrasive medium) user should ask manufacturer before placing an order.

When selecting the strainer for specific medium, "List of Chemical Resistance" can be helpful. It can be found at manufacturer website near catalogue cards.

Working pressure should be adapted to maximum medium temperature according to the table as below :

Acc. to EN 1092-2		Temperature [° C]					
Material	PN	from-10 up to 120	150	200	250	300	350
EN-GJL-250	6	6 bar	5,4 bar	4,8 bar	4,2 bar	3,6 bar	-----
EN-GJL-250	16	16 bar	14,4 bar	12,8 bar	11,2 bar	9,6 bar	-----
EN-GJS-400-18 LT	16	16 bar	15,5 bar	14,7 bar	13,9 bar	12,8 bar	11,2 bar
EN-GJS-400-18 LT	25	25 bar	24,3 bar	23 bar	21,8 bar	20 bar	17,5 bar

Acc. to EN 1092-1		Temperature [° C]								
Material	PN	from -60 up to -10	from -10 up to 120	100	150	200	250	300	350	400
GP240GH	40	30 bar	40 bar	37,1 bar	35,2 bar	33,3 bar	30,4 bar	27,6 bar	27,5 bar	23,8 bar



Plant designer is responsible for strainer selection suitable for working conditions.

5. APPLICATION

- hot and cold water plants , steam, air, glycol.
- industrial technologies, power industry, heat industry, HVAC plants

6. ASSEMBLY

During the assembly of strainers following rules should be observed:

- to evaluate before an assembly if the strainers were not damaged during the transport or storage
- to make sure that applied strainers are suitable for working conditions and medium used in the plant
- to take off dust caps if the strainers are provided with them

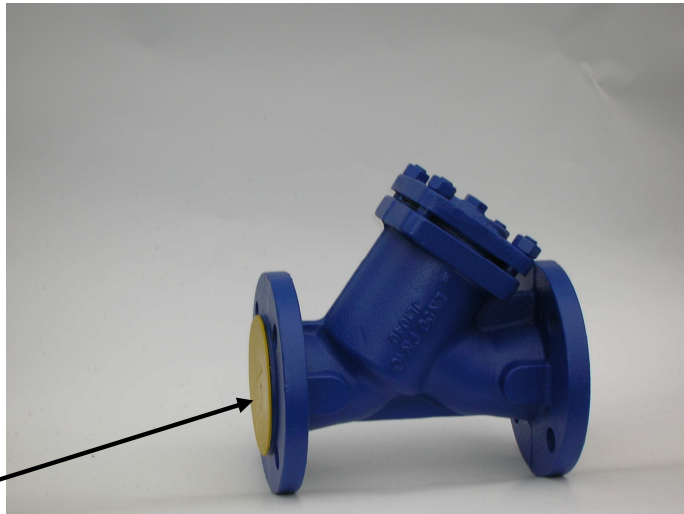

dust cap

- check if strainer body is free of solid particles
- steam pipelines should be fitted in such a way to avoid condensate collection
- to protect the strainers during welding jobs against splinters and used plastics against excessive temperature



Pipeline where the strainers are fitted should be conducted and assembled in such a way that the strainer body is not subjected to bending moment and stretching forces.

Bolted joints on the pipeline must not cause additional stress resulted from excessive tightening, and fastener materials must comply with working conditions of the plant.



To assembly the strainer in such a way that flow direction comply with an arrow placed on the body.

- strainer body throat with a screen must be put downwards in order to prevent pollution return to the pipeline,

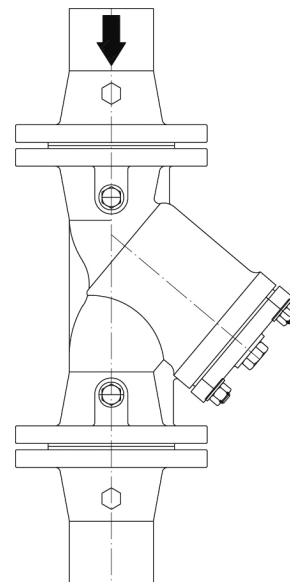
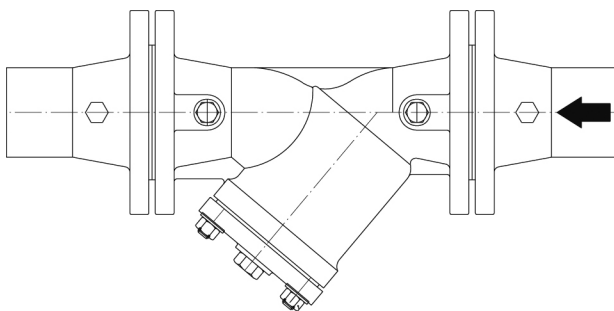

- in the case of water hammer risk caused by condensate formation, strainer body throat should be assembled in horizontal position,

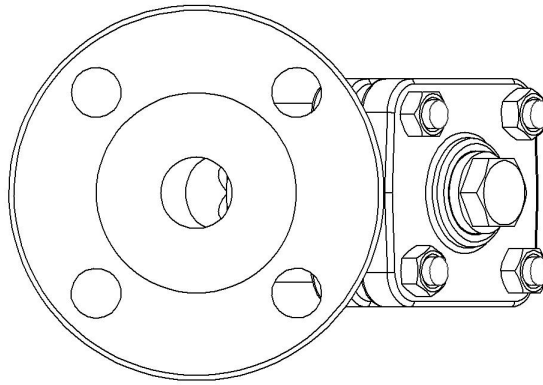

- plant designer should ensure enough space to take screen out of strainer body for cleaning,
- use expansion pipe joints in order to reduce influence of pipeline thermal expansion,
- before plant startup, especially after repairs carried out, flash out the pipeline

7. MAINTENANCE

During maintenance following rules should be observed:

- startup process – sudden changes of pressure and temperature should be avoided when starting the plant,
- strainers – wire mesh filters do not contain moving parts and do not require any maintenance jobs with exception of screen cleaning,
- strainer screens require regular cleaning – screen cleaning intervals should be established by user depending on the pollution grade of the medium,



Before taking up any service jobs make sure that medium supply to the pipeline was cut off, pressure was decreased to ambient pressure, medium was removed from the pipeline and plant was cooled down.

- cleaning or replacement the screen is possible when body – cover bolt nuts are unscrewed and screen is taken out of the strainer – remove screen impurities by strong water stream without using metal tools,
- some part of impurities can be removed by unscrewing the plug from the cover if strainer is provided with plug
- before strainer reassembly remember to replace body – cover gasket.



Precautions should be taken when touching gasket between body and strainer cover. The gasket contains stainless steel stripe that may cause injury,

- tighten hexagon nuts of cover bolts evenly and crosswise by torque wrench.

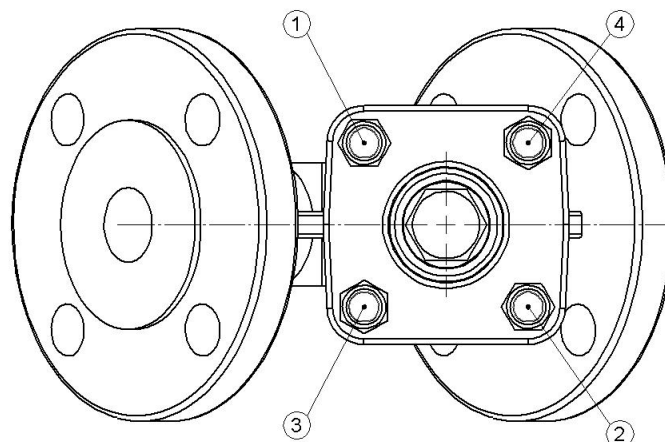

Tighten sequence of body – cover bolt nuts



In order to assure safety performance, each strainer (especially rarely used) should be surveyed on regular basis. Inspection frequency should be laid down by user, but not less than one time per month.

8. SERVICE AND REPAIR

All service and repair jobs should be carried out by authorized staff using suitable tools and original spare parts. Before disassembly of complete strainer from the pipeline or before service, the pipeline should be out of operation. During service and repair jobs:

- the pressure should be decreased to zero degrees and valve temperature to ambient temperature,
- personal health protectives in pursuance of existing threat should be used,
- after strainer disassembly it is necessary to replace flange connection gaskets between strainer and pipeline,
- tighten torques for body – cover bolts

Screw	Torque
M8	15-20 Nm
M10	35 -40 Nm
M12	65 – 70 Nm
M16	140 -150 Nm
M24	350-400 Nm

- before strainer re-assembly in the pipeline it is necessary to check strainer operation and tightness of all connections. Tightness test should be carried out with water pressure of 1,5 nominal pressure of the valve.

9. REASONS OF OPERATING DISTURBANCES AND REMEDY



When seeking of strainer malfunction reasons safety rules should be strictly obeyed

Fault	Possible reason	Remedy
No flow	Flange dust caps were not removed	Remove dust caps on the flanges
Poor flow	Dirty screen	Clean or replace the screen
	Clogged pipeline	Check the pipeline
Broken connecting flange	Bolts tighten unevenly	Replace the strainer with new one

10. VALVE SERVICE DISCONTINUITY

All obsolete and dismantled valves must not be disposed with household waste. ZETKAMA valves are made of materials which can be re-used and should be delivered to designated recycling centres.

11. WARRANTY TERMS

- ZETKAMA grants quality warranty with assurance for proper operation of its products, providing that assembly of them is done according to the users manual and they are operated according to technical conditions and parameters described in ZETKAMA's catalogue cards. Warranty period is 18 months starting from assembly date, however not longer than 24 months from the sales date.

- warranty claim does not cover assembly of foreign parts and design changes done by user as well as natural wear.

- immediately after detection the user should inform ZETKAMA about hidden defects of the product
- a claim should be prepared in written form.