

GLOBAL STYLE SAFETY LIMIT SWITCHES (Metal Bodied EN50041 TYPE) SN6 SERIES (SINGLE CONDUIT ENTRY)

For almost two decades SUNS has been delivering stand-alone solutions that offer value and field tested reliability to customers.

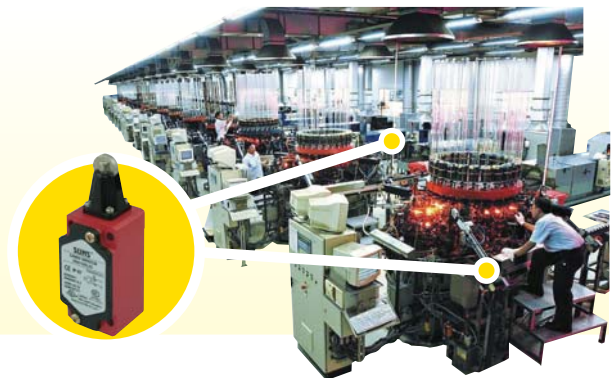

Features

- Zinc die cast body
- Increased wiring space
- Earth grounding surface on same level as switching
- Easily interchangeable contact block
- Fine adjustment of switching point via adjusting screw
- Galvanically separated contacts
- Screw terminals with self-lifting clamps for easy wiring
- Positive Opening of NC contacts
- 4 x 90° actuator positions
- Cable entry available: M20, PG13.5 and 1/2"NPT
- Conform to EN 50041 standard

Definitions of Operating Characteristics

- OF Operating Force
- RF Releasing Force
- OT Overtravel
- TT Total Travel
- PT Pretravel
- MD Movement Differential
- OP Operating Position
- PO Travel to Positive Opening



Specifications

Operating Speed	0.05mm-2m/sec
Operating Frequency	Mechanical: 120ops/min Electrical: 30 ops/min
Insulation Resistance	>100MΩ@500V DC
Contact Resistance	<25mΩ (initial value)
Rated Thermal Current	10A/600V AC (EN60947-5-1) UL/cUL Listed (E216958) AC15 A600 / DC13 Q300
Dielectric Strength	1000VAC for 1 min between current carrying parts 2500VAC for 1 min between non-current carrying parts
Service Life	Mechanically 1 x 10 ⁷ (operations) Electrically 5 x 10 ⁵ (operations)
Operating Temperature	-25~+80°C (-13~176°F) with no icing
Humidity	< 95%RH
Weight	400-480g for metal body
Degree of Protection	IP67

Selection Guide:

SN61

Body Styles

04

Head Styles

SP

Contact Block

- SP: 1NO/1NC Snap action
- SPT: 2NO/2NC Snap action
- SL: BBM 1NO/1NC Slow Action changeover
- SL1: MBB 1NO/1NC Slow Action Overlapping
- SL2: 2NC Slow Action
- SL3: 2NO Slow Action
- SL4: 3NC Slow Action
- SL5: 3NO Slow Action
- SL6: BBM 2NC/1NO Slow Action changeover
- SL7: MBB 2NC/1NO Slow Action Overlapping
- SL8: BBM 2NO/1NC Slow Action changeover
- SL9: MBB 2NO/1NC Slow Action Overlapping

C

Conduits

- A: 1/2"NPT
- B: PG13.5
- C: M20

R

- Blank
- R: with Reset

GLOBAL STYLE SAFETY LIMIT SWITCHES (Metal Bodied EN50041 TYPE) SN6 SERIES (SINGLE CONDUIT ENTRY)

Available contact blocks and travel diagrams



Plunger type
11, 12 styles

Side rotary type
04, 07, 08, 14, 18 Styles

72, 73 styles

05 styles

00, 66, 69 styles

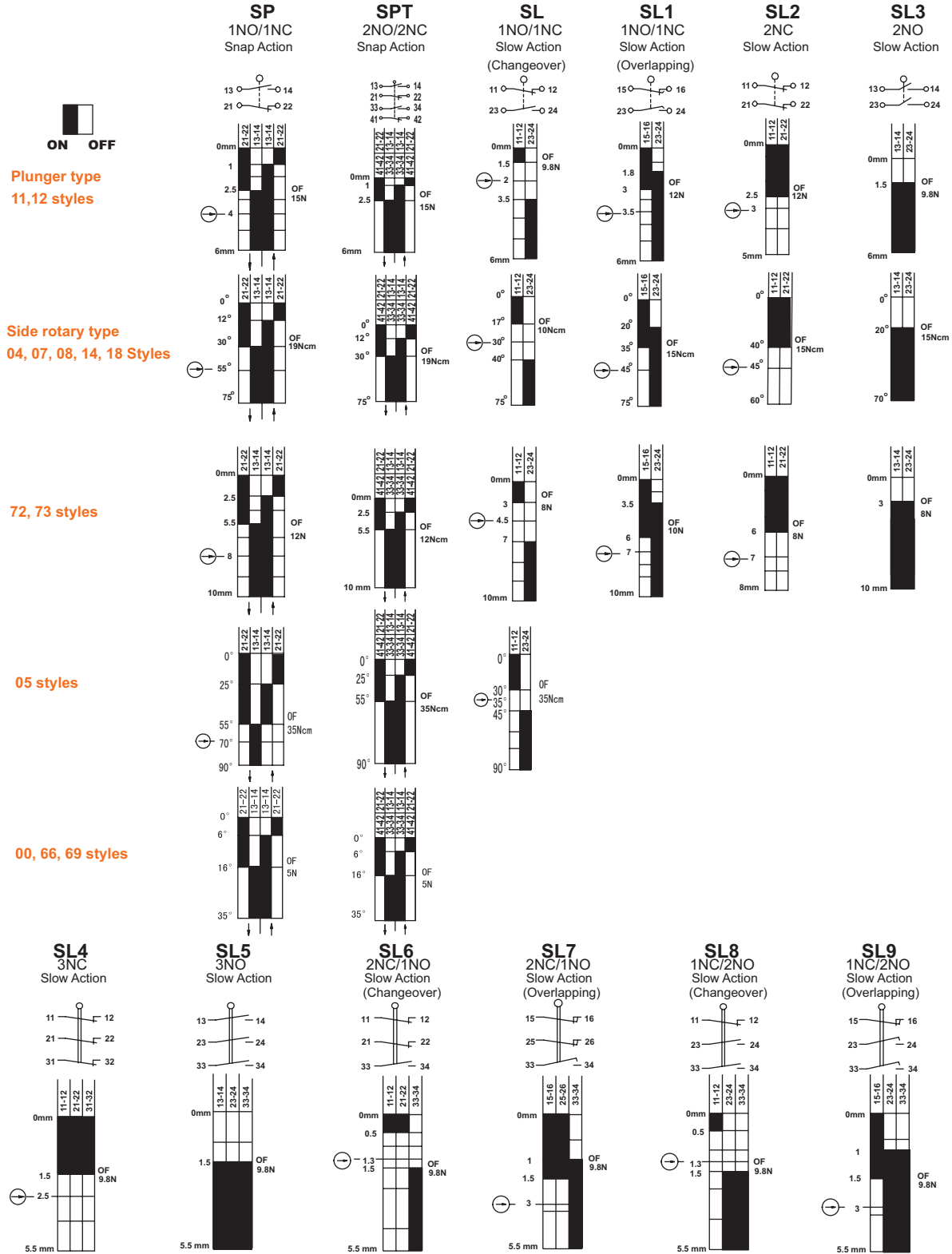

GLOBAL STYLE SAFETY LIMIT SWITCHES (Metal Bodied EN50041 TYPE) SN6 SERIES (SINGLE CONDUIT ENTRY)

SN6111

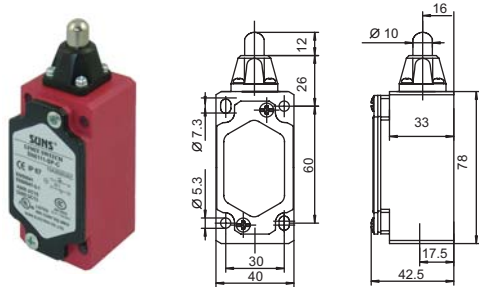

Order Code	Contact block		
SN6111-SP- _	SP	snap action	1NO+1NC
SN6111-SL- _	SL	slow action	1NO+1NC BBM
SN6111-SL1- _	SL1	slow action	1NO+1NC MBB
SN6111-SL2- _	SL2	slow action	2NC

SN6112

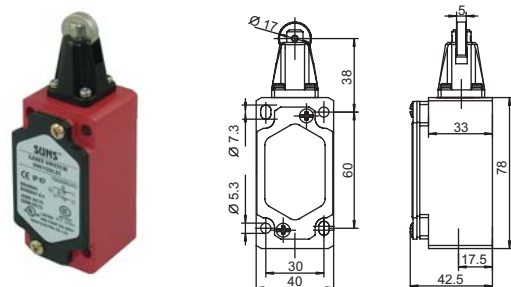

Order Code	Contact block		
SN6112-SP- _	SP	snap action	1NO+1NC
SN6112-SL- _	SL	slow action	1NO+1NC BBM
SN6112-SL1- _	SL1	slow action	1NO+1NC MBB
SN6112-SL2- _	SL2	slow action	2NC

SN6172

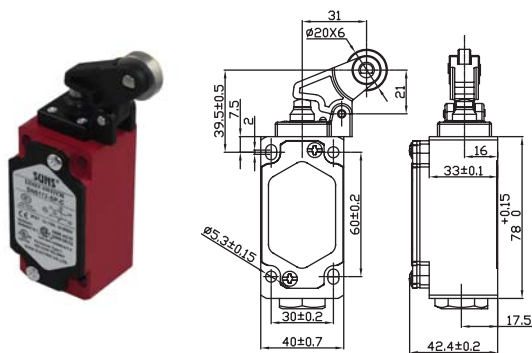

Order Code	Contact block		
SN6172-SP- _	SP	snap action	1NO+1NC
SN6172-SL- _	SL	slow action	1NO+1NC BBM
SN6172-SL1- _	SL1	slow action	1NO+1NC MBB
SN6172-SL2- _	SL2	slow action	2NC

SN6173

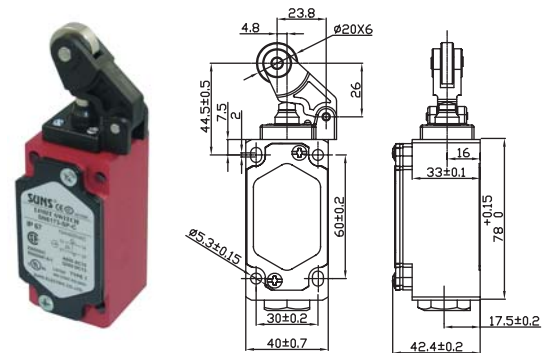

Order Code	Contact block		
SN6173-SP- _	SP	snap action	1NO+1NC
SN6173-SL- _	SL	slow action	1NO+1NC BBM
SN6173-SL1- _	SL1	slow action	1NO+1NC MBB
SN6173-SL2- _	SL2	slow action	2NC

GLOBAL STYLE SAFETY LIMIT SWITCHES (Metal Bodied EN50041 TYPE) SN6 SERIES (SINGLE CONDUIT ENTRY)

SN6104

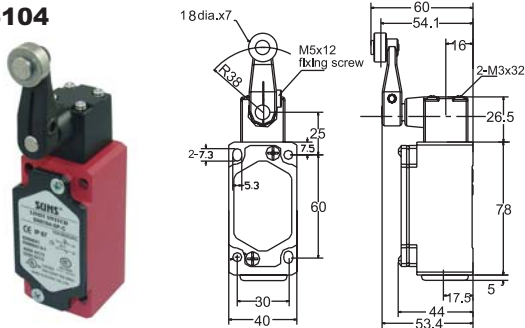

Order Code	Contact block			
SN6104-SP- _	SP	⊕	snap action	1NO+1NC
SN6104-SL- _	SL	⊕	slow action	1NO+1NC BBM
SN6104-SL1- _	SL1	⊕	slow action	1NO+1NC MBB
SN6104-SL2- _	SL2	⊕	slow action	2NC

SN6107

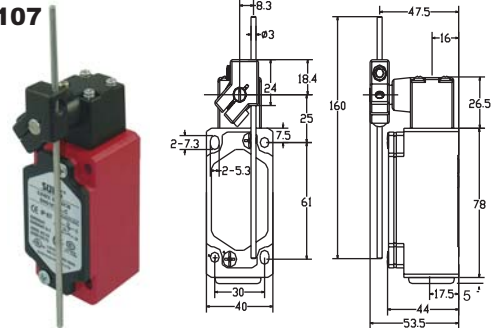

Order Code	Contact block			
SN6107-SP- _	SP	⊕	snap action	1NO+1NC
SN6107-SL- _	SL	⊕	slow action	1NO+1NC BBM
SN6107-SL1- _	SL1	⊕	slow action	1NO+1NC MBB
SN6107-SL2- _	SL2	⊕	slow action	2NC

SN6105

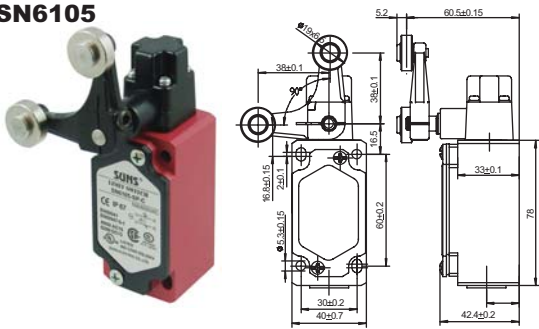

Order Code	Contact block			
SN6105-SP- _	SP	⊕	snap action	1NO+1NC
SN6105-SL- _	SL	⊕	slow action	1NO+1NC BBM

SN6108

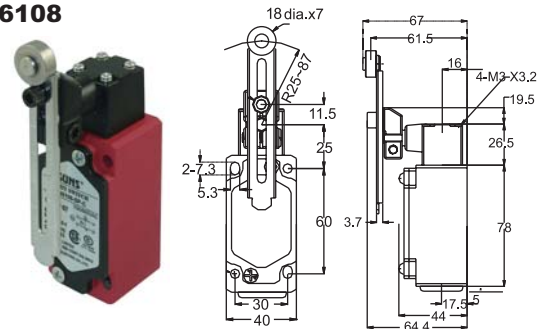

Order Code	Contact block			
SN6108-SP- _	SP	⊕	snap action	1NO+1NC
SN6108-SL- _	SL	⊕	slow action	1NO+1NC BBM
SN6108-SL1- _	SL1	⊕	slow action	1NO+1NC MBB
SN6108-SL2- _	SL2	⊕	slow action	2NC

SN6114

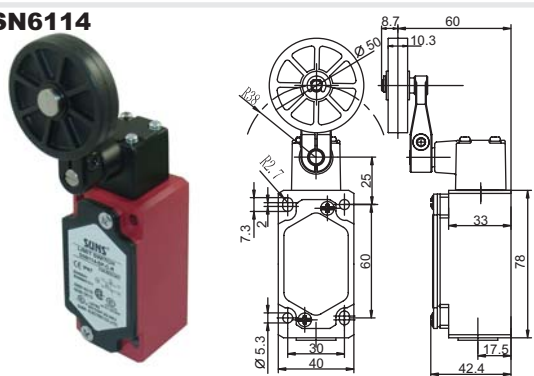

Order Code	Contact block			
SN6114-SP- _	SP	⊕	snap action	1NO+1NC
SN6114-SL- _	SL	⊕	slow action	1NO+1NC BBM
SN6114-SL1- _	SL1	⊕	slow action	1NO+1NC MBB
SN6114-SL2- _	SL2	⊕	slow action	2NC

SN6118

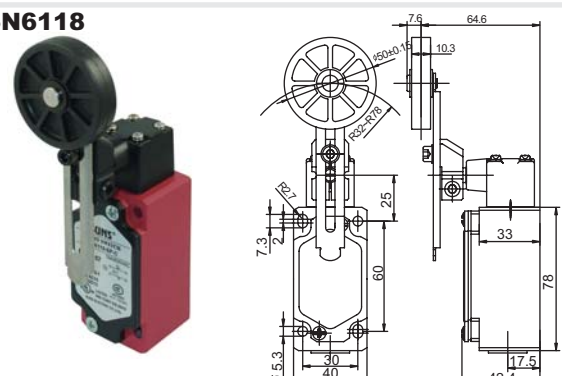

Order Code	Contact block			
SN6118-SP- _	SP	⊕	snap action	1NO+1NC
SN6118-SL- _	SL	⊕	slow action	1NO+1NC BBM
SN6118-SL1- _	SL1	⊕	slow action	1NO+1NC MBB
SN6118-SL2- _	SL2	⊕	slow action	2NC

GLOBAL STYLE SAFETY LIMIT SWITCHES (Metal Bodied EN50041 TYPE) SN6 SERIES (SINGLE CONDUIT ENTRY)

SN6104(AB)

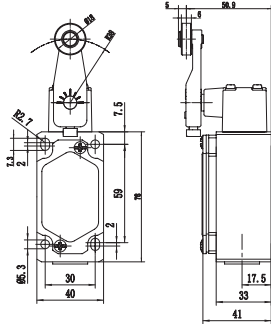

Order Code	Contact block			
SN6104-SP-_(AB)	SP	⊕	snap action	1NO+1NC
SN6104-SL-_(AB)	SL	⊕	slow action	1NO+1NC BBM
SN6104-SL1-_(AB)	SL1	⊕	slow action	1NO+1NC MBB
SN6104-SL2-_(AB)	SL2	⊕	slow action	2NC

SN6107(AB)

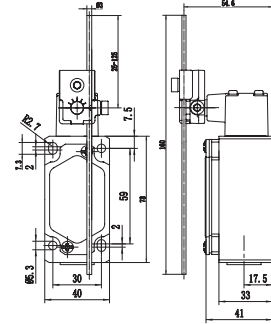

Order Code	Contact block			
SN6107-SP-_(AB)	SP	⊕	snap action	1NO+1NC
SN6107-SL-_(AB)	SL	⊕	slow action	1NO+1NC BBM
SN6107-SL1-_(AB)	SL1	⊕	slow action	1NO+1NC MBB
SN6107-SL2-_(AB)	SL2	⊕	slow action	2NC

SN6105(AB)

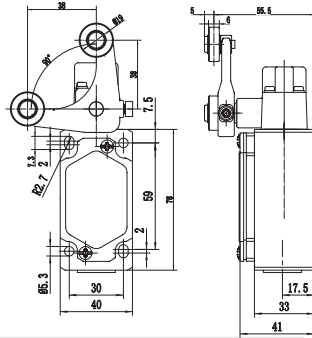

Order Code	Contact block			
SN6105-SP-_(AB)	SP	⊕	snap action	1NO+1NC
SN6105-SL-_(AB)	SL	⊕	slow action	1NO+1NC BBM

SN6108(AB)

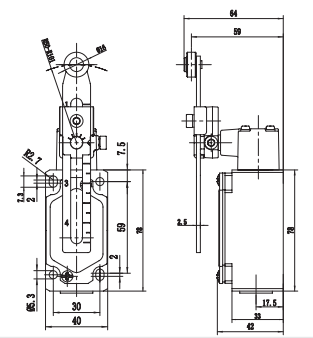

Order Code	Contact block			
SN6108-SP-_(AB)	SP	⊕	snap action	1NO+1NC
SN6108-SL-_(AB)	SL	⊕	slow action	1NO+1NC BBM
SN6108-SL1-_(AB)	SL1	⊕	slow action	1NO+1NC MBB
SN6108-SL2-_(AB)	SL2	⊕	slow action	2NC

SN6114(AB)

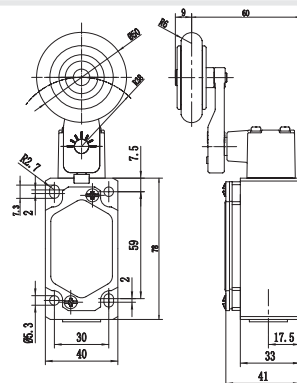

Order Code	Contact block			
SN6114-SP-_(AB)	SP	⊕	snap action	1NO+1NC
SN6114-SL-_(AB)	SL	⊕	slow action	1NO+1NC BBM
SN6114-SL1-_(AB)	SL1	⊕	slow action	1NO+1NC MBB
SN6114-SL2-_(AB)	SL2	⊕	slow action	2NC

SN6118(AB)

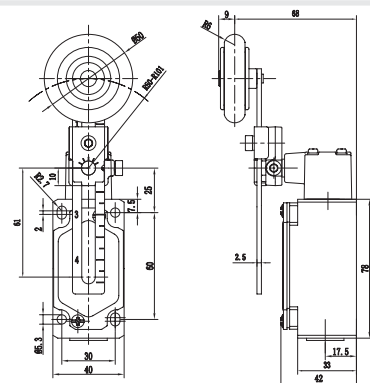

Order Code	Contact block			
SN6118-SP-_(AB)	SP	⊕	snap action	1NO+1NC
SN6118-SL-_(AB)	SL	⊕	slow action	1NO+1NC BBM
SN6118-SL1-_(AB)	SL1	⊕	slow action	1NO+1NC MBB
SN6118-SL2-_(AB)	SL2	⊕	slow action	2NC

GLOBAL STYLE SAFETY LIMIT SWITCHES (Metal Bodied EN50041 TYPE) SN6 SERIES (SINGLE CONDUIT ENTRY)

SN6100

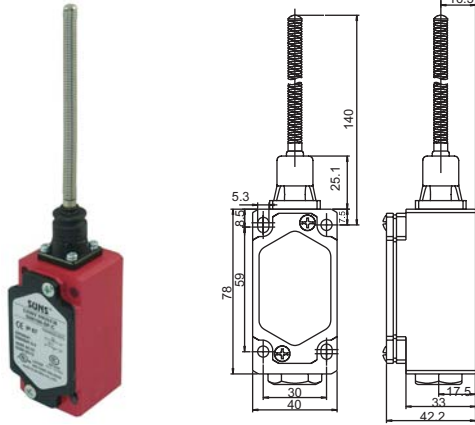

Order Code

SN6100-SP- _ SP snap action 1NO+1NC

SN6166

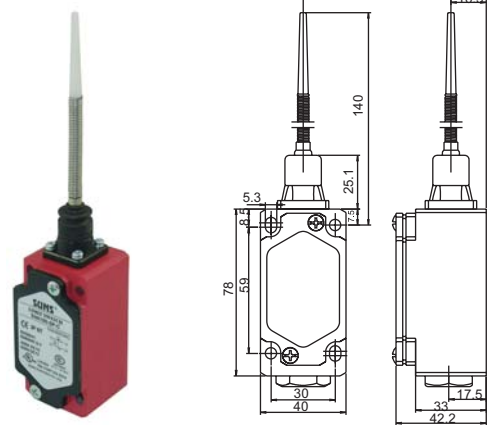

Order Code

SN6166-SP- _ SP snap action 1NO+1NC

SN6169

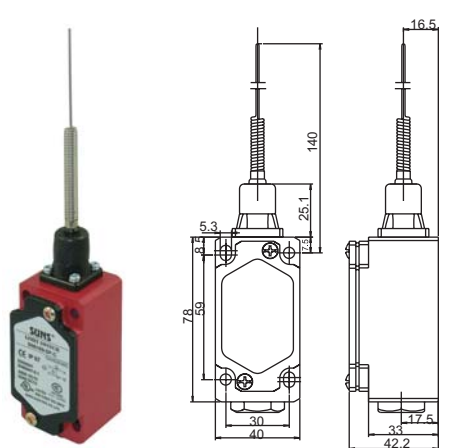

Order Code

SN6169-SP- _ SP snap action 1NO+1NC

SN6111-L

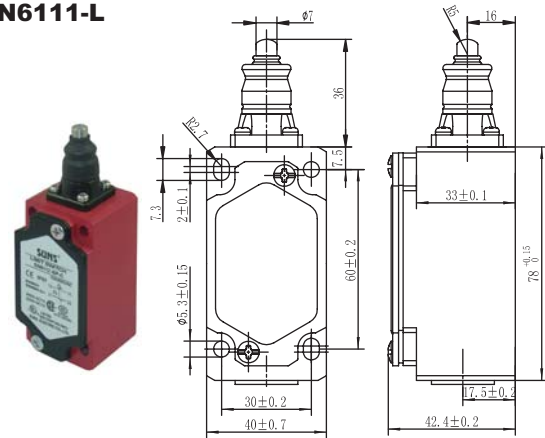

Order Code

Order Code	Contact block	Action	Configuration
SN6111-SP- _L	SP	⊕ snap action	1NO+1NC
SN6111-SL- _L	SL	⊕ slow action	1NO+1NC BBM
SN6111-SL1- _L	SL1	⊕ slow action	1NO+1NC MBB
SN6111-SL2- _L	SL2	⊕ slow action	2NC

GLOBAL STYLE SAFETY LIMIT SWITCHES (Metal Bodied EN50041 TYPE) SN6 SERIES (SINGLE CONDUIT ENTRY WITH RESET)

SN6104-R(AB)

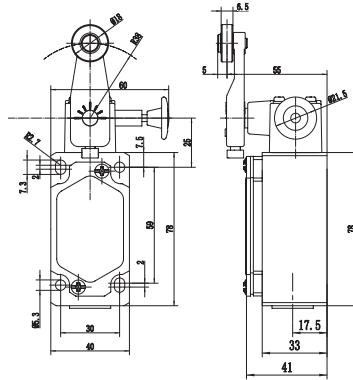

Order Code	Contact block	SP	SL	SL1	SL2
SN6104-SP- _R(AB)	SP	⊕	⊕	⊕	⊕
SN6104-SL- _R(AB)	SL	⊕	⊕	⊕	⊕
SN6104-SL1- _R(AB)	SL1	⊕	⊕	⊕	⊕
SN6104-SL2- _R(AB)	SL2	⊕	⊕	⊕	⊕

SN6107-R(AB)

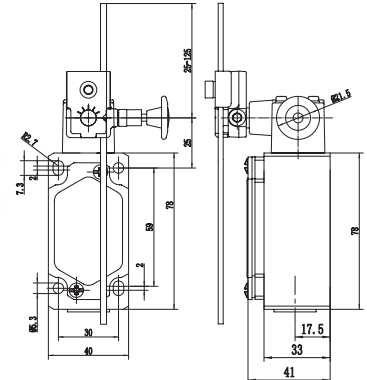

Order Code	Contact block	SP	SL	SL1	SL2
SN6107-SP- _R(AB)	SP	⊕	⊕	⊕	⊕
SN6107-SL- _R(AB)	SL	⊕	⊕	⊕	⊕
SN6107-SL1- _R(AB)	SL1	⊕	⊕	⊕	⊕
SN6107-SL2- _R(AB)	SL2	⊕	⊕	⊕	⊕

SN6108-R(AB)

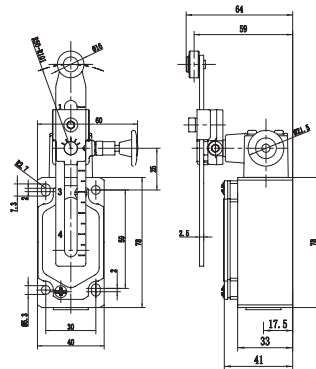

Order Code	Contact block	SP	SL	SL1	SL2
SN6108-SP- _R(AB)	SP	⊕	⊕	⊕	⊕
SN6108-SL- _R(AB)	SL	⊕	⊕	⊕	⊕
SN6108-SL1- _R(AB)	SL1	⊕	⊕	⊕	⊕
SN6108-SL2- _R(AB)	SL2	⊕	⊕	⊕	⊕

SN6118-R(AB)

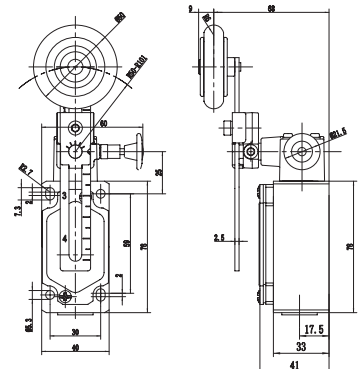

Order Code	Contact block	SP	SL	SL1	SL2
SN6118-SP- _R(AB)	SP	⊕	⊕	⊕	⊕
SN6118-SL- _R(AB)	SL	⊕	⊕	⊕	⊕
SN6118-SL1- _R(AB)	SL1	⊕	⊕	⊕	⊕
SN6118-SL2- _R(AB)	SL2	⊕	⊕	⊕	⊕

SN6114-R(AB)

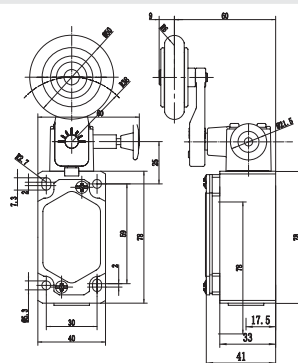

Order Code	Contact block	SP	SL	SL1	SL2
SN6114-SP- _R(AB)	SP	⊕	⊕	⊕	⊕
SN6114-SL- _R(AB)	SL	⊕	⊕	⊕	⊕
SN6114-SL1- _R(AB)	SL1	⊕	⊕	⊕	⊕
SN6114-SL2- _R(AB)	SL2	⊕	⊕	⊕	⊕

Additional Lever Heads for SN61,SN62,SND61,SN63



Cast Aluminum Lever Arms with Roller

Add '-P' suffix for nylon roller (following part numbers are with steel roller)

Arm Length in. (mm)	Roller Diameter in. (mm)	Roller Width in. (mm)	Part Number
1.38 (35)	0.75 (19)	0.25 (6.3)	H-04B1(AB)
		0.63 (16)	H-04B2(AB)
	0.63 (16)	0.25 (6.3)	H-04B3(AB)
		0.63 (16)	H-04B4(AB)
		1 (25.4)	H-04B5(AB)
1.5 (38)	0.75 (19)	0.25 (6.3)	H-04C1(AB)
		0.63 (16)	H-04C2(AB)
	0.63 (16)	0.25 (6.3)	H-04C3(AB)
		0.63 (16)	H-04C4(AB)
		1(25.4)	H-04C5(AB)
		1.97(50)	H-4C5(AB)
2 (51)	0.75 (19)	0.25 (6.3)	H-04D1(AB)
		0.63 (16)	H-04D2(AB)
	0.63 (16)	0.25 (6.3)	H-04D3(AB)
		0.63 (16)	H-04D4(AB)
		0.25 (6.3)	H-04E1(AB)
2.5 (63.5)	0.75 (19)	0.63 (16)	H-04E2(AB)
		0.25 (6.3)	H-04E3(AB)
	0.63 (16)	0.63 (16)	H-04E4(AB)
		0.25 (6.3)	H-04F1(AB)
3 (76)	0.75 (19)	0.63 (16)	H-04F2(AB)
		0.25 (6.3)	H-04F3(AB)
	0.63 16	0.25 (6.3)	H-04F3(AB)
		0.63 16	H-04F4(AB)

* Mounting hole center to roller center distance



90° Forked Cast Aluminum Lever Arms with Roller

Add '-P' suffix for nylon roller (following part numbers are with steel roller)

Arm Length in. (mm)	Roller			Part Number
	Roller Position	Diameter in. (mm)	Width in. (mm)	
1.5 (38)	Rollers on same side	0.75 (19)	0.25 (6.3)	H-05-1(AB)
		0.63 (16)	0.25 (6.3)	H-05-3(AB)
	R.H. Rollers on opposite side	0.75 (19)	0.25 (6.3)	H-05-1RH(AB)
		0.63 (16)	0.25 (6.3)	H-05-3RH(AB)
	L.H. Rollers on opposite side	0.75 (19)	0.25 (6.3)	H-05-1LH(AB)
		0.63 (16)	0.25 (6.3)	H-05-3LH(AB)

* Mounting hole center to roller center distance

Adjustable Length Lever Arm with Steel Roller

Lever Length in. (mm)	Roller Dia. in. (mm)	Roller Width in. (mm)	Part Number
Non-bendable, adjustable from 22-101mm	0.63 (16)	0.25 (6.3)	H-08-3(AB)
	0.63 (16)	0.63 (16)	H-08-4(AB)
	0.75(19)	0.25(6.3)	H-08-5(AB)
Bendable, adjustable from 22-101mm	0.63 (16)	0.25 (6.3)	H-08B-3(AB)
	0.63 (16)	0.63 (16)	H-08B-4(AB)
	0.75(19)	0.25(6.3)	H-08B-5(AB)

Adjustable Length Lever Arm with Nylon Roller

Lever Length in. (mm)	Roller Dia. in. (mm)	Roller Width in. (mm)	Part Number
Non-bendable, adjustable from 22-101mm	0.63 (16)	0.25 (6.3)	H-08-3P(AB)
	1 (25.4)	0.63 (16)	H-08-5P(AB)
	0.63 (16)	0.25 (6.3)	H-08B-3P(AB)
Bendable, adjustable from 22-101mm	1.0 (25.4)	0.63 (16)	H-08B-5P(AB)
	2 (51)	0.25 (6.3)	H-08B-6P(AB)
	0.75(19)	0.25(6.3)	H-08-7P(AB)

* Mounting hole center to roller center distance

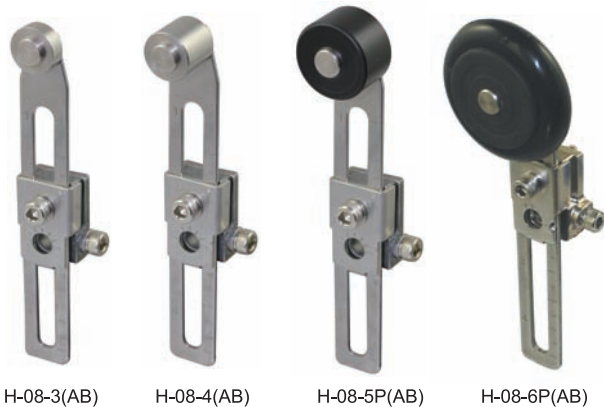

Additional Lever Heads for SN61,SN62,SND61,SN63



Rod Type Lever Arms

Description	Length in. (mm)	Part Number
Stainless Steel Rod	10 (254)	H-07-10(AB)
Spring Rod, Steel	12 (304)	H-07S-12(AB)
Spring Rod, Delrin	12 (304)	H-07P-12(AB)
Looped Delrin Rod Arm	160MM(6.3IN.)	H-06(AB)
Looped Delrin Rod Arm	228MM(9IN.)	H-09(AB)