

GENERAL DESCRIPTION

Axial piston variable displacement pumps, Series 20, are of swash plate construction with variable flow capability suitable for hydrostatic transmissions with closed circuit. The flow rate is proportional to the pump's driven speed displacement, which, in turn, is determined by the swash plate angle. The latter is infinitely adjustable between zero and maximum displacement. Flow direction is reserved by tilting the swash plate to the opposite side of the neutral or zero displacement position.

Figure 1:

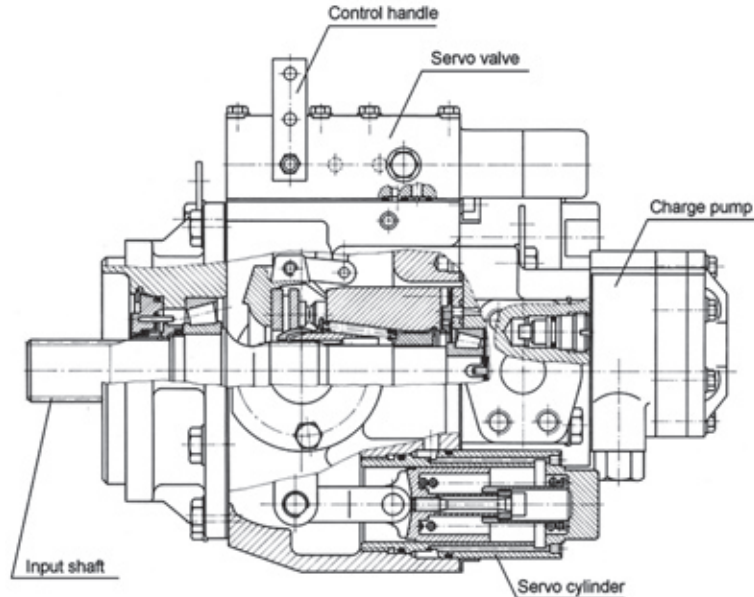

FEATURES

Axial piston variable displacement pumps, Series 20, are well - engineered and easy handle. The full - length shaft with a highly efficient tapered roller bearing arrangement offers a high loading capacity for external radial forces. Additional pumps can be built on. The hydro - mechanical servo displacement control maintains the selected swash plate position and hence pump displacement. Upon release of the control handle, the swash plate automatically returns to the null positions and the flow becomes zero. High case pressures can be achieved without leakage even at the lowest temperatures by using suitable shaft seals. The servo valve arrangement offers the facility to incorporate function regulators and remote control systems. Axial piston units are designed for easy servicing, complete dismantling and disassembly can be carried out with standard hand tools, and all components or sub - assemblies are replaceable.

Figure 2:

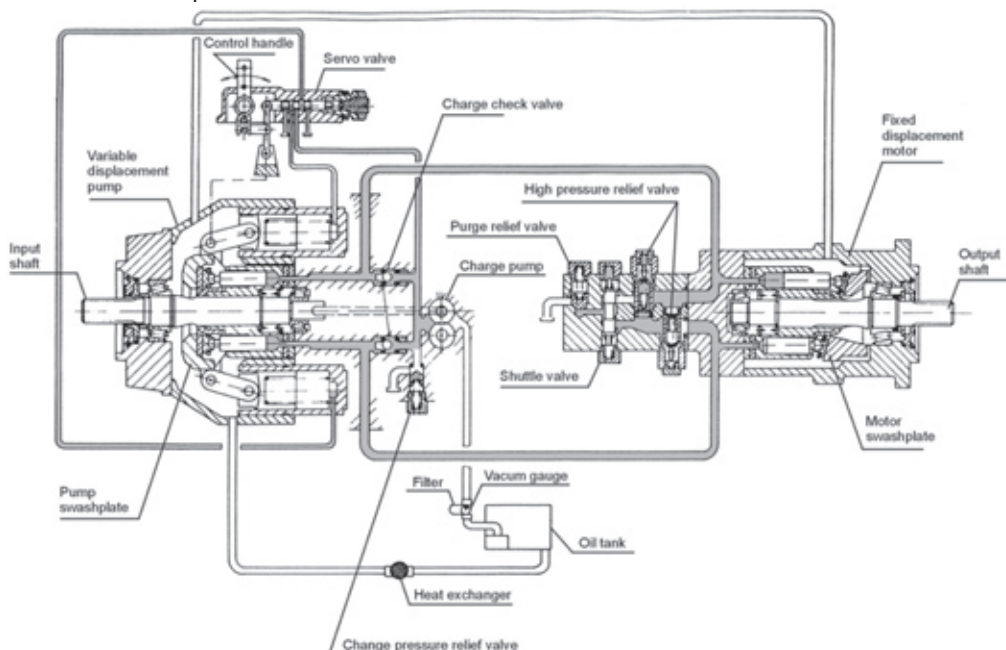
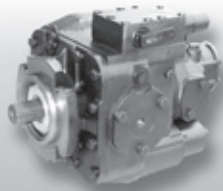

Figure 2 shows schematically the function of hydrostatic transmission using an axial piston variable displacement pump and fixed displacement motor.



TECHNICAL DATA

Table 1:

	Dimensions	Frame Size							
		PV-20	PV-21	PV-22	PV-23	PV-24	PV-25	PV-26	PV-27
Max. displacement per revolution of the variable displacement pump	cm ³	33,3	51,6	69,8	89,0	118,7	165,8	227,3	333,7
Max. flow	dm ³ min ⁻¹	119,54	159,96	196,14	230,51	278,94	348,18	429,59	557,28
Displacement per revolution of the charge pump	cm ³	12,3	12,3	18,03	18,03	18,8	32,8	32,8	65,5
Max. pressure	MPa	35							
Nominal pressure	MPa	21							
Max. pressure of control	MPa	3,5							
Charge pressure	MPa	0,8 - 2,0							
Max. pressure in case	MPa	0,25 continuous				0,5 intermittent			
Maximum speed +	min ⁻¹	3590	3100	2810	2590	2350	2100	1890	1670
Minimum speed	min ⁻¹	500							
Nominal speed	min ⁻¹	1500							
Kinematic viscosity range of working fluid	mm ² s ⁻¹	1000 12 - 600 25 - 35							
-starting									
-operating									
-optimum									
Kind of working fluid		mineral oil							
Operating temperature	°C	-40 to +50							
Max. temperature of working fluid in tank	°C	80							
Purity of working fluid	microns	10 μm							
Direction of shaft rotation		clockwise or counterclockwise							
Maximum swash plate angle	degrees	±18°							
Weight	kg	45	55	63	78	124	164	212	270

Figure 3. External drain fluid loss for frame sizes 20 – 23
Determination of nominal pump size

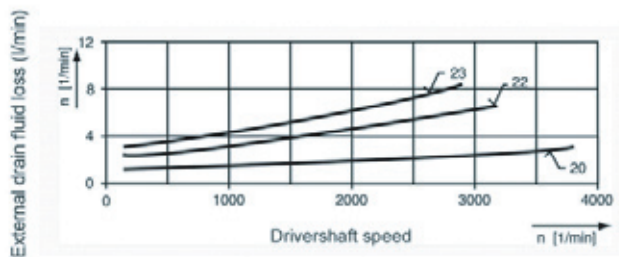

$$Q_e = \frac{V_g \cdot n \cdot \eta_v}{1000} \quad (\text{l/min})$$

$$M_e = \frac{15,9 \cdot V_g \cdot \Delta p}{100 \cdot \eta_{mh}} \quad (\text{Nm})$$

$$P_e = \frac{M_g \cdot n}{9550} = \frac{Q_e \cdot \Delta p}{600 \eta_t}$$

V_g – displacement (cm³) per revolution
 Δp – difference high and low pressure (MPa)
 n – speed (min⁻¹)
 η_v – volumetric efficiency
 η_{mh} – mechanical – hydraulic efficiency
 η_t – total efficiency

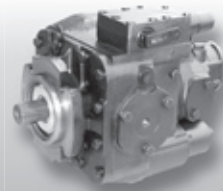

EXAMPLES OF CURVES DEPENDENCES OF EFFICIENCY, FLOW AND OUTPUT ON THE SPEED

(for operating condition of 18° swash plate angle)

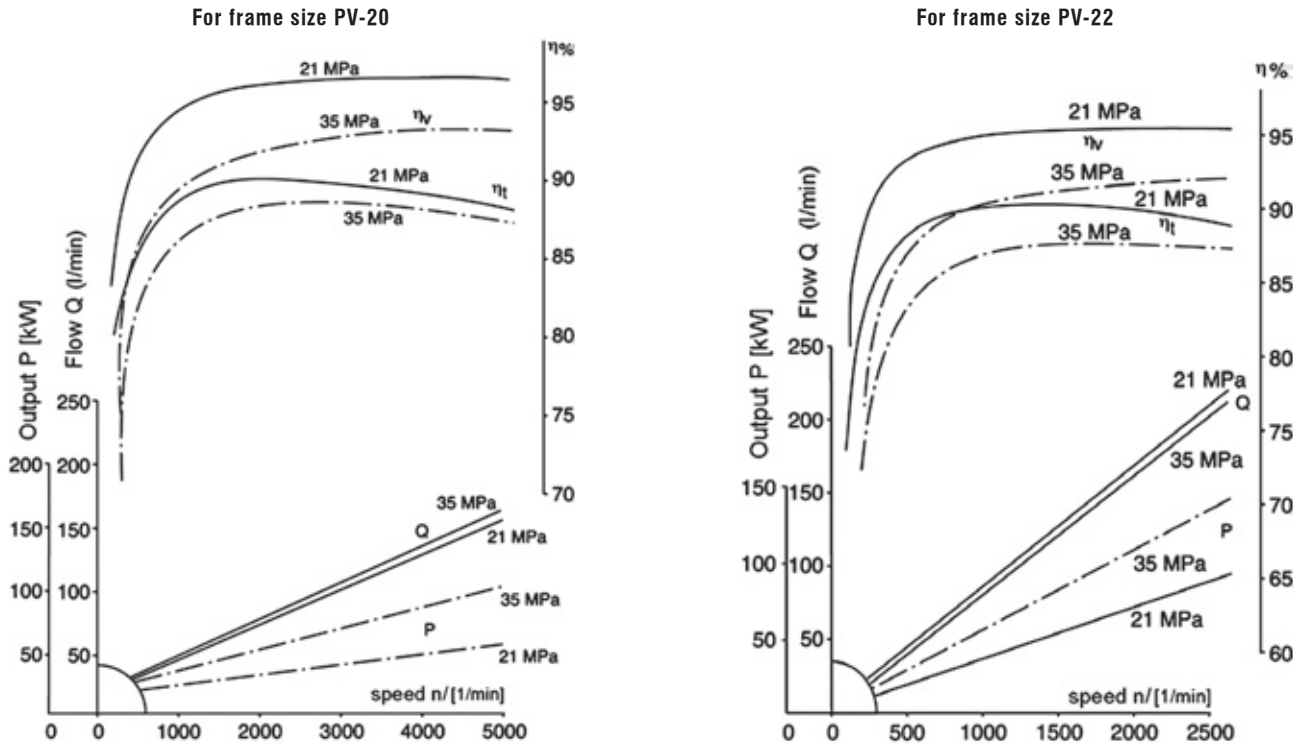

For frame size PV-23

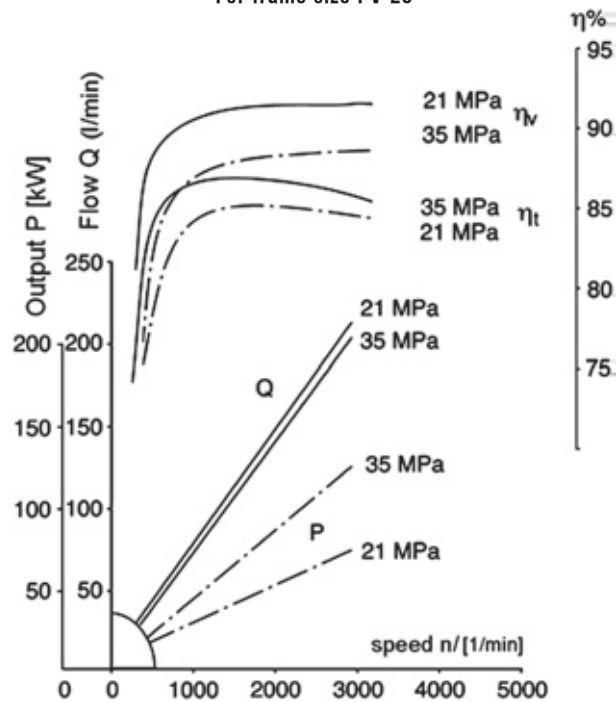

η_v - volumetric efficiency
 η_t - total efficiency

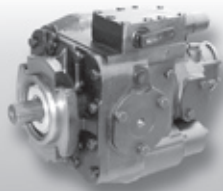

SERVO DISPLACEMENT CONTROL (LINEAR RESPONSE)

Regulated by the control handle on the servo valve the swash plate can be infinitely varied in both directions with the help of the servo system. The pump displacement resulting from any control handle position can be established using figures (5a - 5c). The angle of the control handle for stroke initiation and for the final position of the stroke can vary from unit to unit within the range of the tolerance band (Figure 5a - 5c).

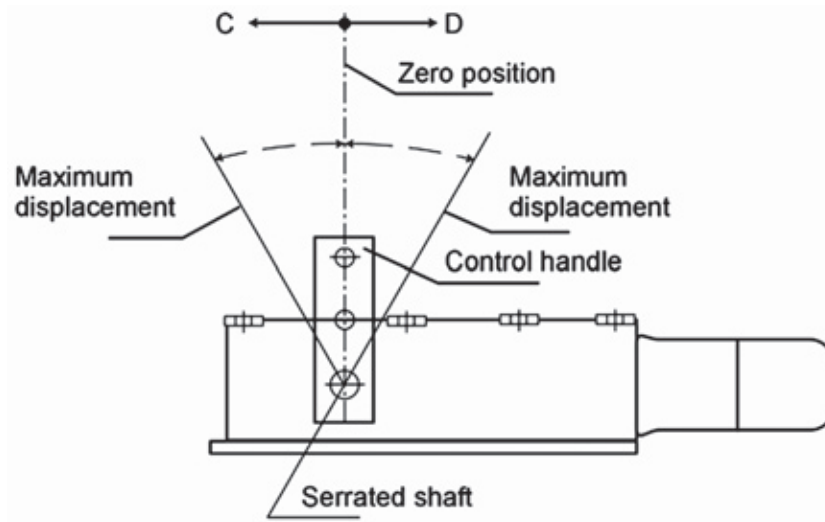

Frame size PV-20

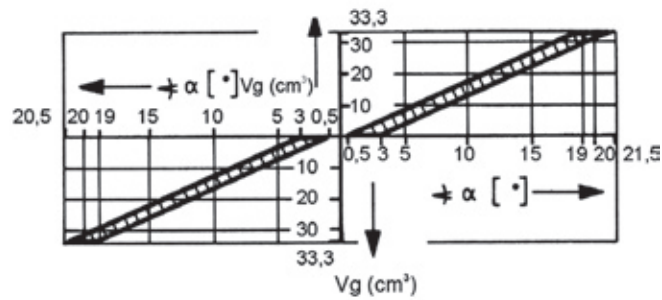

Frame size PV-22

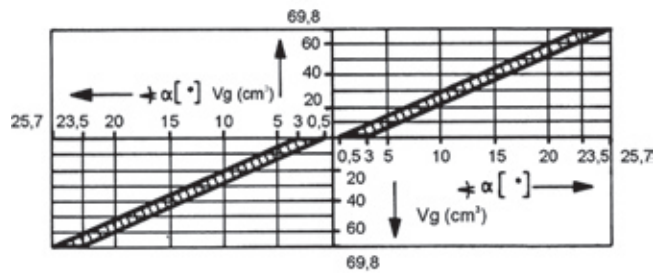

Frame size PV-23

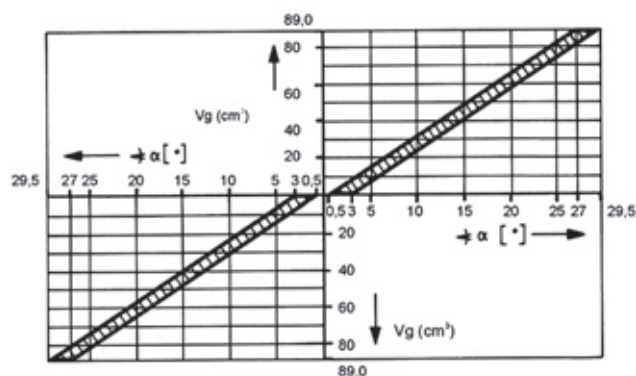

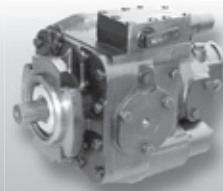

REVERSING TIME

Time for the directional change of the flow from Q_{max} across 0 to Q_{max} depending on the size of the control orifice fitted in the supply port to the servo valve (figure 7).

The values given assume movement of the control handle directly from one end position to other.

Adjustment time of handle: < minimum reversing time
 Operating pressure: 21 MPa
 Speed: 1450 min⁻¹
 Viscosity: 35 mm².s⁻¹

Schematic diagram of servovalve with alternate orifice position.

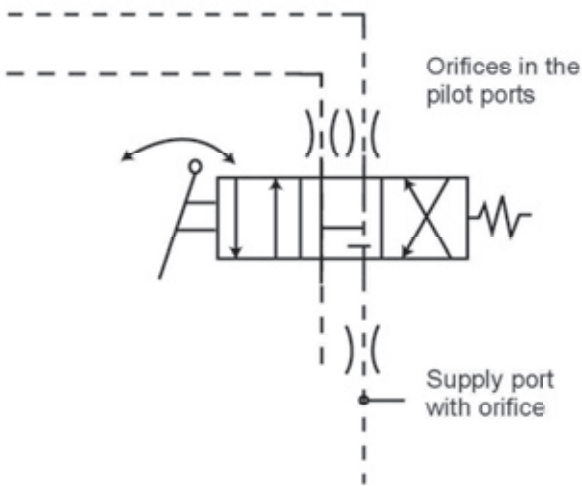

Servo valve counterbored recessed for orifices insert.

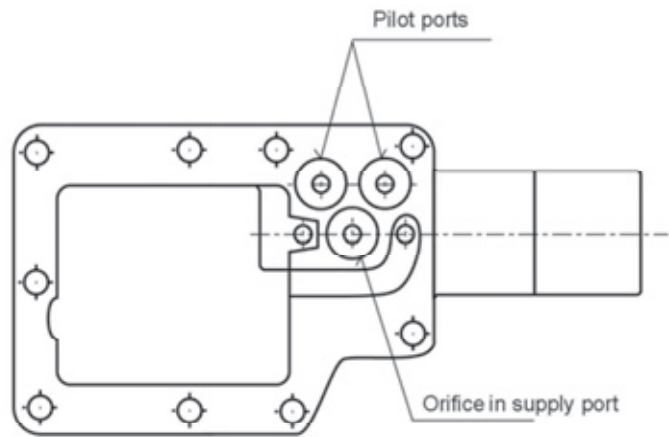

The reversing time in one flow direction can be extended by inserting an orifice in one of the pilot ports only.

Table 2.

Frame size	Diameter of orifice (mm)	Reversing time (s)
PV-20	0,76	3,78
	1,05	2,16
	1,60	1,14
	without orifice	0,60
PV-21	0,76	4,14
	1,05	2,34
	1,60	1,20
	without orifice	0,66
PV-22	0,76	6,06
	1,05	3,42
	1,60	1,74
	without orifice	0,96
PV-23	0,76	6,24
	1,05	3,54
	1,60	1,80
	without orifice	1,02

Frame size	Diameter of orifice (mm)	Reversing time (s)
PV-24	0,76	10,20
	1,05	5,82
	1,60	2,88
	without orifice	1,68
PV-25	0,76	11,58
	1,05	5,92
	1,60	3,12
	without orifice	1,86
PV-26	0,76	29,70
	1,05	16,20
	1,60	7,50
	without orifice	3,78
PV-27	0,76	30,90
	1,05	15,72
	1,60	7,80
	without orifice	5,64

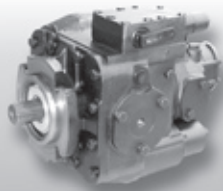

DIMENSIONS

Table 3. Dimensions (mm)

Frame size	A	A ₁	B	B ₁	B ₂	B ₃	C	D	D ₃	D ₄	D ₅	E	F +0,4	G
PV-20	190	146	47,6	112,7	100	122	56	162	127 ^{-0,005}	84	25,4	56	15	163
PV-21	191	146	48	124	110	131						70	15	172
PV-22	194	194	48	133	113	135						83	15	172
PV-23	194	194	49	150,8	123,8	146						90	15	190,4
PV-24	213	204	70	167	132	153	75	229	152,4	98		133	21,3	213
PV-25	286	254	80	174	142	162	77	317,5	165,1	98		160	21,3	260
PV-26	285	240	81	197	153	174		317,5	165,1	110		180	21,3	287,4
PV-27	300	274	86	212	172	193		350	177,8	114		208	27,7	317,4

Frame size	G ₁	H	H ₁	H ₂	H ₃	L	L ₁	L ₂	S	M	N	R ₁	S ₁
PV-20	81,03	340	270	284	352	224	161,2	93,7	19 ^{-0,25}	94,7	55,6	68	100
PV-21	86	358	282	301	367	246	174	106		108,7	65	68	107
PV-22	86	381	311	314	381	256	188	119		112,7	68,3	68,3	111
PV-23	95,2	395	320	327	395	270	194	127		127,6	77,8	68,3	117
PV-24	106,5	498	377	412	510	318	239	169		146	87,3	76	148
PV-25	130	560	423	457	560	366	264	196		153,7	97	76	171
PV-26	143,7	584	451	486	614	388	283	215		170,3	108	76	162
PV-27	158,7	656	475	578	656	433	311	244		187,2	127	76	198

Frame size	T	U	V	V ₁	V ₃	X	Y	Z	W	d	d ₁	f
PV-20	9,4 ^{+0,2}	19	151	113	115,9	159	3	3	3/8-16 UNC-2B	34,5 ^{-0,17}	M10-5H	16
PV-21			160	122	128,6	152	6,35	6,35				
PV-22			165	123	128,6	146	9,5	9,5		37,68 ^{-0,18}		17,5
PV-23			171	134	139,8	140	12,7	12,7				
PV-24		21	186	154	152,3	173	14	14	5/8-11 UNC-2B	44,03	M14-5H	23,5
PV-25			199	175	165,1	219	16	16				
PV-26			201	214	167,4	235	14,3	16,3				
PV-27			225	216	190,5	246	17,5	17,5				

Frame size	e	h ₁	H ₂	k	l	l ₁	α	m	n	
PV-20	6,73	62	51,16	48	12,5	min20	45°	52,4	26,2	H - with charge pump 12cm ³ (sizes PV-20 - 23) 33cm ³ (size PV-25) H3 - with charge pump 18cm ³ (sizes PV-20 - 23) 33cm ³ (size PV-24) 66cm ³ (size PV-25)
PV-21		68	54							
PV-22		71,4	60,5							
PV-23		77,7	65							
PV-24		88,5	68,2	67	12,45	30				
PV-25		98	74			30				
PV-26		100	79,4			36,7				
PV-27		116	95,3			30				

Frame size	Port A and B	P _{1,2} drain	Port R gear pump	M ₁ , M ₂ , Z ₂
PV-20 - 24	SAE flange, 3000 psi 4 threads, 3/8-16 UNC-2B, 18 deep	7/8-14 UNF-2B	7/8-14 UNF-2B	7/16 UNF-2B SAE straight thread „O“ ring boss
PV-25	SAE flange, size 1 ^{1/2} 4 threads, 6000 psi, 5/8-11 UNC-2B 35 deep	1 ^{5/16} - 12 UN-2B	1 ^{5/16} - 12 UN-2B	
PV-26		1 7/8-12 UNF-2B	1 ^{5/16} - 12 UN-2B	
PV-27		SAE straight threads „O“ ring boss	SAE flange, size 1 ^{1/4} 3000 psi, 4 threads 7/16-14 UNC-2B	

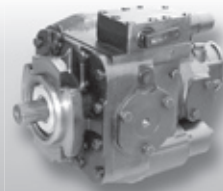
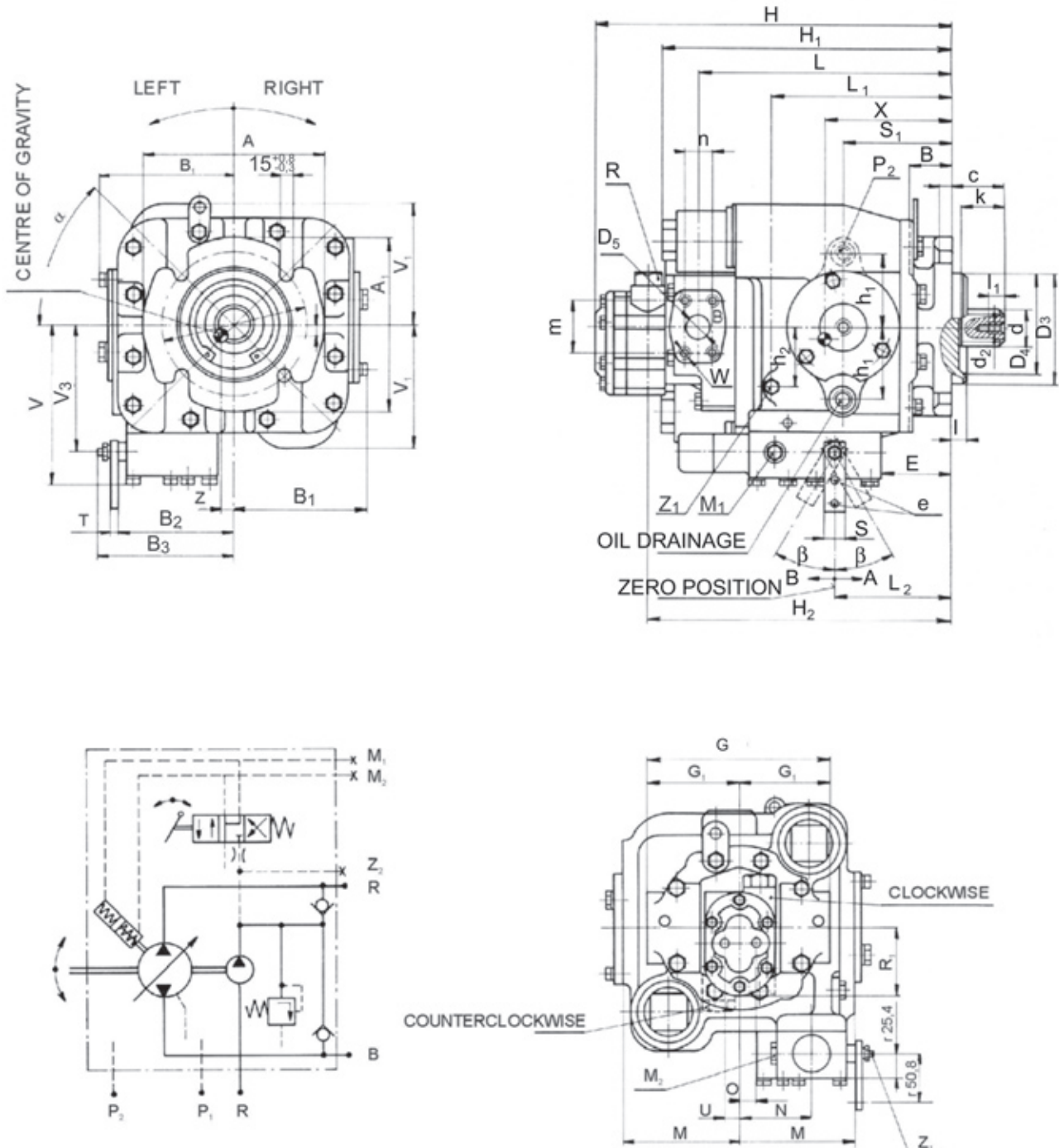

FIGURE 8 OUTLINE DRAWING FOR AXIAL PISTON VARIABLE DISPLACEMENT PUMP, SERIES 20



Deviating control lever of servo - vave in direction:

- A: Causes high pressure in „A“ orifice in clockwise pump
Causes high pressure in „B“ orifice in counter clockwise pump
- B: Causes high pressure in „B“ orifice in clockwise pump
Causes high pressure in „A“ orifice in counter clockwise pump

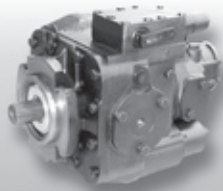
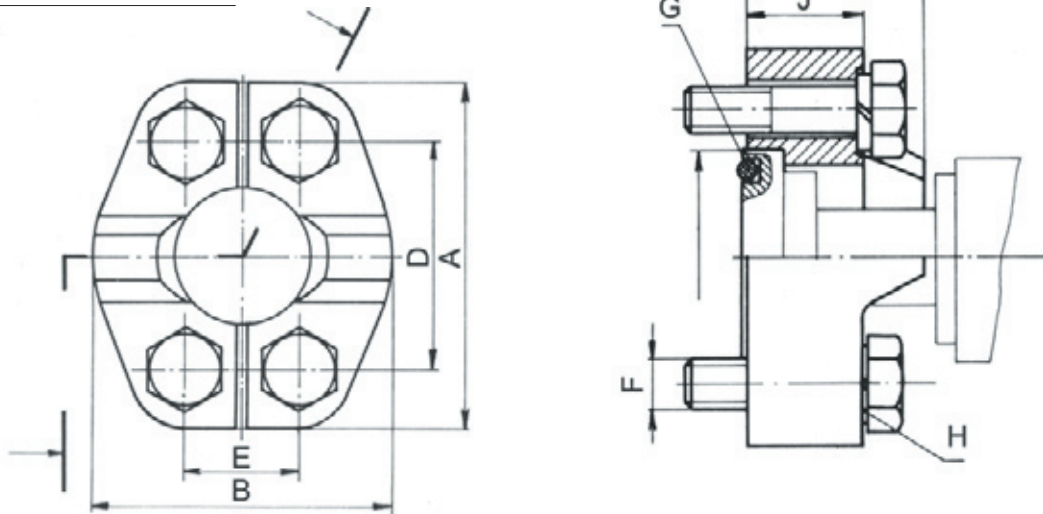

FIGURE 9: HOSE FLANGE



Dimensions (mm)

Frame size	A	B	C	D-0,1	E-0,1	F	H	J
PV-20 - 24	81	70	35	52,4	26,2	3/8-16 UNC-2A	Washer 10,2	22,5
PV-25 - 27	112	95	46	79,4	36,5	5/8-11 UNC-2A	Washer 16	30

FIGURE 10: FLANGE FOR PIPING

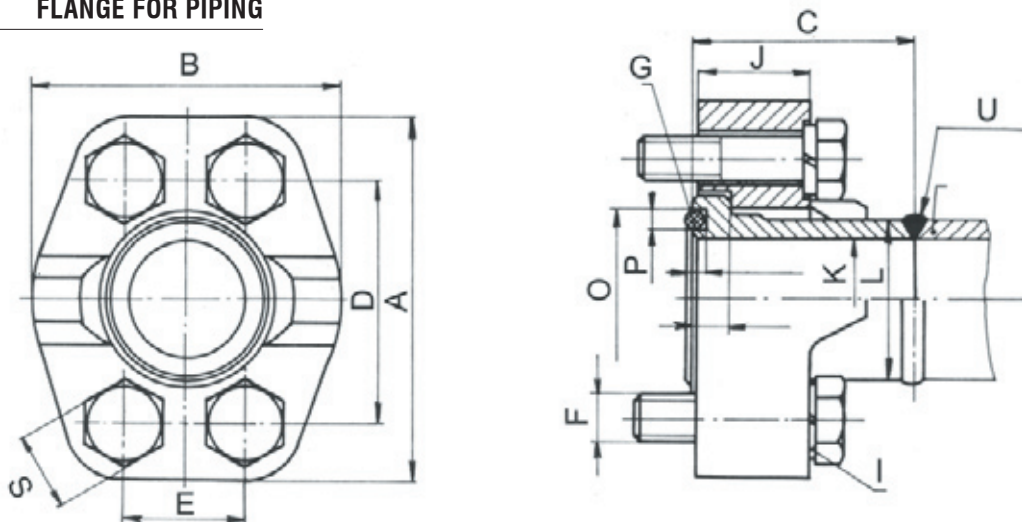

Frame size	A	B	C	D-0,1	E-0,1	F	H	J
PV-20 - 24	81	70	40	52,4	26,2	3/8-16 UNC-2A	Washer 10	22,5
PV-25 - 27	112	95	65	79,4	36,5	5/8-11 UNC-2A	Washer 16	30

Frame size	K	L	M - 0,1	N - 0,1	O	P + 0,2	U
PV-20 - 24	28	38	8	2,8	39,7±0,05	4	V5 - 104
PV-25 - 27	38	50	12,6	2,8	53,9±0,01	4	V6 - 158

Note:

Flange according to SAE J 518 c

Frame size 20 - 24: size 1, 5000 psi, torque for screw tightening 3/8 - 16 UNC2A: 37 - 42 Nm

Frame size 25 - 27: size 1 1/2, 6000 psi, torque for screw tightening 5/8 - 11 UNC2A: 158 - 181 Nm

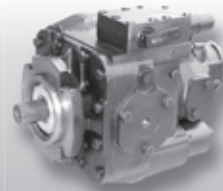

TYPE DESIGNATION

	1	2	3	4	5	6	7	8	9	10
	PV	XX	XXX	X	X	X	XX	XX	XX	XXX
1.	PV Pump Variable								10. 000 Standart ● XXX Special production number ○	
2.	Displacement $V_{g,max}$ [cm ³]									
	20	33,3								
	21	51,6								
	22	69,8								
	23	89,0								
	24	118,7								
	25	165,8								
	26	227,3								
	27	333,7								
3.	XXX TYPE OF CONTROL									
4.	R Clockwise L Counter clockwise V Reversible	Direction of shaft rotation								
5.	Dimension of the input shaft									
	A	14 teeth, 12/24 PITCH, $\varnothing 31,20$								
	B	19 teeth, 16/32 PITCH, $\varnothing 31,75$								
	C	21 teeth, 16/32 PITCH, $\varnothing 34,50$								
	D	23 teeth, 16/32 PITCH, $\varnothing 37,68$								
	E	27 teeth 16/32 PITCH, $\varnothing 44,03$								
	F	40 teeth 16/32 PITCH, $\varnothing 64,66$								
	G	3 teeth, 8/16 PITCH, $\varnothing 43,71$								
	I	20 teeth, 16/32 PITCH, $\varnothing 32,91$								
	J	cone 1:8, SAE J501, $\varnothing 41,27$								
	K	cone 1:8, SAE J501, $\varnothing 31,75$								
	L	parallel with key $\varnothing 34,925$;								
	M	parallel with key $\varnothing 44,45$;								
	P	15 teeth, 16/ 2 PITCH, $\varnothing 25,40$								
	R	13 teeth, 16/32 PITCH, $\varnothing 21,80$								
6.	Dimension of high pressure ports					Thread				
	A	SAE J518c, code 62, size 1", 6000PSI				7/16"-14 UNC-2A				
	B	SAE J518c, code 61, size 1", 5000PSI				3/8"-16 UNC-2A				
	C	ISO 6162, DN25, type II, 40 MPa				M12				
	D	SAE J518c, code 62, size 3/4", 6000PSI				3/8"-16 UNC-2B				
	E	SAE J518c, code 61, size 3/4", 5000PSI				3/8"-16 UNC-2B				
	F	ISO 6162, DN 19, type II, 40 MPa				M10				
7.	Charge gear pump									
	V_g									
	A	8,2 cm ³								
	B	12,3 cm ³								
	C	18,03 cm ³								
	D	18,85 cm ³								
	F	65,5 cm ³								
	NN	without charge pump								
	AA	8,2 + 8,2 cm ³								
	BA	12,3 + 8,2 cm ³								
	CA	18,3 + 8,2 cm ³								
8.	Pressure setting of gear pump									
	13	1.3 MPa (1.3 ± 0.05 MPa at 3.8 dm ³ .min ⁻¹)								●
	XX	other								○
	00	without charge pump								○

Other values according to mutual agreement, max 3,5 MPa

● - standard design
○ - available

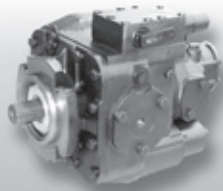

TYPES OF CONTROLS

WITHOUT CONTROL DEVICE

AAA	- without the mechanical-hydraulic servo valve, with top cover only
BBB	- without the mechanical-hydraulic servo valve, with joining piece and cover

MECHANICAL - HYDRAULIC

MHx 0	- mechanical-hydraulic servo valve - standard
MBx 0 1 2	- mechanical-hydraulic servo valve with a neutral position switch - empty - electric control; voltage 12 V = - electric control; voltage 24 V =
MCx 0 1 2	- mechanical-hydraulic servo valve with a straightway valve - hydraulic control - electric control; voltage 12 V = - electric control; voltage 24 V =
MDx 0 1 2	- MBx + MCx - hydraulic control - electric control; voltage 12 V = - electric control; voltage 24 V =

ELECTRICAL - HYDRAULIC

EHx 0 1 2	- electro-hydraulic servo valve - empty - MOOG - NC Servo
EVx 0 1 2	- three-positional distributor + pressure reducing valve (proportional) - empty - electric control; voltage 12 V = - electric control; voltage 24 V =
ERx 0 1 2 3 4 5 6 7 8 9	- three-positional distributor (non-continuous) - empty - electric control; voltage 12 V =, D _n 6 mm - electric control; voltage 24 V =, D _n 6 mm - electric control; voltage 12 V =, D _n 4 mm - electric control; voltage 24 V =, D _n 4 mm

HYDRAULIC

PHx	- hydraulic
0	- direct
1	- empty

AUTOMATIC

PRx H 1 2 3 4 5 6 7 8 9	- automatic direct regulation - constant power - hydraulic control - electric control; voltage 12 V =, D _n 6 mm - electric control; voltage 24 V =, D _n 6 mm - electric control; voltage 12 V =, D _n 4 mm - electric control; voltage 24 V =, D _n 4 mm
Qxx ↓ M H 0 1 2 3 4 5 6 7 8 9 P ↓ 1 2 3 4 5 6 7 8 9 0	- automatic control - constant rate of flow - mechanical-hydraulic servo valve - hydraulic control - empty - electric control; voltage 12 V =, D _n 6 mm - electric control; voltage 24 V =, D _n 6 mm - electric control; voltage 12 V =, D _n 4 mm - electric control; voltage 24 V =, D _n 4 mm - pneumatic control - rate of flow up to 10 l . min ⁻¹ - rate of flow up to 20 l . min ⁻¹ - rate of flow up to 30 l . min ⁻¹ - rate of flow up to 40 l . min ⁻¹ - rate of flow up to 50 l . min ⁻¹ - rate of flow up to 60 l . min ⁻¹ - rate of flow up to 70 l . min ⁻¹ - rate of flow up to 80 l . min ⁻¹ - rate of flow up to 90 l . min ⁻¹ - rate of flow up to 100 l . min ⁻¹ and higher
Rxx ↓ M H 0 1 2 3 4 5 6 7 8 9 ↓ 1 2 3 4 5 6 7 8 9	- automatic control - constant pressure - mechanical-hydraulic servo valve - hydraulic control - empty - electric control; voltage 12 V =, D _n 6 mm - electric control; voltage 24 V =, D _n 6 mm - electric control; voltage 12 V =, D _n 4 mm - electric control; voltage 24 V =, D _n 4 mm - pressure value 5 MPa - pressure value 10 MPa - pressure value 15 MPa - pressure value 20 MPa - pressure value 25 MPa - pressure value 30 MPa - pressure value 35 MPa - pressure value 40 MPa - on request

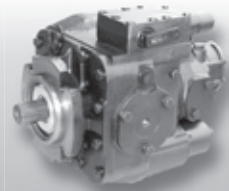

SPARE PARTS FOR VARIABLE PISTON PUMP

PV 20, PV 21, PV 22, PV 23, PV 24, PV 25, PV 26, PV 27

At your inquiry is needed to give number of spare parts from sketch and size of the pump.

1 – Servo Valve Assembly	44 – End Cap Gasket
2 – Charge Pump Assembly	45 – Front Cover Gasket
3 – Servo Cylinder	47 – Seal Spring
4 – Servo Piston	48 – Servo Spring
5 – Front Cover	49 – Nut
6 – Pump Housing	50 – Plastic Plug
7 – End Cap	51 – Plug
8 – Swash Plate	52 – Expander 05
9 – Check Valve	53 – Expander 09
10 – Cylinder Barrel	54 – Hex Head Screw
11 – Piston Assembly	55 – Hex Head Screw
12 – Bearing Plate	57 – Hex Head Screw
13 – Retainer Guide	58 – End Cap Screw
14 – Slipper Retainer	59 – End Cap Screw
15 – Spring Retainer	60 – Screw
16 – Spring Seat	61 – Hex Head Screw
17 – Spring Guide	62 – Pin
18 – Bearing Plate Pilot	63 – Pin
19 – Pin	64 – Drive Screw
20 – Cylinder Barrel Spring	65 – Pin
21 – Retainer Spring	66 – Pin
22 – Retaining Ring	67 – Retaining Ring
23 – Thrust Plate	68 – Retaining Ring
24 – Valve Plate	69 – Retaining Ring
25 – Trunnion	70 – O-Ring
26 – Seal Retainer	71 – O-Ring
27 – Rotating Seal	72 – O-Ring
28 – Stationary Seal	73 – O-Ring
29 – Drive Shaft	74 – O-Ring
30 – Servo Link	75 – O-Ring
31 – Sleeve Retainer	76 – O-Ring
32 – Spring Guide	77 – Front Bearing
33 – Shim	78 – Rear Bearing
34 – Washer	79 – Trunnion Bearing
35 – Orifice	80 – Washer
36 – Spacer	81 – Washer
37 – Control Handle	82 – Washer
38 – Loop	83 – Drive Screw
39 – Cap	84 – Washer
41 – Control Valve Gasket	86 – Socket Head Screw
42 – Charge Pump Gasket	87 – O-Ring
43 – Shim Pack	89 – Hex Head Screw

AXIAL PISTON PUMPS PV
 SERIES 20 CLOSED CIRCUIT

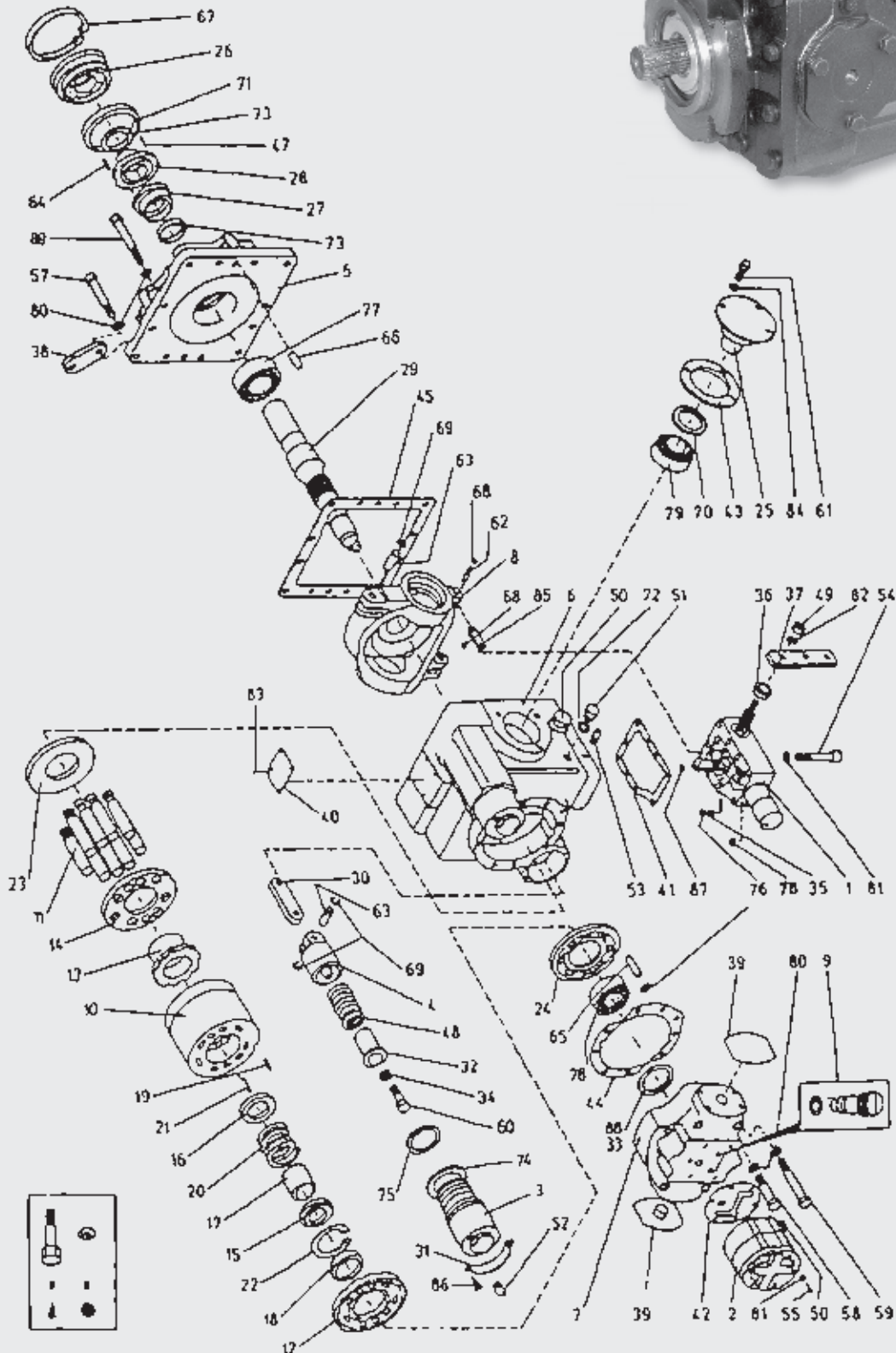
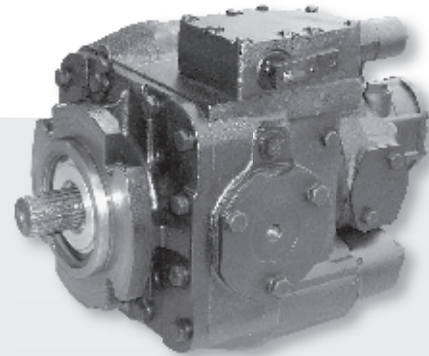
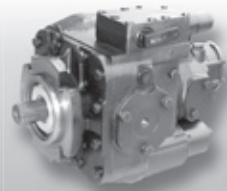

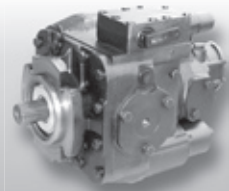

SPARE PARTS FOR SERVOVALVE ASSEMBLY FOR VARIABLE PISTON PUMP

PV 20, PV 21, PV 22, PV 23, PV 24, PV 25, PV 26, PV 27

At your inquiry is needed to give number of spare parts from sketch of servovalve assembly and size of the pump.

1 – Control Valve Housing	9 – Set Screw	16 – Stop	23 – O-Ring
2 – Lever Arm	10 – Retaining Nut	17 – Washer	24 – O-Ring
3 – Cover	11 – Retaining Nut	18 – Torsion Spring	25 – O-Ring
4 – Shaft	12 – Link	19 – Spring	26 – O-Ring
5 – Bushing	13 – Valve Link	20 – Plug	27 – Pin
6 – Spring Bushing	14 – Bushing	21 – Retaining Ring	28 – Retaining Ring
7 – Shaft Link	15 – Bushing	22 – Retaining Ring	29 – O-Ring
8 – Shuttle Valve			

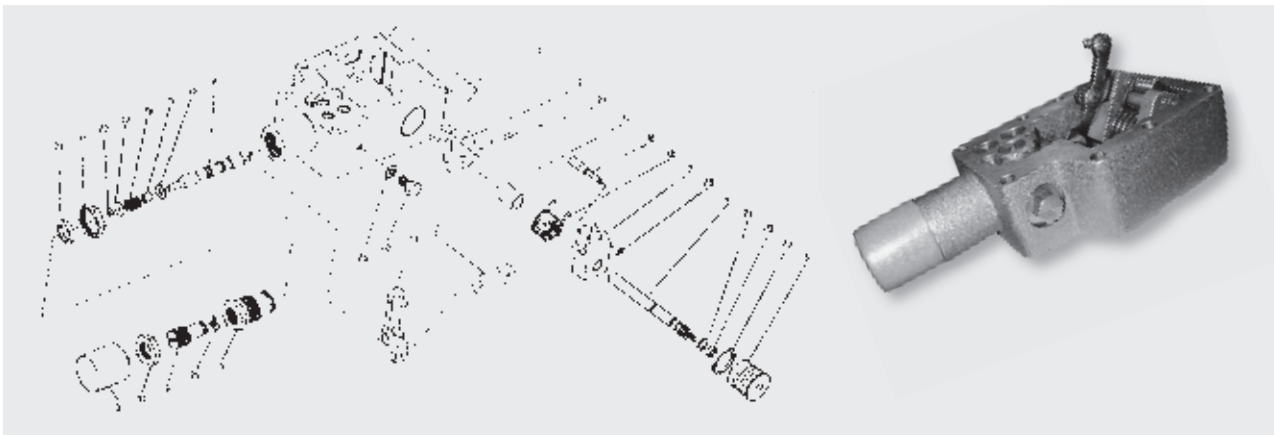

SPARE PARTS FOR CHARGE PUMP FOR VARIABLE PISTON PUMP

PV 20, PV 21, PV 22, PV 23, PV 24, PV 25, PV 26, PV 27

At your inquiry is needed to give number of spare parts from sketch of charge pump and size of the pump.

1 – Hex Head Screw	6 – Key	11 – Spring	15 – Pin
2 – Washer	7 – Drive Shaft	12 – O-Ring	16 – Pin
3 – End Cap	8 – Pin	13 – Shim	17 – Charge Pump Gasket
4 – Gear Set	9 – Pump Housing	14 – Plug	18 – Gasket
5 – Pin	10 – Relief Valve		

