

# 501 Ruggedized Shaft encoder, Incremental

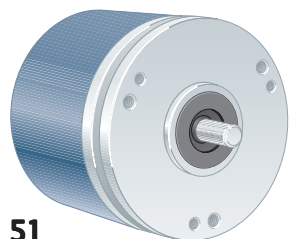

51

## Short description:

- >> 2 short-circuit protected outputs
- >> IP 67 at housing, IP 66 at shaft inlet
- >> 9...36 Vdc
- >> Robust housing for harsh environment
- >> Shock and vibration protected

## Suitable applications:

- >> Standard to demanding industrial applications
- >> Extra rugged design for harsh environments

## General information

Encoder data	
Type	RSI 501
Operating temperature	-40°C .. +70°C
Storage temperature	-40°C .. +85°C
Ingress protection class	IP-67 according to IEC 60529
At shaft inlet	IP-66 according to IEC 60529
Vibration (55 to 2000Hz)	< 300 m/s <sup>2</sup> according to IEC 60068-2-6 <sup>(1)</sup>
Shock (6ms)	< 2000 m/s <sup>2</sup> according to IEC 60068-2-27
Cover material	Aluminium
Cover surface treatment	Coated and cromated or anodized
Weight	Approx. 300g
Accuracy and resolution	
Line count	1..5 000 ppr
Dividing error	± 50 °el
Channel separation	90 ± 25 °el
Measuring steps	4 x Line count

## Flange option

Flange type	51, LL58
Outer diameter	ø58 mm
Mounting holes	3 x M3 & 3 x M4
Flange material	Aluminium
Surface treatment	Anodized

## Shaft option

Shaft type	Ø6 round	Ø6 with face	Ø10 round	Ø10 with face
Axial shaft load	100 N	100 N	100 N	100 N
Radial shaft load	120 N	120 N	120 N	120 N
Mech. permissible speed	3000 rpm (6000)	3000 rpm (6000)	3000 rpm (6000)	3000 rpm (6000)
Shaft material	Stainless steel	Stainless steel	Stainless steel	Stainless steel
Moment of inertia	1,9 x 10 <sup>-6</sup> kgm <sup>2</sup>	1,9 x 10 <sup>-6</sup> kgm <sup>2</sup>	2,0 x 10 <sup>-6</sup> kgm <sup>2</sup>	2,0 x 10 <sup>-6</sup> kgm <sup>2</sup>

<sup>(1)</sup><150m/s<sup>2</sup> on encoders with connectors

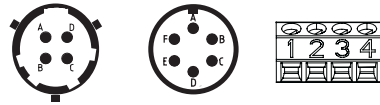

### Connection option

Connector type	Cable	4 pin PT	6 pin MS	Terminal
Function	Colour	PIN	PIN	PIN
S00	Yellow	B	D	3
S90	Green	A	A	4
+E Volt	Red	C	E	1
0 Volt	Blue	D	F	2
Case	Shield	Chassis	Chassis	Chassis
Connecting direction				
Axial	Yes	No	Yes	Yes
Radial	Yes	Yes	No	No

### Electrical option

<b>Power supply</b>	<b>9-36 V</b>
Polarity protected	Yes
<b>Output signals</b>	<b>HC-HTL</b>
Short circuit protected	Yes
Current consumption	55 mA at 24Vdc
Max consumption	Max 80 mA
Output load (max)	±40 mA
Output frequency (max)	100 kHz
$U_{high}$ at 10mA load	> +EV - 4.0 V
$U_{low}$ at 10mA load	< 2.5 V
Cable length (max)	350 m @ 100kHz

### Output circuit

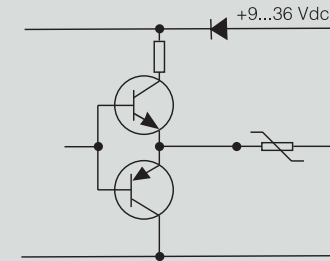

### Output signals

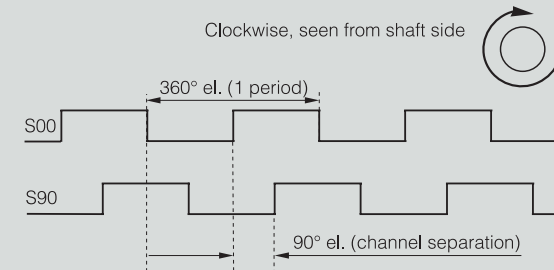

### Dimensions

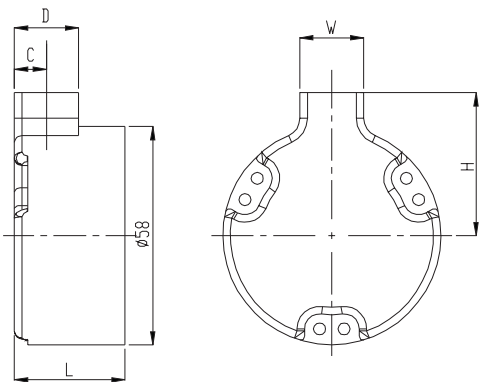

Connector	Orientation	L	H	W	D	C
Cable	Radial	29.4	34	17	17	8.5
	Axial	38.9	-	-	-	-
PT 4p	Radial	39.9	34.9	21	21	10.5
MS 6p	Axial	38.9	-	-	-	-
Terminal	Axial	29.4	-	-	-	-

### Flanges

#### 51, LL58

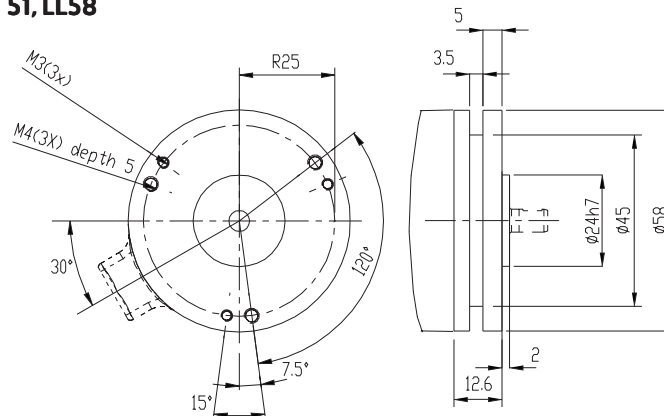



## Connectors

**Cable**  
5x2x0,25 shielded

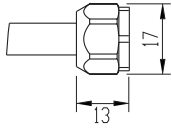

**4pin PT**

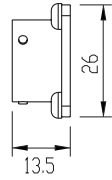

**6pin MS**

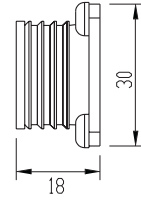

**Terminal**

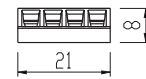

## Shafts

**6 mm with face**

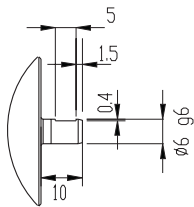

**6 mm round**

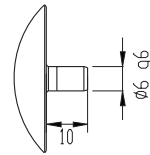

**10 mm with face**

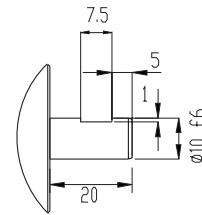

**10 mm round**

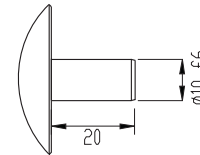

## Various combinations/example

**RSI 501 51**  
6 mm with face, radial PT

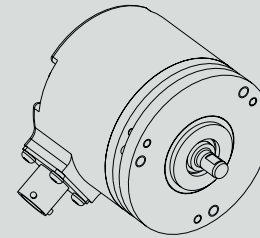

## Ordering information Tick your choice

Type	RSI 501				
Flange	51, LL58				
Shaft	Ø6 round	Ø6 with face	Ø10 round	Ø10 with face	
Electronics	Supply	9-36Vdc			
	Output	HC-HTL			
Connection	Cable	4 pin PT	6 pin MS	Terminal	
Connecting direction	Axial/Radial	Radial	Axial	Axial	
Line count	1..5000				

**Please, specify line count and cable length when ordering**

Ordering example: RSI 501 51 Ø6ro 9-36Vdc 1024ppr HC-HTL Terminal Axial

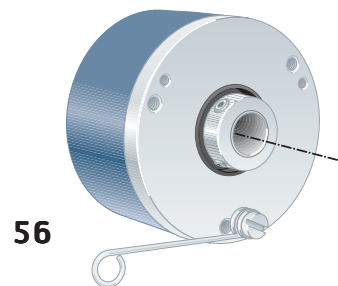

56

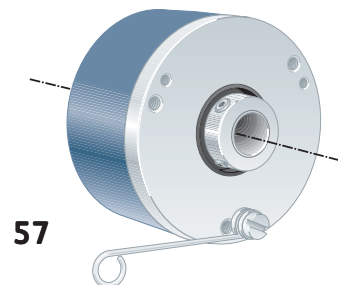

57

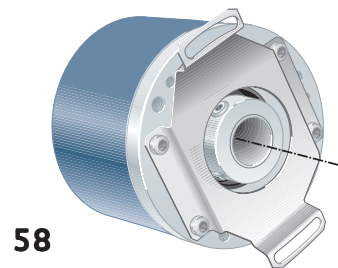

58

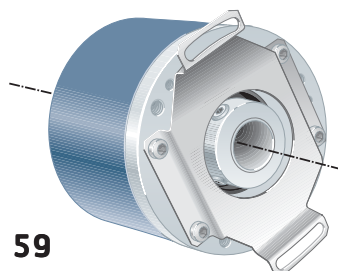

59

### Short description:

- >> 6 short-circuit protected outputs
- >> IP 67 at housing, IP 66 at shaft inlet
- >> 5 Vdc or 9...30 Vdc
- >> Robust housing for harsh environment
- >> Shock and vibration protected

### Suitable applications:

- >> Standard to demanding industrial applications

### General information

Encoder data		
Type	RHI 503	
Operating temperature	-40°C .. +70°C	
Storage temperature	-30°C .. +70°C	
Ingress protection class	IP-67 according to IEC 60529	
At shaft inlet	IP-66 according to IEC 60529	
Vibration (55 to 2000Hz)	< 300 m/s <sup>2</sup> according to IEC 60068-2-6 <sup>(1)</sup>	
Shock (6 ms)	< 2000 m/s <sup>2</sup> according to IEC 60068-2-27	
Cover material	Aluminium	
Cover surface treatment	Coated and cromated or anodized	
Weight	Approx. 300g	
Accuracy and resolution		
Line count	1..5000 ppr	5001..10 000 ppr
Dividing error	± 50 °el	± 90 °el
Channel separation	90 ± 25 °el	90 ± 45 °el
Measuring steps	4 x Line count	

### Flange option

Flange type	56, hollow-shaft	57, hollow-shaft	58, hollow-shaft	59, hollow-shaft
Type	Standard	Through going	Standard	Through going
Diameter	ø58mm	ø58mm	ø58mm	ø58mm
Flange material	Aluminium	Aluminium	Aluminium	Aluminium
Surface treatment	Anodized	Anodized	Anodized	Anodized
Torque support	Torque arm	Torque arm	Stator coupling	Stator coupling

### Shaft option

Hollow-shaft type	Ø8 mm	Ø10 mm	Ø12 mm	Ø14 mm
Axial shaft load	10 N	10 N	10 N	10 N
Radial shaft load	20 N	20 N	20 N	20 N
Mech. permissible speed	6000 rpm (12 000)	6000 rpm (12 000)	6000 rpm (12 000)	6000 rpm (12 000)
Shaft material	Stainless steel	Stainless steel	Stainless steel	Stainless steel
Moment of inertia	1,9 x 10 <sup>-6</sup> kgm <sup>2</sup>	1,9 x 10 <sup>-6</sup> kgm <sup>2</sup>	2,0 x 10 <sup>-6</sup> kgm <sup>2</sup>	2,0 x 10 <sup>-6</sup> kgm <sup>2</sup>

<sup>(1)</sup><150m/s<sup>2</sup> on encoders with connectors



### Connection option

Connector type	Cable	8 pin M12	12 pin EML	8 pin PT	6 pin MS
Function	Colour	PIN	PIN	PIN	PIN
S00	Yellow	4	5	D	D
S00 inverted	Black	5	6	C	C
S90	Green	3	8	A	A
S90 inverted	White	1	1	B	B
Sref	Brown	2	3	G	NA
Sref inverted	Violet	6	4	H	NA
+E Volt	Red	8	12	E	E
0 Volt	Blue	7	10	F	F
STATUS	Grey	NA	7	NA	NA
Housing	Shield	Chassis	Chassis	Chassis	Chassis
<b>Connecting direction (flange option -56, -58)</b>					
Axial	Yes	Yes	Yes	Yes	Yes
Radial	Yes	Yes	Yes	Yes	No
<b>Connecting direction (flange option -57, -59)</b>					
Axial	No	No	No	No	No
Radial	Yes	Yes	Yes	Yes	No

### Electrical option

Power supply	5 V ±10%	9-30 V	
Polarity protected	No	Yes	
Output signals	TTL <sup>1</sup>	HTL	RS-422
Short circuit protected	Yes	Yes	Yes
Current consumption	45 mA	50 mA at 24Vdc	25 mA at 24Vdc
Max consumption	75 mA	75 mA	40 mA
Output load (max)	±20 mA	±40 mA	±20 mA
Output frequency (max)	300 kHz	300 kHz	300 kHz
U <sub>high</sub> at 10mA load	> 3.0 V	> +EV - 2.0 V	> 3.0 V
U <sub>low</sub> at 10mA load	< 0.4 V	< 1.15 V	< 0.4 V
Cable length (max)	50 m	200 m @ 50 kHz	1 km (TIA/EIA-422-B)
STATUS output	Yes	Yes	Yes
High level	Encoder OK	Encoder OK	Encoder OK
Low level	Warning/Failure	Warning/Failure	Warning/Failure

<sup>1</sup>TTL output comply to the RS-422 standard when differential transmission is used NA=Not Available

### Output circuit

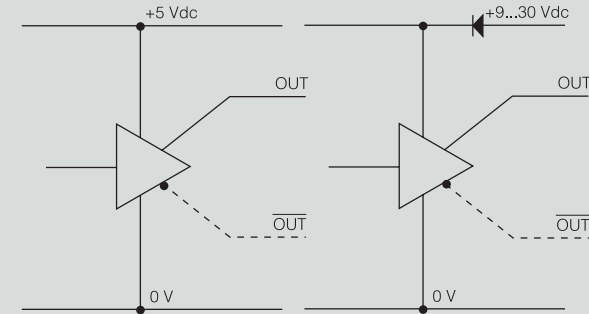

### Output signals

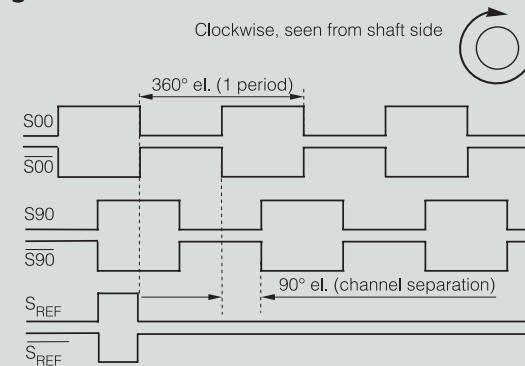

### Status outputs

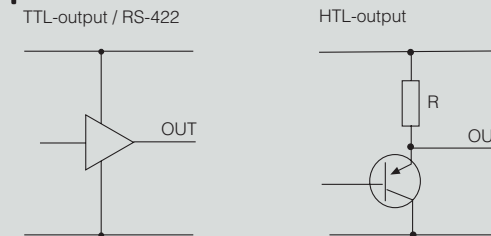

## Dimensions

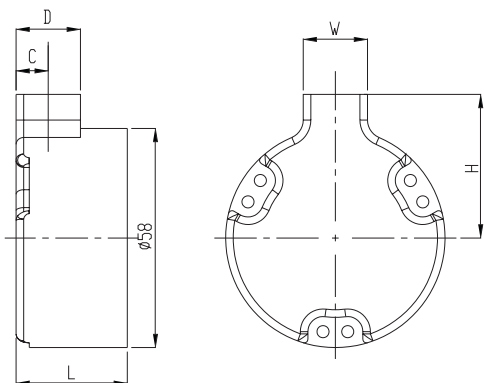

Connector	Orientation	L	H	W	D	C
Cable	Radial $\varnothing 58$	29.4	34	17	17	8.5
	Axial	38.9	-	-	-	-
EML	Radial	29.4	32	27	27	13.5
	Axial	38.9	-	-	-	-
PT 8p	Radial	29.4	41	27	27	13.5
	Axial $\varnothing 58$	38.9	-	-	-	-
MS 6p	Radial	-	-	-	-	-
	Axial	38.9	-	-	-	-
M12 8p	Radial	29.4	38	27	27	9.5
	Axial	38.9	-	-	-	-

## Shafts

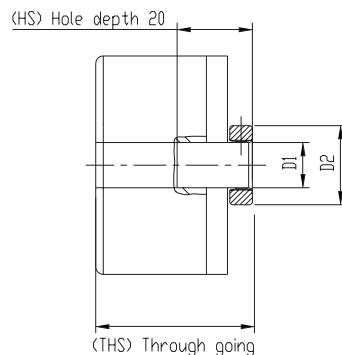

	D1	D2
$\varnothing 8\text{mm}$	$\varnothing 8$ G7	$\varnothing 19$
$\varnothing 10\text{mm}$	$\varnothing 10$ G7	$\varnothing 19$
$\varnothing 12\text{mm}$	$\varnothing 12$ G7	$\varnothing 21$
$\varnothing 14\text{mm}$	$\varnothing 14$ G7	$\varnothing 23$

## Flanges

### 56 and 57

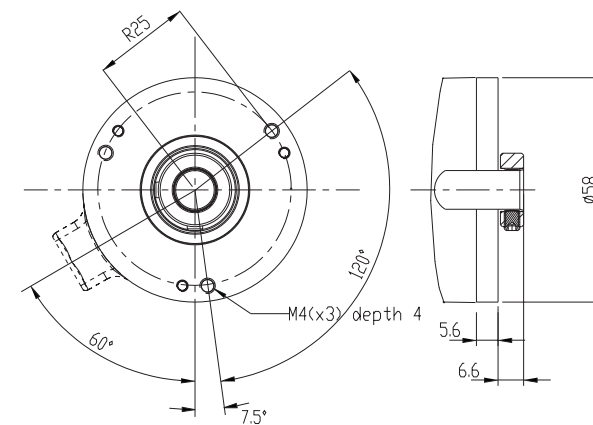

### 58 and 59

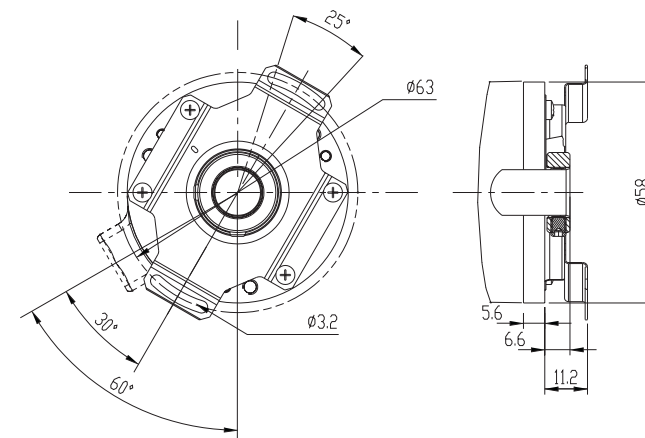



## Connectors

**Cable**  
5x2x0,25 shielded

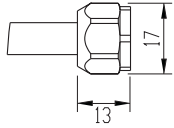

**8pin M12**

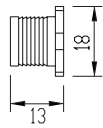

**12pin EML**

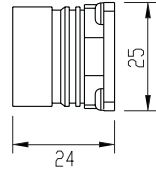

**8pin PT**

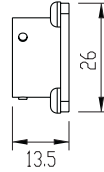

**6pin MS**

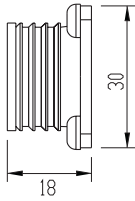

## Various combinations/examples

**RHI 503 56** 12 mm, axial MS

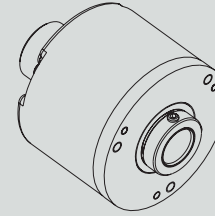

**RHI 503 57** 8 mm, radial cable

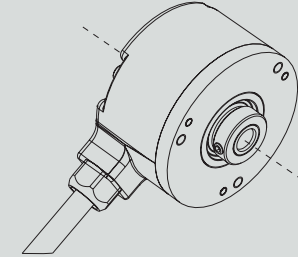

**RHI 503 58** 10 mm, radial EML

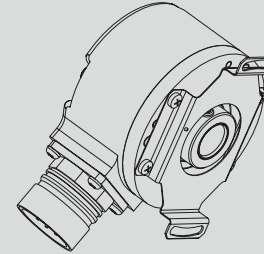

**RHI 503 59** 10 mm, radial cable

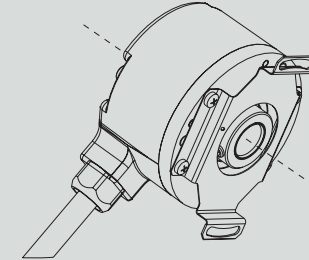

## Ordering information Tick your choice

Type	RHI 503				
Flange	56, HS	57, THS	58, HS	59, THS	
Shaft	Ø8mm	Ø10mm	Ø12mm	Ø14mm	
Electronics <sup>(1)</sup>	Supply	5Vdc			
	Output	TTL	HTL	RS-422	
Connection	Cable	8 pin M12	12 pin EML	8 pin PT	6 pin MS
Connecting direction	HS	Axial/Radial	Axial/Radial	Axial/Radial	Axial
	THS	Radial	Radial	Radial	Radial
Line count	1..5000	5001..10 000			

<sup>(1)</sup> Possible combinations: 5Vdc/TTL, 9-30Vdc/HTL or 9-30Vdc/RS-422

HS Hollow-shaft THS Through going hollow-shaft

**Please, specify line count and cable length when ordering**

Ordering example: RHI 503 58 Ø10 5Vdc 1024ppr TTL 12 pin EML Radial



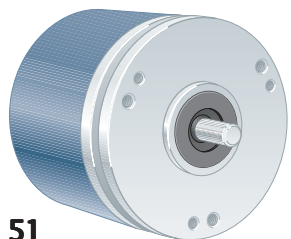

51

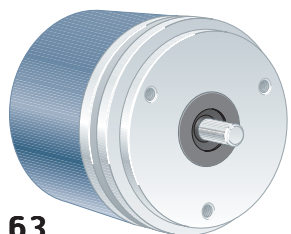

63

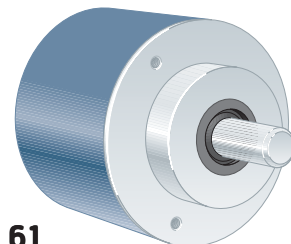

61

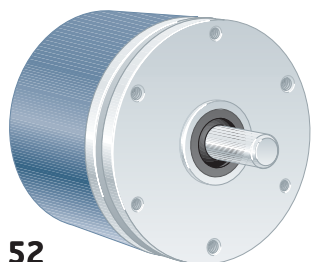

52

### Short description:

- >> 6 short-circuit protected outputs
- >> IP 67 at housing, IP 66 at shaft inlet
- >> 5 Vdc or 9...30 Vdc
- >> Robust housing for harsh environment
- >> Shock and vibration protected

### Suitable applications:

- >> Standard to demanding industrial applications

### General information

Encoder data		
Type	RSI 503	
Operating temperature	-40°C .. +70°C	
Storage temperature	-30°C .. +70°C	
Ingress protection class	IP-67 according to IEC 60529	
At shaft inlet	IP-66 according to IEC 60529	
Vibration (55 to 2000Hz)	< 300 m/s <sup>2</sup> according to IEC 60068-2-6 <sup>(1)</sup>	
Shock (6ms)	< 2000 m/s <sup>2</sup> according to IEC 60068-2-27	
Cover material	Aluminium	
Cover surface treatment	Coated and cromated or anodized	
Weight	Approx. 300g	
Accuracy and resolution		
Line count	1..5000 ppr	5001..10 000 ppr
Dividing error	± 50 °el	± 90 °el
Channel separation	90 ± 25 °el	90 ± 45 °el
Measuring steps	4 x Line count	

### Flange option

Flange type	51, LL58	63, Synchro	61, Clamping	52, LL68
Outer diameter	ø58 mm	ø58 mm	ø58 mm	ø68 mm
Mounting holes	3 x M3 & 3 x M4	3 x M4	3 x M3	3 x M3 & 3 x M4
Flange material	Aluminium	Aluminium	Aluminium	Aluminium
Surface treatment	Anodized	Anodized	Anodized	Anodized

### Shaft option

Shaft type	Ø6 round	Ø6 with face	Ø10 round	Ø10 with face
Axial shaft load	50 N	50 N	50 N	50 N
Radial shaft load	60 N	60 N	60 N	60 N
Mech. permissible speed	6000 rpm (12 000)	6000 rpm (12 000)	6000 rpm (12 000)	6000 rpm (12 000)
Shaft material	Stainless steel	Stainless steel	Stainless steel	Stainless steel
Moment of inertia	1,9 x 10 <sup>-6</sup> kgm <sup>2</sup>	1,9 x 10 <sup>-6</sup> kgm <sup>2</sup>	2,0 x 10 <sup>-6</sup> kgm <sup>2</sup>	2,0 x 10 <sup>-6</sup> kgm <sup>2</sup>

<sup>(1)</sup><150m/s<sup>2</sup> on encoders with connectors

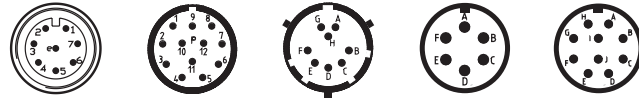

### Connection option

Connector type	Cable	8 pin M12	12 pin EML	8 pin PT	6 pin MS	10 pin MS
Function	Colour	PIN	PIN	PIN	PIN	PIN
S00	Yellow	4	5	D	D	D
S00 inverted	Black	5	6	C	C	C
S90	Green	3	8	A	A	A
S90 inverted	White	1	1	B	B	B
Sref	Brown	2	3	G	NA	G
Sref inverted	Violet	6	4	H	NA	H
+E Volt	Red	8	12	E	E	E
0 Volt	Blue	7	10	F	F	F
STATUS	Grey	NA	7	NA	NA	I
Case	Shield	Chassis	Chassis	Chassis	Chassis	Chassis
<b>Connecting direction (available on flange option -51, -63, -61)</b>						
Axial	Yes	Yes	Yes	Yes	Yes	Yes
Radial	Yes	Yes	Yes	Yes	No	Yes
<b>Connecting direction (available on flange option -52)</b>						
Axial	No	No	No	Yes	No	Yes
Radial	Yes	No	No	No	No	No

### Electrical option

Power supply	5 V ±10%	9-30 V	
Polarity protected	No	Yes	
Output signals	TTL <sup>1</sup>	HTL	RS-422
Short circuit protected	Yes	Yes	Yes
Current consumption	45 mA	50 mA at 24Vdc	25 mA at 24Vdc
Max consumption	75 mA	75 mA	40 mA
Output load (max)	±20 mA	±40 mA	±20 mA
Output frequency (max)	300 kHz	300 kHz	300 kHz
U <sub>high</sub> at 10mA load	> 3.0 V	> +EV - 2.0 V	> 3.0 V
U <sub>low</sub> at 10mA load	< 0.4 V	< 1.15 V	< 0.4 V
Cable length (max)	50 m	200 m @ 50 kHz	1 km (TIA/EIA-422-B)
STATUS output	Yes	Yes	Yes
High level	Encoder OK	Encoder OK	Encoder OK
Low level	Warning/Failure	Warning/Failure	Warning/Failure

<sup>1</sup>TTL output comply to the RS-422 standard when differential transmission is used NA=Not Available

### Output circuit

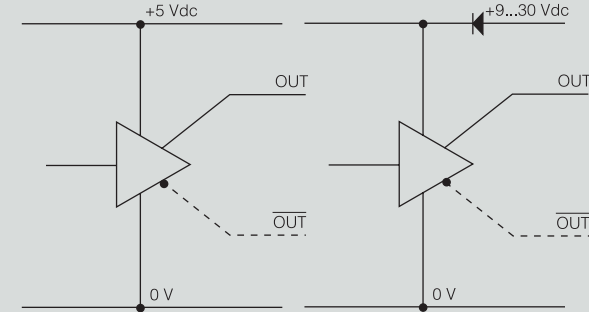

### Output signals

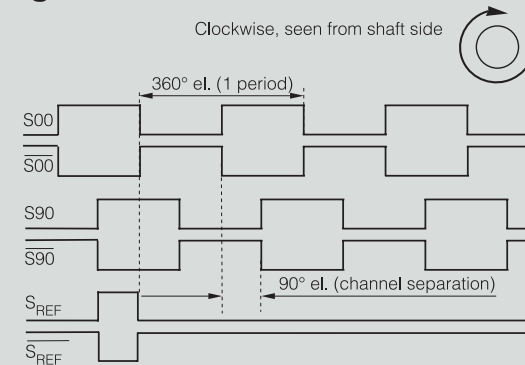

### Status outputs

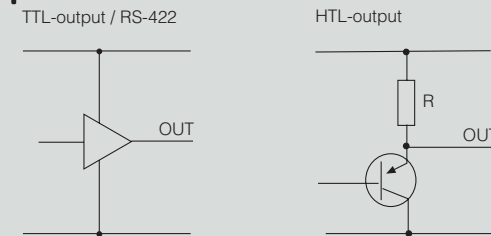

## Dimensions

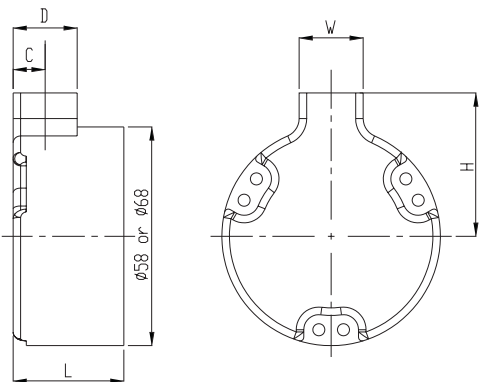

Connector	Orientation	L	H	W	D	C
Cable	Radial $\varnothing 58$	29.4	34	17	17	8.5
	Radial $\varnothing 68$	44.7	34	0	0	14
	Axial	38.9	-	-	-	-
EML	Radial	29.4	32	27	27	13.5
	Axial	38.9	-	-	-	-
PT 8p	Radial	29.4	41	27	27	13.5
	Axial $\varnothing 58$	38.9	-	-	-	-
	Axial $\varnothing 68$	44.7	-	-	-	-
MS 6p	Radial	-	-	-	-	-
	Axial	38.9	-	-	-	-
MS 10p	Radial	-	-	-	-	-
	Axial $\varnothing 58$	43.9	-	-	-	-
	Axial $\varnothing 68$	44.7	-	-	-	-
M12 8p	Radial	29.4	38	27	27	9.5
	Axial	38.9	-	-	-	-

## Flanges

### 51, LL58

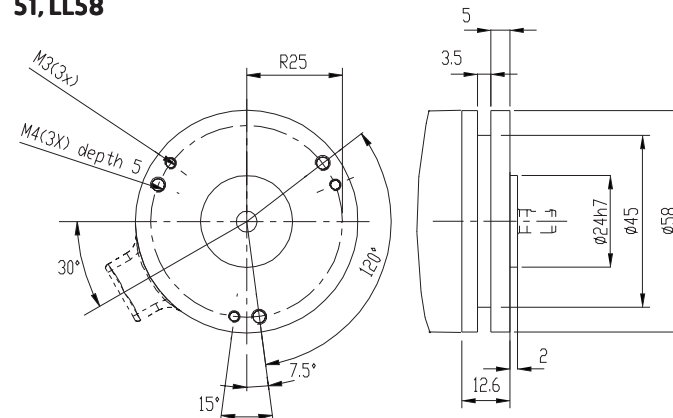

### 63, Synchro

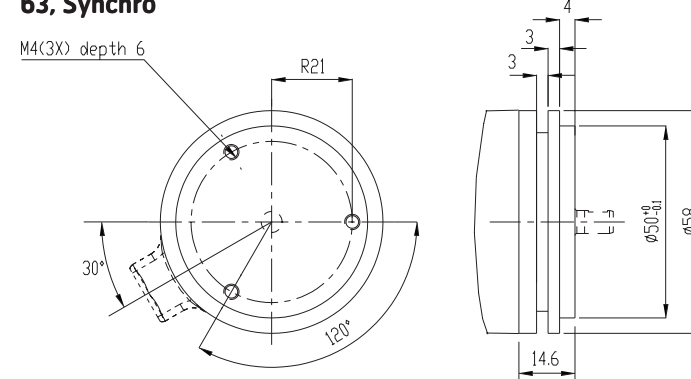

### 61, Clamping

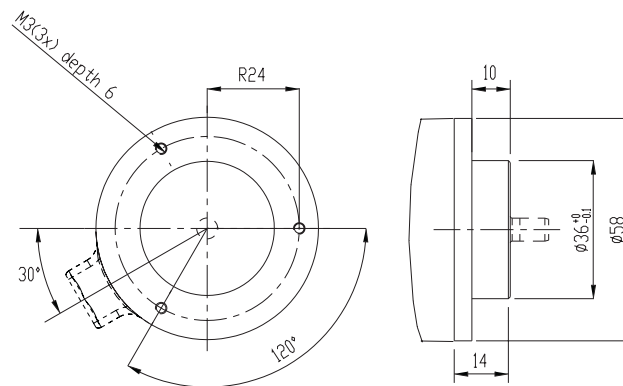

### 52, LL68

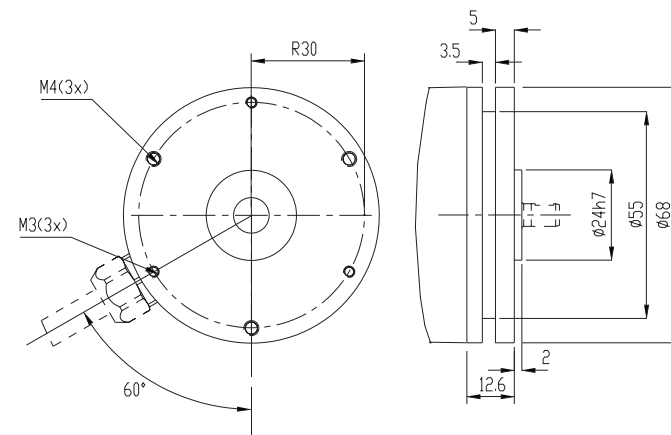

## Connectors

**Cable**  
5x2x0,25 shielded

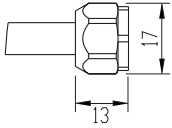

**8pin M12**

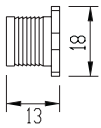

**12pin EML**

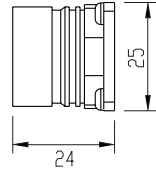

**8pin PT**

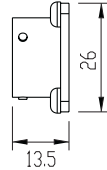

**6pin MS**

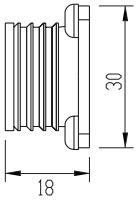

**10pin MS**

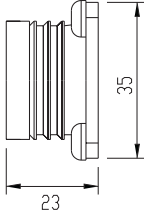

## Shafts

**6 mm with face**

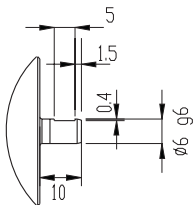

**6 mm round**

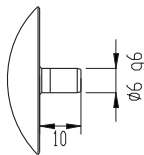

**10 mm with face**

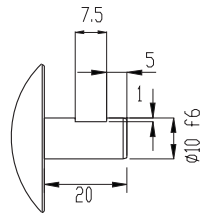

**10 mm round**

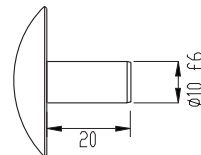

## Various combinations/examples

**RSI 503 51**

10 mm with face, axial cable

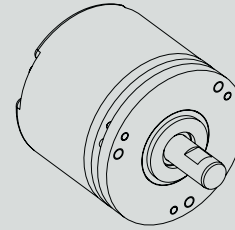

**RSI 503 63**

6 mm with face, radial PT

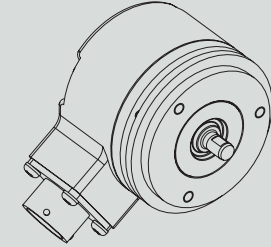

**RSI 503 61**

6 mm round, radial cable

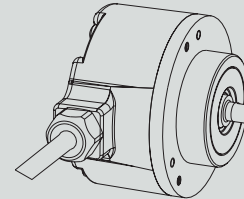

**RSI 503 52**

6 mm with face, radial cable

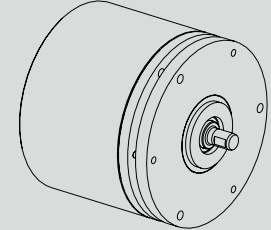

## Ordering information Tick your choice

Type	RSI 503					
Flange	51, LL58	63, Synchro	61, Clamping	52, LL68		
Shaft	Ø6 round	Ø6 with face	Ø10 round	Ø10 with face		
Electronics <sup>(1)</sup>	Supply	5Vdc	9-30Vdc			
	Output	TTL	HTL	RS-422		
Connection	Cable	8 pin M12	12 pin EML	8 pin PT	6 pin MS	10 pin MS
Connecting direction	Axial <sup>2</sup> /Radial	Axial <sup>2</sup> /Radial <sup>2</sup>	Axial <sup>2</sup> /Radial <sup>2</sup>	Axial/Radial <sup>2</sup>	Axial <sup>2</sup>	Axial/Radial <sup>2</sup>
Line count	1..5000	5001..10 000				

<sup>(1)</sup> Possible combinations: 5Vdc/TTL, 9-30Vdc/HTL or 9-30Vdc/RS-422

<sup>(2)</sup> Not available on flange option -52, LL68

**Please, specify line count and cable length when ordering**

Ordering example: RSI 503 63 Ø6ro 5Vdc 1024ppr TTL 8 pin PT Axial

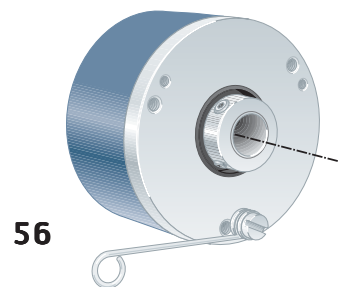

56

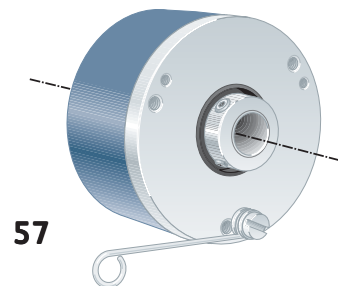

57

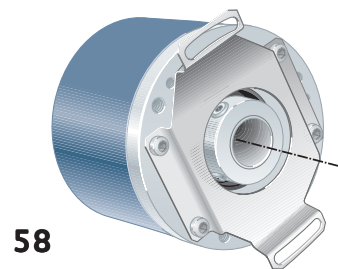

58

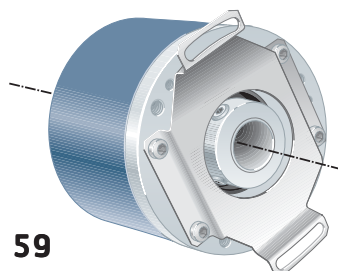

59

## Short description:

- >> 6 short-circuit protected outputs
- >> IP 67 at housing, IP 66 at shaft inlet
- >> 5 Vdc or 9...30 Vdc
- >> Robust housing for harsh environment
- >> Shock and vibration protected

## Suitable applications:

- >> Standard to demanding industrial applications
- >> High temperature applications

## General information

Encoder data		
Type	RHI 504	
Operating temperature	-20°C .. +100°C	
Storage temperature	-20°C .. +80°C	
Ingress protection class	IP-67 according to IEC 60529	
At shaft inlet	IP-66 according to IEC 60529	
Vibration (55 to 2000Hz)	< 300 m/s <sup>2</sup> according to IEC 60068-2-6 <sup>(1)</sup>	
Shock (6ms)	< 2000 m/s <sup>2</sup> according to IEC 60068-2-27	
Cover material	Aluminium	
Cover surface treatment	Coated and cromated or anodized	
Weight	Approx. 300g	
Accuracy and resolution		
Line count	1..5000 ppr	5001..10 000 ppr
Dividing error	± 50 °el	± 90 °el
Channel separation	90 ± 25 °el	90 ± 45 °el
Measuring steps	4 x Line count	

## Flange option

Flange type	56, hollow-shaft	57, hollow-shaft	58, hollow-shaft	59, hollow-shaft
Type	Standard	Through going	Standard	Through going
Diameter	ø58mm	ø58mm	ø58mm	ø58mm
Flange material	Aluminium	Aluminium	Aluminium	Aluminium
Surface treatment	Anodized	Anodized	Anodized	Anodized
Torque support	Torque arm	Torque arm	Stator coupling	Stator coupling

## Shaft option

Hollow-shaft type	Ø8 mm	Ø10 mm	Ø12 mm	Ø14 mm
Axial shaft load	10 N	10 N	10 N	10 N
Radial shaft load	20 N	20 N	20 N	20 N
Mech. permissible speed	6000 rpm (12 000)	6000 rpm (12 000)	6000 rpm (12 000)	6000 rpm (12 000)
Shaft material	Stainless steel	Stainless steel	Stainless steel	Stainless steel
Moment of inertia	1,9 x 10 <sup>-6</sup> kgm <sup>2</sup>	1,9 x 10 <sup>-6</sup> kgm <sup>2</sup>	2,0 x 10 <sup>-6</sup> kgm <sup>2</sup>	2,0 x 10 <sup>-6</sup> kgm <sup>2</sup>

<sup>(1)</sup><150m/s<sup>2</sup> on encoders with connectors



### Connection option

Connector type	Cable	8 pin M12	12 pin EML	8 pin PT	6 pin MS
Function	Colour	PIN	PIN	PIN	PIN
S00	Yellow	4	5	D	D
S00 inverted	Black	5	6	C	C
S90	Green	3	8	A	A
S90 inverted	White	1	1	B	B
Sref	Brown	2	3	G	NA
Sref inverted	Violet	6	4	H	NA
+E Volt	Red	8	12	E	E
0 Volt	Blue	7	10	F	F
STATUS	Grey	NA	7	NA	NA
Housing	Shield	Chassis	Chassis	Chassis	Chassis
<b>Connecting direction (flange option -56, -58)</b>					
Axial	Yes	Yes	Yes	Yes	Yes
Radial	Yes	Yes	Yes	Yes	No
<b>Connecting direction (flange option -57, -59)</b>					
Axial	No	No	No	No	No
Radial	Yes	Yes	Yes	Yes	No

### Electrical option

Power supply	5 V ±10%	9-30 V	
Polarity protected	No	Yes	
Output signals	TTL <sup>1</sup>	HTL	RS-422
Short circuit protected	Yes	Yes	Yes
Current consumption	45 mA	50 mA at 24Vdc	25 mA at 24Vdc
Max consumption	75 mA	75 mA	40 mA
Output load (max)	±20 mA	±40 mA	±20 mA
Output frequency (max)	300 kHz	300 kHz	300 kHz
U <sub>high</sub> at 10mA load	> 3.0 V	> +EV - 2.0 V	> 3.0 V
U <sub>low</sub> at 10mA load	< 0.4 V	< 1.15 V	< 0.4 V
Cable length (max)	50 m	200 m @ 50 kHz	1 km (TIA/EIA-422-B)
STATUS output	Yes	Yes	Yes
High level	Encoder OK	Encoder OK	Encoder OK
Low level	Warning/Failure	Warning/Failure	Warning/Failure

<sup>1</sup>TTL output comply to the RS-422 standard when differential transmission is used NA=Not Available

### Output circuit

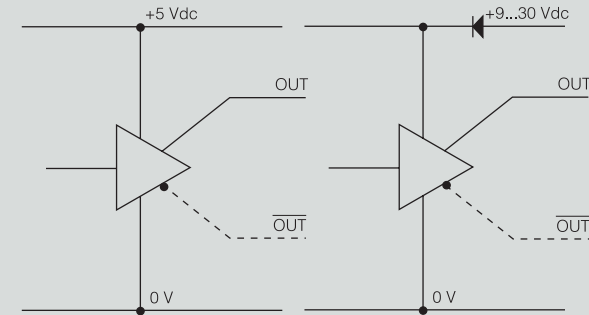

### Output signals

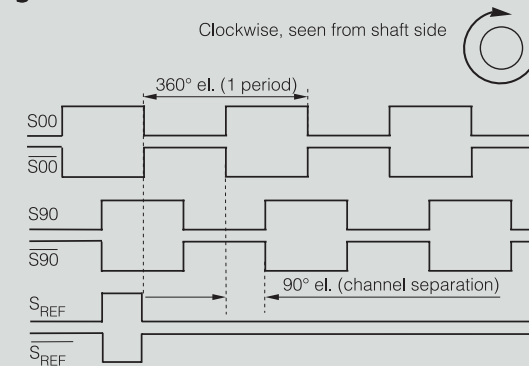

### Status outputs





## Dimensions

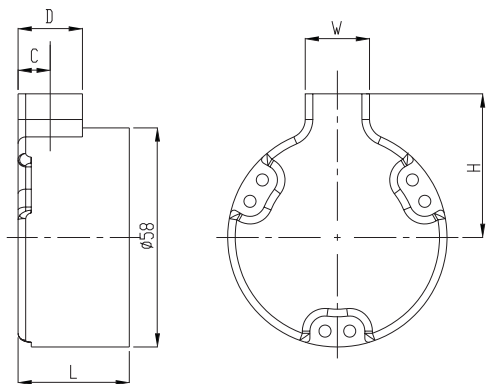

Connector	Orientation	L	H	W	D	C
Cable	Radial ø58	29.4	34	17	17	8.5
	Axial	38.9	-	-	-	-
EML	Radial	29.4	32	27	27	13.5
	Axial	38.9	-	-	-	-
PT 8p	Radial	29.4	41	27	27	13.5
	Axial ø58	38.9	-	-	-	-
MS 6p	Radial	-	-	-	-	-
	Axial	38.9	-	-	-	-
M12 8p	Radial	29.4	38	27	27	9.5
	Axial	38.9	-	-	-	-

## Shafts

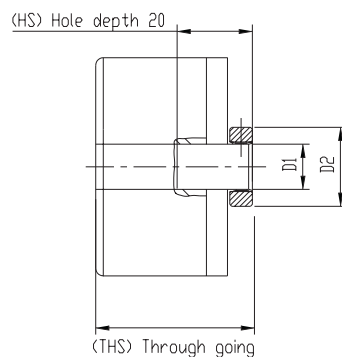

	D1	D2
ø8mm	ø8 G7	ø19
ø10mm	ø10 G7	ø19
ø12mm	ø12 G7	ø21
ø14mm	ø14 G7	ø23

## Flanges

### 56 and 57

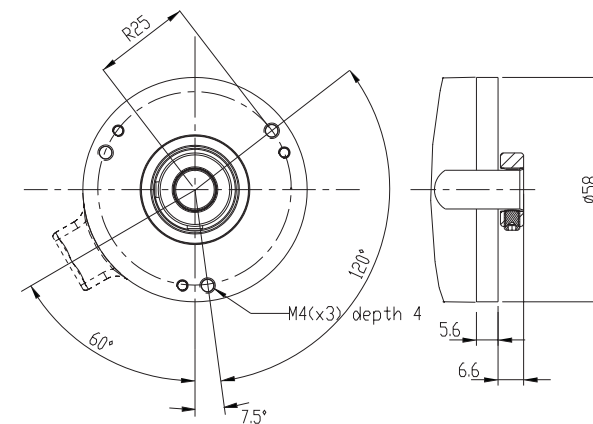

### 58 and 59

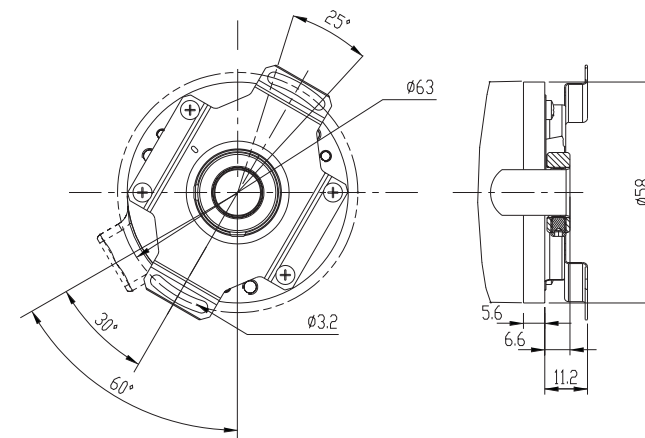

## Connectors

**Cable**  
5x2x0,25 shielded

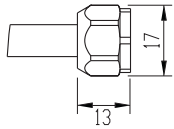

**8pin M12**

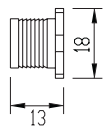

**12pin EML**

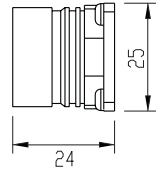

**8pin PT**

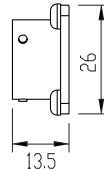

**6pin MS**

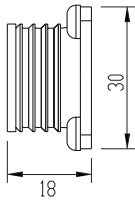

## Various combinations/examples

**RHI 503 56** 12 mm, axial MS

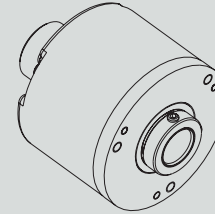

**RHI 503 57** 8 mm, radial cable

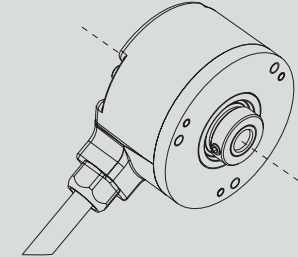

**RHI 503 58** 10 mm, radial EML

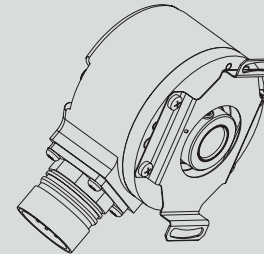

**RHI 503 59** 10 mm, radial cable

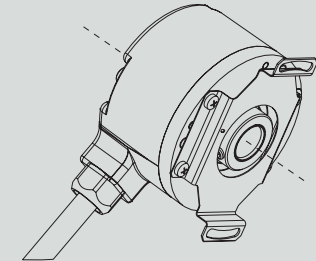

## Ordering information Tick your choice

Type	RHI 504				
Flange	56, HS	57, THS	58, HS	59, THS	
Shaft	Ø8mm	Ø10mm	Ø12mm	Ø14mm	
Electronics <sup>(1)</sup>	Supply	5Vdc			
	Output	TTL	HTL	RS-422	
Connection	Cable	8 pin M12	12 pin EML	8 pin PT	6 pin MS
Connecting direction	HS	Axial/Radial	Axial/Radial	Axial/Radial	Axial
	THS	Radial	Radial	Radial	Radial
Line count	1..5000	5001..10 000			

<sup>(1)</sup> Possible combinations: 5Vdc/TTL, 9-30Vdc/HTL or 9-30Vdc/RS-422

HS Hollow-shaft THS Through going hollow-shaft

**Please, specify line count and cable length when ordering**

Ordering example: RHI 504 58 Ø10 5Vdc 1024ppr TTL 12 pin EML Radial



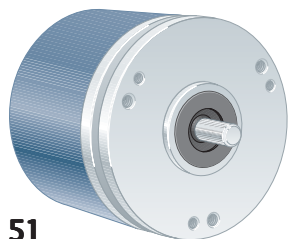

51

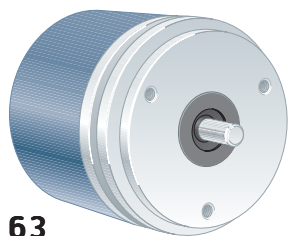

63

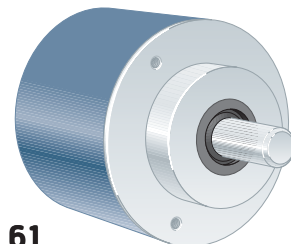

61

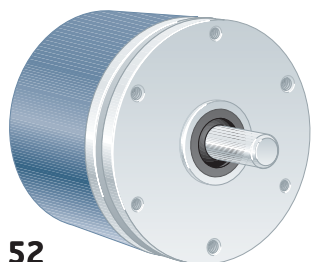

52

## Short description:

- >> 6 short-circuit protected outputs
- >> IP 67 at housing, IP 66 at shaft inlet
- >> 5 Vdc or 9...30 Vdc
- >> Robust housing for harsh environment
- >> Shock and vibration protected

## Suitable applications:

- >> Standard to demanding industrial applications
- >> High temperature applications

## General information

Encoder data		
Type	RSI 504	
Operating temperature	-20°C .. +100°C	
Storage temperature	-20°C .. +80°C	
Ingress protection class	IP-67 according to IEC 60529	
At shaft inlet	IP-66 according to IEC 60529	
Vibration (55 to 2000Hz)	< 300 m/s <sup>2</sup> according to IEC 60068-2-6 <sup>(1)</sup>	
Shock (6ms)	< 2000 m/s <sup>2</sup> according to IEC 60068-2-27	
Cover material	Aluminium	
Cover surface treatment	Coated and cromated or anodized	
Weight	Approx. 300g	
Accuracy and resolution		
Line count	1..5000 ppr	5001..10 000 ppr
Dividing error	± 50 °el	± 90 °el
Channel separation	90 ± 25 °el	90 ± 45 °el
Measuring steps	4 x Line count	

## Flange option

Flange type	51, LL58	63, Synchro	61, Clamping	52, LL68
Outer diameter	ø58 mm	ø58 mm	ø58 mm	ø68 mm
Mounting holes	3 x M3 & 3 x M4	3 x M4	3 x M3	3 x M3 & 3 x M4
Flange material	Aluminium	Aluminium	Aluminium	Aluminium
Surface treatment	Anodized	Anodized	Anodized	Anodized

## Shaft option

Shaft type	Ø6 round	Ø6 with face	Ø10 round	Ø10 with face
Axial shaft load	50 N	50 N	50 N	50 N
Radial shaft load	60 N	60 N	60 N	60 N
Mech. permissible speed	6000 rpm (12 000)	6000 rpm (12 000)	6000 rpm (12 000)	6000 rpm (12 000)
Shaft material	Stainless steel	Stainless steel	Stainless steel	Stainless steel
Moment of inertia	1,9 x 10 <sup>-6</sup> kgm <sup>2</sup>	1,9 x 10 <sup>-6</sup> kgm <sup>2</sup>	2,0 x 10 <sup>-6</sup> kgm <sup>2</sup>	2,0 x 10 <sup>-6</sup> kgm <sup>2</sup>

<sup>(1)</sup><150m/s<sup>2</sup> on encoders with connectors

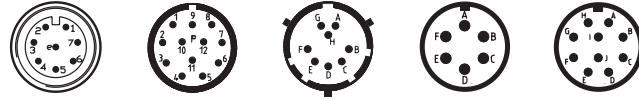

### Connection option

Connector type	Cable	8 pin M12	12 pin EML	8 pin PT	6 pin MS	10 pin MS
Function	Colour	PIN	PIN	PIN	PIN	PIN
S00	Yellow	4	5	D	D	D
S00 inverted	Black	5	6	C	C	C
S90	Green	3	8	A	A	A
S90 inverted	White	1	1	B	B	B
Sref	Brown	2	3	G	NA	G
Sref inverted	Violet	6	4	H	NA	H
+E Volt	Red	8	12	E	E	E
0 Volt	Blue	7	10	F	F	F
STATUS	Grey	NA	7	NA	NA	I
Case	Shield	Chassis	Chassis	Chassis	Chassis	Chassis
<b>Connecting direction (available on flange option -51, -63, -61)</b>						
Axial	Yes	Yes	Yes	Yes	Yes	Yes
Radial	Yes	Yes	Yes	Yes	No	Yes
<b>Connecting direction (available on flange option -52)</b>						
Axial	No	No	No	Yes	No	Yes
Radial	Yes	No	No	No	No	No

### Electrical option

Power supply	5 V ±10%	9-30 V	
Polarity protected	No	Yes	
Output signals	TTL <sup>1</sup>	HTL	RS-422
Short circuit protected	Yes	Yes	Yes
Current consumption	45 mA	50 mA at 24Vdc	25 mA at 24Vdc
Max consumption	75 mA	75 mA	40 mA
Output load (max)	±20 mA	±40 mA	±20 mA
Output frequency (max)	300 kHz	300 kHz	300 kHz
U <sub>high</sub> at 10mA load	> 3.0 V	> +EV - 2.0 V	> 3.0 V
U <sub>low</sub> at 10mA load	< 0.4 V	< 1.15 V	< 0.4 V
Cable length (max)	50 m	200 m @ 50 kHz	1 km (TIA/EIA-422-B)
STATUS output	Yes	Yes	Yes
High level	Encoder OK	Encoder OK	Encoder OK
Low level	Warning/Failure	Warning/Failure	Warning/Failure

<sup>1</sup>TTL output comply to the RS-422 standard when differential transmission is used NA=Not Available

### Output circuit

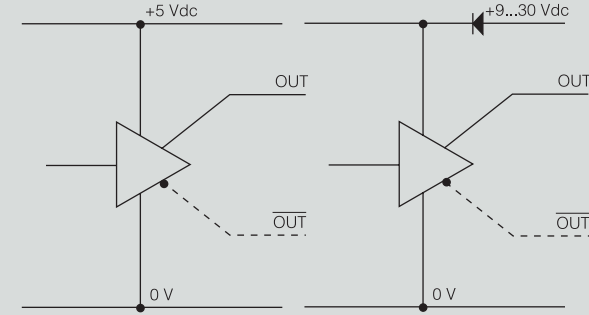

### Output signals

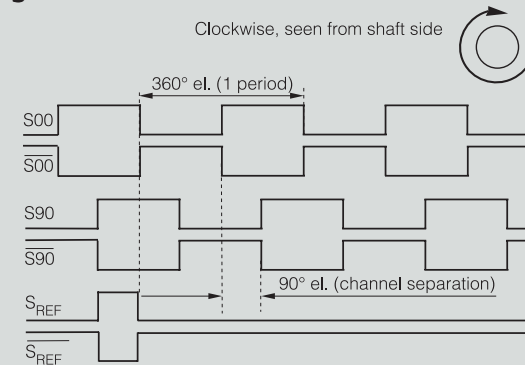

### Status outputs

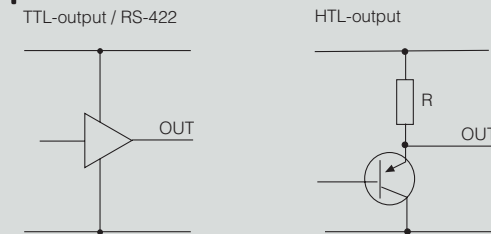



## Dimensions

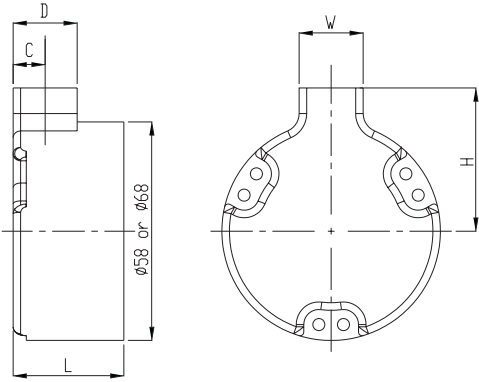

Connector	Orientation	L	H	W	D	C
Cable	Radial Ø58	29.4	34	17	17	8.5
	Radial Ø68	44.7	34	0	0	14
	Axial	38.9	-	-	-	-
EML	Radial	29.4	32	27	27	13.5
	Axial	38.9	-	-	-	-
PT 8p	Radial	29.4	41	27	27	13.5
	Axial Ø58	38.9	-	-	-	-
	Axial Ø68	44.7	-	-	-	-
MS 6p	Radial	-	-	-	-	-
	Axial	38.9	-	-	-	-
MS 10p	Radial	-	-	-	-	-
	Axial Ø58	43.9	-	-	-	-
	Axial Ø68	44.7	-	-	-	-
M12 8p	Radial	29.4	38	27	27	9.5
	Axial	38.9	-	-	-	-

## Flanges

### 51, LL58

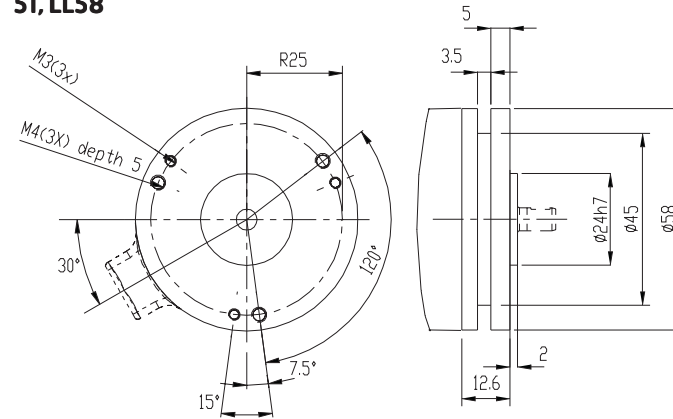

### 63, Synchro

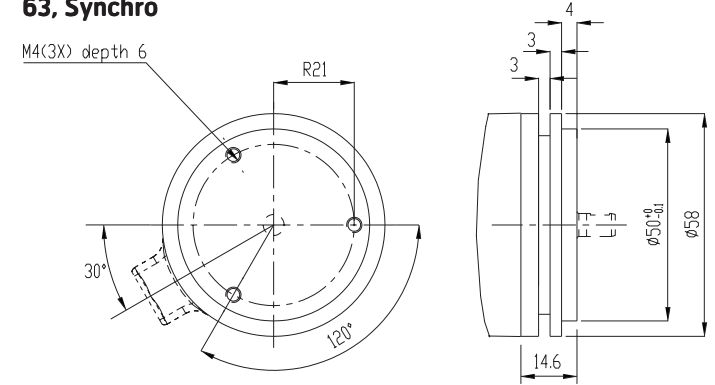

### 61, Clamping

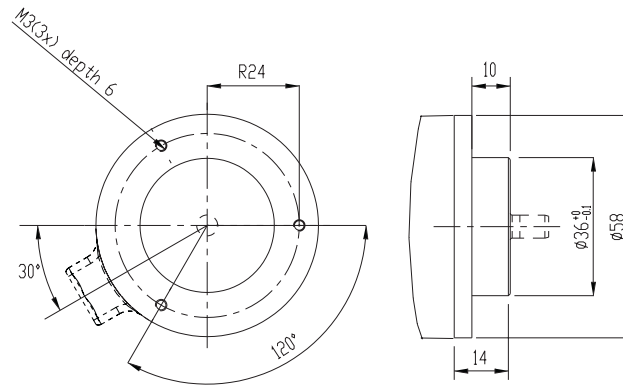

### 52, LL68

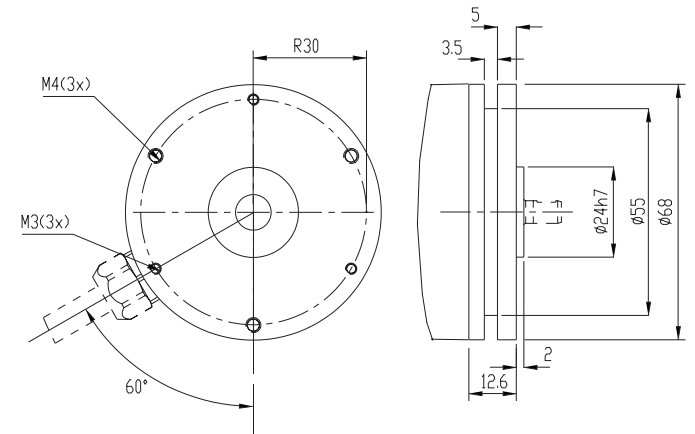



## Connectors

**Cable**  
5x2x0,25 shielded

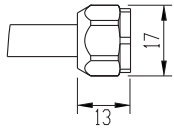

**8pin M12**

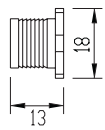

**12pin EML**

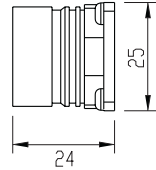

**8pin PT**

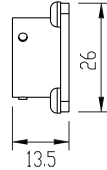

**6pin MS**

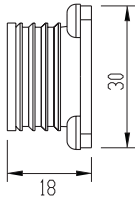

**10pin MS**

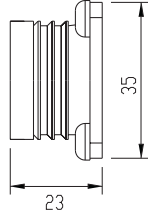

## Shafts

**6 mm with face**

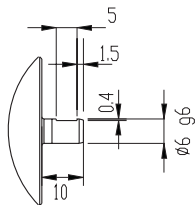

**6 mm round**

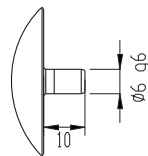

**10 mm with face**

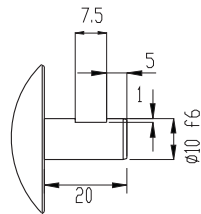

**10 mm round**

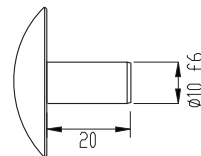

## Various combinations/examples

**RSI 504 51**

10 mm with face, axial cable

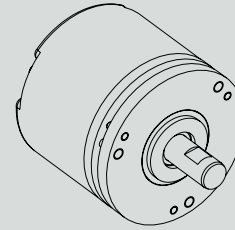

**RSI 504 63**

6 mm with face, radial PT

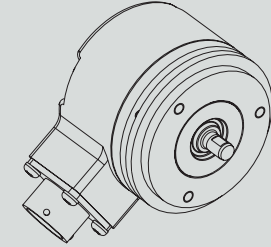

**RSI 504 61**

6 mm round, radial cable

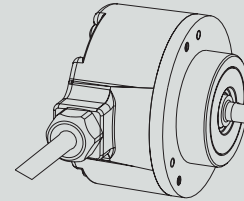

**RSI 504 52**

6 mm with face, radial cable

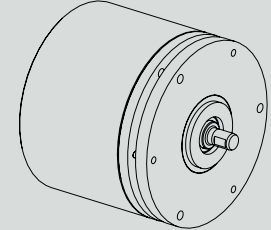

## Ordering information Tick your choice

Type	RSI 504					
Flange	51, LL58	63, Synchro	61, Clamping	52, LL68		
Shaft	Ø6 round	Ø6 with face	Ø10 round	Ø10 with face		
Electronics <sup>(1)</sup>	Supply	5Vdc	9-30Vdc			
	Output	TTL	HTL	RS-422		
Connection	Cable	8 pin M12	12 pin EML	8 pin PT	6 pin MS	10 pin MS
Connecting direction	Axial <sup>2</sup> /Radial	Axial <sup>2</sup> /Radial <sup>2</sup>	Axial <sup>2</sup> /Radial <sup>2</sup>	Axial/Radial <sup>2</sup>	Axial <sup>2</sup>	Axial/Radial <sup>2</sup>
Line count	1..5000	5001..10 000				

<sup>(1)</sup> Possible combinations: 5Vdc/TTL, 9-30Vdc/HTL or 9-30Vdc/RS-422

<sup>(2)</sup> Not available on flange option -52, LL68

**Please, specify line count and cable length when ordering**

Ordering example: RSI 504 63 Ø6ro 5Vdc 1024ppr TTL 8 pin PT Axial

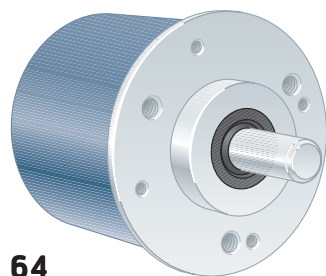

64

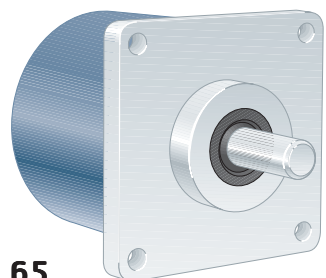

65

## Short description:

- >> 6 short-circuit protected outputs
- >> IP 67 at housing, IP 66 at shaft inlet
- >> 5 Vdc or 9...30 Vdc
- >> Robust housing for harsh environment
- >> Shock and vibration protected
- >> Imperial measurements 2,5" flanges and 3/8" shaft

## Suitable applications:

- >> Standard to demanding industrial applications

## General information

Encoder data		
Type	RSI 505	
Operating temperature	-40°C .. +70°C	
Storage temperature	-30°C .. +70°C	
Ingress protection class	IP-67 according to IEC 60529	
At shaft inlet	IP-66 according to IEC 60529	
Vibration (55 to 2000Hz)	< 300 m/s <sup>2</sup> according to IEC 60068-2-6 <sup>(1)</sup>	
Shock (6ms)	< 2000 m/s <sup>2</sup> according to IEC 60068-2-27	
Cover material	Aluminium	
Cover surface treatment	Coated and cromated or anodized	
Weight	Approx. 300g	
Accuracy and resolution		
Line count	1..5000 ppr	5001..10 000 ppr
Dividing error	± 50 °el	± 90 °el
Channel separation	90 ± 25 °el	90 ± 45 °el
Measuring steps	4 x Line count	

## Flange option

Flange type	64, Round	65, Square
Outer geometry	ø2,5" (63.5mm)	2,5" (63.5mm)
Mounting holes	3 x UNF 10x32 4 x UNC 4x40	4 x 5.2mm
Flange material	Aluminium	Aluminium
Surface treatment	Anodized	Anodized

## Shaft option

Shaft type	Ø8 round	Ø3/8" (9.52) round	Ø10 with face
Axial shaft load	50 N	50 N	50 N
Radial shaft load	60 N	60 N	60 N
Mech. permissible speed	6000 rpm (12 000)	6000 rpm (12 000)	6000 rpm (12 000)
Shaft material	Stainless steel	Stainless steel	Stainless steel
Moment of inertia	1,9 x 10 <sup>-6</sup> kgm <sup>2</sup>	1,9 x 10 <sup>-6</sup> kgm <sup>2</sup>	2,0 x 10 <sup>-6</sup> kgm <sup>2</sup>

<sup>(1)</sup><150m/s<sup>2</sup> on encoders with connectors

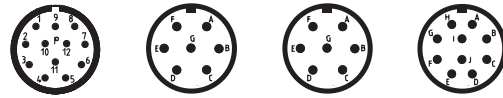

### Connection option

Connector type	Cable	12 pin EML	7 pin MS	7 pin MS sp	10 pin MS
Function	Colour	PIN	PIN	PIN	PIN
S00	Green	5	A	A	A
S00 inverted	Blue	6	NA	C	G
S90	Yellow	8	B	B	B
S90 inverted	Black	1	NA	E	H
Sref	Red	3	C	NA	C
Sref inverted	Brown	4	NA	NA	I
+E Volt	Violet	12	D	D	D
0 Volt	White	10	F	F	F
STATUS	Gray	7	NA	NA	NA
Sensor +E Volt	NA	NA	NA	NA	E
Case	Shield	Chassis	Chassis	Chassis	Chassis

### Electrical option

Power supply	5 V ±10%	9-30 V	
Polarity protected	No	Yes	
Output signals	TTL <sup>1</sup>	HTL	RS-422
Short circuit protected	Yes	Yes	Yes
Current consumption	45 mA	50 mA at 24Vdc	25 mA at 24Vdc
Max consumption	75 mA	75 mA	40 mA
Output load (max)	±20 mA	±40 mA	±20 mA
Output frequency (max)	300 kHz	300 kHz	300 kHz
U <sub>high</sub> at 10mA load	> 3.0 V	> +EV - 2.0 V	> 3.0 V
U <sub>low</sub> at 10mA load	< 0.4 V	< 1.15 V	< 0.4 V
Cable length (max)	50 m	200 m @ 50 kHz	1 km (TIA/EIA-422-B)
STATUS output	Yes	Yes	Yes
High level	Encoder OK	Encoder OK	Encoder OK
Low level	Warning/Failure	Warning/Failure	Warning/Failure

<sup>1</sup>TTL output comply to the RS-422 standard when differential transmission is used NA=Not Available

### Output circuit

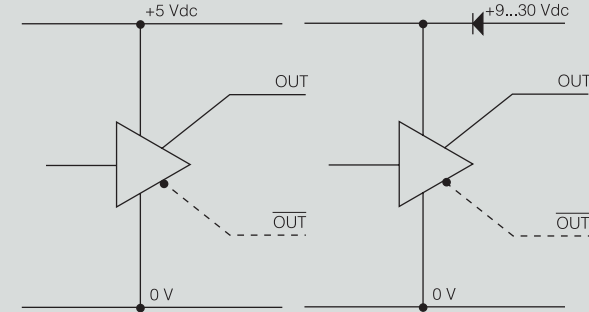

### Output signals

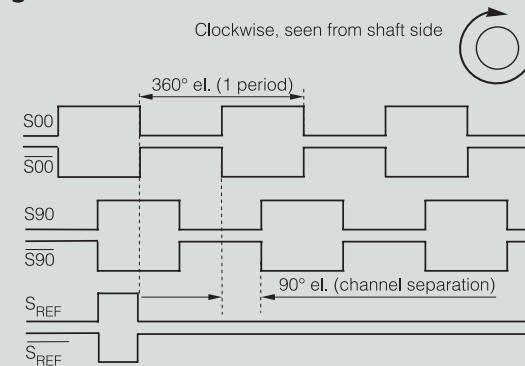

### Status outputs

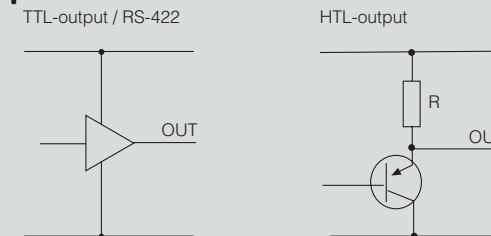

## Dimensions

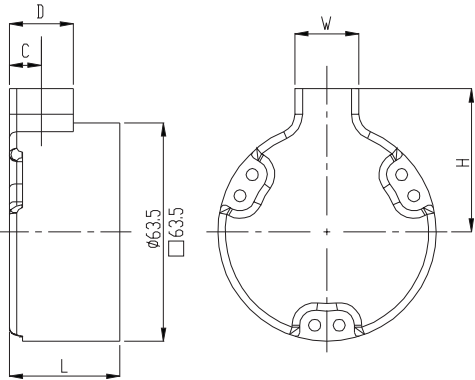

Connector	Orientation	L	H	W	D	C
Cable	Radial	29.4	34	17	17	8.5
	Axial	38.9	-	-	-	-
EML	Radial	29.4	32	27	27	13.5
	Axial	38.9	-	-	-	-
MS 7p	Radial	-	-	-	-	-
	Axial	38.9	-	-	-	-
MS 10p	Radial	-	-	-	-	-
	Axial	43.9	-	-	-	-

## Flanges

### 64, round

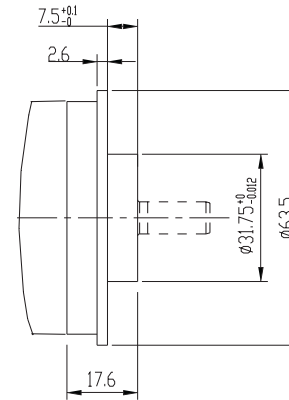
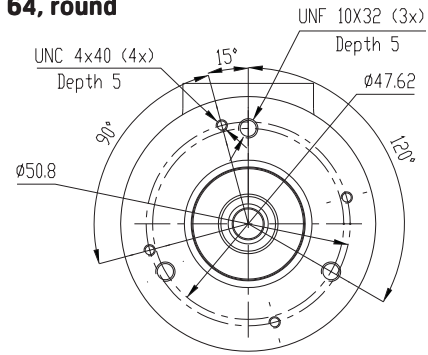

### 65, square

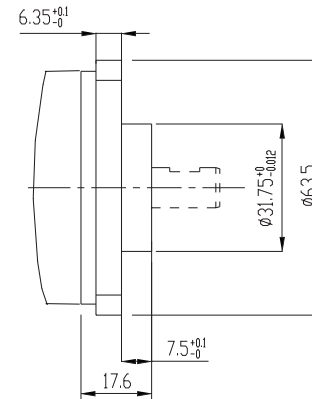
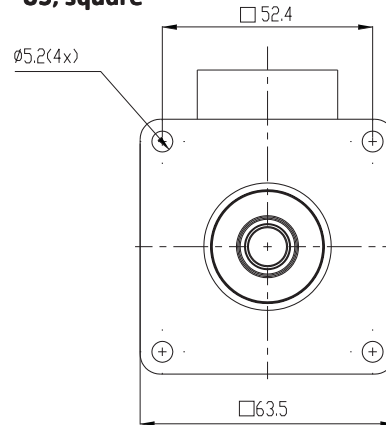

## Connectors

**Cable**  
5x2x0,25 shielded

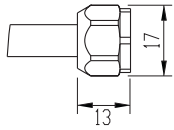

**12pin EML**

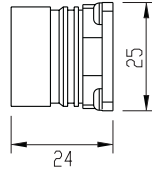

**7pin MS**

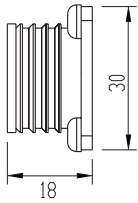

**7pin MS sp**

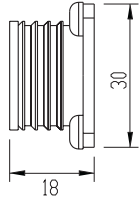

**10pin MS**

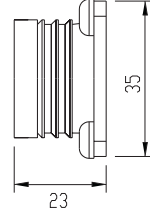

## Shafts

**8 mm round**

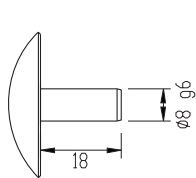

**3/8" (9.52 mm) round 10 mm with face**

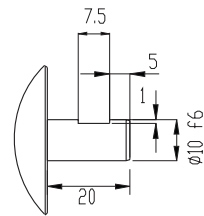
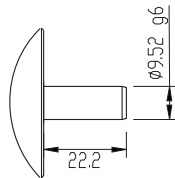

## Various combinations/examples

**RSI 505 64**

8 mm round, radial MS

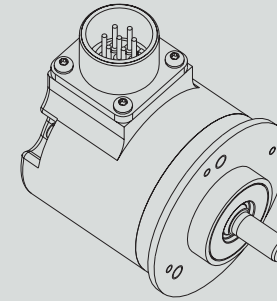

**RSI 505 65**

10 mm with face, radial MS

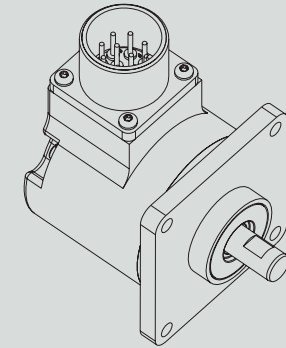

## Ordering information Tick your choice

Type	RSI 505					
Flange	64, Round	65, Square				
Shaft	Ø8 round	Ø9.52 round	Ø10 with face			
Electronics <sup>(1)</sup>	Supply	5Vdc				
	Output	TTL	HTL	RS-422		
Connection	Cable	12 pin EML	7 pin MS	7 pin MS sp	10 pin MS	
Connecting direction	Axial/Radial	Axial/Radial	Axial/Radial	Axial/Radial	Axial/Radial	
Line count	1..5000	5001..10 000				

<sup>(1)</sup> Possible combinations: 5Vdc/TTL, 9-30Vdc/HTL or 9-30Vdc/RS-422

**Please, specify line count and cable length when ordering**

Ordering example: RSI 505 65 Ø8ro 5Vdc 1024ppr TTL 12 pin EML Axial



# 507 — Ruggedized Hollow shaft encoder, Absolute

BiLL

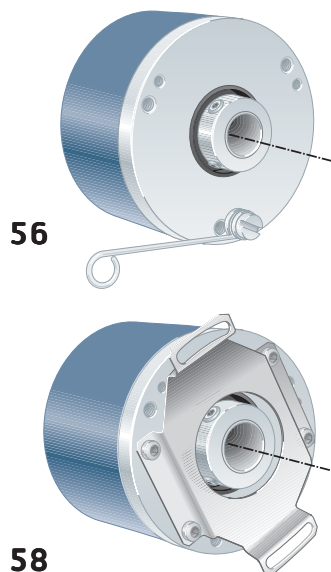

## Short description:

- >> 13 bit BiLL output
- >> IP 67 at housing, IP 66 at shaft inlet
- >> 9...36 Vdc
- >> Robust housing for harsh environment
- >> Shock and vibration protected

## Suitable applications:

- >> Standard to demanding industrial applications
- >> Positioning applications
- >> Printing machines
- >> Packaging machines

## General information

Encoder data	
Type	RHA 507
Operating temperature	-40°C .. +80°C
Storage temperature	-30°C .. +80°C
Ingress protection class	IP-67 according to IEC 60529
At shaft inlet	IP-66 according to IEC 60529
Vibration (55 to 2000Hz)	< 300 m/s <sup>2</sup> according to IEC 60068-2-6 <sup>(1)</sup>
Shock (6ms)	< 2000 m/s <sup>2</sup> according to IEC 60068-2-27
Cover material	Aluminium
Cover surface treatment	Coated and cromated or anodized
Weight	Approx. 300g
Accuracy and resolution	
Resolution	13 Bit, 8192 positions per revolution
Accuracy	± 1 LSB

## Flange option

Flange type	56, hollow-shaft	58, hollow-shaft
Type	Standard	Standard
Diameter	ø58mm	ø58mm
Flange material	Aluminium	Aluminium
Surface treatment	Anodized	Anodized
Torque support	Torque arm	Stator coupling

## Shaft option

Hollow-shaft type	Ø 8 mm	Ø 10 mm	Ø 12 mm	Ø 14 mm
Axial shaft load	10 N	10 N	10 N	10 N
Radial shaft load	20 N	20 N	20 N	20 N
Mech. permissible speed	6000 rpm (12 000)	6000 rpm (12 000)	6000 rpm (12 000)	6000 rpm (12 000)
Shaft material	Stainless steel	Stainless steel	Stainless steel	Stainless steel
Moment of inertia	1,9 x 10 <sup>-6</sup> kgm <sup>2</sup>	1,9 x 10 <sup>-6</sup> kgm <sup>2</sup>	2,0 x 10 <sup>-6</sup> kgm <sup>2</sup>	2,0 x 10 <sup>-6</sup> kgm <sup>2</sup>

<sup>(1)</sup><150m/s<sup>2</sup> on encoders with connectors



# 507 — Ruggedized Hollow shaft encoder, Absolute

BiLL

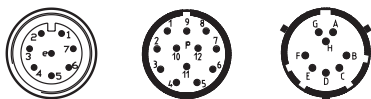

## Connection option

Connector type	Cable	8 pin M12	12 pin EML	8 pin PT
Function	Colour	PIN	PIN	PIN
Address Bit 0	White	1	1	A
Address Bit 1	Brown	2	2	B
Address Bit 2	Grey	3	3	C
Address Bit 3	Pink	4	4	D
Address 0V	Blue/Red	NA	11	NA
RS485-B	Green	5	8	G
RS485-A	Yellow	6	9	H
0V	Blue	7	10	F
+EV	Red	8	12	E
Housing	Shield	Chassis	Chassis	Chassis
Connecting direction				
Axial	Yes	Yes	Yes	Yes
Radial	Yes	Yes	Yes	Yes

NA=Not available

## Electrical option

<b>Power supply</b>	<b>9-36Vdc</b>
Polarity protected	Yes
<b>Output interface</b>	<b>RS-485 , BiLL</b>
Short circuit protected	Yes
Current consumption	100mA @ 24Vdc
Max current consumpt.	150mA
Physical interface	RS-485
Baud rate <sup>(1)</sup>	4,8-38,4 kBit/s
Node adress	Hardware adjustable
Code type	Binary
Programmable parameters	Direction, Offset, Preset Scaling parameters
Position update freq.	1kHz
Start up delay	1s

<sup>(1)</sup> Default baud rate 19,2 kBit/s

## Accessories

Accessories	Part number
Mating connector 8 pin M12	00201081 <sup>(1)</sup>
8 pin PT	00201009 <sup>(1)</sup>
12 pin EML	01209090 <sup>(1)</sup>
Torque support M6	01209143 <sup>(2)</sup>
Torque arm M6	01208014 <sup>(3)</sup>

<sup>(1)</sup> Also available with assembled cable.

<sup>(2)</sup> Only for 56 flange.

<sup>(3)</sup> Length 70-1000mm available, specify when ordering.

For additional accessories like assembled cables and torque arms please advise separate datasheets for accessories.

# 507 — Ruggedized Hollow shaft encoder, Absolute

BiLL



## Dimensions

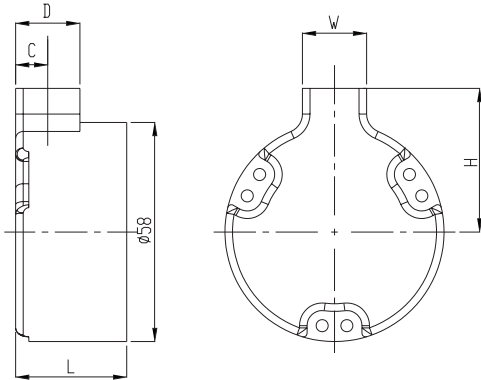

Connector	Orientation	L	H	W	D	C
Cable	Radial	29,4	34	17	17	8,5
	Axial	38,9				
EML	Radial	29,4	32	27	27	13,5
	Axial	38,9				
8p M12	Radial	29,4	38	27	27	9,5
8p PT	Radial	29,4	41	27	27	13,5
	Axial	38,9				

Note: For complete encoder dimension please add connector and flange dimensions.

## Shafts

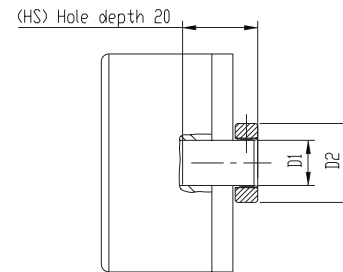

	D1	D2
ø8mm	ø8 G7	ø19
ø10mm	ø10 G7	ø19
ø12mm	ø12 G7	ø21
ø14mm	ø14 G7	ø23

## Flanges

56

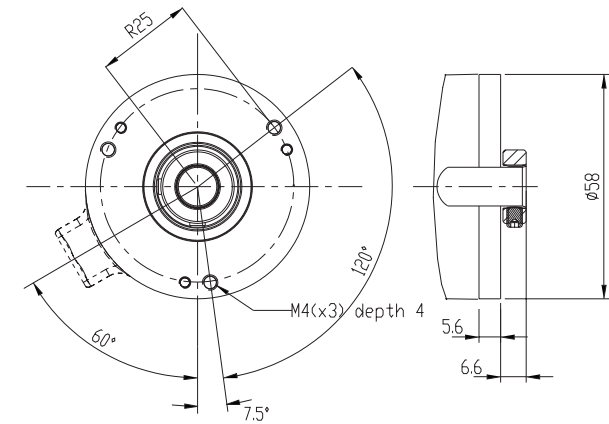

58

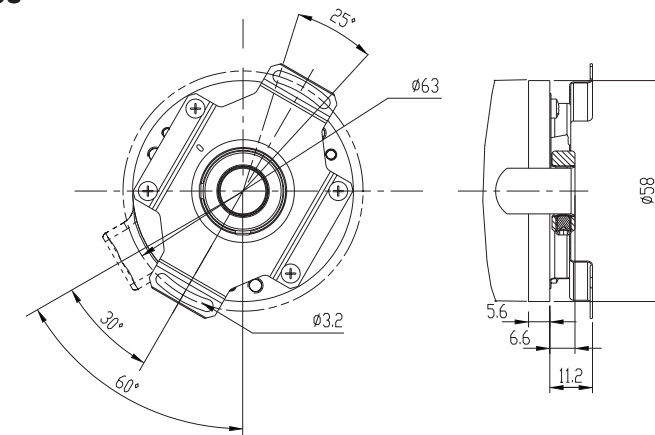



## Connectors

**Cable**  
16x0,25 shielded

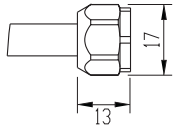

**8pin M12**

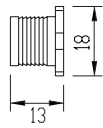

**12pin EML**

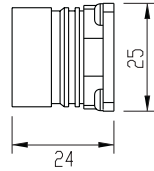

**8pin PT**

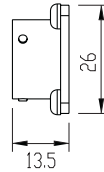

## Various combinations/examples

**RHA 507 56 12 mm , axial EML**

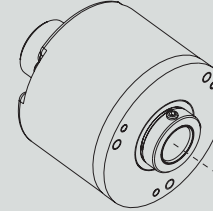

**RHA 507 56 8 mm , radial cable**

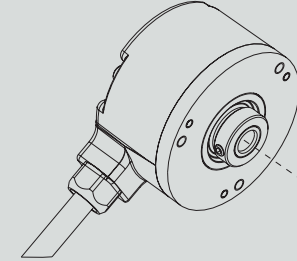

**RHA 507 58 10 mm , radial EML**

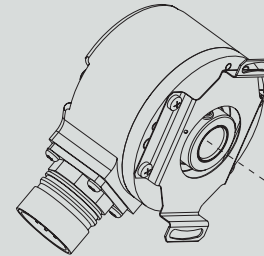

**RHA 507 58 10 mm , radial cable**

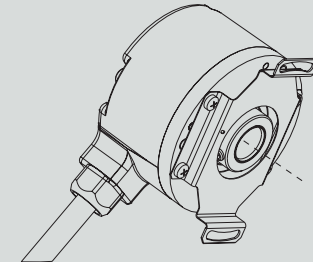

## Ordering information Tick your choice

Type	RHA 507				
Flange	56, HS	58, HS			
Shaft	Ø8mm	Ø10mm	Ø12mm	Ø14mm	
Electronics	9-36Vdc				
Supply	SBB, BiLL				
Output	SBB, BiLL				
Connection	Cable <sup>(1)</sup>	8 pin M12	12 pin EML	8 pin PT	
Connecting direction	Axial/Radial	Axial/Radial	Axial/Radial	Axial/Radial	
Resolution	13 bit				

<sup>(1)</sup> Note: Please specify cable length when ordering

Ordering example: RHA 507 56 ø10 9-36Vdc SBB 12 pin EML Radial 13bit  
Assembly drawing is available upon request from Leine & Linde AB

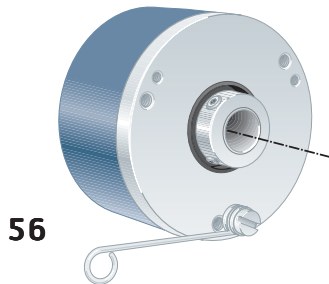

56

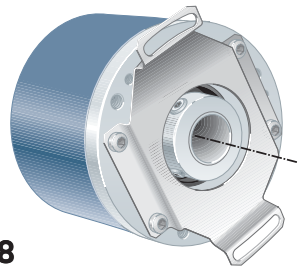

58

## Short description:

- >> 13 bit CANopen output
- >> IP 67 at housing, IP 66 at shaft inlet
- >> 9...36 Vdc
- >> Robust housing for harsh environment
- >> Shock and vibration protected

## Suitable applications:

- >> Standard to demanding industrial applications
- >> Positioning applications
- >> Printing machines
- >> Packaging machines

## General information

Encoder data	
Type	RHA 507
Operating temperature	-40°C .. +80°C
Storage temperature	-30°C .. +80°C
Ingress protection class	IP-67 according to IEC 60529
At shaft inlet	IP-66 according to IEC 60529
Vibration (55 to 2000Hz)	< 300 m/s <sup>2</sup> according to IEC 60068-2-6 <sup>(1)</sup>
Shock (6ms)	< 2000 m/s <sup>2</sup> according to IEC 60068-2-27
Cover material	Aluminium
Cover surface treatment	Coated and cromated or anodized
Weight	Approx. 300g
Accuracy and resolution	
Resolution	13 Bit, 8192 positions per revolution
Accuracy	± 1 LSB

## Flange option

Flange type	56, hollow-shaft	58, hollow-shaft
Type	Standard	Standard
Diameter	ø58mm	ø58mm
Flange material	Aluminium	Aluminium
Surface treatment	Anodized	Anodized
Torque support	Torque arm	Stator coupling

## Shaft option

Hollow-shaft type	Ø 8 mm	Ø 10 mm	Ø 12 mm	Ø 14 mm
Axial shaft load	10 N	10 N	10 N	10 N
Radial shaft load	20 N	20 N	20 N	20 N
Mech. permissible speed	6000 rpm (12 000)	6000 rpm (12 000)	6000 rpm (12 000)	6000 rpm (12 000)
Shaft material	Stainless steel	Stainless steel	Stainless steel	Stainless steel
Moment of inertia	1,9 x 10 <sup>-6</sup> kgm <sup>2</sup>	1,9 x 10 <sup>-6</sup> kgm <sup>2</sup>	2,0 x 10 <sup>-6</sup> kgm <sup>2</sup>	2,0 x 10 <sup>-6</sup> kgm <sup>2</sup>

<sup>(1)</sup><150m/s<sup>2</sup> on encoders with connectors

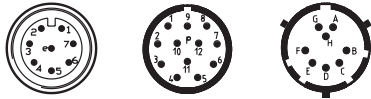

### Connection option

Connector type	Cable	8 pin M12	12 pin EML	8 pin PT
Function	Colour	PIN	PIN	PIN
Address Bit 0	White	1	1	A
Address Bit 1	Brown	2	2	B
Address Bit 2	Grey	3	3	C
Address Bit 3	Pink	4	4	D
Address 0V	Blue/Red	NA	11	NA
CAN_H	Green	5	8	G
CAN_L	Yellow	6	9	H
0V	Blue	7	10	F
+EV	Red	8	12	E
Housing	Shield	Chassis	Chassis	Chassis
Connecting direction				
Axial	Yes	Yes	Yes	Yes
Radial	Yes	Yes	Yes	Yes

NA=Not available

### Electrical option

<b>Power supply</b>	<b>9-36Vdc</b>
Polarity protected	Yes
<b>Output interface</b>	<b>CANopen</b>
Short circuit protected	Yes
Current consumption	100mA @ 24Vdc
Max current consumpt.	150mA
Physical interface	CAN according to ISO-11898
Supported profile	Device profile for encoders DS406 v2.0
Baud rate <sup>(1)</sup>	Max. 1Mbit/s software adjustable
Node adress	Hardware or software adjustable
Code type	Binary
Supported functions	Code sequence, Preset, Scaling and Node Guarding
Position update freq.	1kHz
Start up delay	700ms

<sup>(1)</sup> Default baudrate 125 kBit/s

### Accessories

Accessories	Part number
Configuration file EDS file	619208-01
Mating connector 8 pin M12	00201081 <sup>(1)</sup>
8 pin PT	00201009 <sup>(1)</sup>
12 pin EML	01209090 <sup>(1)</sup>
Torque support M6	01209143 <sup>(2)</sup>
Torque arm M6	01208014 <sup>(3)</sup>

<sup>(1)</sup> Also available with assembled cable.

<sup>(2)</sup> Only for 56 flange.

<sup>(3)</sup> Length 70-1000mm available, specify when ordering.

For additional accessories like assembled cables and torque arms please advise separate datasheets for accessories.



## Dimensions

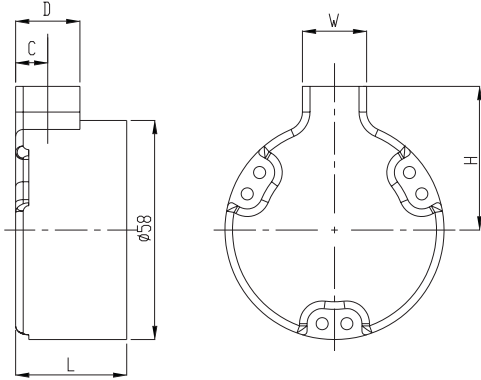

Connector	Orientation	L	H	W	D	C
Cable	Radial	29,4	34	17	17	8,5
	Axial	38,9				
EML	Radial	29,4	32	27	27	13,5
	Axial	38,9				
8p M12	Radial	29,4	38	27	27	9,5
	Axial	38,9				
8p PT	Radial	29,4	41	27	27	13,5
	Axial	38,9				

Note: For complete encoder dimension please add connector and flange dimensions.

## Shafts

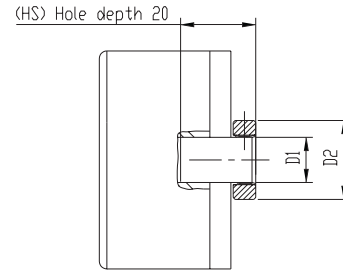

	D1	D2
ø8mm	ø8 G7	ø19
ø10mm	ø10 G7	ø19
ø12mm	ø12 G7	ø21
ø14mm	ø14 G7	ø23

## Flanges

56

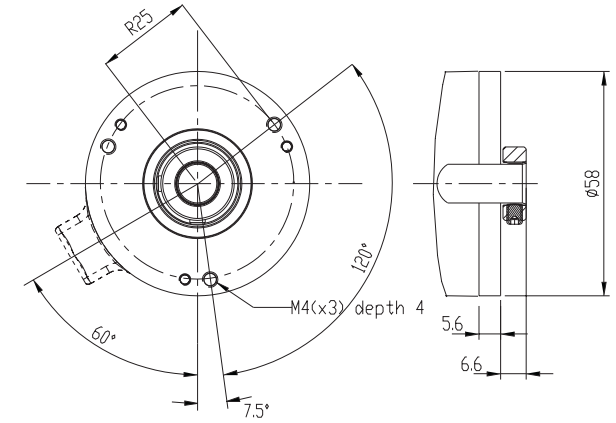

58

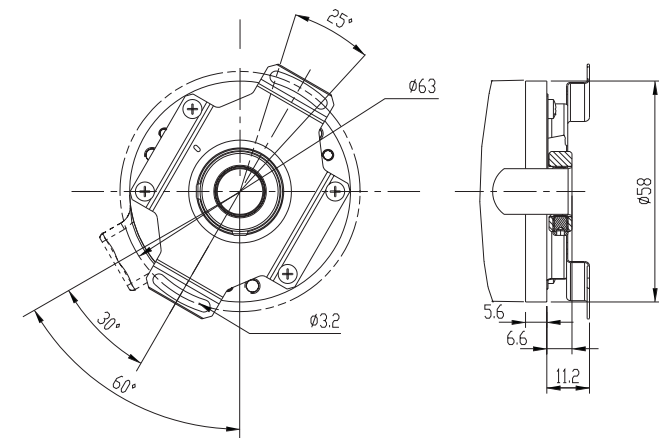



## Connectors

**Cable**  
12x0,25 shielded

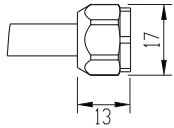

**8pin M12**

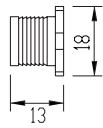

**12pin EML**

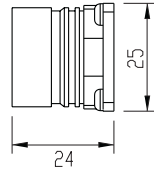

**8pin PT**

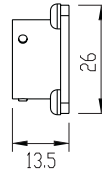

## Various combinations/examples

**RHA 507 56 12 mm , axial EML**

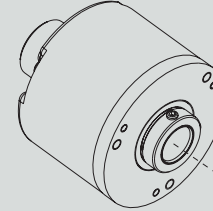

**RHA 507 56 8 mm , radial cable**

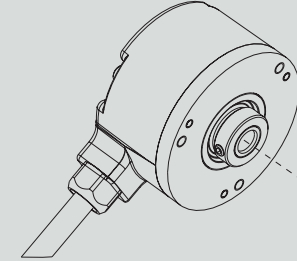

**RHA 507 58 10 mm , radial EML**

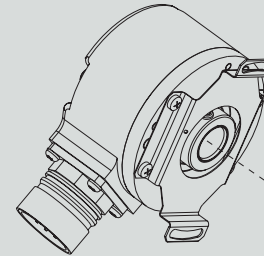

**RHA 507 58 10 mm , radial cable**

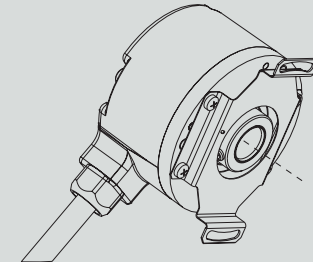

## Ordering information Tick your choice

Type	RHA 507				
Flange	56, HS	58, HS			
Shaft	Ø8mm	Ø10mm	Ø12mm	Ø14mm	
Electronics	Supply	9-36Vdc			
	Output	SCO, CANopen			
Connection	Cable <sup>(1)</sup>	8 pin M12	12 pin EML	8 pin PT	
Connecting direction	Axial/Radial	Axial/Radial	Axial/Radial	Axial/Radial	
Resolution	13 bit				

<sup>(1)</sup> Note: Please specify cable length when ordering

Ordering example: RHA 507 56 ø10 9-36Vdc SCO 8 pin M12 Radial 13bit  
Assembly drawing is available upon request from Leine & Linde AB



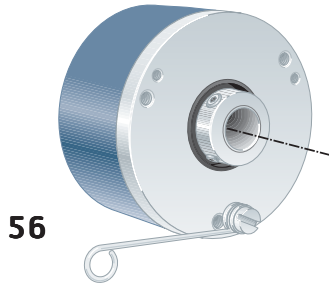

56

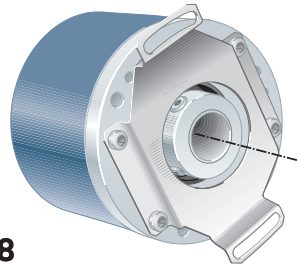

58

#### Short description:

- >> 13 bit Parallel output
- >> Binary or Gray coded
- >> 5 Vdc or 9...36 Vdc
- >> IP 67 at housing, IP 66 at shaft inlet
- >> Robust housing for harsh environment
- >> Shock and vibration protected

#### Suitable applications:

- >> Standard to demanding industrial applications
- >> Positioning applications
- >> Printing machines
- >> Packaging machines

#### General information

Encoder data	
Type	RHA 507
Operating temperature	-40°C .. +80°C
Storage temperature	-30°C .. +80°C
Ingress protection class	IP-67 according to IEC 60529
At shaft inlet	IP-66 according to IEC 60529
Vibration (55 to 2000Hz)	< 300 m/s <sup>2</sup> according to IEC 60068-2-6 <sup>(1)</sup>
Shock (6ms)	< 2000 m/s <sup>2</sup> according to IEC 60068-2-27
Cover material	Aluminium
Cover surface treatment	Coated and cromated or anodized
Weight	Approx. 300g
Accuracy and resolution	
Resolution	≤ 13 Bit, 8192 positions per revolution
Accuracy	± 1 LSB

#### Flange option

Flange type	56, hollow-shaft	58, hollow-shaft
Type	Standard	Standard
Diameter	ø58mm	ø58mm
Flange material	Aluminium	Aluminium
Surface treatment	Anodized	Anodized
Torque support	Torque arm	Stator coupling

#### Shaft option

Hollow-shaft type	Ø 8 mm	Ø 10 mm	Ø 12 mm	Ø 14 mm
Axial shaft load	10 N	10 N	10 N	10 N
Radial shaft load	20 N	20 N	20 N	20 N
Mech. permissible speed	6000 rpm (12 000)	6000 rpm (12 000)	6000 rpm (12 000)	6000 rpm (12 000)
Shaft material	Stainless steel	Stainless steel	Stainless steel	Stainless steel
Moment of inertia	1,9 x 10 <sup>-6</sup> kgm <sup>2</sup>	1,9 x 10 <sup>-6</sup> kgm <sup>2</sup>	2,0 x 10 <sup>-6</sup> kgm <sup>2</sup>	2,0 x 10 <sup>-6</sup> kgm <sup>2</sup>

<sup>(1)</sup><150m/s<sup>2</sup> on encoders with connectors



### Connection option

Connector type	Cable	19 pin PT
Function	Colour	PIN
Bit 1 (LSB)	Brown/Yellow	R
Bit 2	Brown/Green	P
Bit 3	White/Green	N
Bit 4	Blue/Red	M
Bit 5	Grey/Pink	L
Bit 6	Violet	K
Bit 7	Black	J
Bit 8	Pink	H
Bit 9	Grey	G
Bit 10	Yellow	D
Bit 11	Green	C
Bit 12	Brown	B
Bit 13 (MSB)	White	A
Code sequence	White/Yellow	V
0V	Blue	F
+EV	Red	E
Housing	Shield	Chassis
Connecting direction		
Axial	Yes	Yes
Radial	Yes	No

Note: If 12 bit resolution is required the LSB shall not be connected

### Electrical option

Power supply	5Vdc ± 10%	9-36Vdc
Polarity protected	No	Yes
Output interface	Parallel	
Short circuit protected	Yes	
Current consumption	100mA	50mA @24Vdc
Max current consumpt.	150mA	110mA
Output load	±20mA	±20mA
Output frequency	0...200 kHz	
U <sub>high</sub> at 10mA load	> 3.0V	> EV-3.0V
U <sub>low</sub> at 10mA load	< 0.4V	< 0.5V
Cable length (max)	10m	100m
Code type	Binary or Gray	
Position update freq.	16MHz	
Start up delay	25ms	
Input		
Code sequence	If not connected or connected to 0V the position will increase when the shaft is turned clockwise. If connected to a high logic level the position will increase while turned counter clockwise.	
U <sub>high</sub>	> 2V	> EV x 0.6
U <sub>low</sub>	< 0.8V	< EV x 0.25
Delay	75µs	

### Accessories

Accessories		Part number
Mating connector	19 pin PT	00201010 <sup>(1)</sup>
Torque support	M6	01209143 <sup>(2)</sup>
Torque arm	M6	01208014 <sup>(3)</sup>

<sup>(1)</sup> Also available with assembled cable.

<sup>(2)</sup> Only for 56 flange.

<sup>(3)</sup> Length 70-1000mm available, specify when ordering.

For additional accessories like assembled cables and torque arms please advise separate datasheets for accessories.



## Dimensions

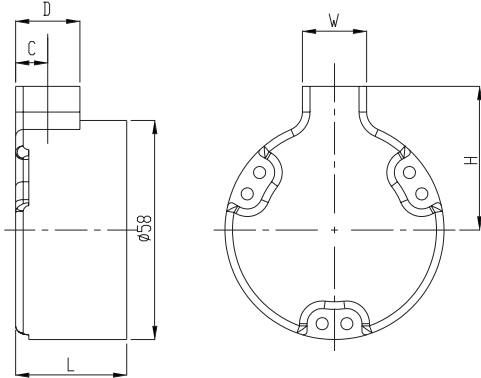

Connector	Orientation	L	H	W	D	C
Cable	Radial	29,4	34	17	17	8,5
	Axial	38,9				
19p PT	Radial	48,4	31,5	30	30	15
	Axial	38,9				

Note: For complete encoder dimension please add connector and flange dimensions.

## Shafts

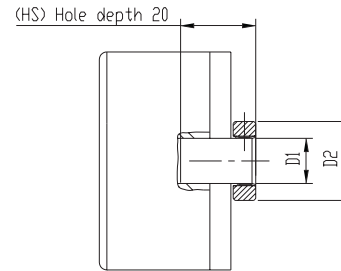

	D1	D2
ø8mm	ø8 G7	ø19
ø10mm	ø10 G7	ø19
ø12mm	ø12 G7	ø21
ø14mm	ø14 G7	ø23

## Flanges

56

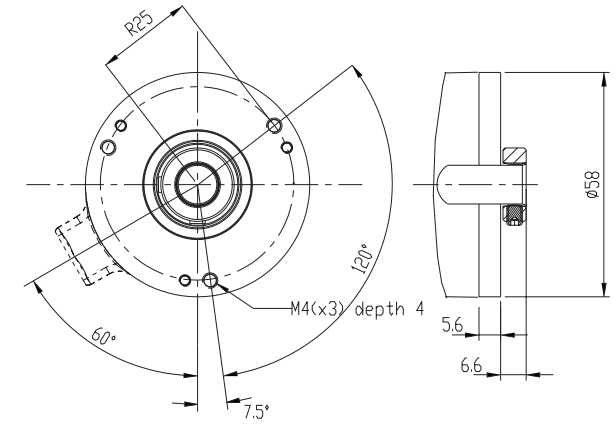

58

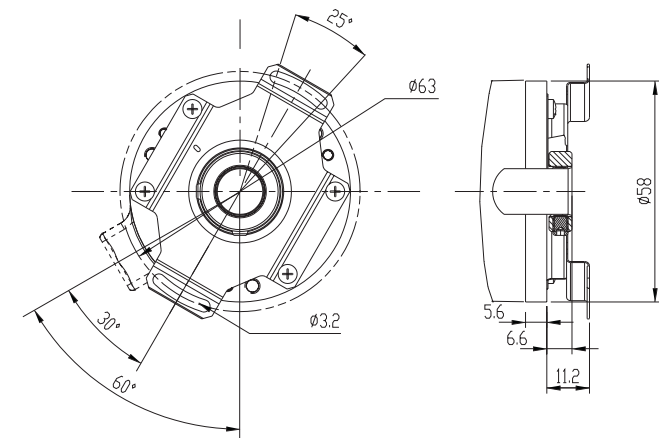

# 507

## Ruggedized Hollow shaft encoder, Absolute

PARALLEL



### Connectors

**Cable**  
16x0,25 shielded

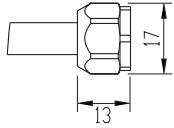

**19pin PT**

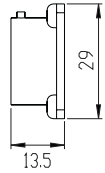

### Various combinations/examples

**RHA 507 56**  
12 mm , axial PT

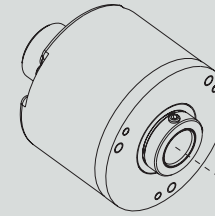

**RHA 507 58**  
10 mm , radial cable

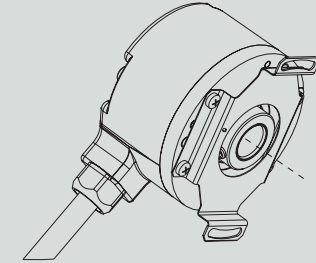

### Ordering information Tick your choice

Type	RHA 507			
Flange	56, HS	58, HS		
Shaft	Ø8mm	Ø10mm	Ø12mm	Ø14mm
Electronics	Supply	5 Vdc	9-36Vdc	
	Output	PLG, Gray	PLB, Binary	
Connection	Cable <sup>(1)</sup>		19 pin PT <sup>(2)</sup>	
Connecting direction	Axial <sup>(2)</sup> /Radial		Axial	
Resolution	13 bit			

<sup>(1)</sup> Note: Please specify cable length when ordering

<sup>(2)</sup> Note: Not available on flange 52, LL68

Ordering example: RHA 507 56 ø10 9-36Vdc PLB Cable Radial 13bit  
Assembly drawing is available upon request from Leine & Linde AB

# 507 — Ruggedized Hollow shaft encoder, Absolute SSI

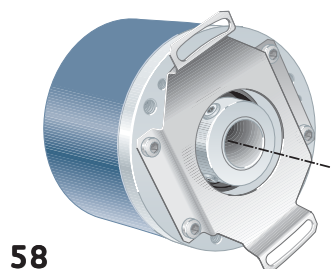
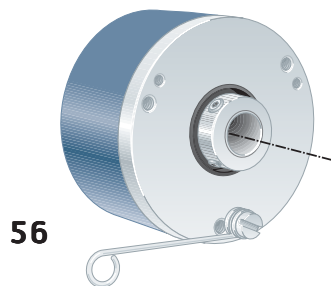

## Short description:

- >> 13 bit SSI output
- >> Binary or Gray coded
- >> 5 Vdc or 9...36 Vdc
- >> IP 67 at housing, IP 66 at shaft inlet
- >> Robust housing for harsh environment
- >> Shock and vibration protected

## Suitable applications:

- >> Standard to demanding industrial applications
- >> Positioning applications
- >> Printing machines
- >> Packaging machines

## General information

Encoder data	
Type	RHA 507
Operating temperature	-40°C .. +80°C
Storage temperature	-30°C .. +80°C
Ingress protection class	IP-67 according to IEC 60529
At shaft inlet	IP-66 according to IEC 60529
Vibration (55 to 2000Hz)	< 300 m/s <sup>2</sup> according to IEC 60068-2-6 <sup>(1)</sup>
Shock (6ms)	< 2000 m/s <sup>2</sup> according to IEC 60068-2-27
Cover material	Aluminium
Cover surface treatment	Coated and cromated or anodized
Weight	Approx. 300g
Accuracy and resolution	
Resolution	13 Bit, 8192 positions per revolution
Accuracy	± 1 LSB

## Flange option

Flange type	56, hollow-shaft	58, hollow-shaft
Type	Standard	Standard
Diameter	ø58mm	ø58mm
Flange material	Aluminium	Aluminium
Surface treatment	Anodized	Anodized
Torque support	Torque arm	Stator coupling

## Shaft option

Hollow-shaft type	Ø 8 mm	Ø 10 mm	Ø 12 mm	Ø 14 mm
Axial shaft load	10 N	10 N	10 N	10 N
Radial shaft load	20 N	20 N	20 N	20 N
Mech. permissible speed	6000 rpm (12 000)	6000 rpm (12 000)	6000 rpm (12 000)	6000 rpm (12 000)
Shaft material	Stainless steel	Stainless steel	Stainless steel	Stainless steel
Moment of inertia	1,9 x 10 <sup>-6</sup> kgm <sup>2</sup>	1,9 x 10 <sup>-6</sup> kgm <sup>2</sup>	2,0 x 10 <sup>-6</sup> kgm <sup>2</sup>	2,0 x 10 <sup>-6</sup> kgm <sup>2</sup>

<sup>(1)</sup><150m/s<sup>2</sup> on encoders with connectors



### Connection option

Connector type	Cable	8pM12	17 pin EML	8 pin PT
Function	Colour	PIN	PIN	PIN
Clock +	Yellow	3	8	A
Clock -	Green	4	9	B
Data +	White	5	14	C
Data -	Black	6	17	D
Code Sequence	Violet	8	2	H
Hold	Brown	NA	NA	G
0V	Blue	1	10	F
+EV	Red	2	7	E
Housing	Shield	Chassis	Chassis	Chassis
Connecting direction				
Axial	Yes	Yes	Yes	Yes
Radial	Yes	Yes	Yes	Yes

### Electrical option

Power supply	5Vdc ±10%	9-36Vdc
Polarity protected	No	Yes
Output interface	SSI	
Short circuit protected	Yes	
Current consumption	100mA	50mA @ 24Vdc
Max current consumpt.	150mA	110mA
Output circuitry	RS-422	
Output frequency	100kHz...1MHz	
Cable length (max)	Frequency dependent	
Code type	Binary or Gray	
Position update freq.	16MHz	
Start up delay	25ms	
Input 1 (Code sequence)		
Code sequence	If not connected or connected to 0V the position will increase when the shaft is turned clockwise.	
U <sub>high</sub>	> 2V	> EV x 0.6
U <sub>low</sub>	< 0.7V	< EV x 0.25
Delay	75µs	
Input 2 (Hold)		
Hold	When connected to +EV or a logic high level will the position not be changed when the shaft is turned.	
U <sub>high</sub>	> 2V	> EV x 0.6
U <sub>low</sub>	< 0.7V	< EV x 0.25
Delay	75µs	

### Accessories

Accessories	Part number
Mating connector 8 pin M12	00201081 <sup>(1)</sup>
8 pin PT	00201009 <sup>(1)</sup>
17 pin EML	01209085 <sup>(1)</sup>
Torque support M6	01209143 <sup>(2)</sup>
Torque arm M6	01208014 <sup>(3)</sup>

<sup>(1)</sup> Also available with assembled cable.

<sup>(2)</sup> Only for 56 flange.

<sup>(3)</sup> Length 70-1000mm available, specify when ordering.

For additional accessories like assembled cables and torque arms please advise separate datasheets for accessories.

# 507 — Ruggedized Hollow shaft encoder, Absolute

SSI



## Dimensions

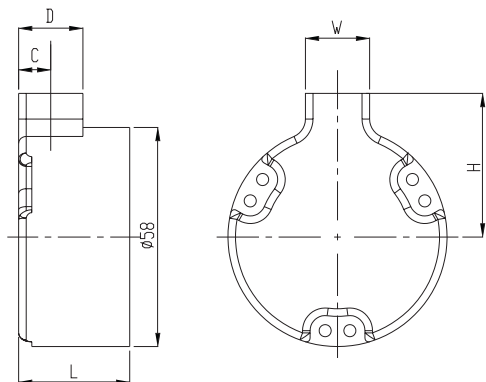

Connector	Orientation	L	H	W	D	C
Cable	Radial	29,4	34	17	17	8,5
	Axial	38,9				
EML	Radial	29,4	32	27	27	13,5
	Axial	38,9				
8p M12	Radial	29,4	38	27	27	9,5
	Axial	38,9				
8p PT	Radial	29,4	41	27	27	13,5
	Axial	38,9				

Note: For complete encoder dimension please add connector and flange dimensions.

## Shafts

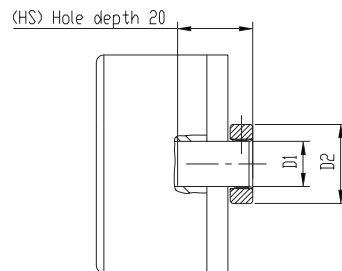

	D1	D2
ø8mm	ø8 G7	ø19
ø10mm	ø10 G7	ø19
ø12mm	ø12 G7	ø21
ø14mm	ø14 G7	ø23

## Flanges

56

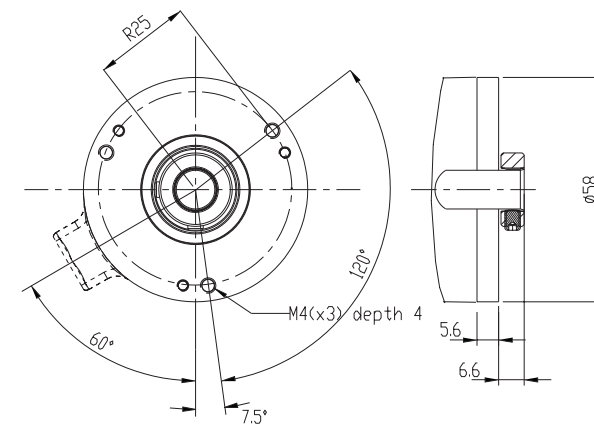

58

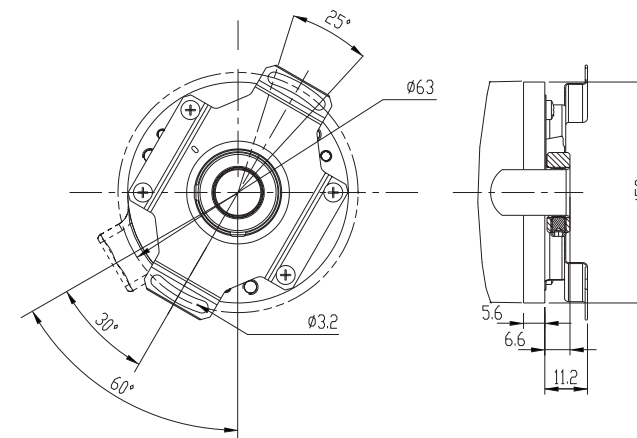



## Connectors

**Cable**  
16x0,25 shielded

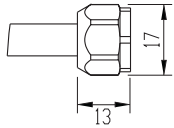

**8pin M12**

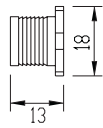

**17pin EML**

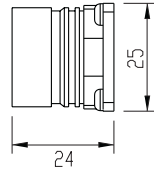

**8pin PT**

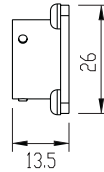

## Various combinations/examples

**RHA 507 56 12 mm , axial EML**

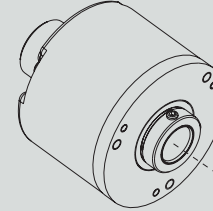

**RHA 507 56 8 mm , radial cable**

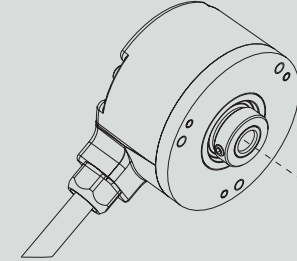

**RHA 507 58 10 mm , radial EML**

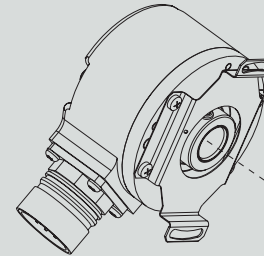

**RHA 507 58 10 mm , radial cable**

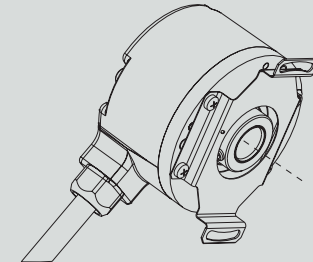

## Ordering information Tick your choice

Type	RHA 507				
Flange	56, HS	58, HS			
Shaft	Ø8mm	Ø10mm	Ø12mm	Ø14mm	
Electronics	Supply	5Vdc	9-36Vdc		
	Output	SSG, Gray	SSB, Binary		
Connection	Cable <sup>(1)</sup>	8 pin M12	17 pin EML	8 pin PT	
Connecting direction	Axial/Radial	Radial/Axial	Radial/Axial	Radial/Axial	
Resolution	13 bit				

<sup>(1)</sup> Note: Please specify cable length when ordering

Ordering example: RHA 507 56 ø10 9-36Vdc SSG Cable Radial 13bit  
Assembly drawing is available upon request from Leine & Linde AB



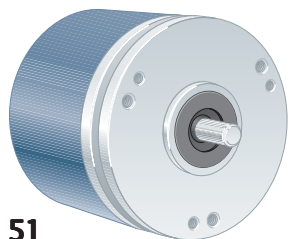

51

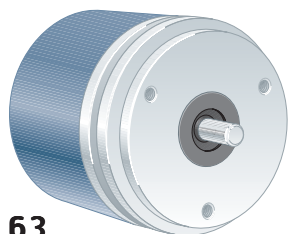

63

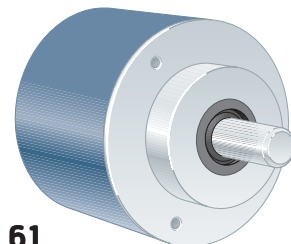

61

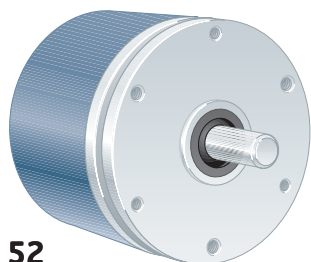

52

### Short description:

- >> 13 bit BiLL output
- >> IP 67 at housing, IP 66 at shaft inlet
- >> 9...36 Vdc
- >> Robust housing for harsh environment
- >> Shock and vibration protected

### Suitable applications:

- >> Standard to demanding industrial applications
- >> Positioning applications
- >> Printing machines
- >> Packaging machines

### General information

Encoder data	
Type	RSA 507
Operating temperature	-40°C .. +80°C
Storage temperature	-30°C .. +80°C
Ingress protection class	IP-67 according to IEC 60529
At shaft inlet	IP-66 according to IEC 60529
Vibration (55 to 2000Hz)	< 300 m/s <sup>2</sup> according to IEC 60068-2-6 <sup>(1)</sup>
Shock (6ms)	< 2000 m/s <sup>2</sup> according to IEC 60068-2-27
Cover material	Aluminium
Cover surface treatment	Coated and cromated or anodized
Weight	Approx. 300g
Accuracy and resolution	
Resolution	13 Bit, 8192 positions per revolution (Scaleable)
Accuracy	± 1 LSB

### Flange option

Flange type	51, LL58	63, Synchro	61, Clamping	52, LL68
Outer diameter	ø58 mm	ø58 mm	ø58 mm	ø68 mm
Mounting holes	3 x M3 & 3 x M4	3 x M4	3 x M3	3 x M3 & 3 x M4
Flange material	Aluminium	Aluminium	Aluminium	Aluminium
Surface treatment	Anodized	Anodized	Anodized	Anodized

### Shaft option

Shaft type	Ø 6 round	Ø 6 with face	Ø 10 round	Ø 10 with face
Axial shaft load	50 N	50 N	50 N	50 N
Radial shaft load	60 N	60 N	60 N	60 N
Mech. permissible speed	6000 rpm (12 000)	6000 rpm (12 000)	6000 rpm (12 000)	6000 rpm (12 000)
Shaft material	Stainless steel	Stainless steel	Stainless steel	Stainless steel
Moment of inertia	1,9 x 10 <sup>-6</sup> kgm <sup>2</sup>	1,9 x 10 <sup>-6</sup> kgm <sup>2</sup>	2,0 x 10 <sup>-6</sup> kgm <sup>2</sup>	2,0 x 10 <sup>-6</sup> kgm <sup>2</sup>

<sup>(1)</sup><150m/s<sup>2</sup> on encoders with connectors



### Connection option

Connector type	Cable	8 pin M12	12 pin EML	8 pin PT
Function	Colour	PIN	PIN	PIN
Adress Bit 0	White	1	1	A
Adress Bit 1	Brown	2	2	B
Adress Bit 2	Grey	3	3	C
Adress Bit 3	Pink	4	4	D
Adress 0V	Blue/Red	NA	11	NA
RS485-B	Green	5	8	G
RS485-A	Yellow	6	9	H
0V	Blue	7	10	F
+EV	Red	8	12	E
Housing	Shield	Chassis	Chassis	Chassis
<b>Connecting direction (available on flange option -51, -63, -61)</b>				
Axial	Yes	Yes	Yes	Yes
Radial	Yes	Yes	Yes	Yes
<b>Connecting direction (available on flange option -52)</b>				
Axial	No	No	No	Yes
Radial	Yes	No	No	No

NA=Not available

### Electrical option

Power supply	9-36Vdc
Polarity protected	Yes
Output interface	RS-485 , BiLL
Short circuit protected	Yes
Current consumption	100mA @ 24Vdc
Max current consumpt.	150mA
Physical interface	RS-485
Baud rate <sup>(1)</sup>	4,8-38,4 kBit/s
Node adress	Hardware adjustable
Code type	Binary
Programmable parameters	Direction, Offset, Preset Scaling parameters
Position update freq.	1kHz
Start up delay	1s

<sup>(1)</sup> Default baud rate 19,2 kBit/s

### Accessories

Accessories	Part number	
Mating connector 8 pin M12	00201081 <sup>(1)</sup>	
8 pin PT	00201009 <sup>(1)</sup>	
12 pin EML	01209090 <sup>(1)</sup>	
Coupling	6-6 mm	464192222 <sup>(2)</sup>
	10-10 mm	464333232 <sup>(2)</sup>
Mounting bracket	00208011 <sup>(3)</sup>	
Bearing box	01209010 <sup>(4)</sup>	

<sup>(1)</sup> Also available with assembled cable.

<sup>(2)</sup> Other couplings are also available.

<sup>(3)</sup> Only for 63 Synchro and 61 Clamping flanges.

<sup>(4)</sup> Only for 63 Synchro flange.

For additional accessories like assembled cables, mounting clamps, measuring wheels, draw wire box etc.

Please, advise separate datasheets for accessories.



## Dimensions

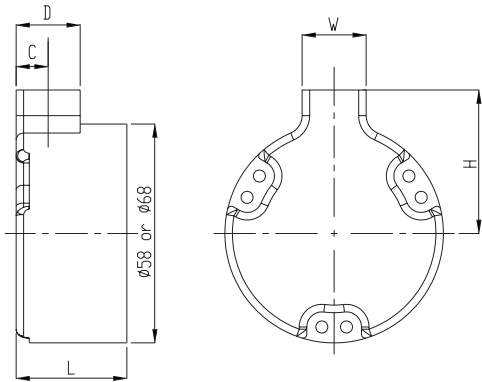

Connector	Orientation	L	H	W	D	C
Cable	Radial Ø58	29,4	34	17	17	8,5
	Radial Ø68	44,7	34	0	0	14
	Axial	38,9				
EML	Radial	29,4	32	27	27	13,5
	Axial	38,9				
8p M12	Radial	29,4	38	27	27	9,5
	Axial	38,9				
8p PT	Radial	29,4	41	27	27	13,5
	Axial Ø58	38,9				
	Axial Ø68	44,7				

Note: For complete encoder dimension please add connector and flange dimensions.

## Flanges

### 51, LL58

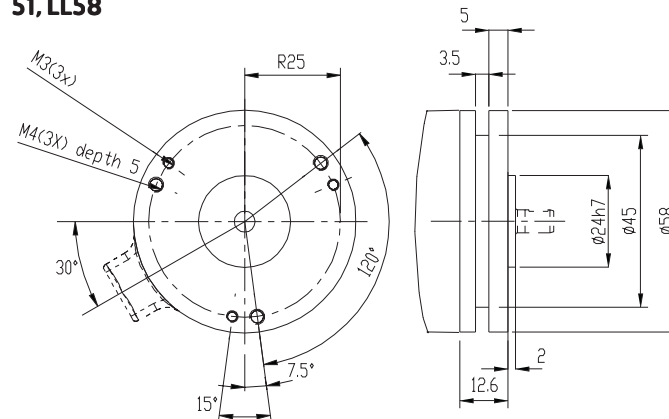

### 61, Clamping

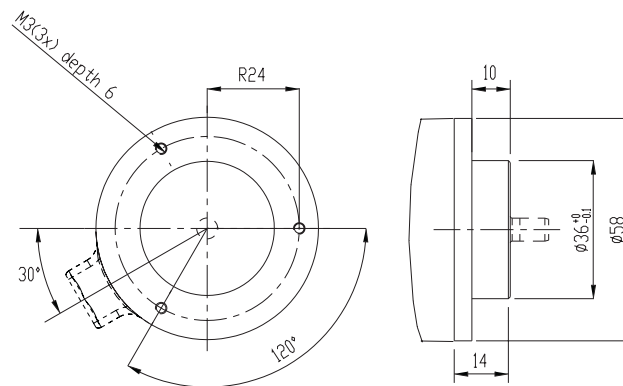

### 63, Synchro

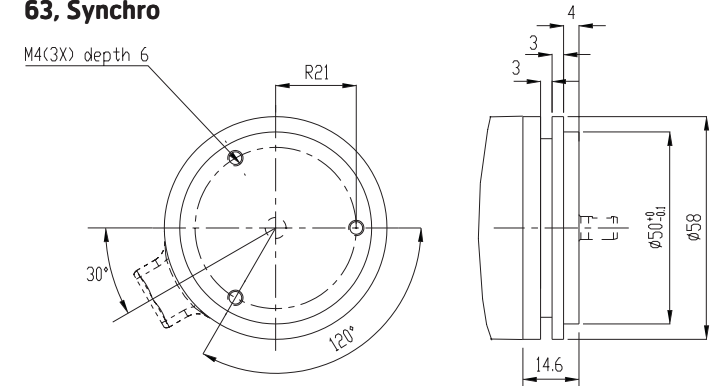

### 52, LL68

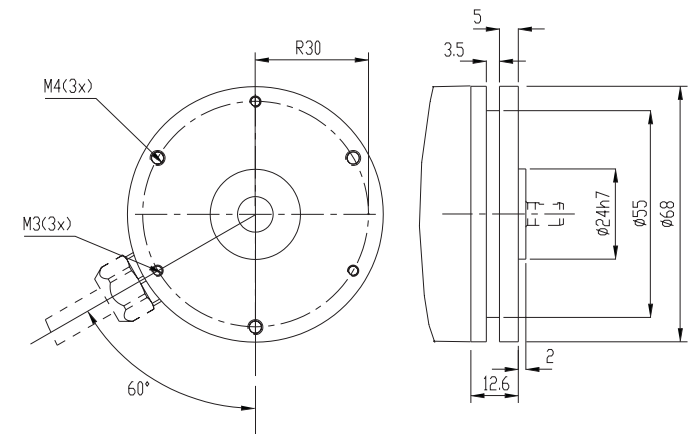



## Connectors

**Cable**  
16x0,25 shielded

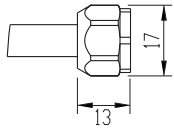

**8pin M12**

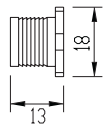

**12pin EML**

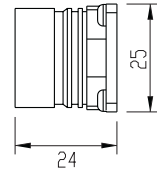

**8pin PT**

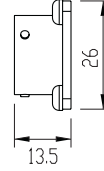

## Shafts

**6 mm with face**

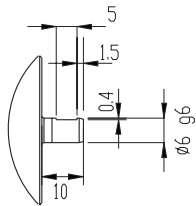

**6 mm round**

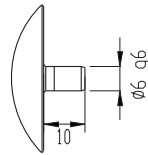

**10 mm with face**

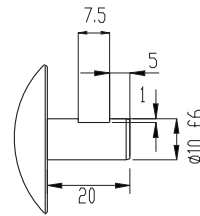

**10 mm round**

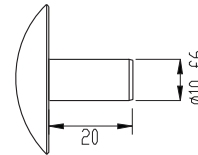

## Various combinations/examples

**RSA 507 51**

10 mm with face, axial M12

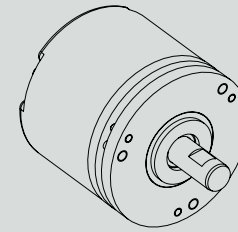

**RSA 507 63**

6 mm with face, radial PT

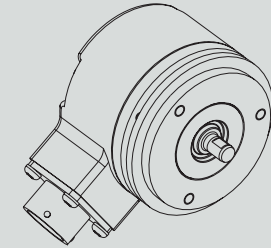

**RSA 507 61**

6 mm round, radial cable

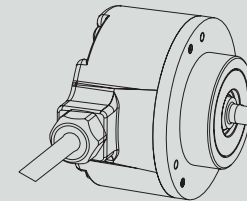

**RSA 507 52**

6 mm with face, axial M12

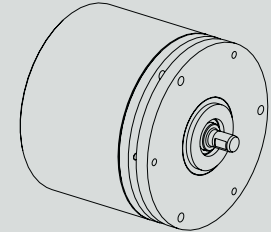

## Ordering information Tick your choice

Type	RSA 507			
Flange	51, LL58	63, Synchro	61, Clamping	52, LL68
Shaft	Ø6mm round	Ø6mm with face	Ø10mm round	Ø10mm with face
Electronics	Supply 9-36Vdc			
	Output SBB, BiLL			
Connection	Cable <sup>(1)</sup>	8 pin M12	12 pin EML	8 pin PT
Connecting direction	Axial/Radial	Axial/Radial	Axial/Radial	Axial/Radial
Resolution	13 bit			

<sup>(1)</sup> Note: Please specify cable length when ordering

Ordering example: RSA 507 63 ø10ro 9-36Vdc SBB 12 pin EML Radial 13bit  
Assembly drawing is available upon request from Leine & Linde AB

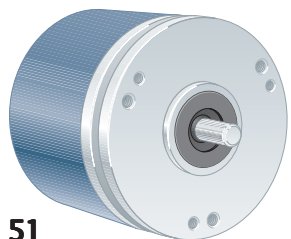

51

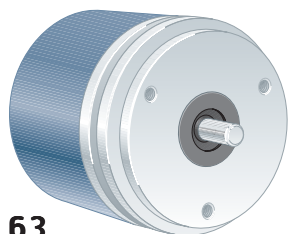

63

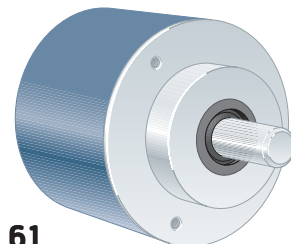

61

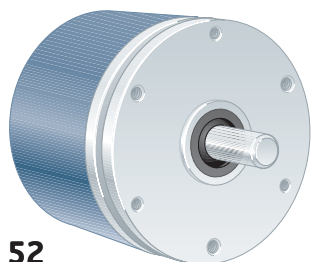

52

## Short description:

- >> 13 bit CANopen output
- >> IP 67 at housing, IP 66 at shaft inlet
- >> 9...36 Vdc
- >> Robust housing for harsh environment
- >> Shock and vibration protected

## Suitable applications:

- >> Standard to demanding industrial applications
- >> Positioning applications
- >> Printing machines
- >> Packaging machines

## General information

Encoder data	
Type	RSA 507
Operating temperature	-40°C .. +80°C
Storage temperature	-30°C .. +80°C
Ingress protection class	IP-67 according to IEC 60529
At shaft inlet	IP-66 according to IEC 60529
Vibration (55 to 2000Hz)	< 300 m/s <sup>2</sup> according to IEC 60068-2-6 <sup>(1)</sup>
Shock (6ms)	< 2000 m/s <sup>2</sup> according to IEC 60068-2-27
Cover material	Aluminium
Cover surface treatment	Coated and cromated or anodized
Weight	Approx. 300g
Accuracy and resolution	
Resolution	13 Bit, 8192 positions per revolution (Scaleable)
Accuracy	± 1 LSB

## Flange option

Flange type	51, LL58	63, Synchro	61, Clamping	52, LL68
Outer diameter	ø58 mm	ø58 mm	ø58 mm	ø68 mm
Mounting holes	3 x M3 & 3 x M4	3 x M4	3 x M3	3 x M3 & 3 x M4
Flange material	Aluminium	Aluminium	Aluminium	Aluminium
Surface treatment	Anodized	Anodized	Anodized	Anodized

## Shaft option

Shaft type	Ø 6 round	Ø 6 with face	Ø 10 round	Ø 10 with face
Axial shaft load	50 N	50 N	50 N	50 N
Radial shaft load	60 N	60 N	60 N	60 N
Mech. permissible speed	6000 rpm (12 000)	6000 rpm (12 000)	6000 rpm (12 000)	6000 rpm (12 000)
Shaft material	Stainless steel	Stainless steel	Stainless steel	Stainless steel
Moment of inertia	1,9 x 10 <sup>-6</sup> kgm <sup>2</sup>	1,9 x 10 <sup>-6</sup> kgm <sup>2</sup>	2,0 x 10 <sup>-6</sup> kgm <sup>2</sup>	2,0 x 10 <sup>-6</sup> kgm <sup>2</sup>

<sup>(1)</sup><150m/s<sup>2</sup> on encoders with connectors



### Connection option

Connector type	Cable	8 pin M12	12 pin EML	8 pin PT
Function	Colour	PIN	PIN	PIN
Adress Bit 0	White	1	1	A
Adress Bit 1	Brown	2	2	B
Adress Bit 2	Grey	3	3	C
Adress Bit 3	Pink	4	4	D
Adress 0V	Blue/Red	NA	11	NA
CAN_H	Green	5	8	G
CAN_L	Yellow	6	9	H
0V	Blue	7	10	F
+EV	Red	8	12	E
Housing	Shield	Chassis	Chassis	Chassis
<b>Connecting direction (available on flange option -51, -63, -61)</b>				
Axial	Yes	Yes	Yes	Yes
Radial	Yes	Yes	Yes	Yes
<b>Connecting direction (available on flange option -52)</b>				
Axial	No	No	No	Yes
Radial	Yes	No	No	No

NA=Not available

### Electrical option

<b>Power supply</b>	<b>9-36Vdc</b>
Polarity protected	Yes
<b>Output interface</b>	<b>CANopen</b>
Short circuit protected	Yes
Current consumption	100mA @ 24Vdc
Max current consumpt.	150mA
Physical interface	CAN according to ISO-11898
Supported profile	Device profile for encoders DS406 v2.0
Baud rate <sup>(1)</sup>	Max. 1Mbit/s software adjustable
Node adress	Hardware or software adjustable
Code type	Binary
Supported functions	Code sequence, Preset, Scaling and Node Guarding
Position update freq.	1kHz
Start up delay	700ms

<sup>(1)</sup> Default baud rate 125 kBit/s

### Accessories

Accessories	Part number
Configuration file EDS file	619208-01
Mating connector 8 pin M12 8 pin PT 12 pin EML	00201081 <sup>(1)</sup>
	00201009 <sup>(1)</sup>
	01209090 <sup>(1)</sup>
Coupling 6-6 mm 10-10 mm	464192222 <sup>(2)</sup>
	464333232 <sup>(2)</sup>
Mounting bracket	00208011 <sup>(3)</sup>
Bearing box	01209010 <sup>(4)</sup>

<sup>(1)</sup> Also available with assembled cable.

<sup>(2)</sup> Other couplings are also available.

<sup>(3)</sup> Only for 63 Synchro and 61 Clamping flanges.

<sup>(4)</sup> Only for 63 Synchro flange.

For additional accessories like assembled cables, mounting clamps, measuring wheels, draw wire box etc.

Please advise separate datasheets for accessories.



## Dimensions

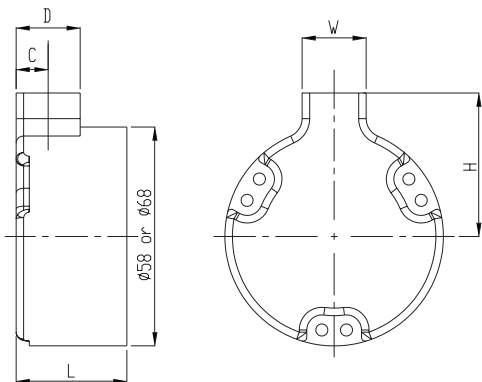

Connector	Orientation	L	H	W	D	C
Cable	Radial Ø58	29,4	34	17	17	8,5
	Radial Ø68	44,7	34	0	0	14
	Axial	38,9				
EML	Radial	29,4	32	27	27	13,5
	Axial	38,9				
8p M12	Radial	29,4	38	27	27	9,5
	Axial	38,9				
8p PT	Radial	29,4	41	27	27	13,5
	Axial Ø58	38,9				
	Axial Ø68	44,7				

Note: For complete encoder dimension please add connector and flange dimensions.

## Flanges

### 51, LL58

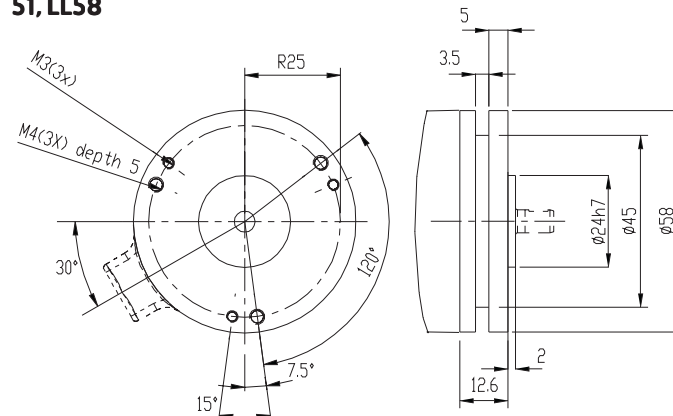

### 61, Clamping

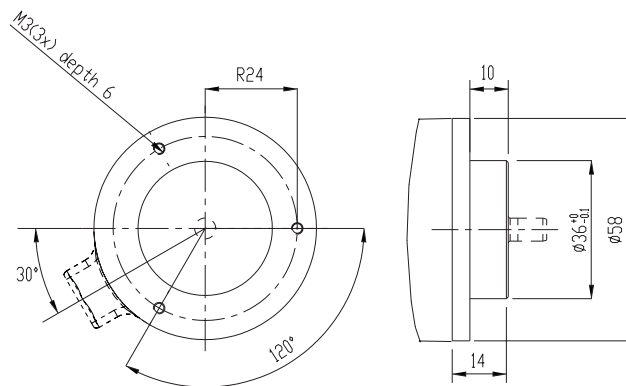

### 63, Synchro

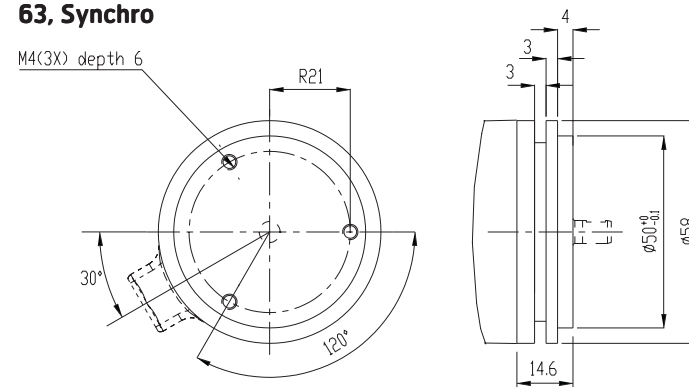

### 52, LL68

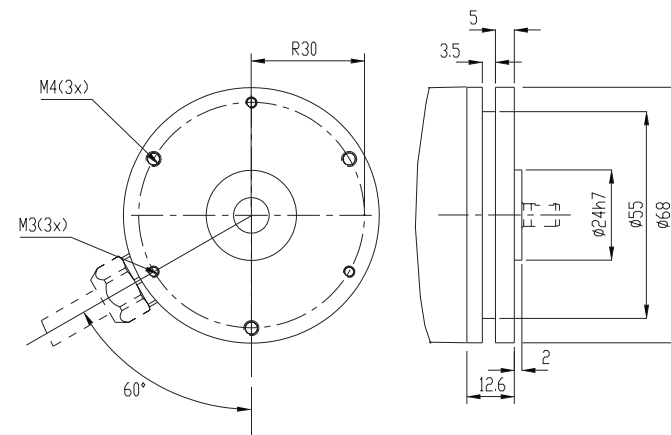



## Connectors

**Cable**  
12x0,25 shielded

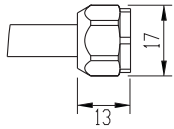

**8pin M12**

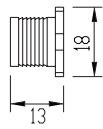

**12pin EML**

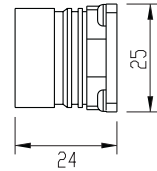

**8pin PT**

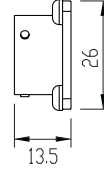

## Shafts

**6 mm with face**

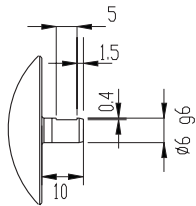

**6 mm round**

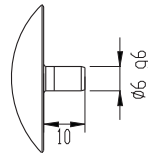

**10 mm with face**

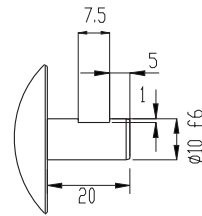

**10 mm round**

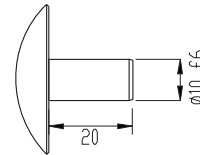

## Various combinations/examples

**RSA 507 51**

10 mm with face, axial M12

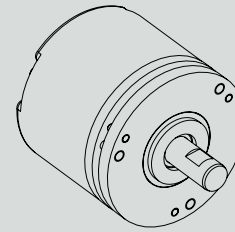

**RSA 507 63**

6 mm with face, radial PT

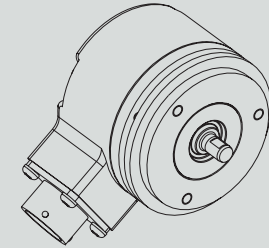

**RSA 507 61**

6 mm round, radial cable

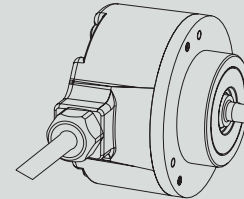

**RSA 507 52**

6 mm with face, axial M12

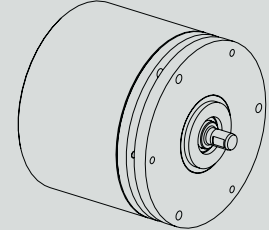

## Ordering information Tick your choice

Type	RSA 507				
Flange	51, LL58	63, Synchro	61, Clamping	52, LL68	
Shaft	Ø6mm round	Ø6mm with face	Ø10mm round	Ø10mm with face	
Electronics	Supply	9-36Vdc			
	Output	SCO, CANopen			
Connection	Cable <sup>(1)</sup>	8 pin M12	12 pin EML	8 pin PT	
Connecting direction	Axial/Radial	Axial/Radial	Axial/Radial	Axial/Radial	
Resolution	13 bit				

<sup>(1)</sup> Note: Please specify cable length when ordering

Ordering example: RSA 507 63 Ø10r0 9-36Vdc SCO 12 pin EML Radial 13bit  
Assembly drawing is available upon request from Leine & Linde AB



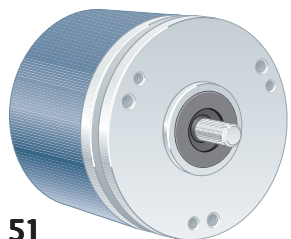

51

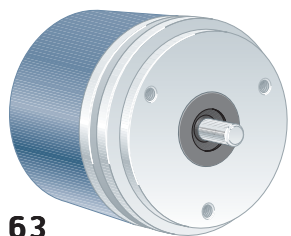

63

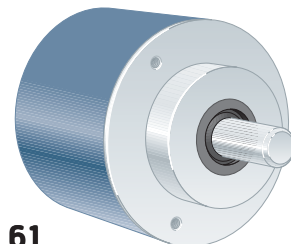

61

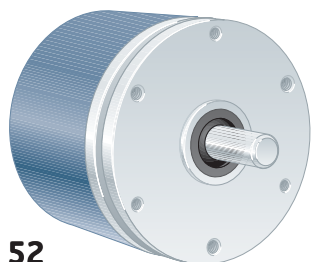

52

## Short description:

- >> 13 bit Parallel output
- >> Binary or Gray coded
- >> 5 Vdc or 9...36 Vdc
- >> IP 67 at housing, IP 66 at shaft inlet
- >> Robust housing for harsh environment
- >> Shock and vibration protected

## Suitable applications:

- >> Standard to demanding industrial applications
- >> Positioning applications
- >> Printing machines
- >> Packaging machines

## General information

Encoder data	
Type	RSA 507
Operating temperature	-40°C .. +80°C
Storage temperature	-30°C .. +80°C
Ingress protection class	IP-67 according to IEC 60529
At shaft inlet	IP-66 according to IEC 60529
Vibration (55 to 2000Hz)	< 300 m/s <sup>2</sup> according to IEC 60068-2-6 <sup>(1)</sup>
Shock (6ms)	< 2000 m/s <sup>2</sup> according to IEC 60068-2-27
Cover material	Aluminium
Cover surface treatment	Coated and cromated or anodized
Weight	Approx. 300g
Accuracy and resolution	
Resolution	≤ 13 Bit, 8192 positions per revolution
Accuracy	± 1 LSB

## Flange option

Flange type	51, LL58	63, Synchro	61, Clamping	52, LL68
Outer diameter	ø58 mm	ø58 mm	ø58 mm	ø68 mm
Mounting holes	3 x M3 & 3 x M4	3 x M4	3 x M3	3 x M3 & 3 x M4
Flange material	Aluminium	Aluminium	Aluminium	Aluminium
Surface treatment	Anodized	Anodized	Anodized	Anodized

## Shaft option

Shaft type	Ø 6 round	Ø 6 with face	Ø 10 round	Ø 10 with face
Axial shaft load	50 N	50 N	50 N	50 N
Radial shaft load	60 N	60 N	60 N	60 N
Mech. permissible speed	6000 rpm (12 000)	6000 rpm (12 000)	6000 rpm (12 000)	6000 rpm (12 000)
Shaft material	Stainless steel	Stainless steel	Stainless steel	Stainless steel
Moment of inertia	1,9 x 10 <sup>-6</sup> kgm <sup>2</sup>	1,9 x 10 <sup>-6</sup> kgm <sup>2</sup>	2,0 x 10 <sup>-6</sup> kgm <sup>2</sup>	2,0 x 10 <sup>-6</sup> kgm <sup>2</sup>

<sup>(1)</sup><150m/s<sup>2</sup> on encoders with connectors





### Connection option

Connector type	Cable	19 pin PT
Function	Colour	PIN
Bit 1 (LSB)	Brown/Yellow	R
Bit 2	Brown/Green	P
Bit 3	White/Green	N
Bit 4	Blue/Red	M
Bit 5	Grey/Pink	L
Bit 6	Violet	K
Bit 7	Black	J
Bit 8	Pink	H
Bit 9	Grey	G
Bit 10	Yellow	D
Bit 11	Green	C
Bit 12	Brown	B
Bit 13 (MSB)	White	A
Code sequence	White/Yellow	V
0V	Blue	F
+EV	Red	E
Housing	Shield	Chassis
<b>Connecting direction (flange option -51, -61, -63)</b>		
Axial	Yes	Yes
Radial	Yes	No
<b>Connecting direction (flange option -52)</b>		
Axial	No	No
Radial	Yes	No

Note: If 12 bit resolution is required the LSB shall not be connected

### Electrical option

Power supply	5Vdc ± 10%	9-36Vdc
Polarity protected	No	Yes
<b>Output interface Parallel</b>		
Short circuit protected	Yes	
Current consumption	100mA	50mA @24Vdc
Max current consumpt.	150mA	110mA
Output load	±20mA	±20mA
Output frequency	0...200 kHz	
U <sub>high</sub> at 10mA load	> 3.0V	> EV-3.0V
U <sub>low</sub> at 10mA load	< 0.4V	< 0.5V
Cable length (max)	10m	100m
Code type	Binary or Gray	
Position update freq.	16MHz	
Start up delay	25ms	
<b>Input</b>		
Code sequence	If not connected or connected to 0V the position will increase when the shaft is turned clockwise. If connected to a high logic level the position will increase while turned counter clockwise.	
U <sub>high</sub>	> 2V	> EV x 0.6
U <sub>low</sub>	< 0.8V	< EV x 0.25
Delay	75µs	

### Accessories

Accessories		Part number
Mating connector	19 pin PT	00201010 <sup>(1)</sup>
Coupling	6-6 mm	464192222 <sup>(2)</sup>
	10-10 mm	464333232 <sup>(2)</sup>
Mounting bracket		00208011 <sup>(3)</sup>
Bearing box		01209010 <sup>(4)</sup>

<sup>(1)</sup> Also available with assembled cable.

<sup>(2)</sup> Other couplings are also available.

<sup>(3)</sup> Only for 63 Synchro and 61 Clamping flanges.

<sup>(4)</sup> Only for 63 Synchro flange.

For additional accessories like assembled cables, mounting clamps, measuring wheels, draw wire box etc. Please, advise separate datasheets for accessories.





## Connectors

**Cable**  
16x0,25 shielded

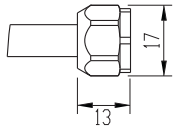

**19pin PT**

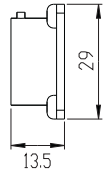

## Shafts

**6 mm with face**

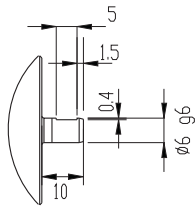

**6 mm round**

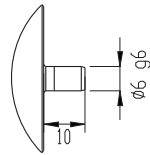

**10 mm with face**

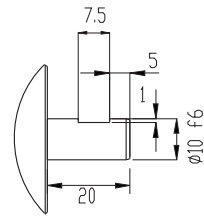

**10 mm round**

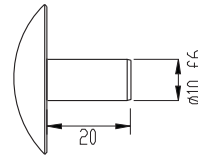

## Various combinations/examples

**RSA 507 51**

10 mm with face, axial PT

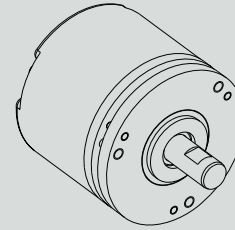

**RSA 507 61**

6 mm round, radial cable

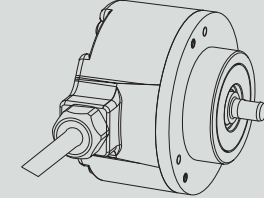

**RSA 507 52**

6 mm with face, axial PT

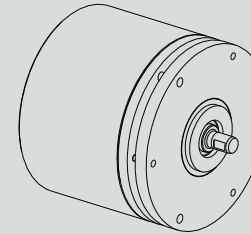

## Ordering information Tick your choice

Type	RSA 507				
Flange	51, LL58	63, Synchro	61, Clamping	52, LL68	
Shaft	Ø6mm round	Ø6mm with face	Ø10mm round	Ø10mm with face	
Electronics	Supply	5 Vdc	9-36Vdc		
	Output	PLG, Gray	PLB, Binary		
Connection	Cable <sup>(1)</sup>	19 pin PT <sup>(2)</sup>			
Connecting direction	Axial <sup>(2)</sup> /Radial	Axial			
Resolution	13 bit				

<sup>(1)</sup> Note: Please specify cable length when ordering

<sup>(2)</sup> Note: Not available on flange 52, LL68

Ordering example: RSA 507 63 Ø10ro 9-36Vdc PLB Cable Radial 13bit  
Assembly drawing is available upon request from Leine & Linde AB

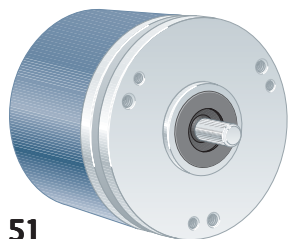

51

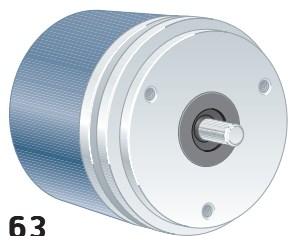

63

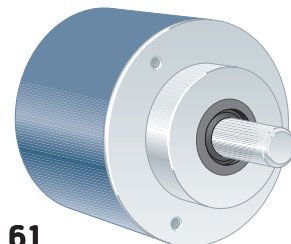

61

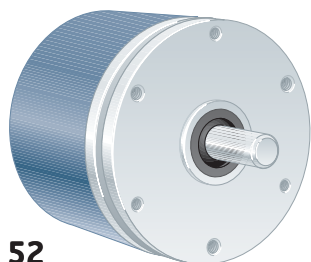

52

## Short description:

- >> 13 bit SSI output
- >> Binary or Gray coded
- >> 5 Vdc or 9...36 Vdc
- >> IP 67 at housing, IP 66 at shaft inlet
- >> Robust housing for harsh environment
- >> Shock and vibration protected

## Suitable applications:

- >> Standard to demanding industrial applications
- >> Positioning applications
- >> Printing machines
- >> Packaging machines

## General information

Encoder data	
Type	RSA 507
Operating temperature	-40°C .. +80°C
Storage temperature	-30°C .. +80°C
Ingress protection class	IP-67 according to IEC 60529
At shaft inlet	IP-66 according to IEC 60529
Vibration (55 to 2000Hz)	< 300 m/s <sup>2</sup> according to IEC 60068-2-6 <sup>(1)</sup>
Shock (6ms)	< 2000 m/s <sup>2</sup> according to IEC 60068-2-27
Cover material	Aluminium
Cover surface treatment	Coated and cromated or anodized
Weight	Approx. 300g
Accuracy and resolution	
Resolution	13 Bit, 8192 positions per revolution
Accuracy	± 1 LSB

## Flange option

Flange type	51, LL58	63, Synchro	61, Clamping	52, LL68
Outer diameter	ø58 mm	ø58 mm	ø58 mm	ø68 mm
Mounting holes	3 x M3 & 3 x M4	3 x M4	3 x M3	3 x M3 & 3 x M4
Flange material	Aluminium	Aluminium	Aluminium	Aluminium
Surface treatment	Anodized	Anodized	Anodized	Anodized

## Shaft option

Shaft type	Ø 6 round	Ø 6 with face	Ø 10 round	Ø 10 with face
Axial shaft load	50 N	50 N	50 N	50 N
Radial shaft load	60 N	60 N	60 N	60 N
Mech. permissible speed	6000 rpm (12 000)	6000 rpm (12 000)	6000 rpm (12 000)	6000 rpm (12 000)
Shaft material	Stainless steel	Stainless steel	Stainless steel	Stainless steel
Moment of inertia	1,9 x 10 <sup>-6</sup> kgm <sup>2</sup>	1,9 x 10 <sup>-6</sup> kgm <sup>2</sup>	2,0 x 10 <sup>-6</sup> kgm <sup>2</sup>	2,0 x 10 <sup>-6</sup> kgm <sup>2</sup>

<sup>(1)</sup><150m/s<sup>2</sup> on encoders with connectors



### Connection option

Connector type	Cable	8pM12	17 pin EML	8 pin PT
Function	Colour	PIN	PIN	PIN
Clock +	Yellow	3	8	A
Clock -	Green	4	9	B
Data +	White	5	14	C
Data -	Black	6	17	D
Code Sequence	Violet	8	2	H
Hold	Brown	NA	NA	G
0V	Blue	1	10	F
+EV	Red	2	7	E
Housing	Shield	Chassis	Chassis	Chassis
<b>Connecting direction (available on flange option -51, -63, -61)</b>				
Axial	Yes	Yes	Yes	Yes
Radial	Yes	Yes	Yes	Yes
<b>Connecting direction (available on flange option -52)</b>				
Axial	No	No	No	Yes
Radial	Yes	No	No	No

### Electrical option

Power supply	5Vdc ±10%	9-36Vdc
Polarity protected	No	Yes
<b>Output interface SSI</b>		
Short circuit protected	Yes	
Current consumption	100mA	50mA @ 24Vdc
Max current consumpt.	150mA	110mA
Output circuitry	RS-422	
Output frequency	100kHz...1MHz	
Cable length (max)	Frequency dependent	
Code type	Binary or Gray	
Position update freq.	16MHz	
Start up delay	25ms	
<b>Input 1 (Code sequence)</b>		
Code sequence	If not connected or connected to 0V the position will increase when the shaft is turned clockwise.	
U <sub>high</sub>	> 2V	> EV x 0.6
U <sub>low</sub>	< 0.7V	< EV x 0.25
Delay	75µs	
<b>Input 2 (Hold)</b>		
Hold	When connected to +EV or a logic high level will the position not be changed when the shaft is turned.	
U <sub>high</sub>	> 2V	> EV x 0.6
U <sub>low</sub>	< 0.7V	< EV x 0.25
Delay	75µs	

### Accessories

Accessories	Part number
Mating connector 8 pin M12	00201081 <sup>(1)</sup>
8 pin PT	00201009 <sup>(1)</sup>
17 pin EML	01209085 <sup>(1)</sup>
Coupling 6-6 mm	464192222 <sup>(2)</sup>
10-10 mm	464333232 <sup>(2)</sup>
Mounting bracket	00208011 <sup>(3)</sup>
Bearing box	01209010 <sup>(4)</sup>

- <sup>(1)</sup> Also available with assembled cable.
- <sup>(2)</sup> Other couplings are also available.
- <sup>(3)</sup> Only for 63 Synchro and 61 Clamping flanges.
- <sup>(4)</sup> Only for 63 Synchro flange.

For additional accessories like assembled cables, mounting clamps, measuring wheels, draw wire box etc. Please advise separate datasheets for accessories.



## Dimensions

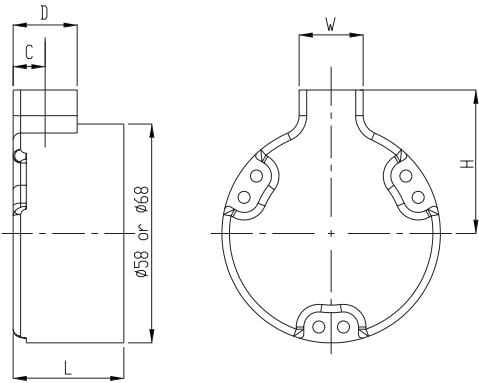

Connector	Orientation	L	H	W	D	C
Cable	Radial Ø58	29,4	34	17	17	8,5
	Radial Ø68	44,7	34	0	0	14
	Axial	38,9				
EML	Radial	29,4	32	27	27	13,5
	Axial	38,9				
8p M12	Radial	29,4	38	27	27	9,5
	Axial	38,9				
8p PT	Radial	29,4	41	27	27	13,5
	Axial Ø58	38,9				
	Axial Ø68	44,7				

Note: For complete encoder dimension please add connector and flange dimensions.

## Flanges

### 51, LL58

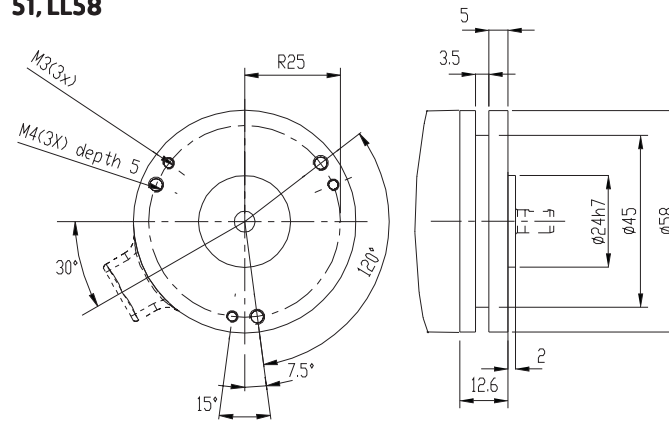

### 63, Synchro

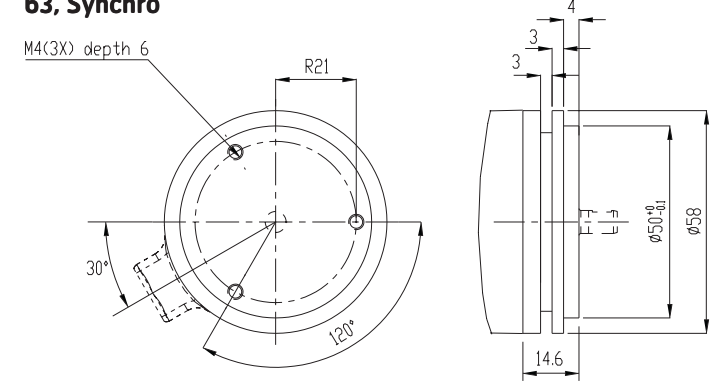

### 61, Clamping

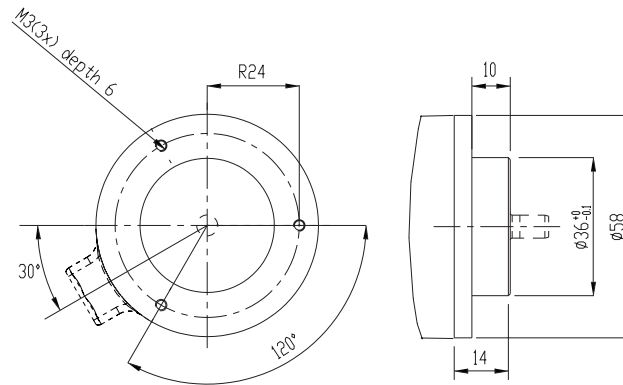

### 52, LL68

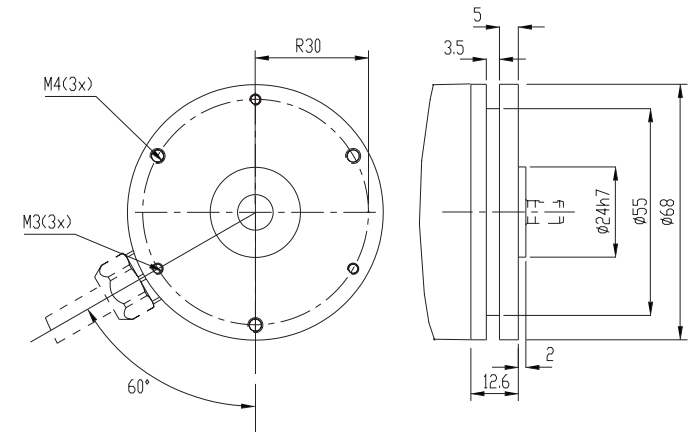



## Connectors

**Cable**  
16x0,25 shielded

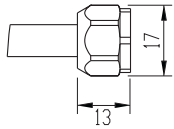

**8pin M12**

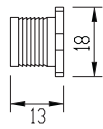

**17pin EML**

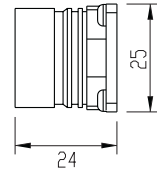

**8pin PT**

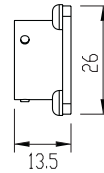

## Shafts

**6 mm with face**

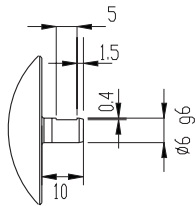

**6 mm round**

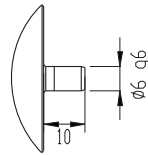

**10 mm with face**

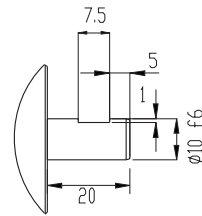

**10 mm round**

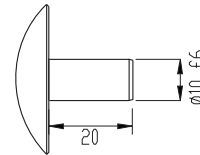

## Various combinations/examples

**RSA 507 51**

10 mm with face, axial M12

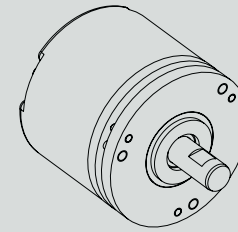

**RSA 507 63**

6 mm with face, radial PT

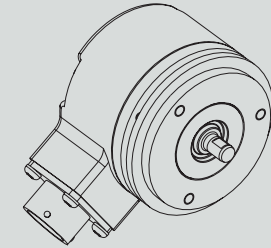

**RSA 507 61**

6 mm round, radial cable

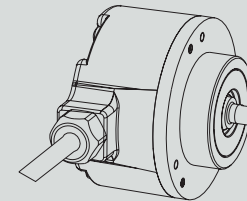

**RSA 507 52**

6 mm with face, axial M12

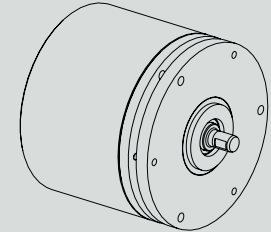

## Ordering information Tick your choice

Type	RSA 507			
Flange	51, LL58	63, Synchro	61, Clamping	52, LL68
Shaft	Ø6mm round	Ø6mm with face	Ø10mm round	Ø10mm with face
Electronics	Supply 5Vdc	9-36Vdc		
	Output SSG, Gray	SSB, Binary		
Connection	Cable <sup>(1)</sup>	8 pin M12	17 pin EML	8 pin PT
Connecting direction	Axial/Radial	Radial/Axial	Radial/Axial	Radial/Axial
Resolution	13 bit			

<sup>(1)</sup> Note: Please specify cable length when ordering

Ordering example: RSA 507 63 Ø10ro 9-36Vdc SSG Cable Radial 13bit  
Assembly drawing is available upon request from Leine & Linde AB



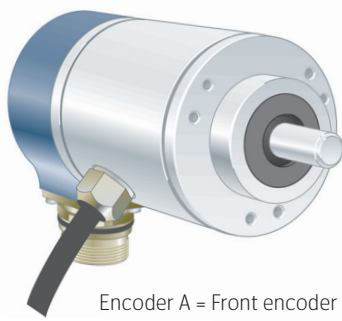

Encoder A = Front encoder  
Encoder B = Rear encoder

## Ruggedized dual shaft encoder

- 6 short-circuit protected outputs
- IP 67 at housing, IP 66 at shaft inlet
- 5 Vdc or 9 .. 30 Vdc
- Robust housing for harsh environment
- Shock and vibration protected
- Possible combinations; incremental – incremental or incremental – absolute

Encoder A is specified by this datasheet. Encoder B can be any 58 mm encoder, incremental or absolute, with 61 clamping flange and Ø10 mm shaft. Specify encoder B from RSI 500 series or RSA 500/600 series and observe that the selected encoder type may determine the overall technical specification of the RSD 525.



## General information

Encoder data	
Type	RSD 525
Operating temperature	-40 °C .. +70 °C
Storage temperature	-30 °C .. +70 °C
Ingress protection class	IP-67 according to IEC 60529, At shaft inlet: IP-66 according to IEC 60529
Vibration (55 to 2000 Hz)	<300 m/s <sup>2</sup> according to IEC 60068-2-6 (<150 m/s <sup>2</sup> on encoders with connectors)
Shock (6 ms)	<2000 m/s <sup>2</sup> according to IEC 60068-2-27
Cover material	Aluminium
Cover surface treatment	Coated and cromated or anodized
Weight	Approx. 600 g
Accuracy and resolution	
Line count	1 .. 5000 ppr <span style="float: right;">5001 .. 10 000 ppr</span>
Dividing error	±50 °el <span style="float: right;">±90 °el</span>
Channel separation	90 ±25 °el <span style="float: right;">90 ±45 °el</span>
Measuring steps	4 x line count
Requirements of Encoder B	
Shaft	Ø10 ro
Flange	61 Clamping flange

## Flange option

Flange type	51, LL58	63, Synchro	61, Clamping	52, LL68
Outer diameter	Ø58 mm	Ø58 mm	Ø58 mm	Ø68 mm
Mounting holes	3 x M3 & 3 x M4	3 x M4	3 x M3	3 x M3 & 3 x M4
Flange material	Aluminium	Aluminium	Aluminium	Aluminium
Surface treatment	Anodized	Anodized	Anodized	Anodized

## Shaft option

Shaft type	Ø6 round	Ø6 with face	Ø10 round	Ø10 with face
Axial shaft load	50 N	50 N	50 N	50 N
Radial shaft load	60 N	60 N	60 N	60 N
Mech. permissible speed	6000 rpm (12 000)	6000 rpm (12 000)	6000 rpm (12 000)	6000 rpm (12 000)
Shaft material	Stainless steel	Stainless steel	Stainless steel	Stainless steel
Moment of inertia	4,6 x 10 <sup>-6</sup> kgm <sup>2</sup>	4,6 x 10 <sup>-6</sup> kgm <sup>2</sup>	4,6 x 10 <sup>-6</sup> kgm <sup>2</sup>	4,6 x 10 <sup>-6</sup> kgm <sup>2</sup>



## Connection option

Connection type	Cable	8 pin M12
Function	Colour	Pin
S00	Yellow	4
S00 inverted	Black	5
S90	Green	3
S90 inverted	White	1
Sref	Brown	2
Sref inverted	Violet	6
+E Volt	Red	8
0 Volt	Blue	7
STATUS	Grey	NA
Housing	Shield	Chassis
Connecting direction		
Radial	Yes	Yes

NA = Not Available

## Electrical option

Power supply	5 V $\pm$ 10%	9 .. 30 V	
Polarity protected	No	Yes	
Output signals	TTL <sup>(1)</sup>	HTL	RS-422
Short circuit protected	Yes	Yes	Yes
Current consumption	45 mA	50 mA @ 24 V	25 mA @ 24 V
Max consumption	75 mA	75 mA	40 mA
Output load (max)	$\pm$ 20 mA	$\pm$ 40 mA	$\pm$ 20 mA
Output frequency (max)	300 kHz	300 kHz	300 kHz
U <sub>high</sub> at 10 mA load	> 3.0 V	> +E V - 2.0 V	> 3.0 V
U <sub>low</sub> at 10 mA load	< 0.4 V	< 1.15 V	< 0.4 V
Cable length (max)	50 m	200 m @ 50 kHz	1 km (TIA/EIA-422-B)
STATUS output	Yes High level: Encoder OK, Low level: Warning/Failure	Yes High level: Encoder OK, Low level: Warning/Failure	Yes High level: Encoder OK, Low level: Warning/Failure

<sup>(1)</sup> TTL output comply to the RS-422 standard when differential transmission is used.

## Output circuit

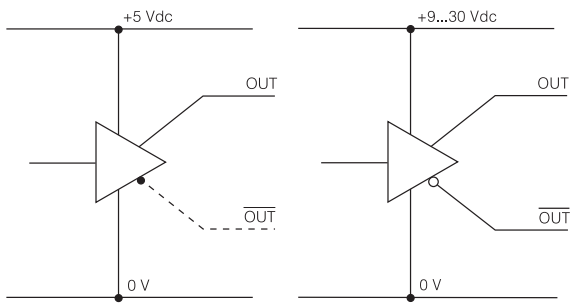

## Output signals

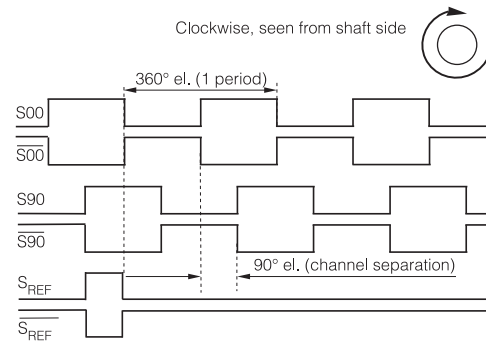

## Status outputs

TTL-output / RS-422

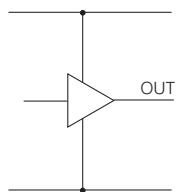

HTL-output

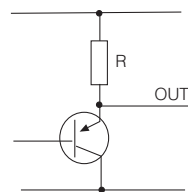

## Dimensions

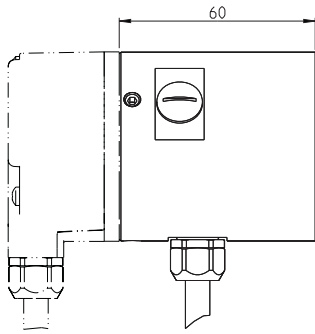

Total length of the RSD 525 encoder is determined by encoder B. Please advice appropriate datasheet for additional dimensions of encoder B.

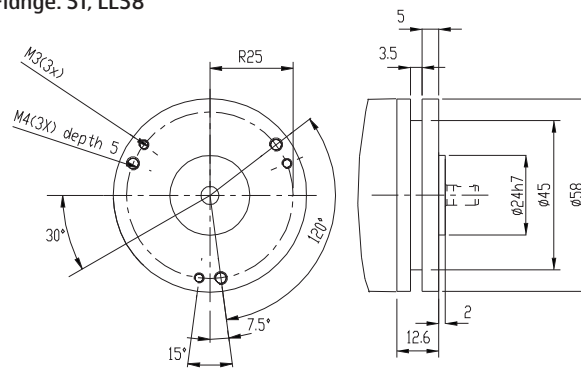
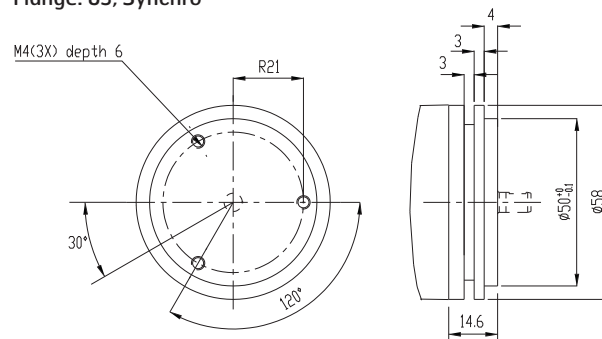
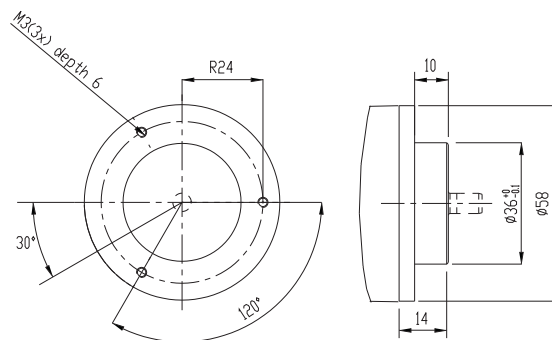
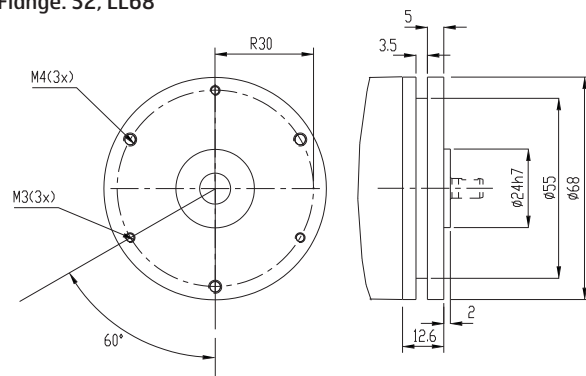
**Flange: 51, LL58****Flange: 63, Synchro****Flange: 61, Clamping****Flange: 52, LL68**

## Dimensions

Connector: Cable, 5x2x0,25 shielded

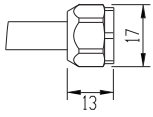

Connector: 8 pin M12

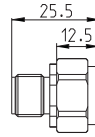

Shaft: 6 mm with face

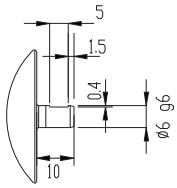

Shaft: 6 mm round

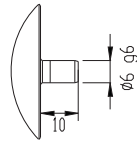

Shaft: 10 mm with face

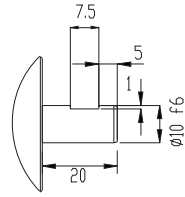

Shaft: 10 mm round

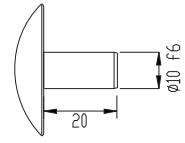

## Various combinations / examples

RDS 525 63, 6 mm, radial cable with 25 bit PROFIBUS

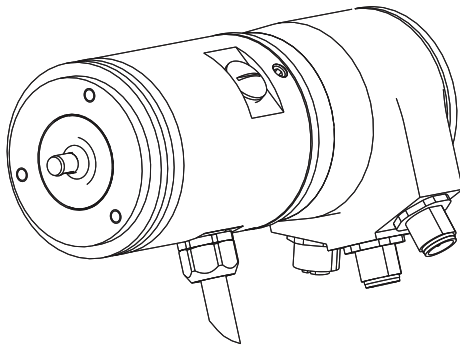

RSD 525 52, 10 mm, radial cable with incremental encoder

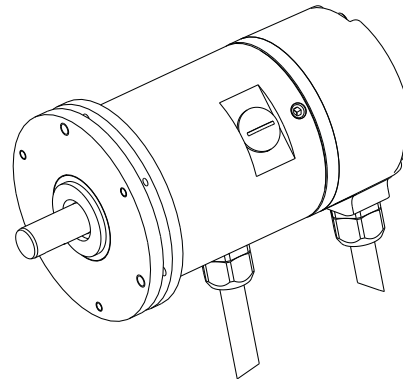

## Ordering information

Type	RSD 525			
Flange	51, LL58	63, Synchro	61, Clamping	52, LL68
Shaft	Ø6 round	Ø6 with face	Ø10 round	Ø10 with face
Electronics <sup>(1)</sup>	Supply: 5 Vdc	Supply: 9 .. 30 Vdc	Supply: 9 .. 30 Vdc	
	Output: TTL	Output: HTL	Output: RS-422	
Connection	Cable	8 pin M12		
Connecting direction	Radial		Radial	
Line count	1 .. 5000	5001 .. 10 000		
Encoder B	Provide part number or product designation when ordering			

<sup>(1)</sup> Possible combinations: 5Vdc/TTL, 9..30Vdc/HTL or 9..30Vdc/RS-422

### Please, specify line count and cable length when ordering.

Ordering example:

Encoder A: RSD 525 63 Ø6wf 5Vdc 1024ppr TTL 8pinM12 Radial

Encoder B: By specifying the required encoder unique part number or designation as:  
456123-01 or RSI 503 61 Ø10ro 9..30Vdc 512ppr HTL Cable Radial

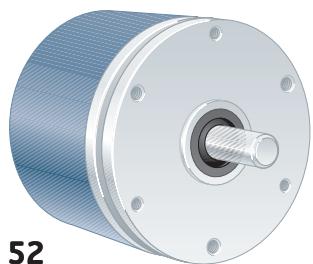

52

CLS replaces 521

PPS replaces 522

## Short description:

- >> Electrical interfaces:  
Current Limited Source  
PTC Protected Source
- >> IP 67 at housing,  
IP 66 at shaft inlet
- >> 9...30 Vdc
- >> Robust housing for harsh  
environment
- >> Shock and vibration  
protected

## Suitable applications:

- >> Standard to demanding  
industrial applications

## General information

Encoder data		
Type	RSI 593	
Operating temperature	-40°C .. +70°C	
Storage temperature	-30°C .. +70°C	
Ingress protection class	IP-67 according to IEC 60529	
At shaft inlet	IP-66 according to IEC 60529	
Vibration (55 to 2000Hz)	< 300 m/s <sup>2</sup> according to IEC 60068-2-6 <sup>(1)</sup>	
Shock (6ms)	< 2000 m/s <sup>2</sup> according to IEC 60068-2-27	
Cover material	Aluminium	
Cover surface treatment	Coated and cromated or anodized	
Weight	Approx. 300g	
Accuracy and resolution		
Line count	1..5000 ppr	5001..10 000 ppr
Dividing error	± 50 °el	± 90 °el
Channel separation	90 ± 25 °el	90 ± 45 °el
Measuring steps	4 x Line count	

## Flange option

Flange type	52, LL68
Outer diameter	ø68 mm
Mounting holes	3 x M3 & 3 x M4
Flange material	Aluminium
Surface treatment	Anodized

## Shaft option

Shaft type	Ø6 round	Ø6 with face	Ø10 round	Ø10 with face
Axial shaft load	50 N	50 N	50 N	50 N
Radial shaft load	60 N	60 N	60 N	60 N
Mech. permissible speed	6000 rpm (12 000)	6000 rpm (12 000)	6000 rpm (12 000)	6000 rpm (12 000)
Shaft material	Stainless steel	Stainless steel	Stainless steel	Stainless steel
Moment of inertia	1,9 x 10 <sup>-6</sup> kgm <sup>2</sup>	1,9 x 10 <sup>-6</sup> kgm <sup>2</sup>	2,0 x 10 <sup>-6</sup> kgm <sup>2</sup>	2,0 x 10 <sup>-6</sup> kgm <sup>2</sup>

<sup>(1)</sup><150m/s<sup>2</sup> on encoders with connectors



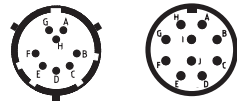

### Connection option

Connector type	Cable	8 pin PT	10 pin MS
Function	Colour	PIN	PIN
S00	Yellow	D	D
S00 inverted <sup>1</sup>	Black	C	C
S90	Green	A	A
S90 inverted <sup>1</sup>	White	B	B
Sref	Brown	G	G
Sref inverted <sup>1</sup>	Violet	H	H
+E Volt	Red	E	E
0 Volt	Blue	F	F
STATUS	Grey	NA	I
Case	Shield	Chassis	Chassis
Connecting direction (available on flange option -52)			
Axial	No	Yes	Yes
Radial	Yes	No	No

<sup>1</sup> On encoders with PPS electronics the inverted signals are not available. NA=Not Available

### Electrical option

Power supply	9-30 Vdc	
Polarity protected	Yes	
Output signals	Current Limited Source*	PTC Protected Source**
Short circuit protected	Yes, in source	Yes, in source
Current consumption	60 mA at 24Vdc	60 mA at 24Vdc
Max consumption	90 mA	90 mA
Output load (max)	+19 mA / - 40 mA	±40 mA
Output frequency (max)	200 kHz	200 kHz
U <sub>high</sub> at 10mA load	---	> +EV - 4.0 V
U <sub>low</sub> at 10mA load	< 6 V	< 1.3 V
Cable length (max)	---	200 m @ 100 kHz
STATUS output	Yes	Yes
<i>High level</i>	Encoder OK	Encoder OK
<i>Low level</i>	Warning/Failure	Warning/Failure

\* CLS = Current Limited Source (replaces model 521)

\*\* PPS = PTC Protected Source (replaces model 522)

### Output circuit

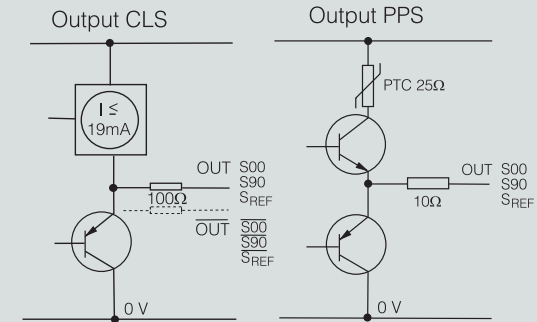

### Output signals, CLS

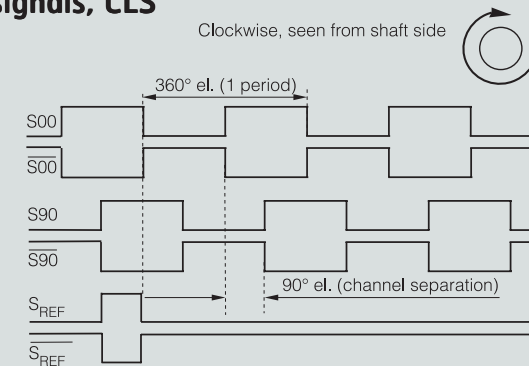

### Output signals, PPS

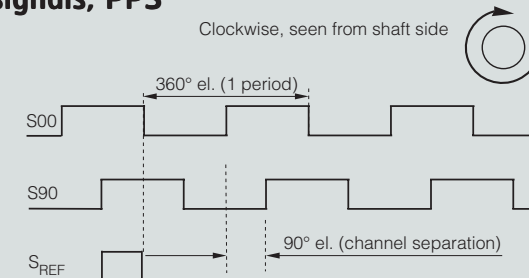



## Dimensions

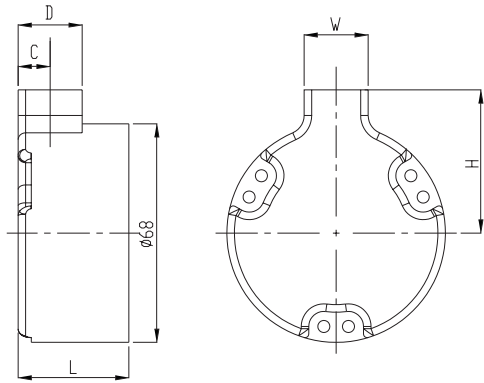

Connector	Orientation	L	H	W	D	C
Cable	Radial $\varnothing 68$	44.7	34	0	0	14
PT 8p	Axial $\varnothing 68$	44.7	-	-	-	-
MS 10p	Axial $\varnothing 68$	44.7	-	-	-	-

## Flanges

### 52, LL68

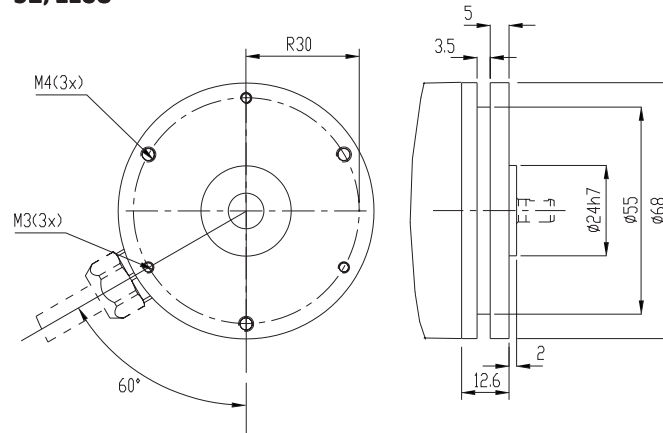



## Connectors

**Cable**  
5x2x0,25 shielded

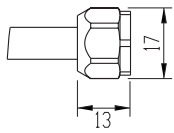

**8pin PT**

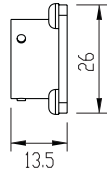

**10pin MS**

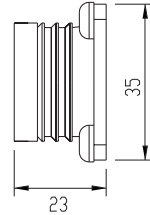

## Shafts

**6 mm with face**

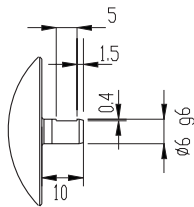

**6 mm round**

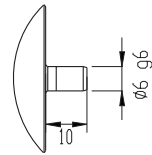

**10 mm with face**

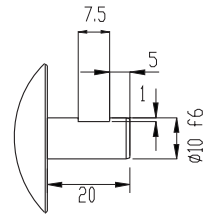

**10 mm round**

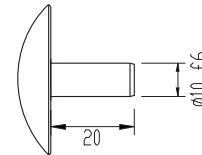

## Various combinations/example

**RSI 593 52**  
6 mm with face, radial cable

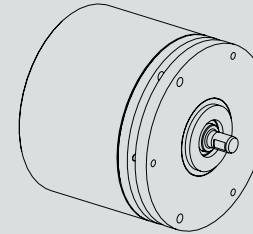

## Ordering information Tick your choice

Type	RSI 593			
Flange	52, LL68			
Shaft	Ø6 round	Ø6 with face	Ø10 round	Ø10 with face
Electronics	Supply	9-30Vdc		
	Output	CLS PPS		
Connection	Cable	8 pin PT	10 pin MS	
Connecting direction	Radial	Axial	Axial	
Line count	1..5000	5001..10 000		

**Please, specify line count and cable length when ordering**

Ordering example: RSI 593 52 Ø6ro 9-30Vdc 1024ppr CLS 8 pin PT Axial