

BELKI Oil Separator 211 H - 200 LS



Area of use

The BELKI Oil Separator is applied for removal of tramp oil and other surface contaminants from process fluids, e.g. coolants and degreasers. The BELKI Oil Separator is utilised as a fixed installation or mounted on a trolley for maintenance of any number of tanks.

Operation

The surface is skimmed by a self-regulating suction unit. The slow revolving, electrically driven diaphragm pump is designed to keep the tramp oil from being mixed into the fluid, thereby ensuring an effective separation. The tramp oil flows to a collecting container and the cleaned fluid flows back to the machine tank.

Advantages

- Self-regulating suction unit, only skimming the surface
- The suction unit compensates for level variations in the tank
- Gentle operation of the pump, ensuring effective oil separation
- Easily adjustable so that only the oil is flowing to the oil container
- The oil container has decantation function
- Possibility for connection of several suction units (dependent on model type)
211 H max 1 pcs. / 321 and 60 S max 2 pcs. / 200 LS max 4 pcs.
- Module constructed; oil separator and pump can be mounted separately (for 60 S and 200 LS)



Filtration with capacity

Technical Specifications

211 H

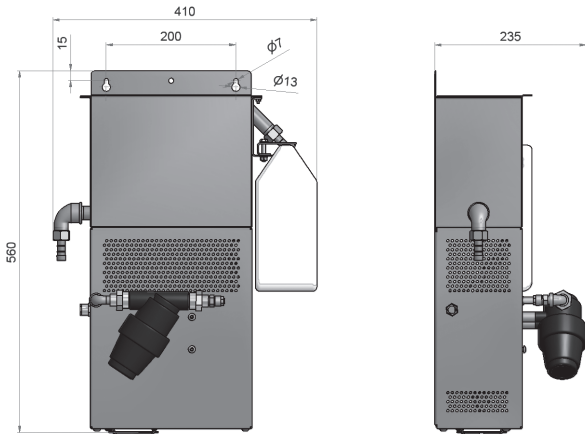

321

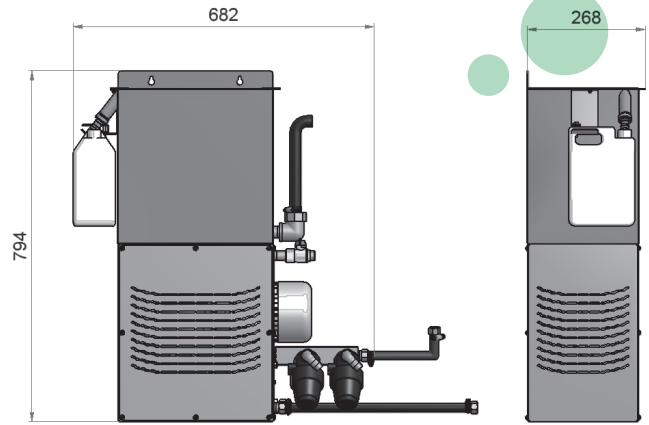

60 S

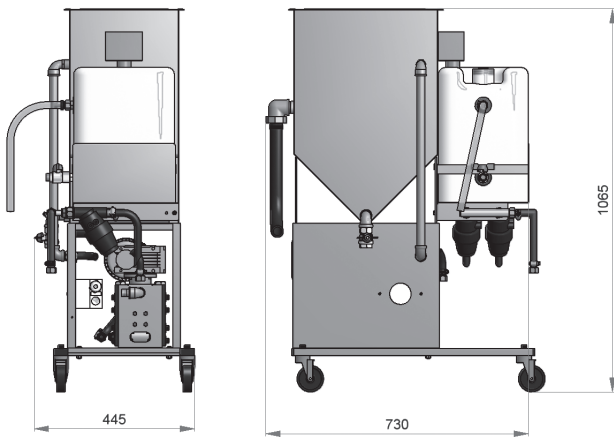

200 LS

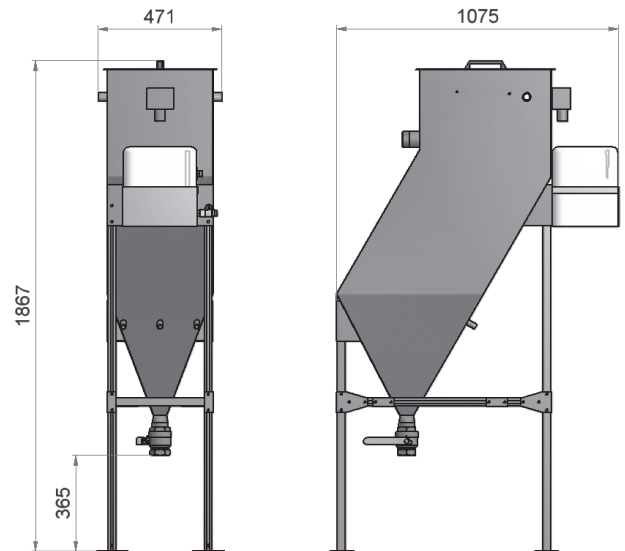

Type:		211 H	321	60 S	200 LS
Capacity	l / h	25	150	300	600
Surface	m ²	1-2	5	15	25
Oil container	l	2,5	5	20	25
Connection	V / Hz	230/ 50-60 Hz	230/400 50 Hz 265/460 60 Hz	230/400 50 Hz 265/460 60 Hz	3 x 400 50Hz
Consumption	W	25	250/290	250/290	250
Material		Stainless steel	Stainless steel	Stainless steel	Stainless steel
Weight	kg	12,5	36	57	100
Length	mm	410	682	730	1075
Width	mm	235	268	445	471
Height	mm	560	794	1065	1867

Presented by / Überreicht durch:



Filtration with capacity