

**MANUALE TECNICO
TECHNICAL MANUAL**

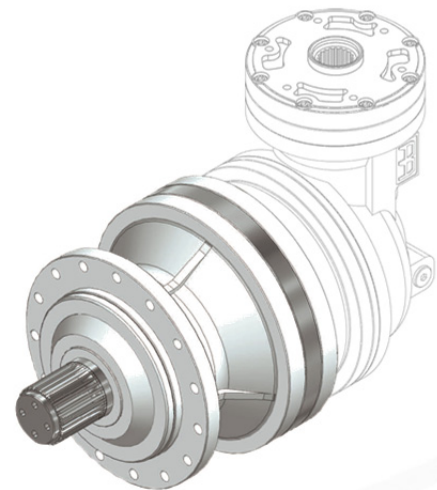
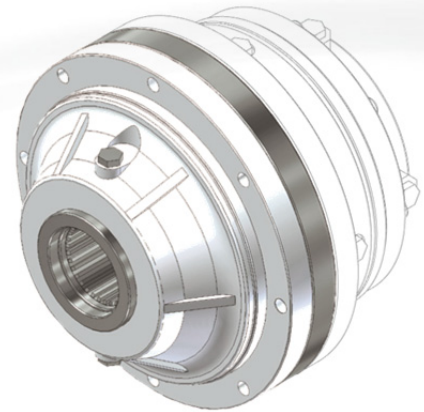

CONTENTS

1	INTRODUCTION	32
1.1	<i>Purpose of the document</i>	32
1.2	<i>General warnings</i>	32
1.3	<i>Guarantee conditions</i>	32
1.4	<i>Keeping the instructions</i>	32
1.5	<i>Copyright</i>	32
1.6	<i>Revisions</i>	32
2	DEFINITIONS AND SYMBOLS	33
3	PRODUCT IDENTIFICATION	34
3.1	<i>Product marking and type designation</i>	34
3.2	<i>Plate legibility</i>	35
3.3	<i>CE Declaration of Conformity to the Technical Regulation Directives</i>	35
4	PRODUCT SPECIFICATIONS	36
4.1	<i>General functions and range of applications, intended use</i>	36
4.2	<i>Not intended use</i>	36
4.3	<i>Dimensions and mass</i>	36
4.4	<i>Supply conditions</i>	36
4.5	<i>Negative brake powering data</i>	36
4.6	<i>Thermal power</i>	37
4.7	<i>Environmental conditions and use/operating limits</i>	37
4.8	<i>Information about accident prevention</i>	37
5	PACKING, HANDLING AND STORING	38
5.1	<i>Handling</i>	38
5.2	<i>Storing</i>	38
5.3	<i>Unpacking</i>	38
5.4	<i>Disposing of the packaging materials safely</i>	38
6	INSTALLATION	38
6.1	<i>Preliminary checks</i>	38
6.2	<i>Installation and assembly</i>	39
6.3	<i>Using the brakes</i>	42
6.4	<i>Friction shrink discs</i>	43
6.5	<i>Torque arms</i>	44
7	LUBRICATION	45
7.1	<i>Viscosity</i>	45
7.2	<i>Additives</i>	45
7.3	<i>Contamination</i>	45
7.4	<i>Assembly position and where the plugs are located</i>	48
7.5	<i>Filling up</i>	50
7.6	<i>Auxiliary cooling systems</i>	55
8	COMMISSIONING	56
8.1	<i>Inspection</i>	56
8.2	<i>Control of the surface temperature</i>	56
9	MAINTENANCE	57
9.1	<i>Cleaning</i>	57
9.2	<i>Routine maintenance</i>	57
9.3	<i>Extraordinary maintenance</i>	58
9.4	<i>Repacking</i>	58
10	DECOMMISSIONING THE PRODUCT	58
11	TROUBLESHOOTING	59
12	TYPE INSPECTION CERTIFICATE	60

1 INTRODUCTION

1.1 Purpose of the document

This technical manual gives all the indications necessary for transporting, storing, handling, installing, using and servicing planetary reduction gears of the 2000 Series guaranteeing product integrity and compliance with current safety rules and regulations.

1.2 General warnings

Failure to abide by the indications given in this manual could be a hazard source for the safety of people and the environment besides impairing operation of the reduction gear.

Reggiana Riduttori s.r.l. declines all liabilities in the case of:

- using the reduction gear in a way that does not comply with what was established at the designing stage and not explicitly specified herein;
- incorrect installation of the reduction gear or in a way that does not conform to what is specified herein;
- alterations made or parts changed that were not expressly authorised;
- work done on the gear by unauthorised people.

1.3 Guarantee conditions

Reggiana Riduttori s.r.l. guarantees its products for 24 months from the date of shipment. Charges and costs connected to assessing a fault and replacing pieces shall be borne by the Customer.

Unauthorised work or work carried out by unauthorised people will invalidate the guarantee.

1.4 Keeping the instructions

This manual must be kept near where the reduction gear is installed and made available to the operating and maintenance personnel.

1.5 Copyright

Total or even partial reproduction of this manual is forbidden unless written authorisation is given by **Reggiana Riduttori s.r.l.**

1.6 Revisions

Reggiana Riduttori s.r.l. reserves the right to revise this manual, altering or integrating it without notice.

2 DEFINITIONS AND SYMBOLS

Some of the definitions and symbols used often in this manual are:

Operator:

person trained to install, work, adjust, clean, and carry out routine maintenance on the reduction gear.

Expert maintenance engineer:

person chosen and trained out of all those who have mechanical and electrical expertise with knowledge of the safety rules, to repair and carry out extraordinary maintenance on the reduction gear.

Routine maintenance:

programmed operations that have the purpose of guaranteeing the proper working order of the reduction gear.

Extraordinary maintenance:

these operations are not programmed and require the skill of an expert maintenance engineer.

ATTENTION

This indicates situations of serious danger that could put the health and safety of people at risk. Take all the necessary precautions established by the accident prevention laws.

IMPORTANT

This indicates technical information of a particularly important nature and which, if disregarded, could cause damage to the reduction gear and be a hazard source for the health and safety of people.

ATEX

All the regulations contained inside these boxes refer solely to products conforming to the ATEX 94/9/CE directive.

The operations connected to these regulations must always be carried out by specialized technicians with expertise on safety in environments where there is a potentially explosive atmosphere.

3 PRODUCT IDENTIFICATION

The 2000 series planetary reduction gears are identified by codes created in the following way:

RR	510	T	FS	65.60	RF
					Input configuration (optional) - Standard Input RF Setup RF BOC Setup BOC
					Reduction ratio $i = 3 \div 3000$
					Type of output MS/BS Male splined MC/BC Male cylindrical MH/BH Male hollow ME/BE Male hexagonal SS Splined reinforced SC Cylindrical reinforced SE Hexagonal reinforced SI Reinforced with integral pinion UC Male cylindrical, with feet FS Female splined VI Integral pinion (double centring) ZI Integral pinion (with flange)
					Number of stages - Single stage D Double stage T Triple stage Q Quadruple stage
					Size 65, 105, 110, 210, 310, 510, 710, 810, 1010, 1700
Type					
RR	Linear Reduction gear				
RA	Angular Reduction gear				

If it is possible to mount more than one bevel gear size in input, the different alternatives for the combinations are indicated with (A), (B), starting from the alternative with the smallest bevel gear.

Example: RA1700 (A), RA1700 (B).

3.1 Product marking and type designation

All **Reggiana Riduttori** products have an id plate positioned so as to be easily readable also after installation.

The following figure shows an example of a plate.

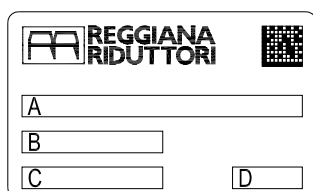

Legend	
A	Reduction gear type and ratio
B	ID code for ordering
C	Progressive serial number
D	Month/year of production



The reduction gears conforming to the 94/9/CE directive have an additional "ATEX" plate that gives the indications as specified by the UNI EN 13463-1 standard. An example is shown in the figure.



3.2 Plate legibility

It is the user's responsibility to make sure the plate is in excellent condition and that all the data on it can be read easily, and it must be cleaned regularly. If it is damaged or lost, the user must ask for a duplicate.



In the case of additional painting, protect the plate, checking its legibility after.

3.3 CE Declaration of Conformity to the Technical Regulation Directives

All **Reggiana Riduttori** products are designed in compliance with the Essential Safety Requirements laid down in the Machine Directive 98/37/CE.



Reduction gears that are going to be used in a potentially explosive atmosphere are designed and made in compliance with the "Essential Requirements for Safety and Health" of the ATEX 94/9/CE, Enclosure II, according to the following identification:

- Group: II
- Category: Gas 2G/Dust 2D
- Zones: Gas 1/Dust 21
- T4 temperature class for 2G
- Maximum surface temperature: 130°C for 2D

4 PRODUCT SPECIFICATIONS

4.1 General functions and range of applications, intended use

The **Reggiana Riduttori** planetary reduction gears are designed for transmitting power inside operating machines. They can be connected directly or indirectly to either an electric or hydraulic motor.

The planetary reduction gears are used for many different types of application, both industrial and mobile some of which are: the mechanical industry, the chemical and plastics industry, the food industry, building and constructions, mining industry, agriculture and forestry, transporting and lifting, marine sector, wind generators of energy.



The reduction gear must be used only for what it has been designed. If it is put to other uses it could be hazardous for the health and safety of people.

The reduction gears' intended uses are industrial and mobile, for which they have been specifically designed and made.

4.2 Not intended use

It is forbidden to use the reduction gear in a way that does not conform to what was established at the designing stage.

More specifically it is forbidden:

- for unqualified personnel to use the reduction gear;
- to install it in a way that fails to conform to the assembly position agreed when the order was placed;
- to dip the reduction gear in water or other liquids unless expressly agreed otherwise at the designing stage;
- to alter or replace parts of the reduction gear unless expressly authorised by **Reggiana Riduttori**;
- to do any welding on the surface of the reduction gear;
- to use the reduction gear in a potentially explosive atmosphere unless explicitly intended for such a purpose.

4.3 Dimensions and mass

To know the dimensions and mass of the reduction gears and accessories, refer to the most recent version of the **Reggiana Riduttori** Planetary Reduction Gears general catalogue.

4.4 Supply conditions

Unless agreed otherwise with the Customer, the **Reggiana Riduttori** products are supplied without lubricant, as indicated on a sticker on the outside of the reduction gear. The user must fill the reduction gear before using it.

The outside parts, except for the coupling surfaces and any specific requirements, are painted in a red, rustproof synthetic paint that can be painted over; if the Customer wants a top coat it is up to him.



If there is going to be a top coat of paint, follow these instructions:

- protect the O rings, ID plate (and the ATEX plate if there is one) and the level and bleeding plugs
- do not paint by dipping

The outside parts used for coupling (shafts, centrings, supporting surfaces, etc.) are protected with a film of rustproof oil. The parts inside the casings and kinematics are protected with rustproof oil.



The reduction gears conforming to the 94/9/CE directive are supplied with the following specifications:

- Viton ® seals are used
- a supplementary "ATEX" plate

4.5 Negative brake powering data

If the reduction gear is supplied together with an RF/RFF type negative brake, make sure the brake's opening circuit supply pressure is higher than the minimum opening pressure. For the pressures to work with, depending on the type of brake, please see "Using the brakes" further on.

4.6 Thermal power

Thermal power is the power that, applied at input to the continuously working reduction gear, stabilises the temperature of the oil inside the reduction gear at 90°C under the following test conditions:

- oil splash lubrication;
- reduction gear in a horizontal position not subject to air recirculation;
- input speed: 1000 rpm;
- quantity of oil corresponding to the half full mark;
- ISO VG 150 mineral oil;
- ambient temperature 20°C.

4.7 Environmental conditions and use/operating limits

The operating temperature recommended for **Reggiana Riduttori** products ranges between -20°C and +40°C.

Different conditions of use are however possible, taking certain designing measures which have to be agreed specifically with the **Reggiana Riduttori** technical service.

Operation is forbidden above the maximum ambient temperature of 40°C unless you are working at powers below the permitted thermal power and after conducting suitable operating tests.



Mounting the reduction gear inside a small compartment reduces thermal power dispersion capacity considerably.

If the power applied in input to the reduction gear exceeds the permitted thermal power specified in the catalogue or if the reduction gear is working inside a small compartment or with only a small change of air, we suggest an oil recirculation type cooling circuit as indicated in the catalogue.



The maximum surface temperature refers to measurements taken under normal use and installation conditions. If the reduction gear's conditions of use differ from these, the surface temperature could reach even higher values. In such an event, it is necessary to use an oil recirculation cooling circuit.

4.8 Information about accident prevention

Before doing anything on the reduction gear read carefully all the instructions given in this manual.

The person who sees to operating and servicing the reduction gear must:

- be adequately skilled technically and experienced in the specific sector;
- be informed about the conditions of danger and the resulting risks of injury;
- know and use the IPG established by current legislation (Italian Law Decree 626/94);
- act always paying maximum attention and in compliance with the safety rules and regulations laid down by international directives and by the laws in the country where the reduction gear is used.



In the case of reduction gears used in a potentially explosive atmosphere, the person who sees to operating and servicing them must, before doing anything, make certain the reduction gear is off and not working and prevent the machine from being started again accidentally.

It is also vitally important to ensure there is no potentially explosive atmosphere while servicing the reduction gear.

5 PACKING, HANDLING AND STORING

Reggiana Riduttori products are packed and shipped in crates or on pallets. Packaging is made to withstand the conditions of normal industrial environments. However, suitable protection measures must be taken if environmental conditions are particularly bad. The reduction gears are wrapped in plastic bags and, if they are being packed in crates, polystyrene or other similar material is put inside to soften knocks. This installation, operating and maintenance manual is packed with the reduction gear.

5.1 Handling

Handle the packs with equipment and lifting means that are suitable for this type of packaging.

Take into account the mass, dimensions, points for lifting and the barycentre (which, if necessary, you will find on the outside of the pack).



Handling must be entrusted to expert personnel who must work in compliance with the accident prevention rules and regulations so as to guarantee their own safety and that of others in the vicinity.

Follow these instructions for handling:

- find an area where the surface is flat and possibly big enough for unloading and depositing the packs;
- do not tilt or turn the packs upside down when lifting and moving;
- proceed with caution when positioning the packs, avoiding sudden movements and violent knocks.

Use suitable tools to take the reduction gears out of their packaging (chains, straps, ropes, eyebolts, hooks, etc.) and make sure the load is always balanced.

5.2 Storing

Do not store the planetary reduction gears in the open or where they would be subject to excessive dampness; never leave the reduction gears in direct contact with the ground.

If storing for more than 2 months, proceed as follows:

- fill the reduction gear with lubricant oil of the type foreseen and position the reduction gear so the bleeding plug is on top;
- protect the outside coupling surfaces with grease or a rustproof product;
- store in a dry, clean place where the temperature is between -15°C and +50°C with relative humidity not exceeding 80%.
All other conditions require specific packaging.



If you are going to use the reduction gear after being stored a long time:

- Clean the outside coupling surfaces and remove the rustproof product with ordinary solvents that can be found on the market; be careful never to let the solvent touch the seals.
This must be done away from all explosion hazard areas.
- If the reduction gear was filled with an oil different to what is needed for working, clean the inside before filling up.

5.3 Unpacking

When the goods are received they must be checked to see that they correspond to what is specified on the plate and in the order; also check that the contents of the pack have not been damaged during transport.

5.4 Disposing of the packaging materials safely

The packaging materials must be disposed of in accordance with the current environmental protection laws.

6 INSTALLATION



Installation is to be entrusted to expert personnel working in compliance with the accident prevention rules and regulations so as to guarantee their own safety and that of others in the vicinity.

6.1 Preliminary checks

The following checks are necessary before installing the reduction gear:

- remove all packaging materials and clean the reduction gear, paying particular attention to the centring and coupling surfaces which must be free of paint;

- make sure the bleeding, level and oil drain plugs are in their right positions based on the mounting position of the reduction gear. If the reduction gear is supplied with a negative brake check that the bleeding, level and oil drain plugs of the brake are in right position;
- check that the structure to which the reduction gear is going to be connected is sufficiently rigid and robust to withstand the weight of the reduction gear and the forces generated during operation;
- make sure the surfaces for coupling to the reduction gear are flat and clean;
- ensure that the machine to which the reduction gear is going to be connected is off and accidental switching on is impossible;
- grease the centring and coupling surfaces and put the reduction gear in proximity of the installation area;

6.2 Installation and assembly

Mount the reduction gear, fixing it to the structure in the right points. It is very important to prevent the reduction gears' supporting flanges from being tensioned during assembly: to do this make sure the counter-flange for fastening adheres perfectly to the reduction gear flange.

Check both in the male and female versions that the alignment between the reduction gear shaft and the splined countershaft is correct (sleeve, joint, splined shaft, etc.) to avoid deterioration of the splined profiles.

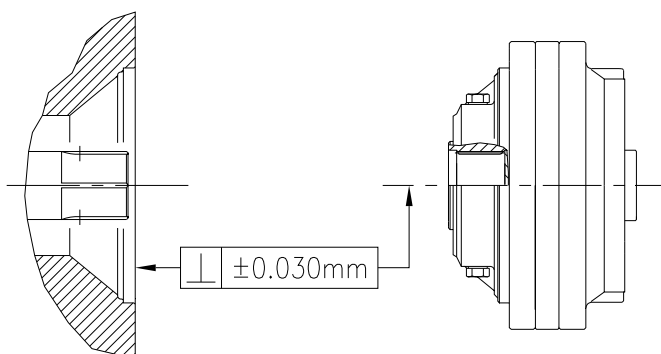

Tighten the securing screws based on the dimensions and class according to the values given in the following table.

Screw diameter	Max. preload [N]			Max. Torque [Nm]		
	8.8	10.9	12.9	8.8	10.9	12.9
	8G	10K	12K	8G	10K	12K
M4	3940	5540	6650	3.1	4.3	5.2
M5	6350	8950	10700	6	8.4	10.1
M6	9020	12700	15200	10.3	14.6	17.5
M7	13000	18200	21800	16.9	23.6	28.3
M8	16400	23100	27700	24.8	34.9	41.9
M9	21600	30500	36300	36.7	51.8	61.7
M10	26000	36600	43800	49.7	70	83.7
M12	37800	53200	63800	84.6	119	143
M14	51600	72500	87000	134.6	189.2	227
M16	70200	99000	119000	204	288	346
M18	86000	121000	145000	284	400	480
M20	110000	155400	185000	396	556	666
M22	136000	191000	229000	530	745	900
M24	159000	223000	267000	700	980	1170
M27	206000	289000	347000	1010	1420	1700
M30	280000	399000	467000	1500	2130	2500

Use either class 10.9 or 12.9 screws if the application entails significant knocks, frequent stops, starts and/or reversal of direction or when 70% of the maximum permitted torque is exceeded.

When mounting the female reduction gears, place the splined coupling shaft with the reduction gear with tolerance (e9). In addition, provide holes for housing the pins; the recommended supporting surface overhangs are shown in the following figures.

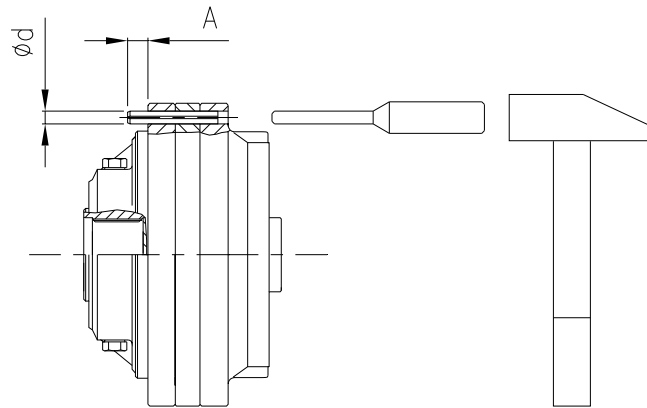

		$\varnothing d$	A
RR310	FS	10	14
RR310D	FS		
RR310T	FS		
RR310Q	FS		
RR510	FS	10	14
RR510D	FS		
RR510T	FS		
RR510Q	FS		
RR710	FS	10	14
RR710D	FS		
RR710T	FS		
RR710Q	FS		

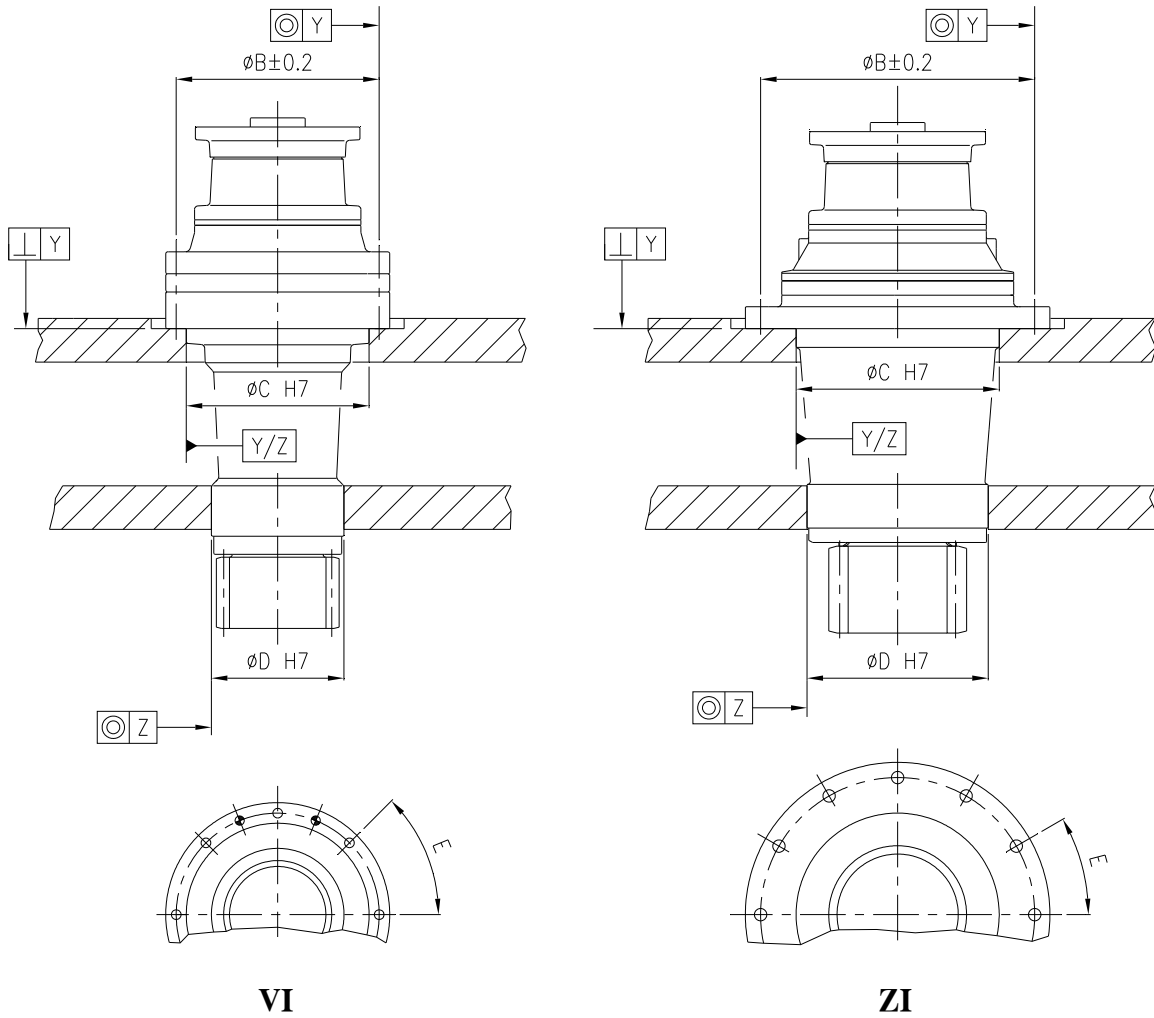

		$\varnothing d$	A
RR810	FS	12	14
RR810D	FS		
RR810T	FS		
RR810Q	FS		
RR1010	FS	12	13
RR1010D	FS		
RR1010T	FS		
RR1010Q	FS		
RR1700	FS	12	13
RR1700D	FS		
RR1700T	FS		
RR1700Q	FS		

The recommended dimensions are given below for assembling the reduction gears for VI and ZI rotation with respect to the machine.



VI

ZI

	B	C	D	E			
RR510 VI RR710 VI	222	200	145	45°±10'	0.3	0.05	0.05
RR810 VI	275	250	200	45°±10'	0.3	0.05	0.05
RR1010 VI	299	280	250	45°±10'	0.3	0.05	0.1
RR1700 VI	314	280	250	30°±8'	0.3	0.05	0.1
RR810 ZI	325	250	200	36°±10'	0.3	0.05	0.1
RR1010 ZI RR1700 ZI	380	280	250	30°±8'	0.3	0.05	0.1

6.3 Using the brakes

For reduction gears to be used with a hydraulic motor and equipped with a negative brake, when installing connect a pressurized pipe of the hydraulic circuit either to the control hole on the brake or to the motor control valve (if pre-arranged).



For the brakes' command use a hydraulic type of mineral oil. The minimum opening pressures for the negative brakes are given in the following table.

		RF2					
		RF2/7	RF2/14	RF2/21	RF2/32	RF2/43	RF2/60
Static torque	[Nm]	60÷80	130÷150	200÷220	310÷340	410÷450	570÷600
Minimal opening pressure	[bar]	4÷5	8÷9	12÷13	18÷20	24÷26	27÷32
Recommended opening pressure	[bar]	40					
Maximal opening pressure	[bar]	250					
Minimal volume of oil to control brake opening	[cm ³]	7÷8					
Mass	[kg]	10.5					
Recommended viscosity for the lubricant oil	[-]	ISO VG 150					
Maximal revs in input	[min ⁻¹]	1500					

		RF5-RFF5						
		RF5/21	RF5/29	RF5/43	RF5/65	RF5/85	RF5/110	RF5/130
		RFF5/21	RFF5/29	RFF5/43	RFF5/65	RFF5/85	RFF5/110	RFF5/130
Static torque	[Nm]	180÷230	280÷330	420÷460	610÷700	830÷920	1080÷1180	1260÷1360
Minimal opening pressure	[bar]	4÷5	6÷7	9÷10	13÷15	18÷20	23÷25	27÷29
Recommended opening pressure	[bar]	40						
Maximal opening pressure	[bar]	250						
Lubricating oil volume (Horizontal/Vertical)	[l]	0.30/0.60						
Minimal volume of oil to control brake opening	[cm ³]	8÷9						
Mass	[kg]	21						
Recommended viscosity for the lubricant oil	[-]	ISO VG 32						
Maximal revs in input	[min ⁻¹]	1000						

		RF170÷290			
		RF170	RF200	RF230	RF290
Static torque	[Nm]	1700	1980	2260	2830
Minimal opening pressure	[bar]	28÷30	24÷26	27÷29	28÷30
Recommended opening pressure	[bar]	40			
Maximal opening pressure	[bar]	250			
Lubricating oil volume (Horizontal/Vertical)	[l]	0.45/0.90			
Minimal volume of oil to control brake opening	[cm ³]	27÷30			
Mass	[kg]	64			
Recommended viscosity for the lubricant oil	[-]	ISO VG 32			
Maximal revs in input	[min ⁻¹]	750			

The RF2 series of brakes share lubrication with the reduction gear; for the RF 5, RFF 5 and RF 170÷290 series of brakes we recommend using hydraulic type mineral lubricants with an ISO VG 32 viscosity.

6.4 Friction shrink discs

Before starting to mount the friction shrink disc, the surfaces indicated with , that is the shaft centring surface (1a) and the inside surface of the hub (1b), must be cleaned and degreased thoroughly. The inside surface of the shrink disc (2a) and the outside surface of the hub (2b) also need cleaning and oiling slightly, making sure the oil does not reach surfaces 1a and 1b that have already been cleaned and degreased.

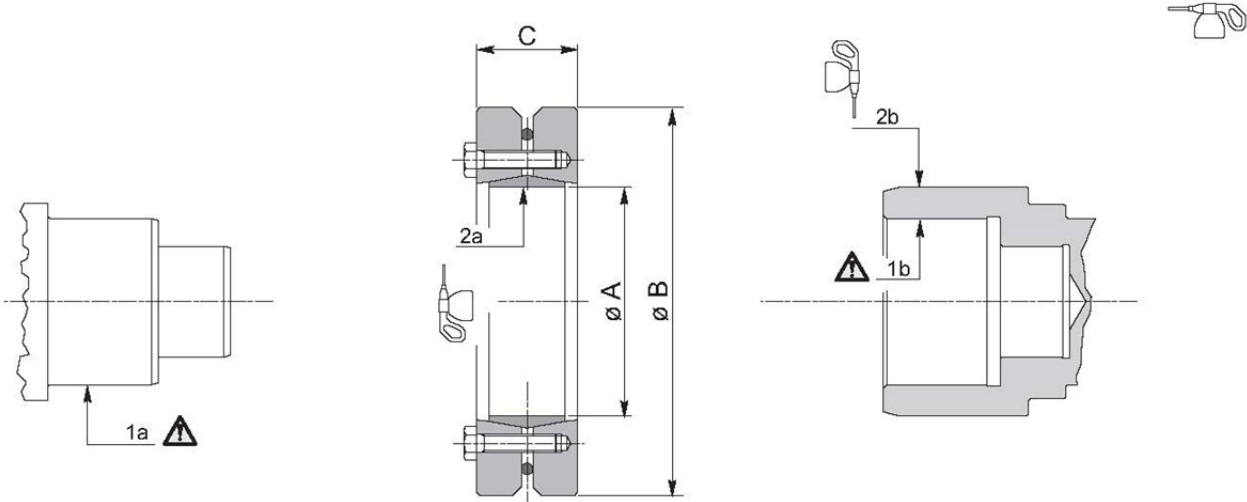

Only if the shrink disc is removed and then remounted must its conical surfaces as well as the shank and underneath of the screws' heads be cleaned and greased using a grease containing high pressure additives (MoS2).

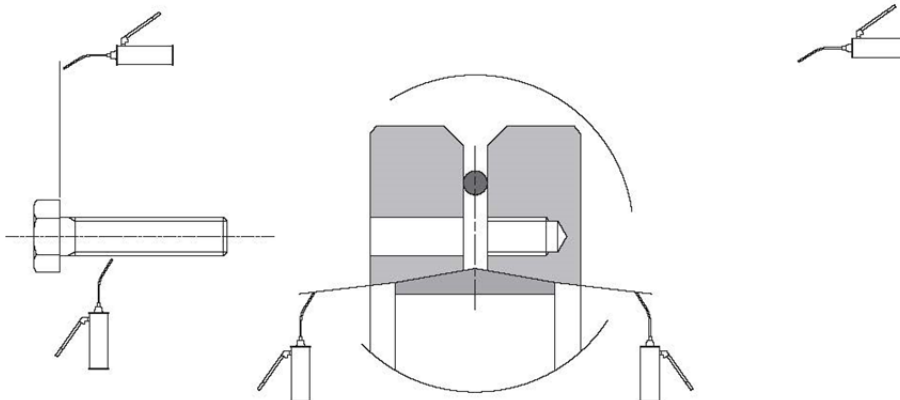

Tighten the screws to the torque given in the following table::

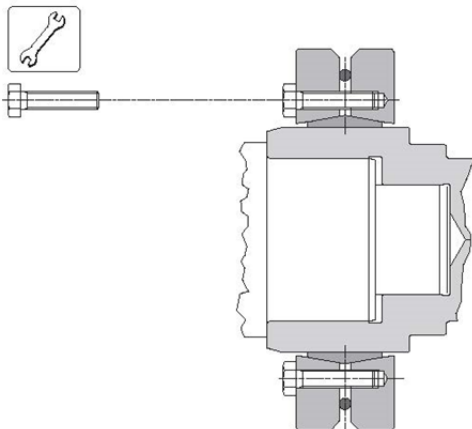

	 [Nm]
RR310 MH	30
RR510 MH	
RR710 MH	
RR810 MH	59
RR1010 MH	100
RR1700 MH	290
RR1700 BH	

6.5 Torque arms

Below are the dimensions recommended for implementing the torque arms, to use in combination with the friction shrink disc for reduction gears with an MH type output.

In the case of a single-fulcrum torque arm, it is essential to respect the H_{min} value, indicated in the table, and the 90° angle.

Before mounting, clean and degrease the resting tops and centring surfaces, which must be free from paint.

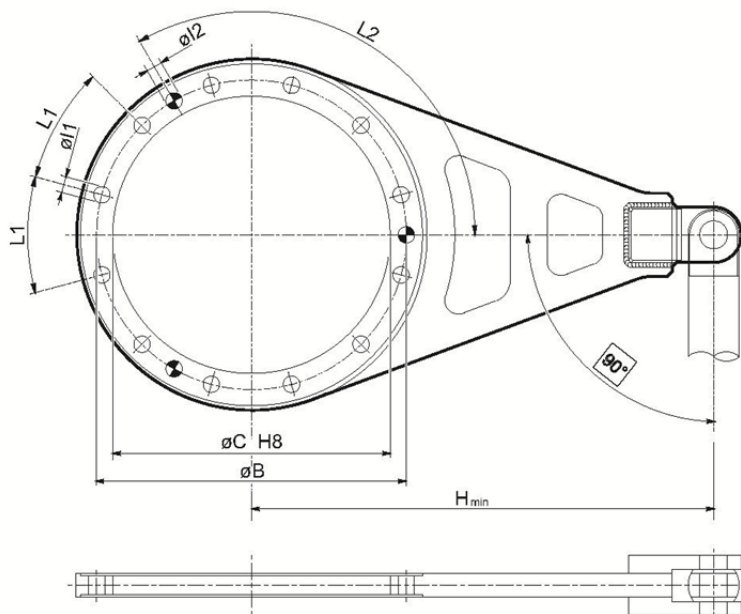

	B	C	H_{min}	I1	L1	I2	L2
RR310 MH	190	150	95	14.5 n°8	45°	-	-
RR510 MH RR710 MH	190	150	125	14.5 n°8	45°	-	-
RR810 MH	250	200	125	13 n°15	24°	-	-
RR1010 MH	295	230	147.5	14.5 n°12	30°	-	-
RR1700 MH	314	278	320	15 n°12	30°	12 n°3	120°
RR1700 BH	295	230	235	17 n°12	30°	-	-

7 LUBRICATION

Unless specified otherwise, all reduction gears are supplied without lubricant and inspected with a leak test as specified by a sticker; the user has to add the oil before start-up.



The lubricant oil inside a planetary reduction gear has the job of:

- reducing friction between the transmission parts, increasing their performance;
- helping to get rid of heat, transferring it from the moving parts to the casing;
- protecting surfaces from going rusty;
- reducing noise.



Correct lubrication ensures good operation and a long life of the reduction gear.

7.1 Viscosity

The lubricant's kinematic viscosity must be chosen in accordance with both the operating temperature and rotation speed.

Since viscosity diminishes as the temperature rises, for high operating temperatures it is advisable to choose a higher viscosity class oil.

In the case of very slow reductions (output speed n_2 below 5 min⁻¹) we recommend using a high viscosity class oil or, vice versa, in the case of reduction gears with a high rotation speed, we recommend using a low viscosity class oil.

7.2 Additives

The use of EP type additives (Extreme Pressure) helps reduce surface wear of the gears and bearings. As a matter of fact, these additives, under the effect of the heat and pressure between surfaces subject to load, react chemically with these same surfaces, forming a protective coating that prevents the formation of micro-weldings and consequent seizure.

7.3 Contamination

During the first hours of operation of the reduction gears, due to the contact between surfaces that have not been run-in, you will find metallic particles in the oil.

Undoubtedly these particles have a negative effect on the life of gears and bearings.

To reduce the number of metallic particles in the oil we recommend changing the oil and cleaning the magnetic plugs regularly, as explained further on in the maintenance chapter.

The recommended lubricants are listed in the following tables:

General purpose lubricants

Ambient temperature	Mineral oils			Poly-Alpha-Olefin synthetic oils (PAO)			Polyglycol synthetic oils(PG)		
	-10°C/+30°C	+10°C/+45°C	+30°C/+60°C	-20°C/+60°C			-20°C/+60°C		
Manufacturer	ISO VG 150	ISO VG 220	ISO VG 320	ISO VG 150	ISO VG 220	ISO VG 320	ISO VG 150	ISO VG 220	ISO VG 320
AGIP	Blasia 150	Blasia 220	Blasia 320	-	Blasia SX 220	Blasia SX 320	Blasia S 150	Blasia S 220	Blasia S 320
BP	Energol GR-XP150	Energol GR-XP220	Energol GR-XP320	Enersyn EPX150	Enersyn EPX220	Enersyn EPX320	Enersyn SG150	Enersyn SG-XP220	Enersyn SG-XP320
CASTROL	Alpha SP 150	Alpha SP 220	Alpha SP 320	Alphasyn EP 150	Alphasyn EP 220	Alphasyn EP 320	Alphasyn PG150	Alphasyn PG220	Alphasyn PG320
CHEVRON	Ultra Gear 150	Ultra Gear 220	Ultra Gear 320	Tegra Synthetic Gear 150	Tegra Synthetic Gear 220	Tegra Synthetic Gear 320	HiPerSYN 150	HiPerSYN 220	HiPerSYN 320
KLÜBER	Klüberoil GEM 1-150	Klüberoil GEM 1-220	Klüberoil GEM 1-320	Klübersynth EG 4-150	Klübersynth EG 4-220	Klübersynth EG 4-320	Klübersynth GH 6-150	Klübersynth GH 6-220	Klübersynth GH 6-320
MOBIL	Mobilgear XMP150	Mobilgear XMP220	Mobilgear XMP320	Mobilgear SHC Gear 150	Mobilgear SHC Gear 220	Mobilgear SHC Gear 320	Glygoyle 150	Glygoyle 220	Glygoyle 320
MOLIKOTE	L-0115	L-0122	L-0132	L-1115	L-1122	L-1132	-	-	-
SHELL	Omala S2 G 150	Omala S2 G 220	Omala S2 G 320	Omala S4 GX150	Omala S4 GX220	Omala S4 GX320	Omala S4 WE150	Omala S4 WE220	Omala S4 WE320
TEXACO	Meropa 150	Meropa 220	Meropa 320	Pinnacle EP 150	Pinnacle EP 220	Pinnacle EP 320	-	Synlube CLP220	Synlube CLP320
TOTAL	Carter EP 150	Carter EP 220	Carter EP 320	Carter SH 150	Carter SH 220	Carter SH 320	Carter SY 150	Carter SY 220	Carter SY 320
TRIBOL	1100/150	1100/220	1100/320	1510/150	1510/220	1510/320	800\150	800\220	800\320

Food grade lubricants

Manufacturer	Hydraulic oils			Gear oils		
	ISO VG 32	ISO VG 46	ISO VG 68	ISO VG 150	ISO VG 220	ISO VG 320
AGIP	Rocol Foodlube Hi Power 32	-	-	Rocol Foodlube Hi-Torque 150	-	Rocol Foodlube Hi-Torque 320
BP	Enerpar M 32	Enerpar M 46	Enerpar M 68	-	-	-
KLÜBER	Summit Hysyn FG 32	Summit Hysyn FG 46	Summit Hysyn FG 68	Klüberoil 4 UH1 N 150	Klüberoil 4 UH1 N 220	Klüberoil 4 UH1 N 320
MOBIL	DTE FM 32	DTE FM 46	DTE FM 68	DTE FM 150	DTE FM 220	DTE FM 320
SHELL	Cassida Fluid HF 32	Cassida Fluid HF 46	Cassida Fluid HF 68	Cassida Fluid GL 150	Cassida Fluid GL 220	Cassida Fluid GL 320
TEXACO	Cygnus Hydraulic Oil 32	Cygnus Hydraulic Oil 46	Cygnus Hydraulic Oil 68	Cygnus Gear PAO 150	Cygnus Gear PAO 220	-
TOTAL	Nevastane AW 32	Nevastane AW 46	Nevastane AW 68	Nevastane SL 150	Nevastane SL 220	Nevastane SL 320
TRIBOL	Food Proof 1840/32	Food Proof 1840/46	Food Proof 1840/68	-	Food Proof 1810/220	Food Proof 1810/320

If other synthetic lubricants are used always check their compatibility with the NBR oil seals used in the reduction gear.



Do not mix different kinds of synthetic lubricant together.



Use synthetic lubricants only for reduction gears that are going to be used in a potentially explosive atmosphere.

If the working conditions of the reduction gear entail prolonged working periods such that the oil gets very hot (>60°C) we recommend using synthetic oil to guarantee less wear of the components and also for longer intervals between changing it.

The maximum temperature of the lubricant inside the reduction gear should not exceed 90°C.

7.4 Assembly position and where the plugs are located

You can see the possible assembly positions in the figures below. The relative initial must be specified when ordering the reduction gear.

The layout and type of plugs as well as the minimum lubricant level are also indicated, as per legend.

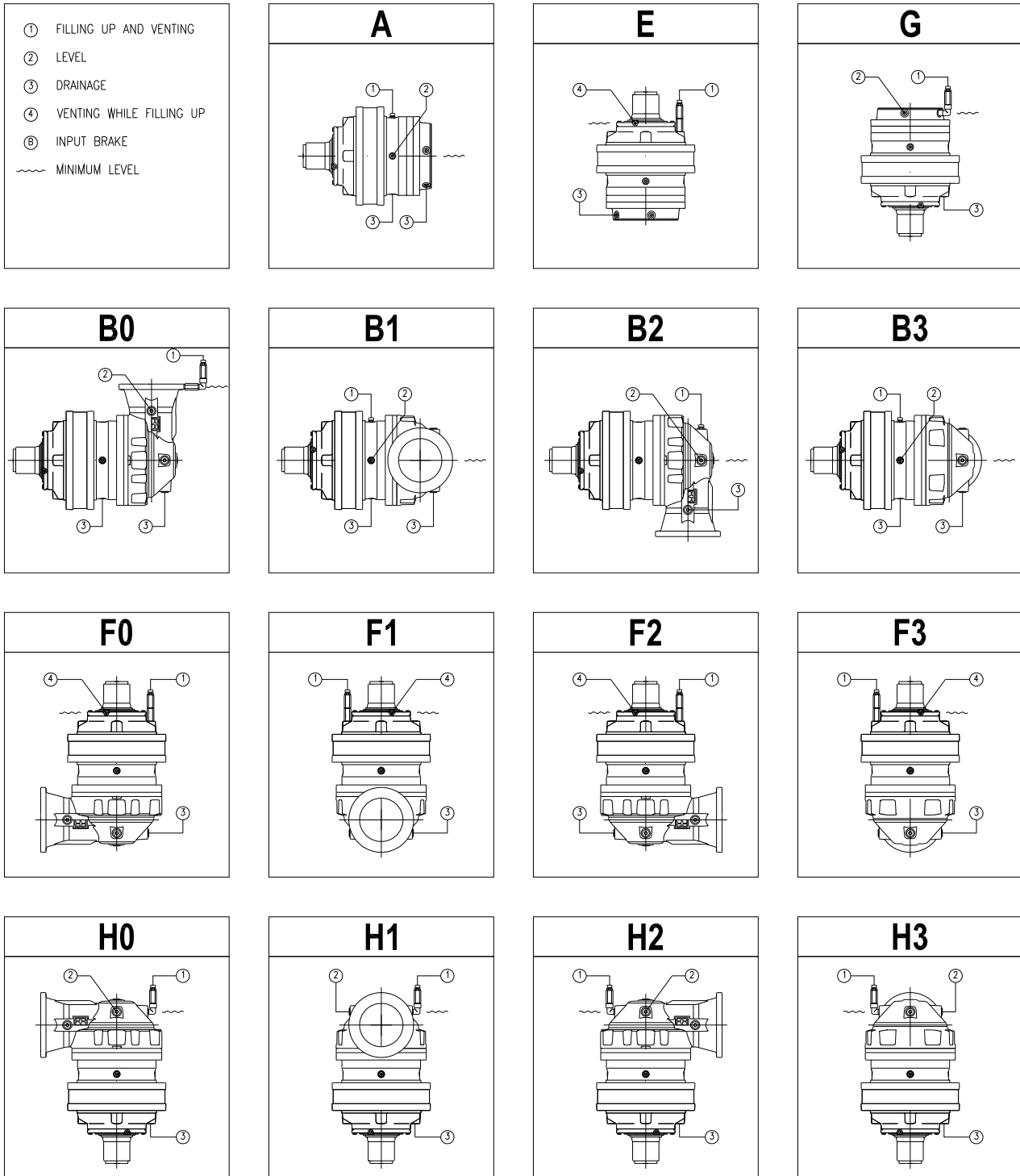

BRAKE

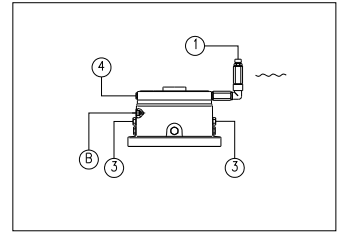
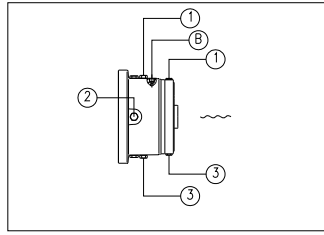
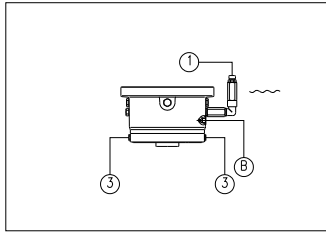

L INPUT

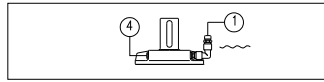
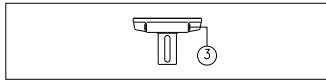

M INPUT

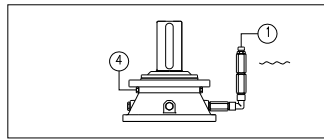
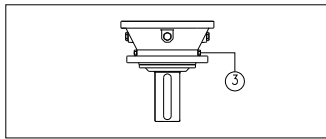

P INPUT

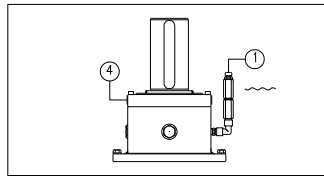
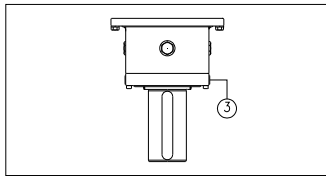

7.5 Filling up

For the assembly positions A, B1, B2 and B3 fill up to the halfway point of the reduction gear; the right level of the lubricant can be checked with the level plugs, indicated with (2) in the previous figure.

For applications with low output rotation speeds ($n_2 \leq 5\text{rpm}$) we advise you to fill the reduction gear with oil to $\frac{3}{4}$ of the total volume.

For very low output rotation speeds ($n_2 \leq 1\text{rpm}$) or when storing for long periods of time, fill the reduction gear completely with oil. In this case, use an expansion tank to allow the oil volume to increase according to temperature.

For the assembly positions E, G, B0, F0, F1, F2, F3, H0, H1, H2 and H3, they have to be filled right up to the top to allow correct lubrication of the components situated at the upper most part of the reduction gear. In this case, when filling up, you have to remove at least one of the plugs from the upper most part of the reduction gear, indicated with (4) in the previous figure, so as to prevent air bubbles forming.

As the lubricant increases in volume with the rising temperature, when the reduction gear is working in the completely filled conditions it is necessary to have a tank that allows the oil to expand and thus reduce the risk of high pressures being created inside the reduction gear itself.

To facilitate filling up and, at the same time, allow the oil to expand, expansion tanks are available on request with different capacities and supplied in complete kits. These expansion tanks can be connected to the reduction gear with a rigid connection or flexible pipes.

The expansion tank must always be placed so the level of oil, which can be seen by means of a small transparent tube placed in parallel with the tank for instance (standard in some kits), is above the highest point you wish to lubricate and, hence, above the venting plugs (4).

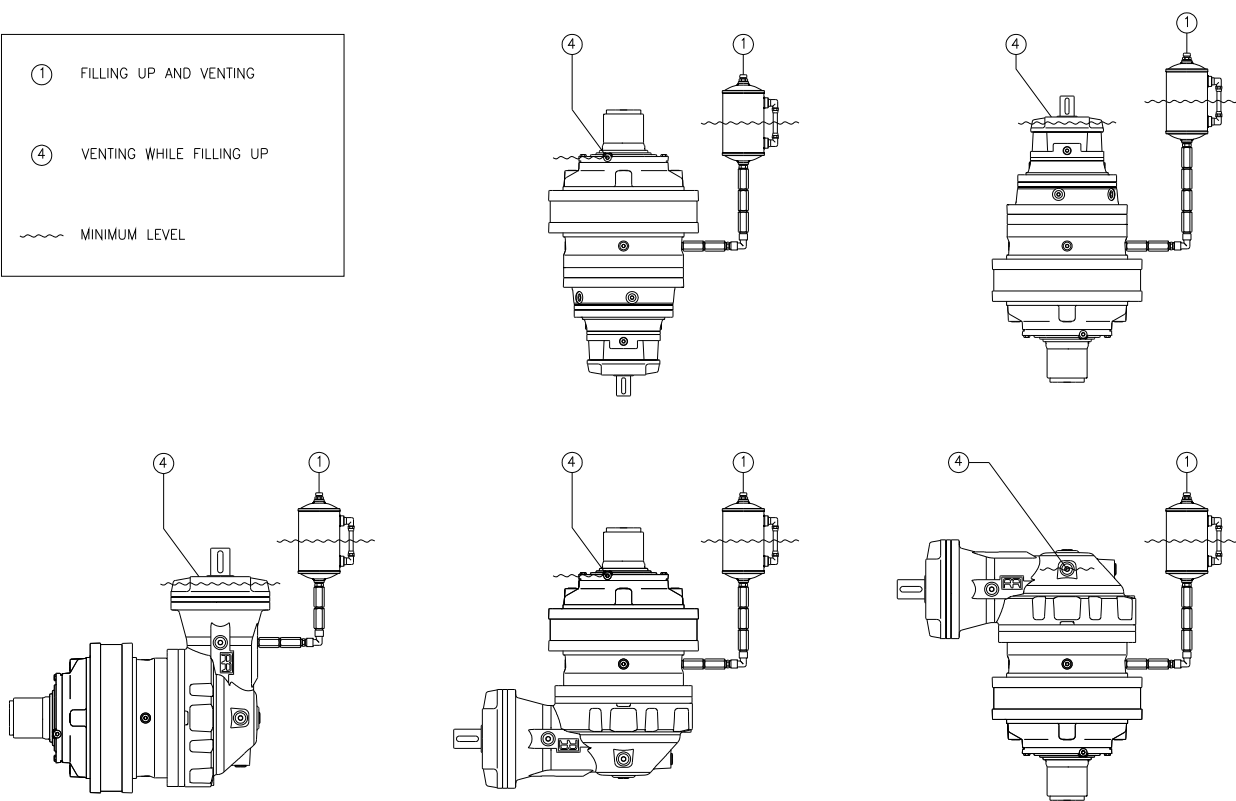
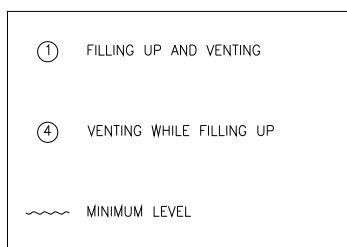

Please refer to the following table and relative figure for the sales codes and technical specifications of the tank kits.

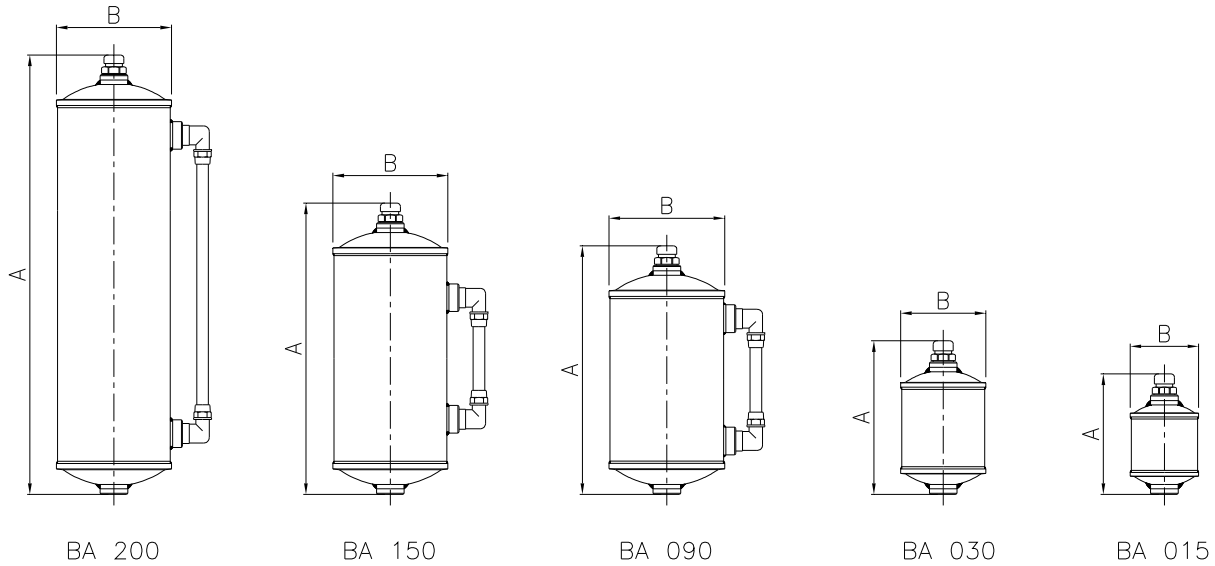

TYPE	A	B	Oil capacity [litres]	Code of the complete kit	Tank code
BA 015	110	Ø 65	~ 0.15	154-5764	154F1562
BA 030	140	Ø 80	~ 0.30	154-5749	154F1563
BA 090	225	Ø 104	~ 0.90	154-5733	154F1561
BA 150	265	Ø 104	~ 1.50	154F5986	154F5988
BA 200	400	Ø 104	~ 2.00	154F5987	154F5989

The choice of tank should be based on the volume of expanded oil V_e ; this can be found in the following way: in the following graph, find the point which has for the abscissa the Δt difference between the reduction gear's oil temperature and ambient temperature and for the ordinate the volume V of oil necessary to fill the reduction gear. On the basis of the area in which the point falls, you find the volume of expanded oil V_e and the tank is sized for double the volume calculated.

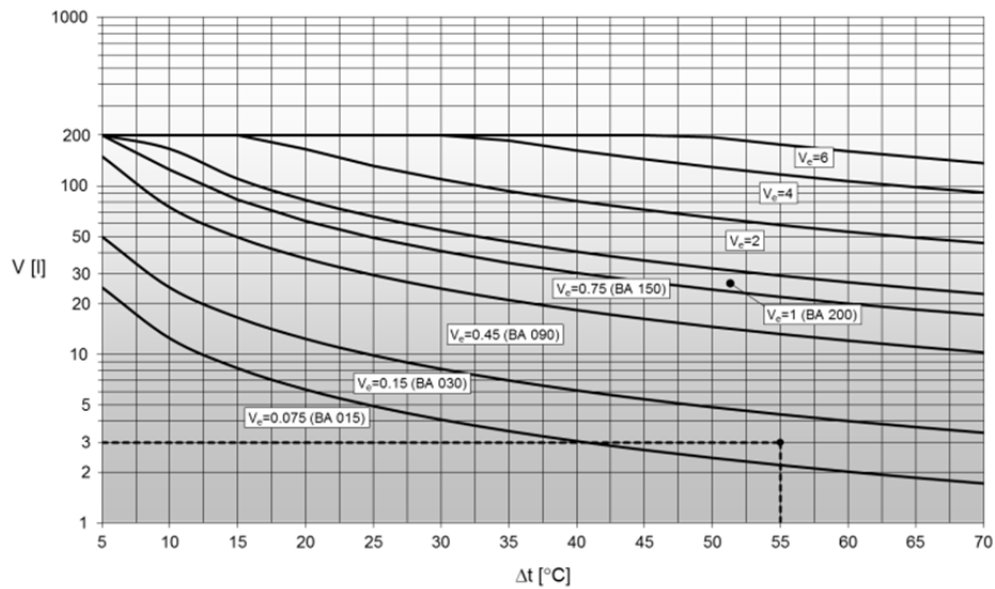

Example

Consider a reduction gear with an oil capacity of 3 litres at an operating temperature of 80°C and with an ambient temperature of 25°C. Finding the abscissa $\Delta t = 80 - 25 = 55^\circ\text{C}$ and ordinate $V = 3$ litres point on the graph, it belongs to the area with an expanded volume of $V_e = 0.15$ litres. The tank recommended should have a volume double that of V_e – that is 0.30 litres – so the ideal tank is the BA 030.

On the following pages you will find the volumes of oil, purely indicative, necessary to fill up according to the assembly position. For any data you cannot find, please contact the **Reggiana Riduttori** Technical service.

TYPE	OIL VOLUME [l]		MASS [kg]
	POSITION		
	A	E - G	
RR 65 M...	0.1	0.2	7
RR 65 FS	0.1	0.2	3.5
RR 65D M...	0.1	0.3	10
RR 65D FS	0.1	0.2	5.5
RR 65T M...	0.2	0.3	12
RR 65T FS	0.1	0.3	6.8
RR 105 M...	0.5	0.9	14
RR 105 FS	0.4	0.8	8
RR 105D M...	0.3	0.6	20
RR 105D FS	0.2	0.5	9
RR 105T M...	0.3	0.7	21
RR 105T FS	0.2	0.5	14
RR 110 M...	0.5	0.9	11
RR 110 FS	0.4	0.8	7.5
RR 110D M...	0.3	0.6	15
RR 110D FS	0.2	0.5	9
RR 110T M...	0.3	0.7	18
RR 110T FS	0.2	0.5	15
RR 210 M...	0.5	0.9	24
RR 210 S...	0.5	1	21
RR 210 FS	0.4	0.8	9
RR 210D M...	0.6	1.2	25
RR 210D S...	0.6	1.2	25
RR 210D FS	0.5	1	14
RR 210T M...	0.4	0.9	27
RR 210T S...	0.5	0.9	49
RR 210T FS	0.4	0.7	22
RR 210Q M...	0.5	0.9	28
RR 210Q S...	0.5	0.9	50
RR 210Q FS	0.4	0.7	23
RR 310 M...	1.1	2.1	21
RR 310 S...	1.5	3	43
RR 310 FS	0.7	1.5	20
RR 310D M...	1.2	2.4	36
RR 310D S...	1.7	3.3	47
RR 310D FS	0.9	1.8	23
RR 310T M...	1.1	2.1	38
RR 310T S...	1.5	3	49
RR 310T FS	0.7	1.5	26.5

TYPE	OIL VOLUME [l]		MASS [kg]
	POSITION		
	B0 - F0 - F1 - F2 - F3 - H0 - H1 - H2 - H3	B1 - B2 - B3	
RA 105 M...	2.4	1.2	33
RA 105 FS	2.2	1.1	30
RA 105D M...	2.1	1	37
RA 105D FS	1.9	0.9	32
RA 110 M...	2.4	1.2	33
RA 110 FS	2.2	1.1	31
RA 110D M...	2.1	1	35
RA 110D FS	1.9	0.9	32
RA 210 M...	2.4	1.2	32
RA 210 S...	2.4	1.2	38
RA 210 FS	2.2	1.1	33
RA 210D M...	2.6	1.3	35
RA 210D S...	2.7	1.3	42
RA 210D FS	2.4	1.2	34
RA 310 M...	3.6	1.8	46.5
RA 310 S...	4.5	2.2	57.6
RA 310 FS	2.9	1.5	40
RA 310D M...	3.9	1.9	52
RA 310D S...	4.8	2.4	61
RA 310D FS	3.2	1.6	42.5
RA 310T M...	3.6	1.8	56
RA 310T S...	4.5	2.2	65
RA 310T FS	2.9	1.4	45
RA 510 M...	6.5	3.3	81
RA 510 S...	7.4	3.7	92
RA 510 FS	5.8	2.9	70
RA 510D M...	4.2	2.1	59
RA 510D S...	5.2	2.6	77
RA 510D FS	3.6	1.8	55
RA 510T M...	4.5	2.3	62
RA 510T S...	5.4	2.7	78
RA 510T FS	3.9	1.9	57
RA 710 M...	6.5	3.2	74
RA 710 S...	7.3	3.6	92
RA 710 FS	5.8	2.9	72
RA 710D M...	4.2	2.1	77
RA 710D S...	5	2.5	73
RA 710D FS	3.5	1.8	52
RA 710T M...	4.5	2.3	78

TYPE	OIL VOLUME [l]		MASS [kg]
	POSITION		
	A	E - G	
RR 310Q M...	1.1	2.1	41
RR 310Q S...	1.5	3	53
RR 310Q FS	0.7	1.5	29.5
RR 510 M...	0.9	1.8	35
RR 510 S...	1.4	2.7	44
RR 510 FS	0.6	1.2	28
RR 510D M...	1.4	2.8	52
RR 510D S...	1.9	3.7	60
RR 510D FS	1.1	2.1	37
RR 510D VI	-	2.5	51
RR 510T M...	1.5	3.1	55
RR 510T S...	2	4	61
RR 510T FS	1.2	2.4	39
RR510T VI	-	2.8	54
RR 510Q M...	1.4	2.8	59
RR 510Q S...	1.9	3.7	65
RR 510Q FS	1.1	2.1	49
RR 510Q VI	-	2.5	58
RR 710 M...	0.9	1.8	34
RR 710 S...	1.3	2.6	48
RR 710 FS	0.6	1.1	23
RR 710D M...	1.4	2.8	54
RR 710D S...	1.8	3.6	62
RR 710D FS	1	2.1	37
RR 710D VI	-	2.6	50
RR 710T M...	1.5	3.1	56
RR 710T S...	1.9	3.8	67
RR 710T FS	1.2	2.4	39
RR 710T VI	-	2.9	52
RR 710Q M...	1.4	2.8	64
RR 710Q S...	1.8	3.5	75
RR 710Q FS	1	2.1	47
RR 710Q VI	-	2.6	60
RR 810 M...	1.9	3.8	64
RR 810 S...	2	4	70
RR 810 FS	1.4	2.8	41
RR 810D M...	2.1	4.1	77
RR 810D S...	2.1	4.3	81
RR 810D FS	1.6	3.1	61
RR 810D VI	-	5.9	81
RR 810D ZI	-	5.9	87

TYPE	OIL VOLUME [l]		MASS [kg]
	POSITION		
	B0 - F0 - F1 - F2 - F3 - H0 - H1 - H2 - H3	B1 - B2 - B3	
RA 710T S...	5.3	2.6	85
RA 710T FS	3.8	1.9	57
RA 810 M...	8.5	4.3	111
RA 810 S...	8.7	4.3	117
RA 810 FS	7.5	3.8	82
RA 810D M...	5.5	2.8	74
RA 810D S...	5.7	2.9	98
RA 810D FS	4.6	2.3	57
RA 810T M...	5.8	2.9	77
RA 810T S...	6	3	103
RA 810T FS	4.8	2.4	90
RA 1010 (A) M...	10.1	5	124
RA 1010 (A) FS	8.1	4.1	90
RA 1010 (B) M...	13.8	6.9	161
RA 1010 (B) FS	11.9	5.9	133
RA 1010D M...	10	5	143
RA 1010D FS	8.1	4.1	109
RA 1010T M...	7.8	3.9	148
RA 1010T FS	5.9	2.9	94
RA 1700 (A) B...	10.4	5.2	227
RA 1700 (A) M...	11.1	5.6	160
RA 1700 (A) FS	8.5	4.2	100
RA 1700 (B) B...	14.1	7	177
RA 1700 (B) M...	14.9	7.4	171
RA 1700 (B) FS	12.2	6.1	144
RA 1700D B...	10.3	5.2	179
RA 1700D M...	11.1	5.6	179
RA 1700D FS	8.5	4.2	119
RA 1700T B...	8.1	4	155
RA 1700T M...	8.8	4.4	157
RA 1700T FS	6.2	3.1	104

TYPO	OIL VOLUME [l]		MASS [kg]
	POSITION		
	A	E - G	
RR 810T M...	2.2	4.4	83
RR 810T S...	2.3	4.5	86
RR 810T FS	1.7	3.4	63
RR 810T VI	-	6.2	87
RR 810T ZI	-	6.2	93
RR 810Q M...	2	4.1	87
RR 810Q S...	2.1	4.2	94
RR 810Q FS	1.6	3.1	66
RR 810Q VI	-	5.9	91
RR 810Q ZI	-	5.9	97
RR 1010 M...	2.7	5.4	82
RR 1010 FS	1.7	3.5	53
RR 1010D M...	2.7	5.4	100
RR 1010D FS	1.7	3.5	77
RR 1010D VI	-	9.2	108
RR 1010D ZI	-	9.2	122
RR 1010T M...	3.2	6.3	121
RR 1010T FS	2.2	4.4	99
RR 1010T VI	-	10.2	129
RR 1010T ZI	-	10.2	143
RR 1010Q M...	3.3	6.6	124
RR 1010Q FS	2.4	4.7	102
RR 1010Q VI	-	10.5	132
RR 1010Q ZI	-	10.5	146
RR 1700 B...	2.8	5.7	112
RR 1700 M...	3.2	6.5	88
RR 1700 FS	1.9	3.8	70
RR 1700D B...	2.8	5.7	136
RR 1700D M...	3.2	6.4	105
RR 1700D FS	1.9	3.8	89
RR 1700D VI	-	9.5	125
RR 1700D ZI	-	9.5	137
RR 1700T B...	3.3	6.6	147
RR 1700T M...	3.7	7.4	120
RR 1700T FS	2.4	4.8	105
RR 1700T VI	-	10.5	140
RR 1700T ZI	-	10.5	152
RR 1700Q B...	3.5	6.9	148
RR 1700Q M...	3.8	7.7	131
RR 1700Q FS	2.5	5.1	106
RR 1700Q VI	-	10.8	141
RR 1700Q ZI	-	10.8	153

7.6 Auxiliary cooling systems



Connection of the electrical contacts and hydraulic circuit and all the material needed for it are the responsibility of the customer.

The hydraulic connection of the auxiliary cooling system must be done so as to intake the oil (and any detritus) from the lowest point (point (3) in the assembly positions figures) and have the delivery from a point far enough away from the intake to facilitate changing the oil from inside the reduction gear. If the intake hole is not big enough to get rid of the pump's flow, 2 or more intake points must be foreseen to guarantee against the risk of cavitation. 2 or more connection holes may also be used for delivery, for example, in the case of multi-stage reduction gears.

The figure gives a few examples of connecting the auxiliary cooling system to the reduction gear, where you can see the intake and delivery hydraulic connections as well as the electrical connections of the thermostats that regulate system operation.

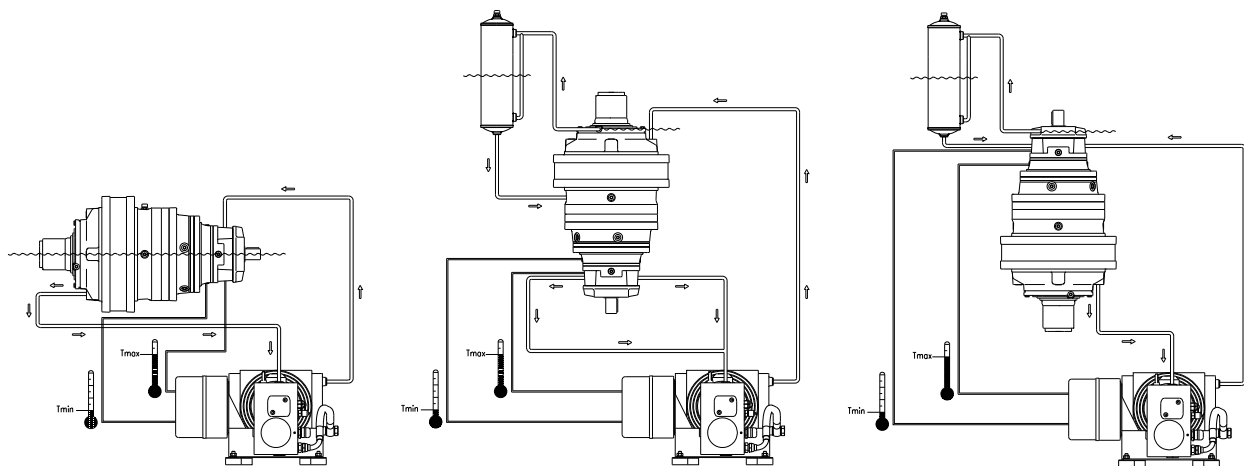

The size of the delivery pipes must take into account the distance between the cooling unit and the reduction gear, being careful not to exceed an overall line pressure drop of 2-3 bar in the operating temperature range (30°C +90°C).

The maximum permitted pressure inside the reduction gear is 0.5 bar.

In addition, for the assembly positions with a vertical axis and, of course, wherever the reduction gear is filled up completely with lubricant, an expansion tank has to be mounted.

In these cases we recommend using the BA 200 expansion tank.

8 COMMISSIONING

8.1 Inspection

Before using the reduction gear under load, turn the motor on and check:

- that the reduction gear output is rotating;
- that rotation direction is as specified in the project;
- there is no lubricant leaking;
- there is no unusual noise and/or vibrations.

In addition, if there is a negative brake check that:

- when the brake command is powered at the minimum pressure indicated, the brake does actually open;
- the brake is able to stop the machine under the load conditions as established in the project.



Verify that all guards are installed to prevent accidental contact between operators and the unit's rotary moving parts.

8.2 Control of the surface temperature



When starting up for the very first time it is necessary to check the surface temperature under normal operating conditions.

The temperature must be measured under the following conditions:

- ambient temperature no higher than +40°C;
- continuous operation at full load for a minimum time of 4 hours;
- there must be no potentially explosive atmosphere.

Generally speaking, the surface area that is normally hotter is the reduction gear inlet, indicated in the figure by the dotted lines.

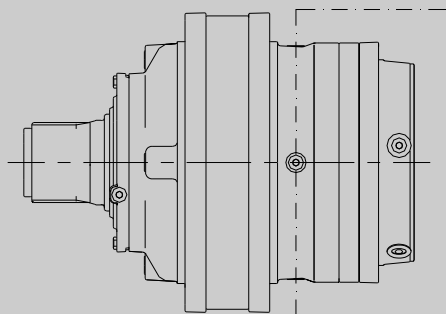

If a negative brake is used, measure the temperature on the body of the brake, by its disks.

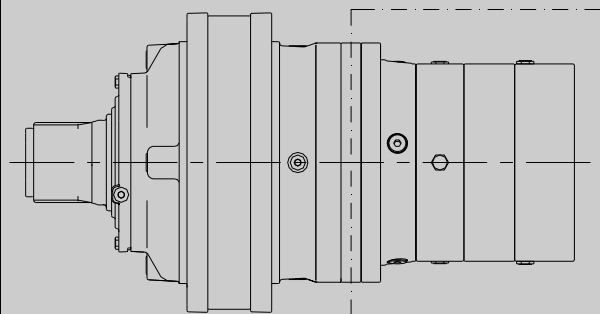

Also check there are no anomalous temperatures in the areas in proximity of the bearings.

If the temperature exceeds 130°C stop the machine immediately and contact the Reggiana Riduttori Assistance service.

9 MAINTENANCE

9.1 Cleaning

Periodically remove dust from the reduction gear. Do not use solvents or other products that are incompatible with the construction materials. Do not aim blasts of high pressure water at the reduction gear.



Periodically clean the outer surface of the reduction gear and recesses; do not let dust collect any higher than 5 mm.

9.2 Routine maintenance

Routine maintenance is to be carried out by the end user.



Maintenance must be carried out by a person working in compliance with the accident prevention rules so as to guarantee his safety and that of the other people in the vicinity.

Before starting any maintenance work, make certain the machine the reduction gear is connected to is off and it is impossible for it to be switched back on accidentally.

Danger burns: do not touch the gear unit during operation and cooling down phase after switching off.

Use suitable tools, in good condition, to remove and mount the components.

After the first 100 hours of operation:

- change the oil;
- clean the plugs;
- remove all metal residuals from the magnetic plug, making sure there are no big fragments; if there are, contact the **Reggiana Riduttori** Assistance service;
- check tightness of all the screws.

To change the oil, place a tray underneath in which to collect the waste oil and unscrew the filling up and draining plugs.

Wait a few minutes until all the oil has drained off and then screw the drain plug back on, replacing the seal. Put the new oil in (do not mix oils of different brands or properties) up to the level foreseen and then screw the filling up plug back on, replacing the seal.

Change the oil when the reduction gear is still hot as this makes it easier to empty the oil completely, avoiding the formation of oil foots.

Every 500 hours of operation:

- visually check the oil level by way of the plugs;
- check the condition of the external seals and make sure there are no leaks. If there are, replace the seals, using original spare parts;
- check tightness of all the screws.

Every 2000 hours of operation or at least once every 12 months:

- change the oil;
- clean the plugs;
- check tightness of all the screws.



If you should find the level of the lubricant increases on a reduction gear with a negative brake and hydraulic motor, oil could be leaking from the brake seals or from the motor's rotating seal; in such an event, contact the **Reggiana Riduttori** Assistance service.



Before starting any maintenance work, make certain there is no potentially explosive atmosphere.

Maintenance must be carried out by a person working in compliance with the accident prevention rules so as to guarantee his safety and that of the other people in the vicinity.

Every 1000 hours of operation:

- check the surface temperature in the area found to be hottest during the inspection. The maximum temperature reached must be below the temperature given on the data plate for the specific category of use (Gas/Powder).

If the temperature exceeds 130°C stop the machine immediately and contact the **Reggiana Riduttori** Assistance service.

Every 5000 hours of operation:

- check and/or replace the seals in case of wear/ageing;

9.3 Extraordinary maintenance

Extraordinary maintenance is the competence of the **Reggiana Riduttori** Assistance service, therefore it is prohibited to open the reduction gear for any type of operation that does not fall within the category of those defined as "routine maintenance".

If repairs by the end user are agreed, such repairs must be done by an expert Maintenance Engineer.

Reggiana Riduttori cannot be held liable for any operations carried out, that are not part of routine maintenance or not agreed upon beforehand with the Customer, that have caused injury to people or damage to things.

9.4 Repacking

If the reduction gear needs repairing and has to be shipped to the Assistance service the packaging used must be similar to the one it was delivered in.

10 DECOMMISSIONING THE PRODUCT

Expert personnel must see to the decommissioning operations in compliance with current rules and regulations on safety at the work place.

We suggest proceeding in the following way:

- drain off all oil from inside the reduction gear;
- disconnect the motor, if any;
- remove the components.

The above operations must be done observing the current laws concerning the environment, doing everything possible not to contaminate the ground, water or air with non-biodegradable products.

All the components removed when decommissioning the reduction gear must be handed over to authorised collection centres for treatment, recycling and disposal of non-biodegradable waste.

11 TROUBLESHOOTING

Should an anomaly occur during operation consult the following table. If the problem persists, contact the closest **Reggiana Riduttori** Assistance service.

ANOMALY	POSSIBLE CAUSE	SOLUTION
Oil leakage from the seals	Hardening of the seals due to prolonged storing	Clean the area and check for leakage after a few hours of operation
	Seals damaged or worn	Contact an Assistance Centre
Vibrations and/or excessive noise	Reduction gear not installed correctly	Check the fixing
	Internal anomaly	Contact an Assistance Centre
The stationing brake fails to disengage	Lack of pressure in the brake	Check the brake connection
	Disks stuck due to the period of stationing	Apply pressure and put the brake inlet in rotation
	Brake seals faulty	Contact an Assistance Centre
Over-heating	Lack of oil	Add oil
	The brake does not completely open	Check opening pressure
	High thermal power	Contact an Assistance Centre
With motor activated the reduction gear does not rotate	Incorrect mounting of motor	Check coupling between motor and reduction gear
	Brake blocked	Check the braking system
	Internal anomaly	Contact an Assistance Centre
Stationing brake does not block	Residual pressure in the circuit	Check hydraulic circuit
	Disks worn	Contact an Assistance Centre