

# J125B

Service Regulator  
Inlet Pressure up to 8.6 bar  
Nominal Diameter 1½" & 2"

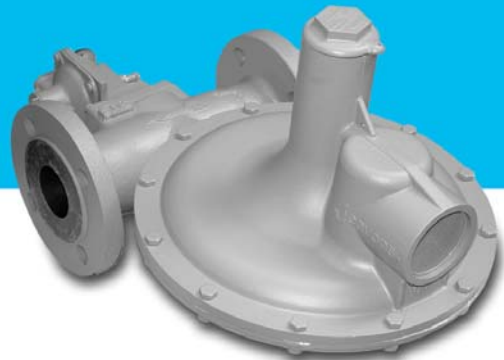

## Applications

- Industrial
- Commercial
- Residential

## Brief information

**Operation:** The J125B series provides a full range of regulators for service applications where accurate pressure control and high flow rates are required. The units are ideal for industrial pressure reducing, metering stations and for district distribution. The regulators are designed to maintain high accuracy and efficiency over the inlet pressures up to 8.6 Bar (125 PSIG). Available with screwed connections, sizes 1½" and 2", and 50mm flanged connections.

Because of the special balanced valve design the regulator maintains control of the outlet pressure over the full inlet pressure range whilst using the largest orifice size available, giving a very high flow rate. The comprehensive range of outlet pressure springs are the same as that of the standard J125.

The unit has been designed for ease of installation and servicing. The diaphragm case can be fully rotated and is easy to remove.

The J125B can be fitted with a full or limited capacity relief valve. It is recommended that the unit is fitted with the Jeavons Universal Safety Shut-off Assembly (USSA). This provides over pressure and/or under pressure protection with immediate shut-off at the regulator inlet. It uses well proven principles to give exceptional consistency of operation and an unrivalled insensitivity to nuisance tripping.

**Application:** All units are suitable for operation on natural, liquid petroleum and manufactured gases. Various versions of this regulator comply with the requirements of BGC/PS/E26 & IGE/TD/10. The USSA unit is designed to meet the requirements of the standards BGES/V9 & DIN3381.

### Technical Data:

Maximum inlet pressure:	8.6 Bar (125 psig)
Maximum outlet Pressure:	350mbar (5 psig)
OPSS range:	18 - 500mbar (7.5"wg – 7 psig)
UPSS range:	8 - 150mbar (3 – 60 "wg)

**Approval:** The 1½" and 2" J125B have been approved to Modules B + D of the PED 97/23/EC by BSI (Notified Body No. 0086). It is classified as Category IV equipment and a pressure accessory.

**Servicing:** The J125B has been designed for ease of access, inspection and servicing of all internal components. A standard soft spares kit is available for all sizes.

J125B-S1 & S3	reference number SK2529-08
J125B-S2	reference number SK2529-09
J125B-S4, S6 & S8	reference number SK2529-10
J125B-S5, S7, S9, S10, S11 & S12	reference number SK2529-11

## Main features

- Sizes 1½", 2" & 50mm
- Temperature range -20°C to +70°C
- Threaded connections to BS EN 10226 (ISO 7) or NPT. Flanged to BS EN 1092-2 NP16 or ANSI (other connection standards may be available upon request)
- External impulse
- Spring loaded
- High flow capacity
- Excellent outlet pressure control

## Options

- Full or limited relief valve
- Over pressure slam shut
- Under pressure slam shut



# J125B: Service Regulator

## Schematic Installation

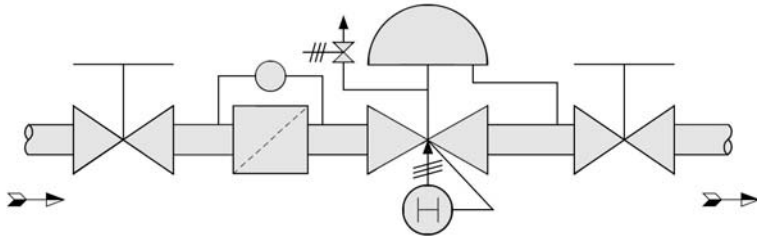

## Relief Valve

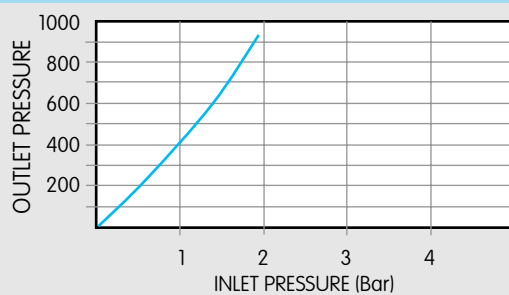

The data represented in the graph left shows the rise in outlet pressure above the set point against change in inlet pressure at a full fault situation.

## Regulator Springs

mbar	"wg	Part Number	Colour Code
8.8 - 15	3.5 - 6	J12509-091	Red
14 - 20	5.5 - 8	J12509-092	Orange
21 - 35	8.5 - 14	J12509-093	Yellow
36 - 70	14.5 - 28	J12509-094	Green
69 - 138	1 - 2 PSI	J12509-095	Royal Blue
104 - 173	1.5 - 2.5 PSI	J12509-096	Brown / Royal Blue
138 - 207	2 - 3 PSI	J12509-097	Brown / Green
207 - 350	3 - 5 PSI	J12509-098	Black / Green

## OPSS Springs

mbar	"wg	Part Number	Colour Code
18 - 60	7.5 - 24	J12506-281	Black
50 - 80	20 - 32	J12506-282	Orange
60 - 110	24 - 44	J12506-283	Red
100 - 210	40 - 84	J12506-284	Dark Green
200 - 350	3 - 5 PSI	J12506-287	Yellow
280 - 500	4 - 7 PSI	J12506-288	White

## UPSS Springs

mbar	"wg	Part Number	Colour Code
8 - 16	3 - 6	J12506-285	Light Blue
16 - 60	6 - 24	J12506-286	Brown
60 - 150	24 - 60	J12506-289	Purple

# J125B: Service Regulator

TYPE	Full Capacity Relief (FR)	Limited Capacity Relief (LR)	Over Pressure Slam Shut (OPSS)	Under Pressure Slam Shut (UPSS)	Unit Weight (Kg)	
					Screwed	Flanged
J125B-S1					10.7	16.8
J125B-S2	*				10.7	16.8
J125B-S3		*			10.7	16.8
J125B-S4	*		*		11.2	17.3
J125B-S5		*	*		11.2	17.3
J125B-S6	*			*	11.2	17.3
J125B-S7		*		*	11.2	17.3
J125B-S8	*		*	*	11.2	17.3
J125B-S9		*	*	*	11.2	17.3
J125B-S10			*		11.2	17.3
J125B-S11				*	11.2	17.3
J125B-S12			*	*	11.2	17.3

## Dimensions

J125B S1/S2/S3 Screwed

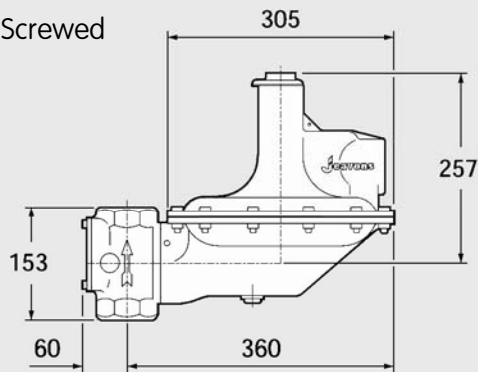

J125B S1/S2/S3 Flanged

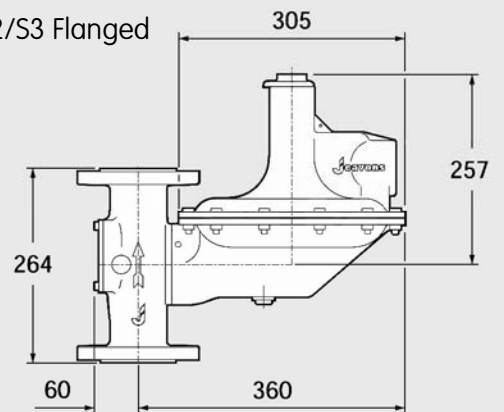

J125B S4 – S12 Screwed

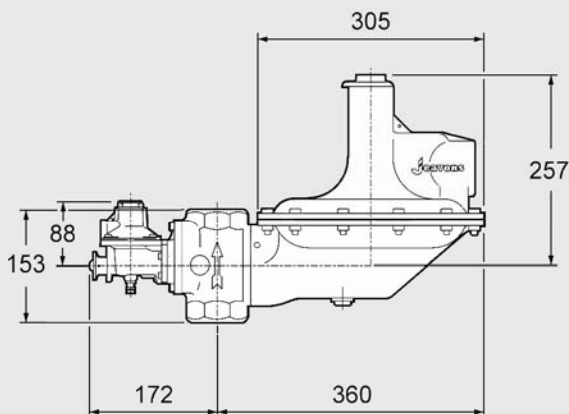

J125B S4 – S14 Flanged

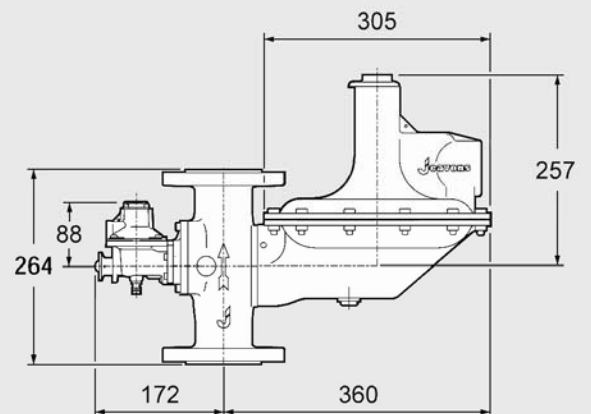

# J125B: Service Regulator

## Regulating Capacities – 1½" Size

All capacities in SCMH 0.64 s.g. Droop = 20%

Spring Range (mbar)	8.8 - 15	14 - 20	21 - 35	36 - 70	69 - 138	104 - 173	138 - 207	207 - 350
Setting Pressure (mbar)	15	17.5	35	60	100	150	200	345
Inlet Pressure (mbar)								
350	195	202	163	280	178	192	158	-
689	400	495	342	436	379	350	382	243
1000	470	583	476	490	356	448	456	308
1500	490	592	492	500	386	456	468	412
2000	472	553	458	478	354	492	440	402
3000	612	685	624	455	598	735	668	620
4000	694	804	697	768	779	868	812	644
5000	656	702	704	810	889	855	885	780
6000	767	760	810	955	980	1090	1068	1010
8000	986	977	1041	1225	1260	1400	1373	1298

## Regulating Capacities – 2" Size

350	280	290	230	400	250	280	225	-
689	570	700	485	620	535	495	540	350
1000	790	970	790	810	580	740	755	510
1500	820	994	820	835	640	760	775	680
2000	852	1002	833	865	645	891	749	723
3000	1123	1252	1136	826	1084	1330	1214	1123
4000	1394	1614	1394	1536	1549	1730	1614	1278
5000	1446	1549	1549	1769	1975	1910	1988	1743
6000	1687	1678	1807	2117	2169	2427	2375	2272
8000	1928	1916	2064	2416	2476	2772	2716	2596

## Material Specifications

A summary of the material specification for the J125 is given for reference. All material has been selected to provide maximum durability and reliability in service.

Components	Specification
Regulator Body	Nodular Iron BS 2789 420/12
Regulator Valve Disc and "O" rings, USSA Diaphragm	Nitrile Synthetic Rubber (Buna)
USSA Valve Disc and "O" rings	Nitrile Synthetic Rubber (DIN 3535 Part 3)
Regulator Valve, Valve Seat and USSA Valve	Aluminium Alloy BS4300/5 or BS1474
Regulator Case and Cover, Relief Valve, Spring Holder, Top Cap, Adaptor Plate, USSA Body and Cover	Aluminium Alloy BS1490
Regulator Case	Aluminium Alloy ANSI A380/A383
Regulator and USSA Valve Spindle	Stainless Steel BS970
Regulator Diaphragm	Reinforced Synthetic Rubber
USSA Internals	Acetal Resin
Lever Arm, Regulator Diaphragm Plate, Vent Valve Plates, Clamping Plate and Spring Guide	Mild Steel, Zinc Plated and Passivated
Springs	Carbon Steel, Zinc Plated and Passivated
Relief Valve Adjusting Nut	Brass BS2874

## Quality:

Elster Jeavons is committed to a programme of continuous quality enhancement. All equipment designed and manufactured by the Elster-Instromet group benefits from the group's quality assurance standards which are approved to EN ISO 9001:2008.