



Solenoid Valves

CONTROL

LHD Series 3-way miniature solenoid valves used to flow air, gas and mild liquids **A** 1-26

LFA Series 2 and 3-way general purpose ported solenoid valves used to flow air, gas and mild liquids **B** 1-14

DISPENSING

VHS Series high speed 2-way valves for micro-dispensing **C** 1-20

INK Series high speed ink jet printing valves **D** 1-6

ISOLATION

LFV Series 2-way chemically inert valves for aggressive fluids in scientific/analytical instruments and IVD applications **E** 1-18

LFR Series 3-way chemically inert valves for aggressive fluids in scientific/analytical instruments and IVD applications **F** 1-16

LFN Series 2-way valves for applications where space and weight are a premium **G** 1-8

LFY Series 2-way and 3-way, chemically inert valves for use when a “clean flow path” is needed. Low internal volume with zero dead volume. **H** 1-12

Pumps

FIXED VOLUME

LPL Series solenoid operated fixed volume pumps **I** 1-10

VARIABLE VOLUME

LPV Series stepper motor-driven variable volume pumps **J** 1-18

Manifolds, Tubing and Accessories

Manifold..... custom manifold capabilities Technology	K	1-6
MINSTAC miniature inert system of tubing and components	L	1-56
Nozzles direct dispense and atomizing	M	1-10

Special Products

IEP Series 2-way axial flow valves for high pressure/temperature applications	N	1-6
120 Series 2-way inline ultra-miniature latching solenoid valves for air piloting applications	O	1-2
Visco Mixers ... Static mixers for HPLC and other high pressure applications	P	1-4
OV'R Driver An electric driver used to enhance response time or reduce power consumption	Q	1-4
LSP Series 2-way, normally closed, high flow solenoid valves for applications requiring a particle tolerant flow path	R	1-4

Engineering Information	S	1-64
-------------------------	----------	------

General Information

Policies, Proprietary Rights, Patents, Trademarks, Copyrights, Warranty, Sales Offices	T	1-9
---	----------	-----

LHD Series

A



Lee's High Density Interface (LHD Series) Solenoid Valves are designed for applications where space is limited. Featuring small size and light weight without sacrificing performance and reliability, the valves are available in three different styles: plug-in, face mount, and ported. Extended performance versions (Latching, Quiet Operation, Semi-Inert and Lo-Lohm) are also available.

These valves are generally used in medical and scientific instrumentation or control applications such as oxygen delivery systems, gas analysis equipment, patient monitors, air calibration devices, ventilators/respirators, gas chromatography and other flow switching devices. Each valve is 100% functionally tested for switching voltage, flow capacity and leakage. The rugged materials used help ensure consistent long-term performance. The valves will typically operate up to 250 million cycles on air, depending on the seal material and application parameters.



Latching Design

The Latching design is optimized for applications that demand ultra-low power and low heat making it ideal for portable, battery powered instruments. The valves require only momentary (10 ms minimum) pulses of current to switch state resulting in 5.5 millijoule per switch. The polarity of the voltage on the terminal pins controls the switched position.

Quiet Operation Design

The Quiet Operation design uses “whisper technology” to achieve patient comfort. A typical solenoid valve has an inherent clicking sound when energized, which is caused by the metal-to-metal contact of the moving armature and stationary core. With “whisper technology” however, actuation noise is significantly reduced, providing a sound level measurement of less than 37 dBA when measured at a distance of 24 inches and a valve cycle frequency of 10 Hz.

Semi-Inert Design

The Semi-Inert design can handle moderately aggressive gases and liquids in a wide range of fluid handling applications. Featuring a superior perfluoro (FFKM) elastomer seal, this design is also compatible with saline.

Lo-Lohm Design

The Lo-Lohm design offers more flow capacity across an extended pressure range without sacrificing size and weight.

**Projected Battery Life
for Latching Designs**

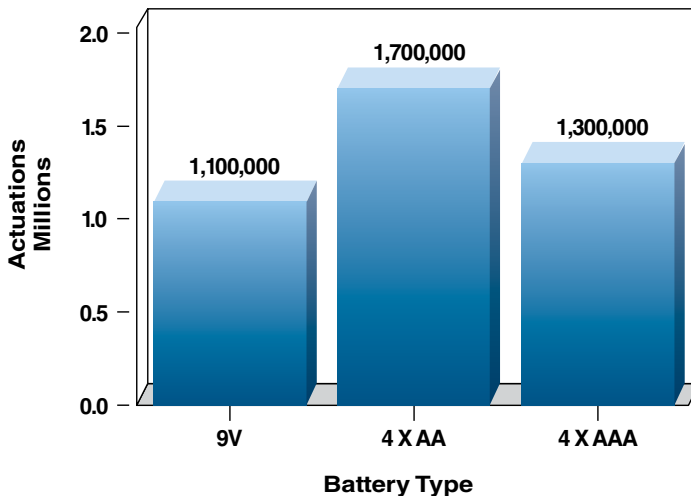

The Lee Company offers several standard manifolds as valuable aids to the designer during development and initial prototyping.

A

Plug-In Style

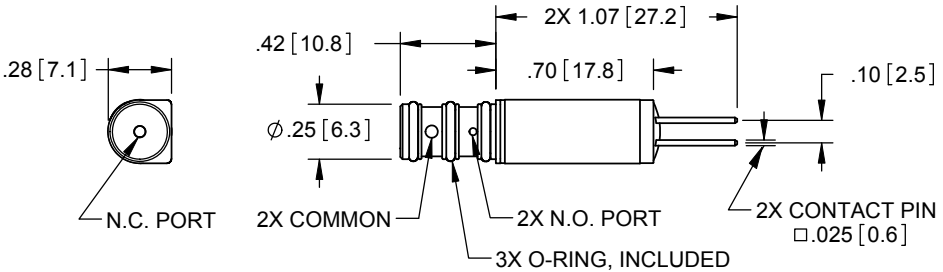

Unless otherwise specified, dimensions are in inches [mm].

PART NUMBER ¹	MODEL	OPERATING PRESSURE	POWER CONSUMPTION ⁵ (mW)	
LHDA__11111H	3-Way	Vac-15 psig (0-15 psid)	550	
LHDA__11211H	3-Way	Vac-15 psig (0-15 psid)	550	
LHDA__11311H	3-Way	Vac-15 psig (0-15 psid)	550	
LHDA__11411H	3-Way	Vac-15 psig (0-15 psid)	550	

NOTES: (1) Solenoid valves are available in 5, 12 and 24 vdc configurations.

LHDA__11111H

↑
Coil Voltage: 05 = 5 vdc / 12 = 12 vdc / 24 = 24 vdc

Plug-In Style

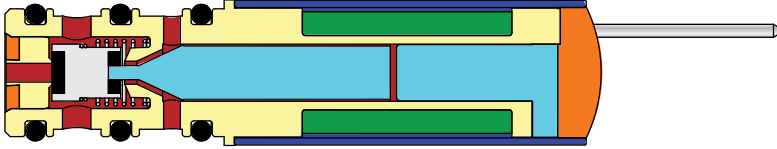

- Coil
- Housing
- Shield
- Armature/
Plunger Stop
- Seal
- Flow Path
- Plunger Head
Assembly
- Epoxy

LOHM RATE ²	WETTED MATERIALS ³				
	SEAL MATERIAL	HOUSING	PLUNGER HEAD	ARMATURE/ PLUNGER STOP	SPRING
1100	SI (Seal), FKM (O-ring)	PBT	PPS	430 SS	302 SS
1100	FKM	PBT	PPA	430 SS	302 SS
1100	SI (Seal), FKM (O-ring)	PBT	PPS	FeCr Alloy ⁴	316 SS
1100	FKM	PBT	PPA	FeCr Alloy ⁴	316 SS

(2) Refer to Engineering Section, [page S3](#) for a full description of the Lohm Laws.

(3) Refer to Engineering Section, [pages S61-62](#) for material information and abbreviations.
Epoxy is used in the valve assembly and therefore considered a wetted material.

(4) Wetted materials are optimized for saline compatibility.

(5) See [page A20](#) for complete electrical characteristics.

A

Plug-In Style, Extended Performance

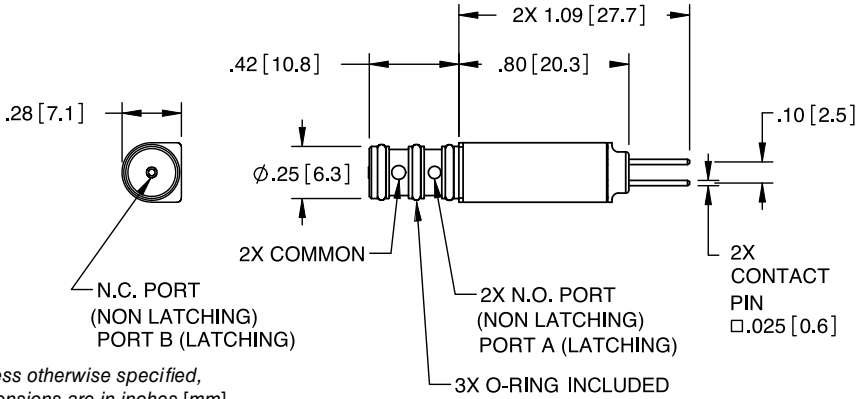

	PART NUMBER ¹	MODEL	OPERATING PRESSURE	POWER CONSUMPTION ⁵	
Semi-Inert Design	LHDA__11515H	3-Way	Vac-45 psig (0-15 psid)	850 mW	
Quiet Operation Design	LHDA__61215H ⁶	3-Way	Vac-45 psig (0-15 psid)	750 mW	
Lo-Lohm Design	LHDA__60245D ⁷	2-Way NC (Common Inlet)	Vac-50 psig (0-50 psid)	550 mW (Hold Power)	
	LHDA__60365D ⁷	2-Way NO (NO Inlet)	Vac-50 psig (0-50 psid)	550 mW (Hold Power)	
Latching Design	LHLA__11111H ⁸	3-Way	Vac-45 psig (0-15 psid)	5.5 mJ per Switch	
	LHLA__11211H ⁸	3-Way	Vac-45 psig (0-15 psid)	5.5 mJ per Switch	
	LHLA__11311H ⁸	3-Way	Vac-45 psig (0-15 psid)	5.5 mJ per Switch	
	LHLA__11411H ⁸	3-Way	Vac-45 psig (0-15 psid)	5.5 mJ per Switch	

NOTES: (1) Solenoid valves are available in 5, 12 and 24 vdc configurations.

LHDA__11515H

Coil Voltage: 05 = 5 vdc / 12 = 12 vdc / 24 = 24 vdc

(2) Refer to Engineering Section, [page S3](#) for a full description of the Lohm Laws.

(3) Refer to Engineering Section, [pages S61-62](#) for material information and abbreviations. Epoxy is used in the valve assembly and therefore considered a wetted material.

Plug-In Style, Extended Performance

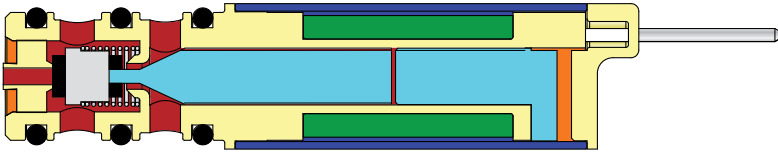

LOHM RATE ²	WETTED MATERIALS ³				
	SEAL MATERIAL	HOUSING	PLUNGER HEAD	ARMATURE/PLUNGER STOP	SPRING
1500	FFKM	PBT	PPA	FeCr Alloy ⁴	316 SS
1500	FKM	PBT	PPA	430 SS	316 SS
450	FKM	PBT	PPA	430 SS	316 SS
650	FKM	PBT	PPA	430 SS	316 SS
1100	SI (Seal), FKM (O-ring)	PBT	PPS	430 SS	316 SS
1100	FKM	PBT	PPA	430 SS	316 SS
1100	SI (Seal), FKM (O-ring)	PBT	PPS	FeCr Alloy ⁴	316 SS
1100	FKM	PBT	PPA	FeCr Alloy ⁴	316 SS

(4) Wetted materials are optimized for saline compatibility.

(5) See [page A20](#) for complete electrical characteristics.

(6) This design is intended for air and gas only. It contains a hydrocarbon synthetic oil in the wetted path to reduce actuation noise.

(7) Spike and hold drive required. See [page A24](#) for drive characteristics.
Only available in 5 and 12 vdc hold models.

(8) See [page A23](#) for additional information on latching valves.

Standard Plug-In Style Manifolds

PART NUMBER	DESCRIPTION	DIMENSION "A"	DIMENSION "B"
LFMX0522450B	Manifold, HDI, Plug-In, 1x, Individual Ports	0.75" (19.1 mm)	0.50" (12.7 mm)
LFMX0510413B	Manifold, HDI, Plug-In, 3x, Individual Ports	1.35" (34.3 mm)	1.10" (27.9 mm)
LFMX0510418B	Manifold, HDI, Plug-In, 8x, Individual Ports	2.85" (72.4 mm)	2.60" (66.0 mm)
LFMX0510423B	Manifold, HDI, Plug-In, 3x, Common Header, Individual NC & NO Ports	1.50" (38.1 mm)	1.25" (31.8 mm)
LFMX0510428B	Manifold, HDI, Plug-In, 8x, Common Header, Individual NC & NO Ports	3.00" (76.2 mm)	2.75" (69.9 mm)
LFMX0510433B	Manifold, HDI, Plug-In, 3x, NC & NO Header, Individual Common Ports	1.50" (38.1 mm)	1.25" (31.8 mm)
LFMX0510438B	Manifold, HDI, Plug-In, 8x, NC & NO Header, Individual Common Ports	3.00" (76.2 mm)	2.75" (69.9 mm)

NOTES: (1) Part Numbers are for the manifold only. Secondary retention bracket included. Valves sold separately.

(2) Manifolds are anodized aluminum. A 1x acrylic manifold with individual ports is also available, Part Number LFMX0503800A. Contact The Lee Company for additional information

Refer to Manifold Technology ([Section K](#)) for custom design capabilities.



Standard Plug-In Style Manifolds

Individual Ports

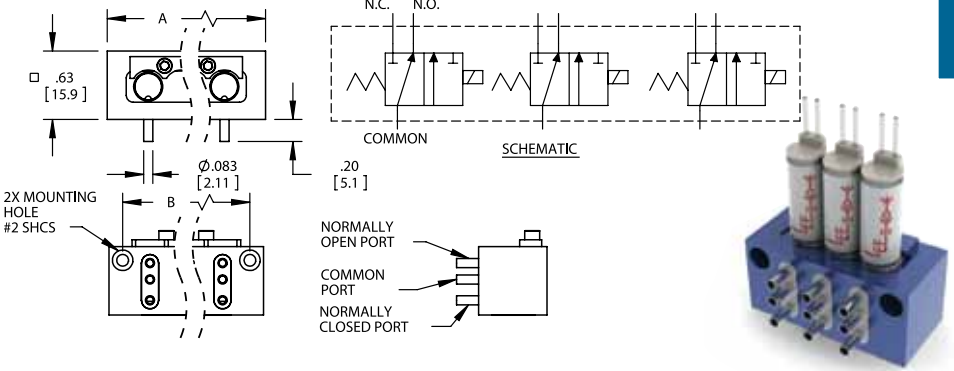

Normally Open and Normally Closed Header, Individual Common Ports

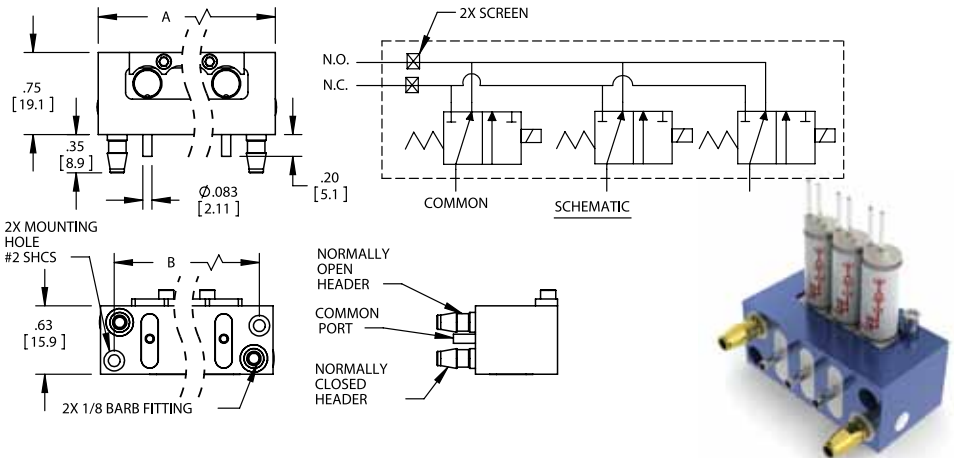

Common Header, Individual Normally Open and Normally Closed Ports

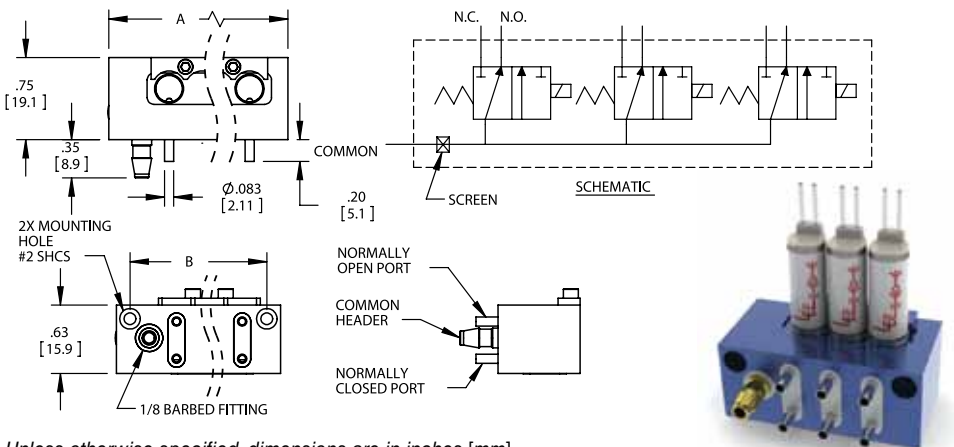

Unless otherwise specified, dimensions are in inches [mm].

A

Face Mount Style

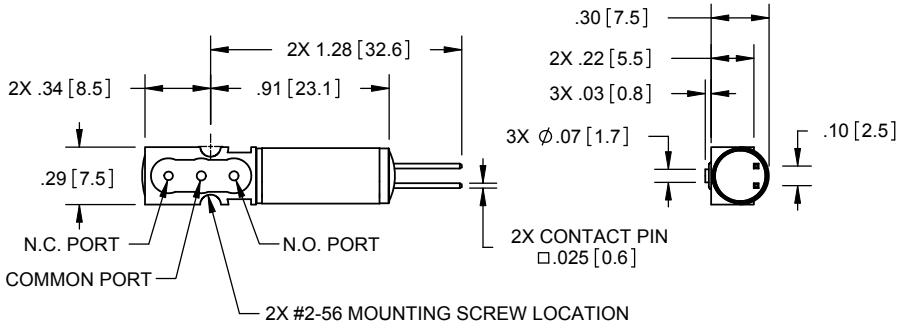

Unless otherwise specified, dimensions are in inches [mm].

PART NUMBER ¹	MODEL	OPERATING PRESSURE	POWER CONSUMPTION ⁵ (mW)	
LHDA__21111H	3-Way	Vac-45 psig (0-15 psid)	550	
LHDA__21211H	3-Way	Vac-45 psig (0-15 psid)	550	
LHDA__21311H	3-Way	Vac-45 psig (0-15 psid)	550	
LHDA__21411H	3-Way	Vac-45 psig (0-15 psid)	550	
LHDA0523112H	3-Way	Vac-45 psig (0-30 psid)	750	
LHDA0523212H	3-Way	Vac-45 psig (0-30 psid)	750	
LHDA0523312H	3-Way	Vac-45 psig (0-30 psid)	750	
LHDA0523412H	3-Way	Vac-45 psig (0-30 psid)	750	
LHDA__23111H ⁶	3-Way	Vac-45 psig (0-30 psid)	750	
LHDA__23211H ⁶	3-Way	Vac-45 psig (0-30 psid)	750	
LHDA__23311H ⁶	3-Way	Vac-45 psig (0-30 psid)	750	
LHDA__23411H ⁶	3-Way	Vac-45 psig (0-30 psid)	750	

NOTES: (1) Solenoid valves are available in 5, 12 and 24 vdc configurations.

LHDA__21111H



Coil Voltage: 05 = 5 vdc / 12 = 12 vdc / 24 = 24 vdc

Face Mount Style

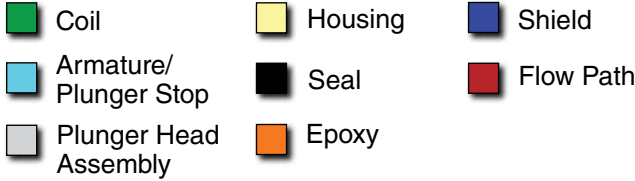
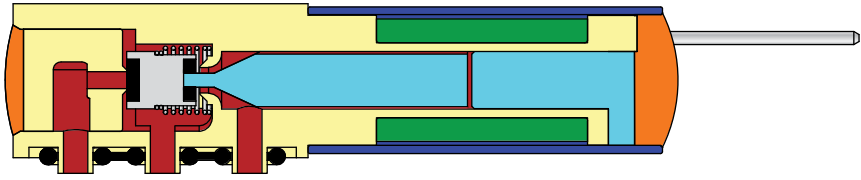

	LOHM RATE ²	WETTED MATERIALS ³				
		SEAL MATERIAL	HOUSING	PLUNGER HEAD	ARMATURE/ PLUNGER STOP	SPRING
	1100	SI	PBT	PPS	430 SS	302 SS
	1100	FKM	PBT	PPA	430 SS	302 SS
	1100	SI	PBT	PPS	FeCr Alloy ⁴	316 SS
	1100	FKM	PBT	PPA	FeCr Alloy ⁴	316 SS
	1200	SI	PBT	PPS	430 SS	302 SS
	1200	FKM	PBT	PPA	430 SS	302 SS
	1200	SI	PBT	PPS	FeCr Alloy ⁴	316 SS
	1200	FKM	PBT	PPA	FeCr Alloy ⁴	316 SS
	1100	SI	PBT	PPS	430 SS	302 SS
	1100	FKM	PBT	PPA	430 SS	302 SS
	1100	SI	PBT	PPS	FeCr Alloy ⁴	316 SS
	1100	FKM	PBT	PPA	FeCr Alloy ⁴	316 SS

(2) Refer to Engineering Section, [page S3](#) for a full description of the Lohm Laws.

(3) Refer to Engineering Section, [pages S61-62](#) for material information and abbreviations.
Epoxy is used in the valve assembly and therefore considered a wetted material.

(4) Wetted materials are optimized for saline compatibility.

(5) See [page A20](#) for complete electrical characteristics.

(6) Available in 12 and 24 vdc configurations only.

A

Face Mount Style, Extended Performance

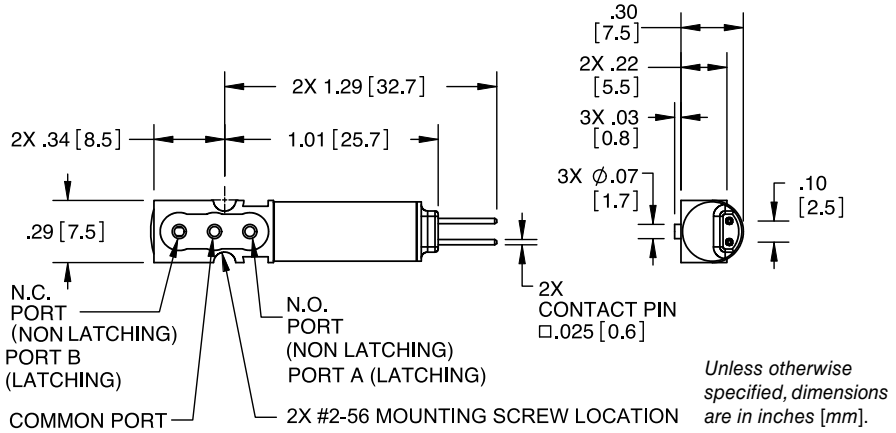

	PART NUMBER ¹	MODEL	OPERATING PRESSURE	POWER CONSUMPTION ⁵	
Semi-Inert Design	LHDA__21515H	3-Way	Vac-45 psig (0-15 psid)	850 mW	
Quiet Operation Design	LHDA__71215H ⁶	3-Way	Vac-45 psig (0-15 psid)	750 mW	
Lo-Lohm Design	LHDA__70290D ⁷	2-Way NC (Common Inlet)	Vac-50 psig (0-50 psid)	550 mW (Hold Power)	
Latching Design	LHLA__21111H ⁸	3-Way	Vac-45 psig (0-15 psid)	5.5 mJ per Switch	
	LHLA__21211H ⁸	3-Way	Vac-45 psig (0-15 psid)	5.5 mJ per Switch	
	LHLA__21311H ⁸	3-Way	Vac-45 psig (0-15 psid)	5.5 mJ per Switch	
	LHLA__21411H ⁸	3-Way	Vac-45 psig (0-15 psid)	5.5 mJ per Switch	

NOTES: (1) Solenoid valves are available in 5, 12 and 24 vdc configurations.

LHDA__21515H



Coil Voltage: 05 = 5 vdc / 12 = 12 vdc / 24 = 24 vdc

(2) Refer to Engineering Section, page S3 for a full description of the Lohm Laws.

(3) Refer to Engineering Section, pages S61-62 for material information and abbreviations. Epoxy is used in the valve assembly and therefore considered a wetted material.

Face Mount Style, Extended Performance

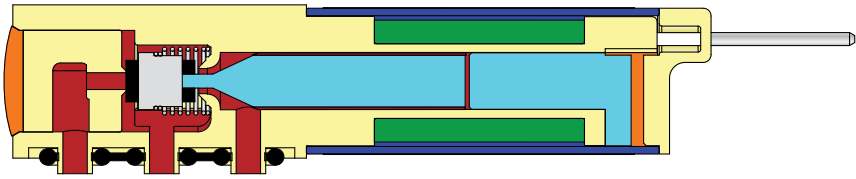

LOHM RATE ²	WETTED MATERIALS ³				
	SEAL MATERIAL	HOUSING	PLUNGER HEAD	ARMATURE/ PLUNGER STOP	SPRING
1500	FFKM	PBT	PPA	FeCr Alloy ⁴	316 SS
1500	FKM	PBT	PPA	430 SS	316 SS
900	FKM	PBT	PPA	430 SS	316 SS
1100	SI	PBT	PPS	430 SS	316 SS
1100	FKM	PBT	PPA	430 SS	316 SS
1100	SI	PBT	PPS	FeCr Alloy ⁴	316 SS
1100	FKM	PBT	PPA	FeCr Alloy ⁴	316 SS

(4) Wetted materials are optimized for saline compatibility.

(5) See [page A20](#) for complete electrical characteristics.

(6) This design is intended for air and gas only. It contains a hydrocarbon synthetic oil in the wetted path to reduce actuation noise.

(7) Spike and hold drive required. See [page A24](#) for drive characteristics.
Only available in 5 and 12 vdc hold models.

(8) See [page A23](#) for additional information on latching valves.

Standard Face Mount Style Manifolds

PART NUMBER	DESCRIPTION	DIMENSION "A"	DIMENSION "B"
LFMX0507200A	Manifold, HDI, Face Mount, 1x, Individual Ports	0.44" (11.2 mm)	0.30" (7.6 mm)
LFMX0510513B	Manifold, HDI, Face Mount, 3x, Individual Ports	1.35" (34.3 mm)	1.10" (27.9 mm)
LFMX0510518B	Manifold, HDI, Face Mount, 8x, Individual Ports	2.86" (72.6 mm)	2.59" (65.8 mm)
LFMX0510523B	Manifold, HDI, Face Mount, 3x, Common Header, Individual NC & NO Ports	1.51" (38.4 mm)	1.29" (32.8 mm)
LFMX0510528B	Manifold, HDI, Face Mount, 8x, Common Header, Individual NC & NO Ports	3.02" (76.7 mm)	2.79" (70.9 mm)
LFMX0510533B	Manifold, HDI, Face Mount, 3x, NC & NO Header, Individual Common Ports	1.55" (39.4 mm)	1.28" (32.5 mm)
LFMX0510538B	Manifold, HDI, Face Mount, 8x, NC & NO Header, Individual Common Ports	3.05" (77.5 mm)	2.78" (70.6 mm)

NOTES: (1) Part Numbers are for the manifold only. Valves and mounting hardware sold separately. See [page A25](#) for mounting hardware part numbers
 (2) Manifolds are anodized aluminum.

Refer to Manifold Technology ([Section K](#)) for custom design capabilities.



A

Standard Face Mount Style Manifolds

Individual Ports

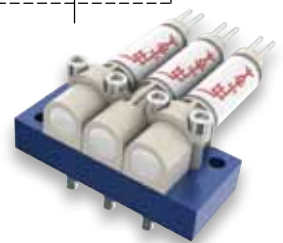
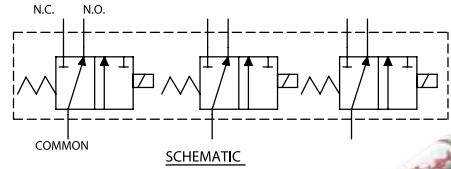
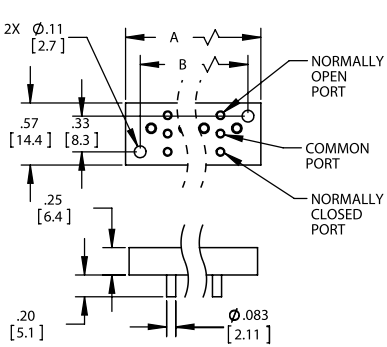

Normally Open and Normally Closed Header, Individual Common Ports

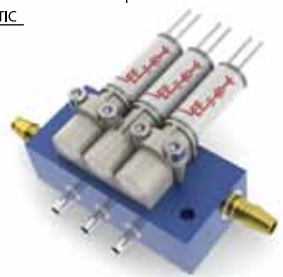
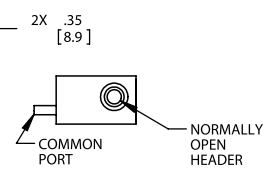
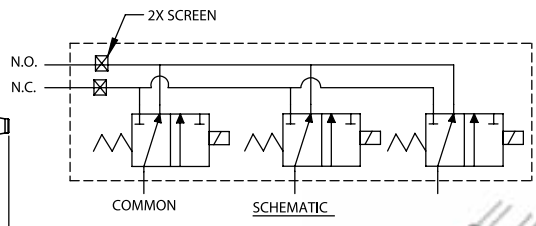
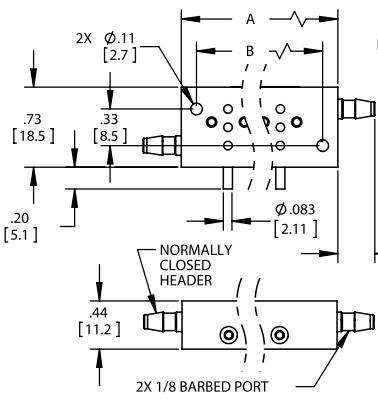

Common Header, Individual Normally Open and Normally Closed Ports

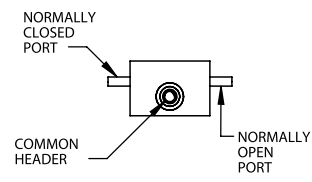
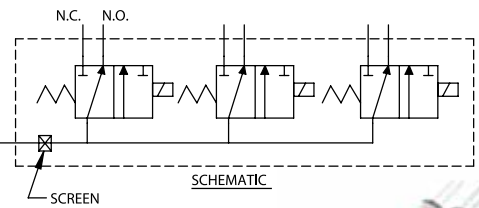
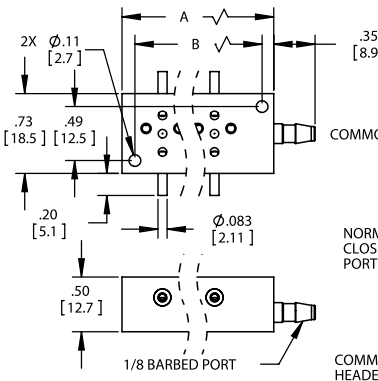

Unless otherwise specified, dimensions are in inches [mm].

Soft Tube Ported Style

A

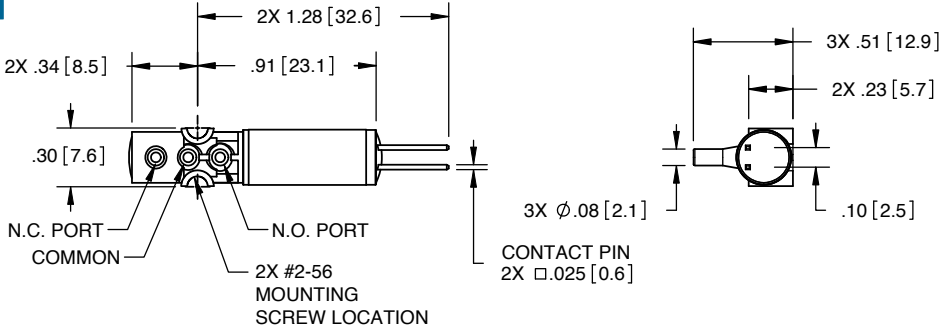

Unless otherwise specified, dimensions are in inches [mm].

PART NUMBER ¹	MODEL	OPERATING PRESSURE	POWER CONSUMPTION ⁵ (mW)	
LHDA__31115H	3-Way	Vac-45 psig (0-15 psid)	550	
LHDA__31215H	3-Way	Vac-45 psig (0-15 psid)	550	
LHDA__31315H	3-Way	Vac-45 psig (0-15 psid)	550	
LHDA__31415H	3-Way	Vac-45 psig (0-15 psid)	550	
LHDA__33115H	3-Way	Vac-45 psig (0-30 psid)	750	
LHDA__33215H	3-Way	Vac-45 psig (0-30 psid)	750	
LHDA__33315H	3-Way	Vac-45 psig (0-30 psid)	750	
LHDA__33415H	3-Way	Vac-45 psig (0-30 psid)	750	

Soft Tube Ported Valve is designed for use with soft (flexible) 1/16" ID tubing.

NOTES: (1) Solenoid valves are available in 5, 12 and 24 vdc configurations.

LHDA__31115H



Coil Voltage: 05 = 5 vdc / 12 = 12 vdc / 24 = 24 vdc

Soft Tube Ported Style

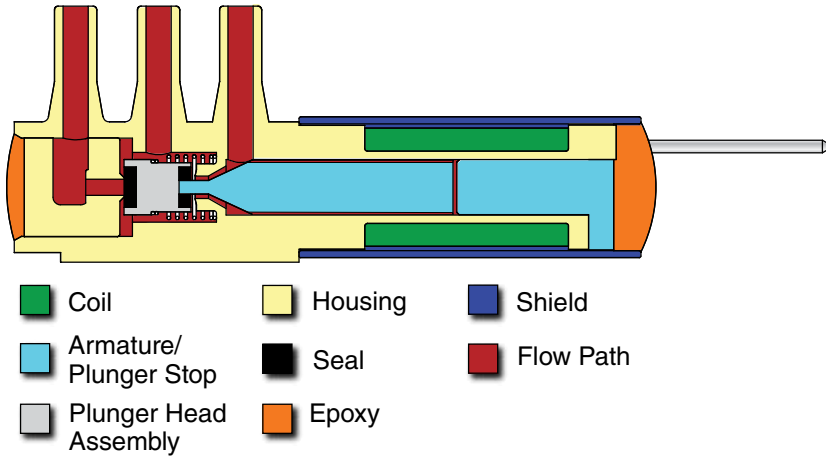

	LOHM RATE ²	WETTED MATERIALS ³				
		SEAL MATERIAL	HOUSING	PLUNGER HEAD	ARMATURE/ PLUNGER STOP	SPRING
	1500	SI	PBT	PPS	430 SS	302 SS
	1500	FKM	PBT	PPA	430 SS	302 SS
	1500	SI	PBT	PPS	FeCr Alloy ⁴	316 SS
	1500	FKM	PBT	PPA	FeCr Alloy ⁴	316 SS
	1500	SI	PBT	PPS	430 SS	302 SS
	1500	FKM	PBT	PPA	430 SS	302 SS
	1500	SI	PBT	PPS	FeCr Alloy ⁴	316 SS
	1500	FKM	PBT	PPA	FeCr Alloy ⁴	316 SS

(2) Refer to Engineering Section, [page S3](#) for a full description of the Lohm Laws.

(3) Refer to Engineering Section, [pages S61-62](#) for material information and abbreviations.
Epoxy is used in the valve assembly and therefore considered a wetted material.

(4) Wetted materials are optimized for saline compatibility.

(5) See [page A20](#) for complete electrical characteristics.

A

Soft Tube Ported Style, Extended Performance

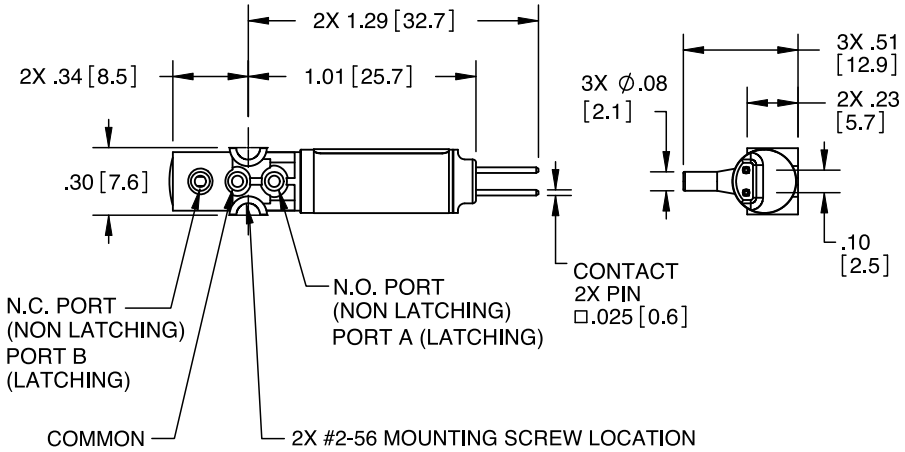

Unless otherwise specified, dimensions are in inches [mm].

	PART NUMBER ¹	MODEL	OPERATING PRESSURE	POWER CONSUMPTION ⁵	
Semi-Inert Design	LHDA__31515H	3-Way	Vac-45 psig (0-15 psid)	850 mW	
Quiet Operation Design	LHDA__81215H ⁶	3-Way	Vac-45 psig (0-15 psid)	750 mW	
Latching Design	LHLA__31111H ⁷	3-Way	Vac-45 psig (0-15 psid)	5.5 mJ per Switch	
	LHLA__31211H ⁷	3-Way	Vac-45 psig (0-15 psid)	5.5 mJ per Switch	
	LHLA__31311H ⁷	3-Way	Vac-45 psig (0-15 psid)	5.5 mJ per Switch	
	LHLA__31411H ⁷	3-Way	Vac-45 psig (0-15 psid)	5.5 mJ per Switch	

Soft Tube Ported Valve is designed for use with soft (flexible) 1/16" ID tubing.

NOTES: (1) Solenoid valves are available in 5, 12 and 24 vdc configurations.

LHDA__31515H



Coil Voltage: 05 = 5 vdc / 12 = 12 vdc / 24 = 24 vdc

(2) Refer to Engineering Section, [page S3](#) for a full description of the Lohm Laws.

Soft Tube Ported Style, Extended Performance

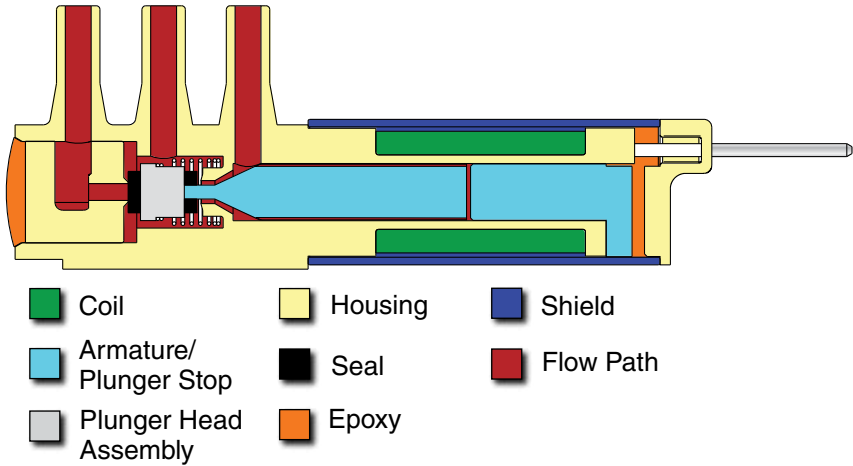

	LOHM RATE ²	WETTED MATERIALS ³				
		SEAL MATERIAL	HOUSING	PLUNGER HEAD	ARMATURE/PLUNGER STOP	SPRING
	1500	FFKM	PBT	PPA	FeCr Alloy ⁴	316 SS
	1500	FKM	PBT	PPA	430 SS	316 SS
	1100	SI	PBT	PPS	430 SS	316 SS
	1100	FKM	PBT	PPA	430 SS	316 SS
	1100	SI	PBT	PPS	FeCr Alloy ⁴	316 SS
	1100	FKM	PBT	PPA	FeCr Alloy ⁴	316 SS

(3) Refer to Engineering Section, [pages S61-62](#) for material information and abbreviations. Epoxy is used in the valve assembly and therefore considered a wetted material.

(4) Wetted materials are optimized for saline compatibility.

(5) See [page A20](#) for complete electrical characteristics.

(6) This design is intended for air and gas only. It contains a hydrocarbon synthetic oil in the wetted path to reduce actuation noise.

(7) See [page A23](#) for additional information on latching valves.

A

GENERAL SPECIFICATIONS

The following specifications apply to all LHD Series valves, unless otherwise noted.

Leakage

Maximum of 50 μL /minute of air at 70°F with 5 psig applied to the common port.

Internal Volume

Plug-In:	40 μL
Face Mount:	72 μL
Soft Tube Ported:	77 μL

Weight

The valves weigh only 4 grams.

Life Expectancy

The valves will typically operate up to 250 million cycles on air, depending on the seal material and application parameters.

Operating Pressure

The valves will operate within the specified pressure range when supplied with the rated voltage $\pm 5\%$. The normally closed port seal is spring loaded, so the pressure applied to this port should not exceed the pressure on the common port or the normally open port unless otherwise indicated.

- Valve Proof Pressure: 2X Normal Rated Pressure
- Valve Burst Pressure: 3X Normal Rated Pressure

Operating Temperature

- Ambient operating temperature range is 40°F to 120°F (4°C to 49°C).

MEAN POWER (mW)	INTERNAL SELF-HEATED COIL TEMPERATURE AT 100% DUTY, 72°F AMBIENT ENVIRONMENT
550	165°F (74°C)
750	185°F (85°C)
850	195°F (90°C)

- Increasing the operating temperature tends to limit coil performance. The valve duty cycle and energized time must be evaluated for conformance with the maximum recommended operating and coil temperatures.
- Maximum internal coil temperature not to exceed 250°F (121°C).

Storage Conditions (Recommended)

- Temperature: -40°F to 175°F (-40°C to 80°C)
- Relative humidity: 85% max., non-condensing

Coil Type (DC)

- LHD Series: Electrical connection can be made without regard to polarity.
- LHL Series: Polarity must be taken into consideration to switch the valve from state to state. See [page A23](#).

Response Time

- Typical response times in milliseconds are as follows:

FLUID	MEAN POWER (mW)	@ RATED VOLTAGE (10 psig)	
		ENERGIZE	DE-ENERGIZE
Air	550	3	4
	750	3	4
	850	3	4
Water	550	4	5
	750	4	5
	850	4	5

- Response times can be enhanced with the use of high speed drive circuits. Refer to Engineering Section, [page S38](#).
- The Quiet Operation design will have a slightly slower response time due to the damping operation.
- Response times are dependent upon system conditions, power input, environment, etc.

Port Connections

The tube ports are designed for soft, flexible 1/16" ID tubing.

Mounting Information

Surface mount valves use #2 socket head cap screws. Refer to inspection drawings for torque specification.

Filtration

Filtration of 35 microns or finer is recommended.

Electrical Characteristics

The following chart describes the basic electrical characteristics for the LHD Series valves at room temperature. Refer to Engineering Section, [pages S35-43](#) for special drive circuits.

POWER AT RATED VOLTAGE (mW)	VOLTAGE (vdc)	COIL RESISTANCE (ohms)	INDUCTANCE (mH)
550	5	46	30
550	12	262	155
550	24	1042	665
750	5	33	20
750	12	193	130
750	24	766	460
850	5	30	12
850	12	170	70
850	24	675	340

VALVE MOUNTING DETAILS

(Drawings are not drawn to scale)

Plug-In

(Boss Cutting Tool, Lee Part Number TTTA0000180B)

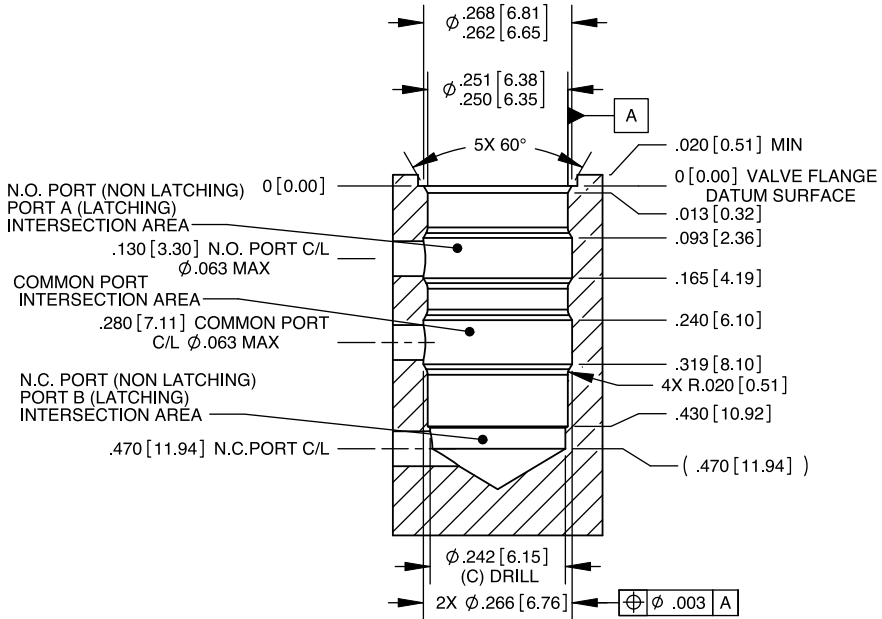

Reference Drawing Number LCFX0300100B for Installation Hole Specification Details

Face Mount

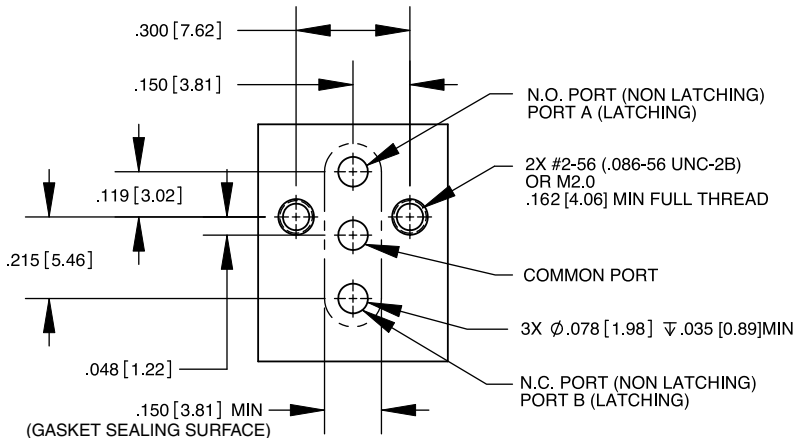

Reference Drawing Number LFIX1001150A for Face Mount Boss Specification Details

Unless otherwise specified, dimensions are in inches [mm].

**Typical Flow Characteristics
(LHD Series Valves)**

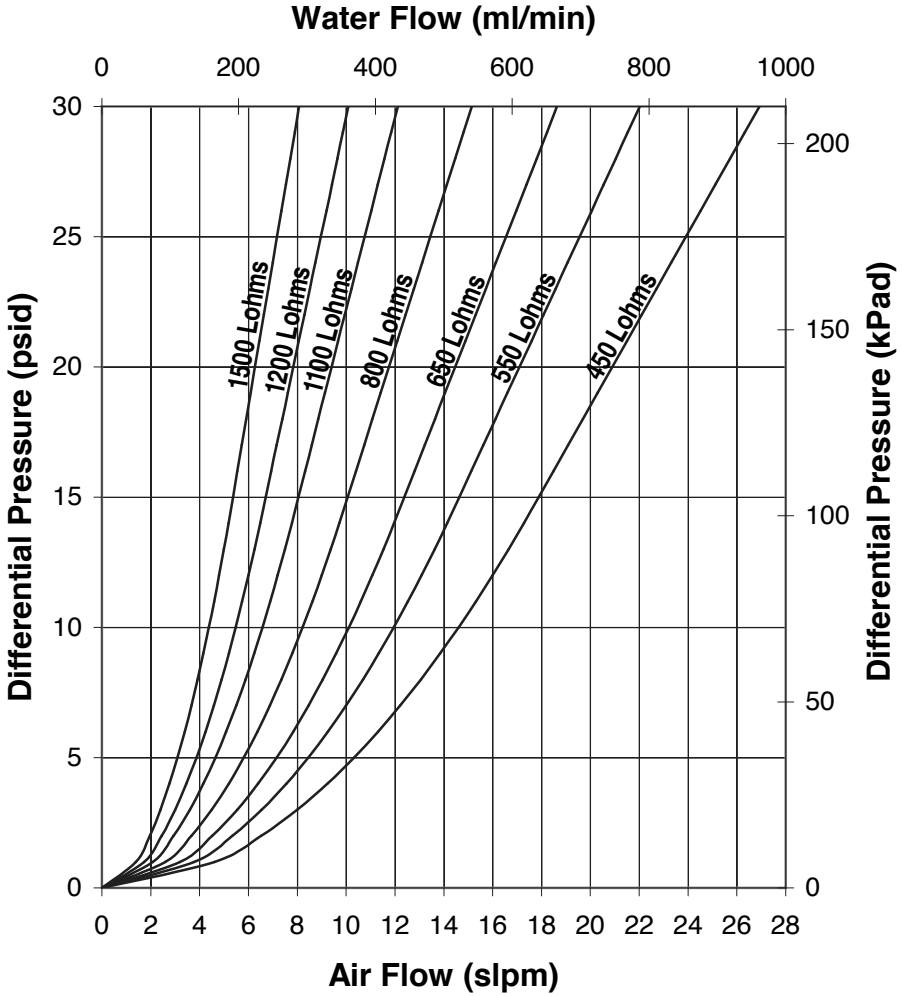

A

Latching Valve (LHL Series) Reference Information

The LHL Series magnetic latching valves are optimized for applications that demand ultra-low power (5.5 mJ per switch) and low heat making the valves ideal for portable, battery powered devices. The flow direction of a latching valve will switch to and remain in the direction indicated when a 10 ms pulse (min) is applied with the voltage and polarity as indicated in the table below. Refer to Engineering Section [pages S41-43](#) for recommended driver circuit schematic. Specific pin terminal designations for each configuration are shown in the drawings below.

VOLTAGE	TERMINAL	VALVE STATE / FLOW DIRECTION
Rated Voltage Return	1	Port A – Common Flow ↔
	2	
Rated Voltage Return	2	Port B – Common Flow ↔
	1	

Pin Terminal Designations

Plug-In Style

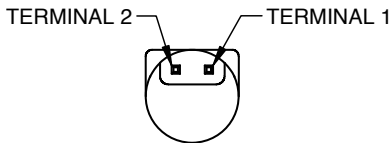

Face Mount Style

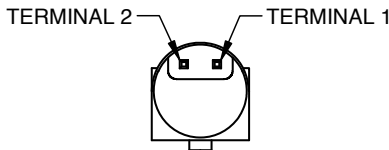

Ported Style

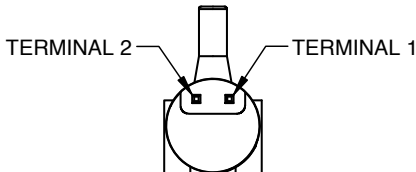

Lo-Lohm Spike and Hold Reference Information

The Lo-Lohm design offers more flow capacity across an extended pressure range without sacrificing size and weight. A spike and hold voltage drive is required to achieve the extended flow performance with differential pressure ranges up to 50 psid. Please refer to the table below for porting specifications as well as spike actuation and hold voltage requirements at 50 psid. Spike voltage requirements for lower differential pressure operating ranges are shown in the graph below.

STYLE	CONFIGURATION	PORTING	PART NUMBER	SPIKE ACTUATION VOLTAGE (10 to 25 ms @ 50 psid) (vdc)	HOLD VOLTAGE (vdc)
Plug-In	2-Way NC	Common Inlet	LHDA0560245D	15	5
			LHDA1260245D	32	12
	2-Way NO	NO Inlet	LHDA0560365D	11	5
			LHDA1260365D	25	12
Face Mount	2-Way NC	Common Inlet	LHDA0570290D	19	5
			LHDA1270290D	45	12

Spike Actuation Voltage vs. Differential Pressure

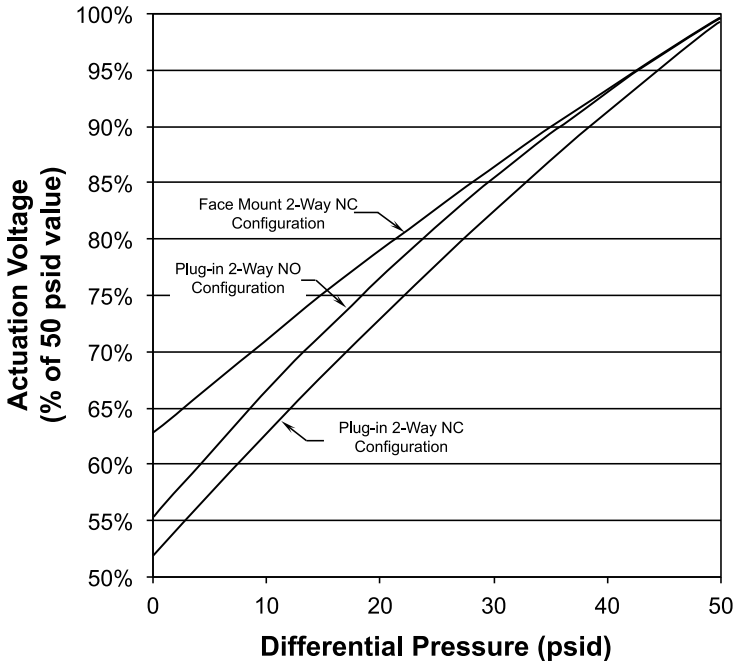

A

General Accessories / Replacement Parts

STYLE	PART NUMBER	DESCRIPTION
Plug-In	LHWX0218030A	Replacement O-ring (FKM)
	LHDX0526050A	Boss Plug (POM with FKM O-rings)
	TTTA0000180B	Boss Cutting Tool
Face Mount	LHWX0218000A	Gasket (SI)
	LHWX0218010A	Gasket (FKM)
	LLWX0218170A	Gasket (FFKM)
	LHDX0307130A	Mounting Screw Support-2x, PBT
	LHDX0307140A	Mounting Screw Support-1x, PBT
	LHWX0503100A	Screw, Socket Head Cap, 0.086" (#2)-56 x 0.375" SS
	LHWX0213420A ¹	Screw, Socket Head Cap, 0.086" (#2)-56 x 0.438 (7/16) SS
Ported	LHWX0320090A	Port Plug
	LHWX0503100A	Screw, Socket Head Cap, 0.086" (#2)-56 x 0.375" SS
Universal (Plug-In, Face Mount, & Ported)	LTTA0300000A	Installation/Extraction Tool
	LHWX0605450A	Electrical Lead-Wire Connector

NOTES: (1) Required for use with mounting screw support (recommended).

NOTES

A

LFA Series

B



The Lee Interface Fluidic (LFA Series) Solenoid Valves offer small size and light weight, without sacrificing performance. Designed for applications where space is limited, these valves are generally used for medical and scientific applications flowing air or gas, such as blood chemistry instruments, ventilators/respirators, gas analysis equipment, blood pressure monitors and various other flow switching devices.

LFA Series valves are available as a 2-way (normally closed) or 3-way soft tube ported design with two electrical connection options; printed circuit board mount or lead-wires. The following general performance characteristics are offered in this product platform:

- Operating Pressures up to 30 psig
- Power Consumption as Low as 280 mW
- Response Times as Fast as 1.5 ms
- Low Internal Volume
- Standard Voltages Available: 5, 9, 12, 24 vdc
- Several Lohm Rates: 1000 to 1800

Each valve is 100% functionally tested for switching voltage, flow capacity, and leakage. Rugged materials are used to ensure consistent long-term performance. The valves will typically operate up to 200 million cycles on air, depending on the seal material and application parameters.

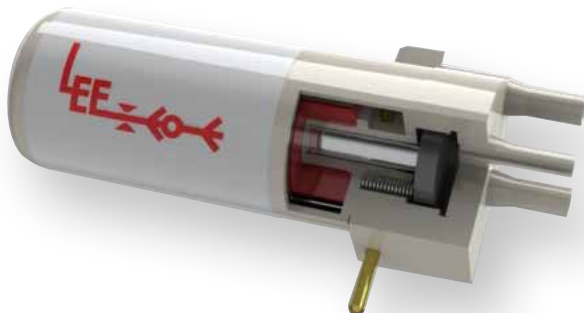

2-Way N.C. Ported Style with Lead Wires

B

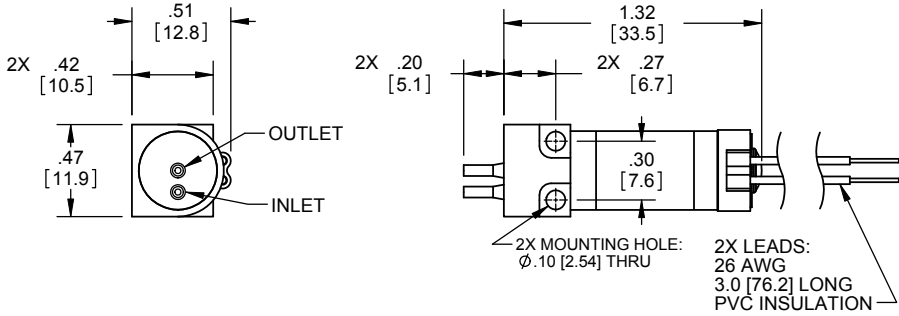

Unless otherwise specified, dimensions are in inches [mm].

PART NUMBER ¹	PORT OUTER DIAMETER	OPERATING PRESSURE (psig)	POWER CONSUMPTION (mW)	LOHM RATE ²	
LFAA__00218H	.054" (1.37 mm)	0 – 7	280	1800	
LFAA__01518H	.054" (1.37 mm)	0 – 7	280	1800	
LFAA__07018H	.054" (1.37 mm)	0 – 7	280	1800	
LFAA__00210H	.080" (2.03 mm)	0 – 7	280	1000	
LFAA__01510H	.080" (2.03 mm)	0 – 7	280	1000	
LFAA__07010H	.080" (2.03 mm)	0 – 7	280	1000	

NOTES: (1) Most solenoid valves are available in 5, 9, 12 and 24 vdc configurations.

LFAA__00218H

↑
Coil Voltage: 05 = 5 vdc / 09 = 9 vdc
12 = 12 vdc / 24 = 24 vdc

2-Way N.C. Ported Style with Lead Wires

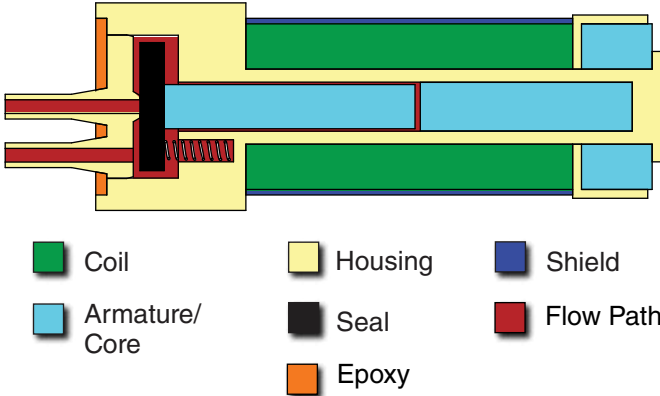

B

	WETTED MATERIALS ³				
	HOUSING	ARMATURE	CORE	SPRING	ELASTOMER
	PBT	430 SS	430 SS	302 SS	CR
	PBT	430 SS	430 SS	302 SS	SI
	PBT	430 SS	430 SS	316 SS	EPDM
	PBT	430 SS	430 SS	302 SS	CR
	PBT	430 SS	430 SS	302 SS	SI
	PBT	430 SS	430 SS	316 SS	EPDM

- (2) Refer to Engineering Section, [page S3](#) for a full description of the Lohm Laws.
- (3) Refer to Engineering Section, [pages S61-62](#) for material information and abbreviations. Epoxy is used in the valve assembly and therefore considered a wetted material.
- (4) See [page B12](#) for complete electrical characteristics.

2-Way N.C. Ported Style with Circuit Board Mounts

B

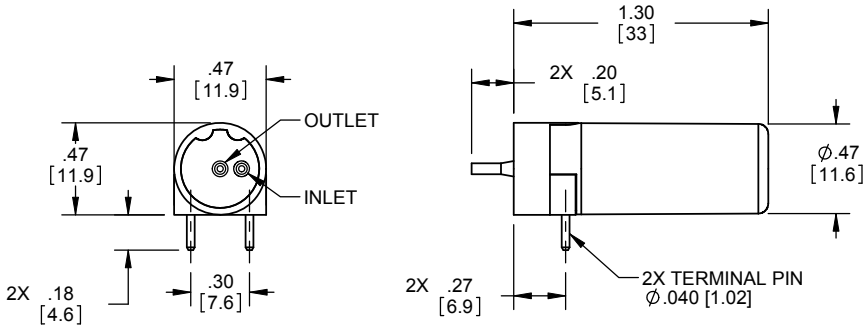

Unless otherwise specified, dimensions are in inches [mm].

PART NUMBER ¹	PORT OUTER DIAMETER	OPERATING PRESSURE (psig)	POWER CONSUMPTION (mW)	LOHM RATE ²	
LFAA__03218H	.054" (1.37 mm)	0 – 7	280	1800	
LFAA__03518H	.054" (1.37 mm)	0 – 7	280	1800	
LFAA__03210H	.080" (2.03 mm)	0 – 7	280	1000	
LFAA__03510H	.080" (2.03 mm)	0 – 7	280	1000	
LFAA__09512H	.080" (2.03 mm)	Vac – 30 (0-10 psid)	780	1200	

NOTES: (1) Most solenoid valves are available in 5, 9, 12 and 24 vdc configurations.

LFAA__03218H



Coil Voltage: 05 = 5 vdc / 09 = 9 vdc
12 = 12 vdc / 24 = 24 vdc

2-Way N.C. Ported Style with Circuit Board Mounts

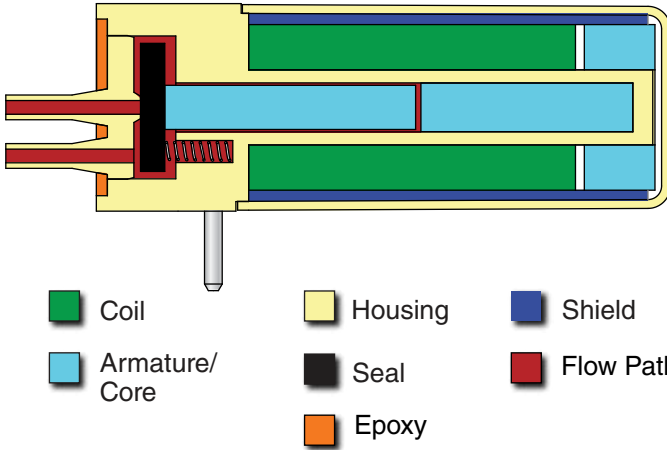

B

	WETTED MATERIALS ³				
	HOUSING	ARMATURE	CORE	SPRING	ELASTOMER
	PBT	430 SS	430 SS	302 SS	CR
	PBT	430 SS	430 SS	302 SS	SI
	PBT	430 SS	430 SS	302 SS	CR
	PBT	430 SS	430 SS	302 SS	SI
	PBT	430 SS	430 SS	302 SS	SI

(2) Refer to Engineering Section, [page S3](#) for a full description of the Lohm Laws.

(3) Refer to Engineering Section, [pages S61-62](#) for material information and abbreviations. Epoxy is used in the valve assembly and therefore considered a wetted material.

(4) See [page B12](#) for complete electrical characteristics.

3-Way Ported Style with Lead Wires

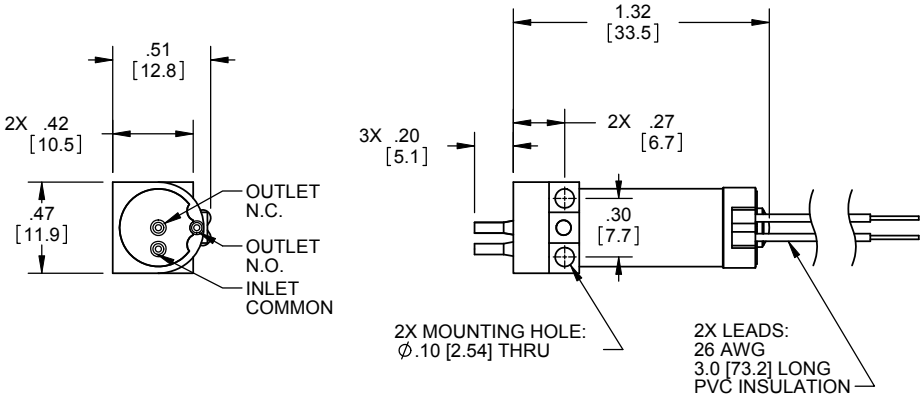

Unless otherwise specified, dimensions are in inches [mm].

PART NUMBER ¹	PORT OUTER DIAMETER	OPERATING PRESSURE (psig)	POWER CONSUMPTION (mW)	LOHM RATE ²		
				C-N.C.	C-N.O.	
LFAA__00110H	.080" (2.03 mm)	0 – 10	280	1000	1300	
LFAA__00310H	.080" (2.03 mm)	12-18 (Charge Vent)	490	1000	1300	
LFAA__01410H	.080" (2.03 mm)	0 – 10	280	1000	1300	
LFAA__01810H	.080" (2.03 mm)	12-18 (Charge Vent)	490	1000	1300	
LFAA__07110H	.080" (2.03 mm)	0 – 10	280	1000	1300	
LFAA__00118H	.054" (1.37 mm)	0 – 10	280	1800	1800	
LFAA__00318H	.054" (1.37 mm)	12-18 (Charge Vent)	490	1800	1800	
LFAA__01418H	.054" (1.37 mm)	0 – 10	280	1800	1800	
LFAA__01818H	.054" (1.37 mm)	12-18 (Charge Vent)	490	1800	1800	
LFAA__07118H	.054" (1.37 mm)	0 – 10	280	1800	1800	

NOTES: (1) Most solenoid valves are available in 5, 9, 12 and 24 vdc configurations.

LFAA__00110H

↑
Coil Voltage: 05 = 5 vdc / 09 = 9 vdc
12 = 12 vdc / 24 = 24 vdc

3-Way Ported Style with Lead Wires

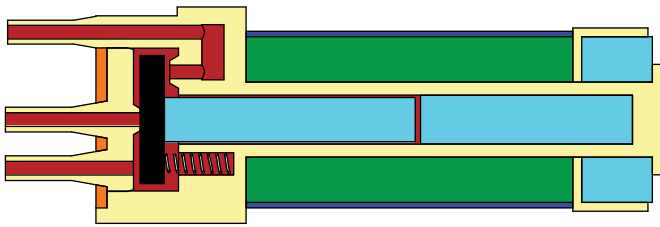

B

	WETTED MATERIALS ³				
	HOUSING	ARMATURE	CORE	SPRING	ELASTOMER
	PBT	430 SS	430 SS	302 SS	CR
	PBT	430 SS	430 SS	302 SS	CR
	PBT	430 SS	430 SS	302 SS	SI
	PBT	430 SS	430 SS	302 SS	SI
	PBT	430 SS	430 SS	316 SS	EPDM
	PBT	430 SS	430 SS	302 SS	CR
	PBT	430 SS	430 SS	302 SS	CR
	PBT	430 SS	430 SS	302 SS	SI
	PBT	430 SS	430 SS	302 SS	SI
	PBT	430 SS	430 SS	316 SS	EPDM

(2) Refer to Engineering Section, [page S3](#) for a full description of the Lohm Laws.

(3) Refer to Engineering Section, [pages S61-62](#) for material information and abbreviations.
Epoxy is used in the valve assembly and therefore considered a wetted material.

(4) See [page B12](#) for complete electrical characteristics.

3-Way Ported Style with Circuit Board Mounts

B

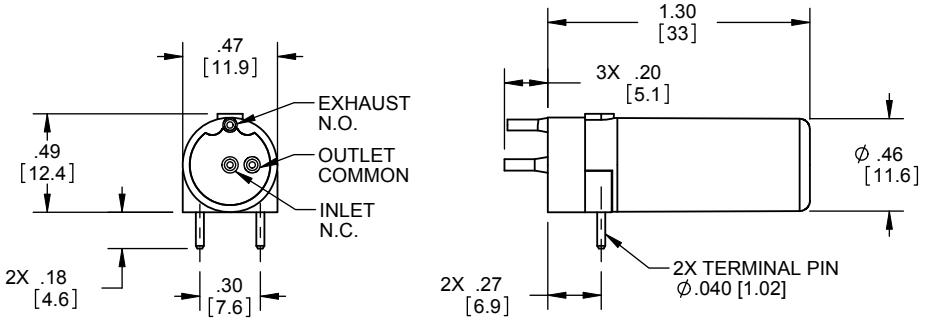

Unless otherwise specified, dimensions are in inches [mm].

PART NUMBER ¹	PORT OUTER DIAMETER	OPERATING PRESSURE (psig)	POWER CONSUMPTION (mW)	LOHM RATE ²	
				C-N.C.	C-N.O.
LFAA__03110H	.080" (2.03 mm)	0 – 10	280	1000	1300
LFAA__03310H	.080" (2.03 mm)	12-18 (Charge Vent)	490	1000	1300
LFAA__03410H	.080" (2.03 mm)	0 – 10	280	1000	1300
LFAA__03810H	.080" (2.03 mm)	0 – 10	490	1000	1300
LFAA__03118H	.054" (1.37 mm)	0 – 10	280	1800	1800
LFAA__03318H	.054" (1.37 mm)	12-18 (Charge Vent)	490	1800	1800
LFAA__03418H	.054" (1.37 mm)	0 – 10	280	1800	1800
LFAA__03818H	.054" (1.37 mm)	0 – 10	490	1800	1800
LFAA__09415H	.080" (2.03 mm)	Vac – 30 (0 - 10 psid)	780	1200	1500

NOTES: (1) Most solenoid valves are available in 5, 9, 12 and 24 vdc configurations.

LFAA__03110H



Coil Voltage: 05 = 5 vdc / 09 = 9 vdc
12 = 12 vdc / 24 = 24 vdc

3-Way Ported Style with Circuit Board Mounts

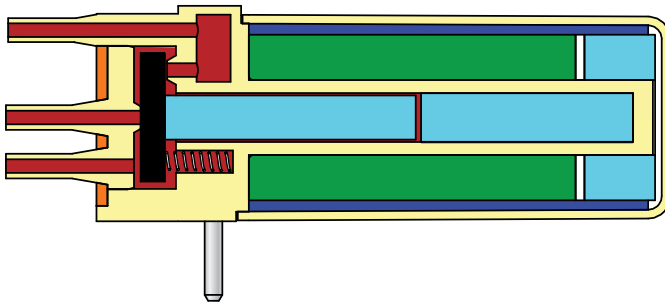

B

WETTED MATERIALS ³					
	HOUSING	ARMATURE	CORE	SPRING	ELASTOMER
	PBT	430 SS	430 SS	302 SS	CR
	PBT	430 SS	430 SS	302 SS	CR
	PBT	430 SS	430 SS	302 SS	SI
	PBT	430 SS	430 SS	302 SS	SI
	PBT	430 SS	430 SS	302 SS	CR
	PBT	430 SS	430 SS	302 SS	CR
	PBT	430 SS	430 SS	302 SS	SI
	PBT	430 SS	430 SS	302 SS	SI
	PBT	430 SS	430 SS	302 SS	SI

- (2) Refer to Engineering Section, [page S3](#) for a full description of the Lohm Laws.
- (3) Refer to Engineering Section, [pages S61-62](#) for material information and abbreviations. Epoxy is used in the valve assembly and therefore considered a wetted material.
- (4) See [page B12](#) for complete electrical characteristics.

GENERAL SPECIFICATIONS

The following specifications apply to all LFA Series valves, unless otherwise noted.

Leakage

Maximum of 50 μL /minute of air at 70°F with 5 psig applied to the common port.

Internal Volume

2-WAY PORTED STYLE		3-WAY PORTED STYLE	
0.054" Port \varnothing	0.080" Port \varnothing	0.054" Port \varnothing	0.080" Port \varnothing
82 μL	93 μL	99 μL	118 μL

Weight

The valves weigh only 11 grams.

Life Expectancy

The valves will typically operate up to 200 million cycles on air, depending on the seal material and application parameters.

Operating Pressure

- Normal Pressure Range: The valves will operate within the normal pressure range when supplied with the rated voltage $\pm 5\%$. The normally closed port seal is spring loaded, so the pressure applied to this port should not exceed the pressure on the common port or the normally open port (except for charge vent valves) by more than 8 psid (55 kPa).
- Extended Pressure Range: The valves can operate in the extended pressure range if higher voltage is applied. Up to 1.6 times rated voltage may be used continuously for 280 mW models. Up to 1.25 times the rated voltage may be used continuously with 490 mW models. The 780 mW valves should not be operated continuously above rated voltage.

Refer to the Operating Pressure chart below for extended pressures.

Valve Proof Pressure: 30 psig (207 kPa)

Valve Burst Pressure: 100 psig (690 kPa)

VALVE TYPE	NORMAL PRESSURE RANGE	EXTENDED PRESSURE RANGE
2-Way NC	8 psia (vacuum) to 7 psig pressure (21.7 psia)	1.5 psia (vacuum) to 20 psig pressure (34.7 psia)
3-Way	5 psia (vacuum) to 10 psig pressure (24.7 psia)	1.5 psia (vacuum) to 30 psig pressure (44.7 psia)

Operating Temperature

- Ambient operating temperature range is 40°F to 120°F (4°C to 49°C).

MEAN POWER (mW)	TEMP. RISE AT 100% DUTY 72°F AMBIENT	MAX. AMBIENT TEMPERATURES	
		100% DUTY	75% - 0% DUTY
280	30°F (17°C)	120°F (49°C)	120°F (49°C)
490	45°F (25°C)	120°F (49°C)	120°F (49°C)
780	55°F (30°C)	110°F (43°C)	120°F (49°C)

- Increasing the operating temperature tends to limit coil performance. The valve duty cycle and energize time must be evaluated for conformance with the maximum recommended operating and coil temperatures. This is most important when operating in the extended range.

Response Time

- Typical response times in milliseconds are as follows:

FLUID	@ RATED VOLTAGE		@ 3X RATED VOLTAGE	
	ENERGIZE	DE-ENERGIZE	ENERGIZE	DE-ENERGIZE
Air	4.5	2.5	1.5	3.5
Water	10.0	13.5	2.5	14.5

- Response times can be enhanced with the use of high speed drive circuits. Refer to Engineering Section, [page S38](#).

Port Connections

The tube ports are straight 0.054" (1.37 mm) or 0.080" (2.03 mm) in diameter, and are designed for PVC or other soft tubing.

Mounting Information

- Surface mount valves use #2 or 2 mm screws allowing 0.42" (10.7 mm) of screw length for valve thickness. Torque screws to 15 in-oz (0.11 N-m) maximum. Nylon screws, Part Number LHWX0203300A, are available to prevent valve damage from over-torquing.
- Printed circuit board mounting is available on select models per the Valve Selection Charts. See [page B14](#) for mounting sockets.
- 0.500" (121.7 mm) minimum center to center mounting distance is recommended.

Filtration

Filtration of 35 microns or finer is recommended.

Electrical Characteristics

The following chart describes the basic electrical characteristics for the LFA Series valves. Refer to Engineering Section, [pages S35-43](#) for special drive circuits.

NORMAL OPERATING RANGE			INDUCTANCE (mH)	EXTENDED OPERATING RANGE		
POWER AT RATED VOLTAGE (mW)	VOLTAGE (vdc)	COIL RESISTANCE (ohms)		MAX. CONTINUOUS VOLTAGE (vdc)	MAX. CONTINUOUS POWER (mW)	MAX. INTERMITTENT VOLTAGE (vdc)
280	24	2,080	2,600	38	780	144
280	12	500	660	19	780	72
280	5	85	90	8	780	30
490	24	1,180	1,200	30	780	144
490	12	295	310	15	780	72
490	5	51	50	6	780	30
780	24	738	900	24	780	144
780	12	185	220	12	780	72
780	5	32	30	5	780	30

Typical Flow Characteristics (LFA Series Valves)

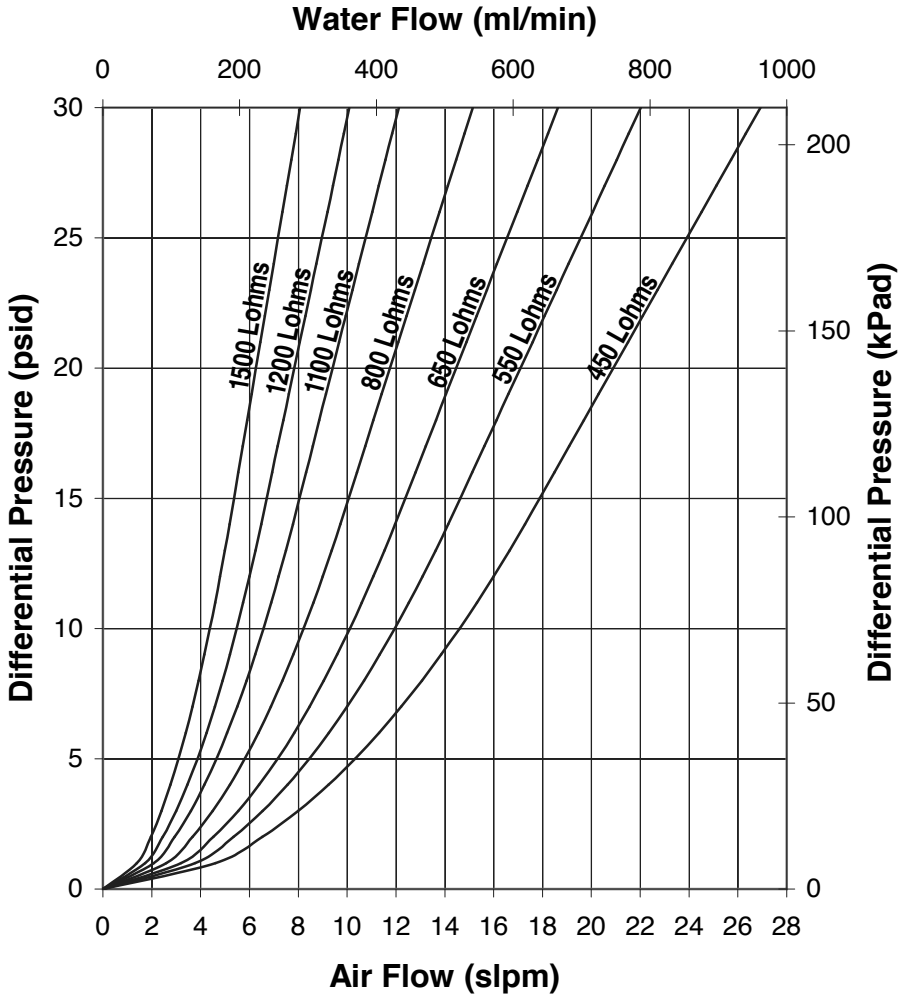

**General Accessories /
Replacement Parts**

PART NUMBER	DESCRIPTION
LFFA4202035A	Filter, 35 Micron
TUVA4220900A	PVC tubing, 0.042" ID, 0.20" wall thickness, for use with 0.054" ports
TUVA6231900A	PVC tubing, 0.062" ID, 0.31" wall thickness, for use with 0.080" ports
LHWX0204550A	PC Board Socket, 0.040" Dia. Pins
LHWX0203300A	Screw, #2 x 5/8", Nylon
LHWX0203770A	Screw, #2 x 1", Nylon
LHWX0503010A	Screw, Socket Head, #2 x 1/4", SS
LHWX0203530A	Plastic Coil Clip with Pressure Sensitive Adhesive

B

VHS Series



The Lee VHS valves are high speed, 2-way solenoid operated valves designed for applications requiring microliter and nanoliter dispense volumes. These applications include high throughput screening and drug discovery.

The VHS valves feature:

- High speed operation: up to 1200 Hz
- Long life: 250 million cycles minimum
- Fast response: some models as fast as 0.25 ms
- Operating pressures up to 120 psi
- Wide range of seal materials

The VHS Series valves are offered in numerous porting and mounting configurations:

- 062 MINSTAC for use with Teflon® tubing
- 1/32" barb for use with soft push on tubing
- Manifold mounting
- Direct dispense outlet (precision jeweled orifice)
- Small outlet ports

Lee also offers a variety of accessories such as nozzles and safety screens to further enhance the valve's operation.

Standard materials and configurations are shown on the following pages. The Lee Company can also customize valves to meet specific application requirements.

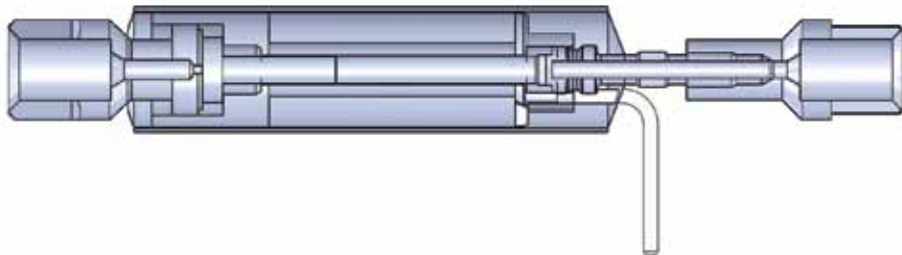

062 MINSTAC Inlet / 062 MINSTAC Outlet (M/M)

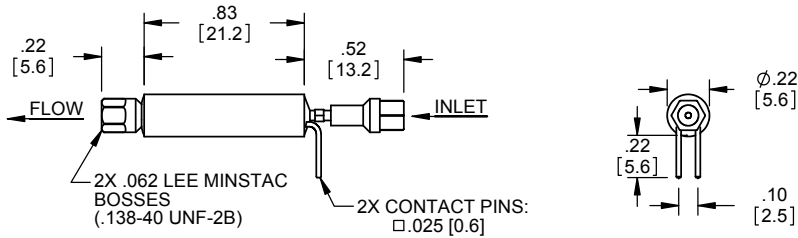

Unless otherwise specified, dimensions are in inches [mm].

VHS M/M valves are designed for use with 062 MINSTAC fittings. Easy connections to Teflon tubing can be made on the inlet port and nozzles can be threaded directly into the outlet port (see [Section M](#)).

- Flow restriction: 4750 Lohms ($C_v = 0.004$)
- Weight: 1.8 grams
- Internal Volume: 40 microliters
- Wetted materials (in addition to seal): Stainless Steel, PEEK, PPS, Epoxy

PART NUMBER	SPIKE VOLTAGE (vdc)	MAXIMUM HOLD VOLTAGE (vdc)	RECOMMENDED HOLD VOLTAGE (vdc)	MIN. SPIKE DURATION ¹ (ms)	PRESSURE (psig)	SEAL MATERIAL
INKX0511400A	12	2.3	1.6	0.35	120	EPDM
INKX0514300A	24	4.5	3.2	0.35	120	EPDM
INKX0511850A	12	2.3	1.6	0.5	120	FKM
INKX0517500A	24	4.5	3.2	0.5	120	FKM
INKX0516350A	12	2.3	1.6	0.5	10	FFKM
INKX0514100A	24	4.5	3.2	0.5	10	FFKM
INKX0507900A	12	2.3	1.6	0.25	120	SI
INKX0507950A	24	4.5	3.2	0.25	120	SI

NOTES: (1) Refer to [page C17](#) for complete electrical characteristics.

062 MINSTAC Inlet / Standard Port Outlet (M/P)

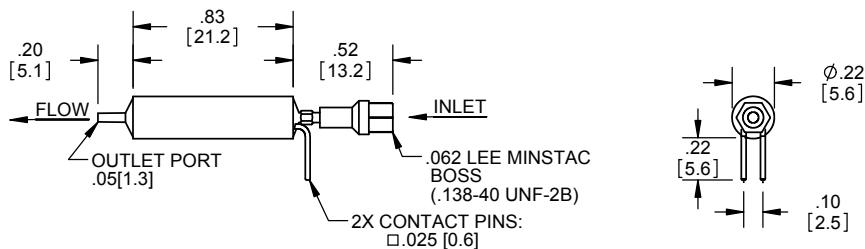

Unless otherwise specified, dimensions are in inches [mm].



VHS M/P valves are designed for use with 062 MINSTAC fittings on the inlet port, allowing easy connections to Teflon tubing. The outlet port is designed for 1/32" ID soft (flexible) tubing which can be connected to a downstream 0.050" OD Hypo Tube nozzle. The flexible connection permits the nozzles to be placed closer than the valve center to center mounting.

- Flow restriction: 4750 Lohms (Cv = 0.004)
- Weight: 1.8 grams
- Internal Volume: 35 microliters
- Wetted materials (in addition to seal): Stainless Steel, PEEK, PPS, Epoxy

PART NUMBER	SPIKE VOLTAGE (vdc)	MAXIMUM HOLD VOLTAGE (vdc)	RECOMMENDED HOLD VOLTAGE (vdc)	MIN. SPIKE DURATION ¹ (ms)	PRESSURE (psig)	SEAL MATERIAL
INKX0511950A	12	2.3	1.6	0.35	120	EPDM
INKX0514750A	24	4.5	3.2	0.35	120	EPDM
INKX0519850A	12	2.3	1.6	0.5	120	FKM
INKX0508200A	24	4.5	3.2	0.5	120	FKM
INKX0512700A	12	2.3	1.6	0.5	10	FFKM
INKX0516450A	24	4.5	3.2	0.5	10	FFKM
INKX0508250A	12	2.3	1.6	0.25	120	SI
INKX0508300A	24	4.5	3.2	0.25	120	SI

NOTES: (1) Refer to [page C17](#) for complete electrical characteristics.

062 MINSTAC Inlet / Small Port Outlet (M/SP)

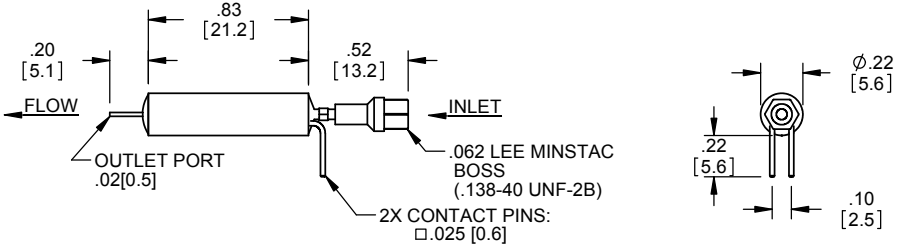

Unless otherwise specified, dimensions are in inches [mm].

VHS M/SP valves are designed for use with 062 MINSTAC fittings on the inlet port, allowing easy connections to Teflon tubing. The outlet port may be used for direct dispensing. For greater accuracy, a nozzle may be connected to the outlet using soft tubing (see [Section M](#)).

- Flow restriction: 11,000 Lohms (Cv = 0.001)
- Weight: 1.8 grams
- Internal Volume: 35 microliters
- Wetted materials (in addition to seal): Stainless Steel, PEEK, PPS, Epoxy

PART NUMBER	SPIKE VOLTAGE (vdc)	MAXIMUM HOLD VOLTAGE (vdc)	RECOMMENDED HOLD VOLTAGE (vdc)	MIN. SPIKE DURATION ¹ (ms)	PRESSURE (psig)	SEAL MATERIAL
INKX0514900A	12	2.3	1.6	0.35	120	EPDM
INKX0514950A	24	4.5	3.2	0.35	120	EPDM
INKX0514650A	12	2.3	1.6	0.5	120	FKM
INKX0508350A	24	4.5	3.2	0.5	120	FKM
INKX0516200A	12	2.3	1.6	0.5	10	FFKM
INKX0516250A	24	4.5	3.2	0.5	10	FFKM
INKX0516100A	12	2.3	1.6	0.25	120	SI
INKX0508400A	24	4.5	3.2	0.25	120	SI

NOTES: (1) Refer to [page C17](#) for complete electrical characteristics.

Standard Port Inlet / 062 MINSTAC Outlet (P/M)

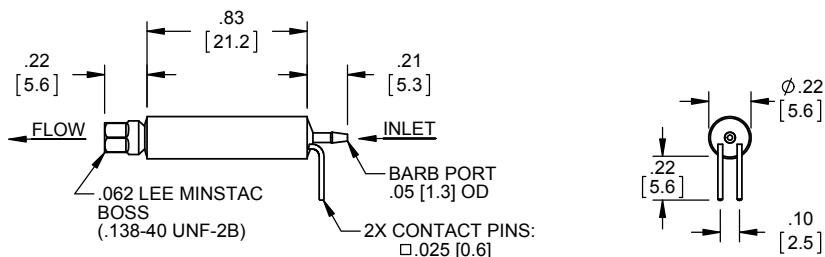

Unless otherwise specified, dimensions are in inches [mm].



VHS P/M valves are designed for use with 1/32" ID soft (flexible) tubing on the inlet port. The 062 MINSTAC outlet boss allows for the use of threaded nozzles. Nozzles are easily interchanged to allow for different dispense ranges, or for cleaning (see [Section M](#)).

- Flow restriction: 4750 Lohms (Cv = 0.004)
- Weight: 1.8 grams
- Internal Volume: 35 microliters
- Wetted materials (in addition to seal): Stainless Steel, PEEK, PPS, Epoxy

PART NUMBER	SPIKE VOLTAGE (vdc)	MAXIMUM HOLD VOLTAGE (vdc)	RECOMMENDED HOLD VOLTAGE (vdc)	MIN. SPIKE DURATION ¹ (ms)	PRESSURE (psig)	SEAL MATERIAL
INKX0514800A	12	2.3	1.6	0.35	10	EPDM
INKX0514850A	24	4.5	3.2	0.35	10	EPDM
INKX0508000A	12	2.3	1.6	0.5	10	FKM
INKX0508050A	24	4.5	3.2	0.5	10	FKM
INKX0515000A	12	2.3	1.6	0.5	10	FFKM
INKX0515050A	24	4.5	3.2	0.5	10	FFKM
INKX0508100A	12	2.3	1.6	0.25	10	SI
INKX0508150A	24	4.5	3.2	0.25	10	SI

NOTES: (1) Refer to [page C17](#) for complete electrical characteristics.

Standard Port Inlet / Standard Port Outlet (P/P)

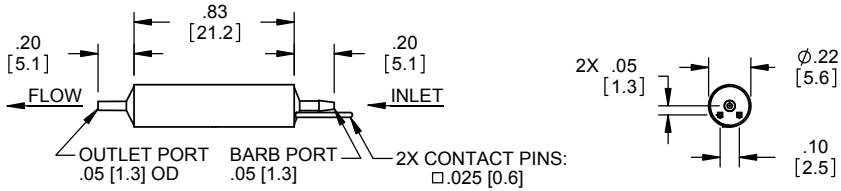

Unless otherwise specified, dimensions are in inches [mm].

VHS P/P valves are designed for use with 1/32" ID soft (flexible) tubing. This allows nozzles to be placed closer than the actual valve center to center distance. Separate nozzles allow for fine tuning of the dispense volume range (see [Section M](#)).

- Flow restriction: 4750 Lohms ($C_v = 0.004$)
- Weight: 1.8 grams
- Internal Volume: 30 microliters
- Wetted materials (in addition to seal): Stainless Steel, PEEK, PPS, Epoxy

PART NUMBER	SPIKE VOLTAGE (vdc)	MAXIMUM HOLD VOLTAGE (vdc)	RECOMMENDED HOLD VOLTAGE (vdc)	MIN. SPIKE DURATION ¹ (ms)	PRESSURE (psig)	SEAL MATERIAL
INKA1224212H	12	2.3	1.6	0.35	10	EPDM
INKA2424212H	24	4.5	3.2	0.35	10	EPDM
INKX0508450A	12	2.3	1.6	0.5	10	FKM
INKX0514550A	24	4.5	3.2	0.5	10	FKM
INKX0511900A	12	2.3	1.6	0.5	10	FFKM
INKX0516550A	24	4.5	3.2	0.5	10	FFKM
INKX0508500A	12	2.3	1.6	0.25	10	SI
INKX0508550A	24	4.5	3.2	0.25	10	SI

NOTES: (1) Refer to [page C17](#) for complete electrical characteristics.

Standard Port Inlet / Small Port Outlet (P/SP)

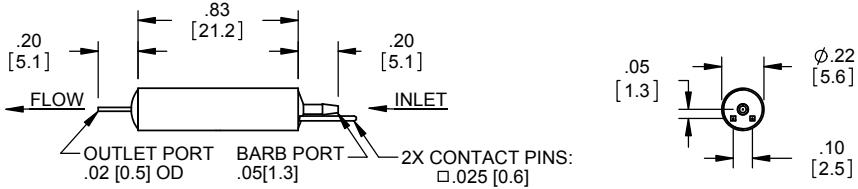

Unless otherwise specified, dimensions are in inches [mm].

VHS P/SP valves are designed for use with 1/32" ID soft (flexible) tubing on the inlet port. The outlet port can be used for direct dispensing. If smaller volumes and greater accuracy is desired, jeweled nozzles can be attached to the valve with tubing (see [Section M](#)). This allows nozzles to be placed closer than the actual valve center to center distance.

- Flow restriction: 11000 Lohms (Cv = 0.001)
- Weight: 1.8 grams
- Internal Volume: 30 microliters
- Wetted materials (in addition to seal): Stainless Steel, PEEK, PPS, Epoxy

PART NUMBER	SPIKE VOLTAGE (vdc)	MAXIMUM HOLD VOLTAGE (vdc)	RECOMMENDED HOLD VOLTAGE (vdc)	MIN. SPIKE DURATION ¹ (ms)	PRESSURE (psig)	SEAL MATERIAL
INKA1226212H	12	2.3	1.6	0.35	10	EPDM
INKA2426212H	24	4.5	3.2	0.35	10	EPDM
INKX0508600A	12	2.3	1.6	0.5	10	FKM
INKX0508650A	24	4.5	3.2	0.5	10	FKM
INKX0507000A	12	2.3	1.6	0.5	10	FFKM
INKX0516500A	24	4.5	3.2	0.5	10	FFKM
INKX0508700A	12	2.3	1.6	0.25	10	SI
INKX0508750A	24	4.5	3.2	0.25	10	SI

NOTES: (1) Refer to [page C17](#) for complete electrical characteristics.

062 MINSTAC Inlet Port / Direct Dispense Outlet

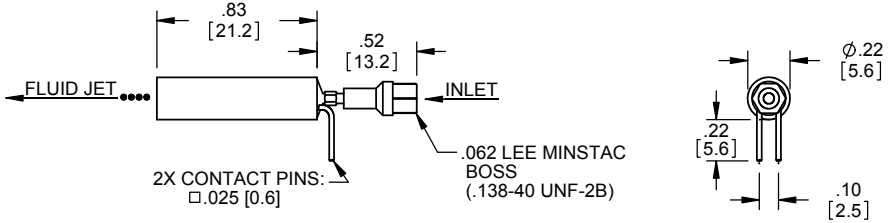







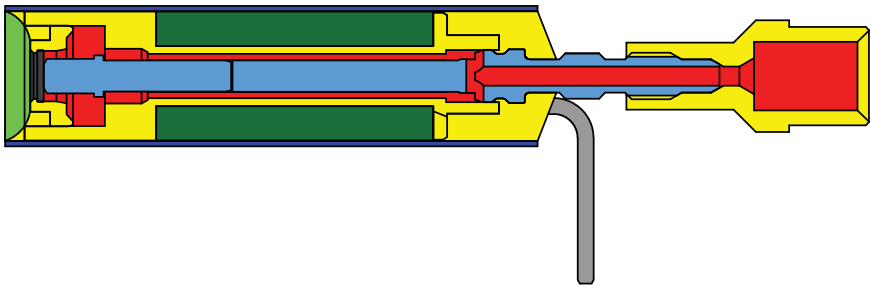

Unless otherwise specified, dimensions are in inches [mm].

MINSTAC direct dispense valves are available in two different styles (LT and VJ), both allowing repeatable direct dispensing from the valve without the need for an additional nozzle. The 062 MINSTAC inlet port allows the valve to be used with Teflon® tubing and the Lee 062 MINSTAC Fitting System.

The LT style has a sapphire orifice plate and incorporates an internal pressure compensation bladder. This allows the droplet to retain its integrity longer and travel further. The VJ style does not have a pressure bladder. This reduces the throw distance slightly, but makes the valve easier to flush.



- | | | |
|--|--|--|
|  Sapphire Orifice |  Housing |  Shield |
|  Armature/Plunger |  Coil |  Fluid |
|  Seal |  Electrical Pin | |

062 MINSTAC Inlet Port / Direct Dispense Outlet

PART NUMBER	STYLE	ORIFICE DIAMETER	SEAL MATERIAL	LOHMS	MIN. SPIKE DURATION (ms)	PRESSURE (psig)
INKA2435010H	LT	0.003" (0.076 mm)	SI/BUTYL	110,000	0.35	30
INKA2455010H	LT	0.005" (0.127 mm)	SI/BUTYL	50,000	0.35	30
INKA2475010H	LT	0.007" (0.178 mm)	SI/BUTYL	21,000	0.35	30
INKA2435210H	LT	0.003" (0.076 mm)	EPDM/BUTYL	110,000	0.35	30
INKA2455210H	LT	0.005" (0.127 mm)	EPDM/BUTYL	50,000	0.35	30
INKA2475210H	LT	0.007" (0.178 mm)	EPDM/BUTYL	21,000	0.35	30
INKA2435110H	LT	0.003" (0.076 mm)	FKM/BUTYL	110,000	0.5	30
INKA2455110H	LT	0.005" (0.127 mm)	FKM/BUTYL	50,000	0.5	30
INKA2475110H	LT	0.007" (0.178 mm)	FKM/BUTYL	21,000	0.5	30
INKA2435510H	LT	0.003" (0.076 mm)	FFKM/BUTYL	110,000	0.5	30
INKA2455510H	LT	0.005" (0.127 mm)	FFKM/BUTYL	50,000	0.5	30
INKA2475510H	LT	0.007" (0.178 mm)	FFKM/BUTYL	21,000	0.5	30
INKA2436010H	VJ	0.003" (0.076 mm)	SI	110,000	0.35	120
INKA2456010H	VJ	0.005" (0.127 mm)	SI	50,000	0.35	120
INKA2476010H	VJ	0.007" (0.178 mm)	SI	21,000	0.35	120
INKA2436210H	VJ	0.003" (0.076 mm)	EPDM	110,000	0.35	120
INKA2456210H	VJ	0.005" (0.127 mm)	EPDM	50,000	0.35	120
INKA2476210H	VJ	0.007" (0.178 mm)	EPDM	21,000	0.35	120
INKA2436110H	VJ	0.003" (0.076 mm)	FKM	110,000	0.5	120
INKA2456110H	VJ	0.005" (0.127 mm)	FKM	50,000	0.5	120
INKA2476110H	VJ	0.007" (0.178 mm)	FKM	21,000	0.5	120
INKA2436510H	VJ	0.003" (0.076 mm)	FFKM	110,000	0.5	120
INKA2456510H	VJ	0.005" (0.127 mm)	FFKM	50,000	0.5	120
INKA2476510H	VJ	0.007" (0.178 mm)	FFKM	21,000	0.5	120

- Weight: 1.8 grams
- Internal Volume: LT Style: 35 µL
VJ Style: 60 µL
- Pulse Voltage: 24 vdc
- Hold Voltage: 7.5 vdc (maximum), 5.0 vdc (recommended)
- Wetted materials (in addition to seal): Stainless Steel, PEEK, PPS, Sapphire, Epoxy

Standard Inlet Port / Direct Dispense Outlet

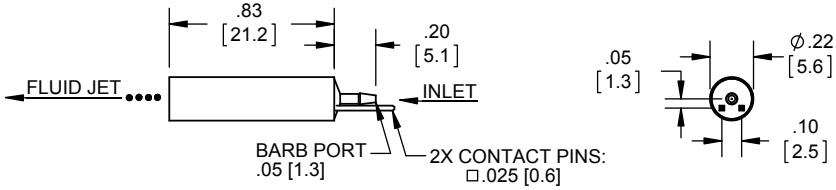







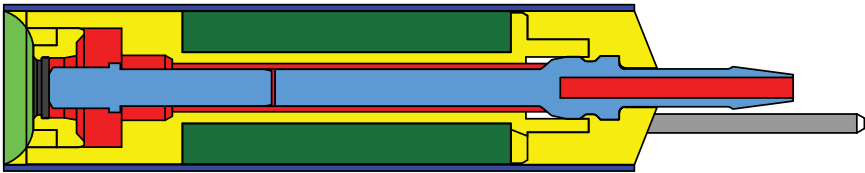

Unless otherwise specified, dimensions are in inches [mm].

Ported direct dispense valves are available in two different styles (LT and VJ), both allowing repeatable direct dispensing from the valve without the need for an additional nozzle. The 0.05" diameter inlet port is designed for use with 1/32" ID soft tubing.

The LT style has a sapphire orifice plate and incorporates an internal pressure compensation bladder. This allows the droplet to retain its integrity longer and travel further. The VJ style does not have a pressure bladder. This reduces the throw distance slightly, but makes the valve easier to flush.



- | | | |
|--|--|--|
|  Sapphire Orifice |  Housing |  Shield |
|  Armature/Plunger |  Coil |  Fluid |
|  Seal |  Electrical Pin | |

Standard Inlet Port / Direct Dispense Outlet

PART NUMBER	STYLE	ORIFICE DIAMETER	SEAL MATERIAL	LOHMS	MIN. SPIKE DURATION (ms)	PRESSURE (psig)
INKA2437010H	LT	0.003" (0.076 mm)	SI/BUTYL	110,000	0.35	30
INKA2457010H	LT	0.005" (0.127 mm)	SI/BUTYL	50,000	0.35	30
INKA2477010H	LT	0.007" (0.178 mm)	SI/BUTYL	21,000	0.35	30
INKA2437210H	LT	0.003" (0.076 mm)	EPDM/BUTYL	110,000	0.35	30
INKA2457210H	LT	0.005" (0.127 mm)	EPDM/BUTYL	50,000	0.35	30
INKA2477210H	LT	0.007" (0.178 mm)	EPDM/BUTYL	21,000	0.35	30
INKA2437110H	LT	0.003" (0.076 mm)	FKM/BUTYL	110,000	0.5	30
INKA2457110H	LT	0.005" (0.127 mm)	FKM/BUTYL	50,000	0.5	30
INKA2477110H	LT	0.007" (0.178 mm)	FKM/BUTYL	21,000	0.5	30
INKA2437510H	LT	0.003" (0.076 mm)	FFKM/BUTYL	110,000	0.5	30
INKA2457510H	LT	0.005" (0.127 mm)	FFKM/BUTYL	50,000	0.5	30
INKA2477510H	LT	0.007" (0.178 mm)	FFKM/BUTYL	21,000	0.5	30
INKA2438010H	VJ	0.003" (0.076 mm)	SI	110,000	0.35	30
INKA2458010H	VJ	0.005" (0.127 mm)	SI	50,000	0.35	30
INKA2478010H	VJ	0.007" (0.178 mm)	SI	21,000	0.35	30
INKA2438210H	VJ	0.003" (0.076 mm)	EPDM	110,000	0.35	30
INKA2458210H	VJ	0.005" (0.127 mm)	EPDM	50,000	0.35	30
INKA2478210H	VJ	0.007" (0.178 mm)	EPDM	21,000	0.35	30
INKA2438110H	VJ	0.003" (0.076 mm)	FKM	110,000	0.5	30
INKA2458110H	VJ	0.005" (0.127 mm)	FKM	50,000	0.5	30
INKA2478110H	VJ	0.007" (0.178 mm)	FKM	21,000	0.5	30
INKA2438510H	VJ	0.003" (0.076 mm)	FFKM	110,000	0.5	30
INKA2458510H	VJ	0.005" (0.127 mm)	FFKM	50,000	0.5	30
INKA2478510H	VJ	0.007" (0.178 mm)	FFKM	21,000	0.5	30

- Weight: 1.8 grams
- Internal Volume: LT Style: 30 μ L
VJ Style: 55 μ L
- Pulse Voltage: 24 vdc
- Hold Voltage: 7.5 vdc (maximum), 5.0 vdc (recommended)
- Wetted materials (in addition to seal): Stainless Steel, PEEK, PPS, Sapphire, Epoxy

Manifold Mount VHS Valves

VHS Series valves with standard or small outlet ports can be manifold mounted. This allows precise, controlled injection of fluids directly into flow streams. The outlet port is placed in close proximity to the flow stream, minimizing captive capillary volumes and increasing the accuracy of the volume of the fluid injected.

Single and multiple valve manifolds are available in PEEK and acrylic. Boss plugs are also available to allow for future system expansion.

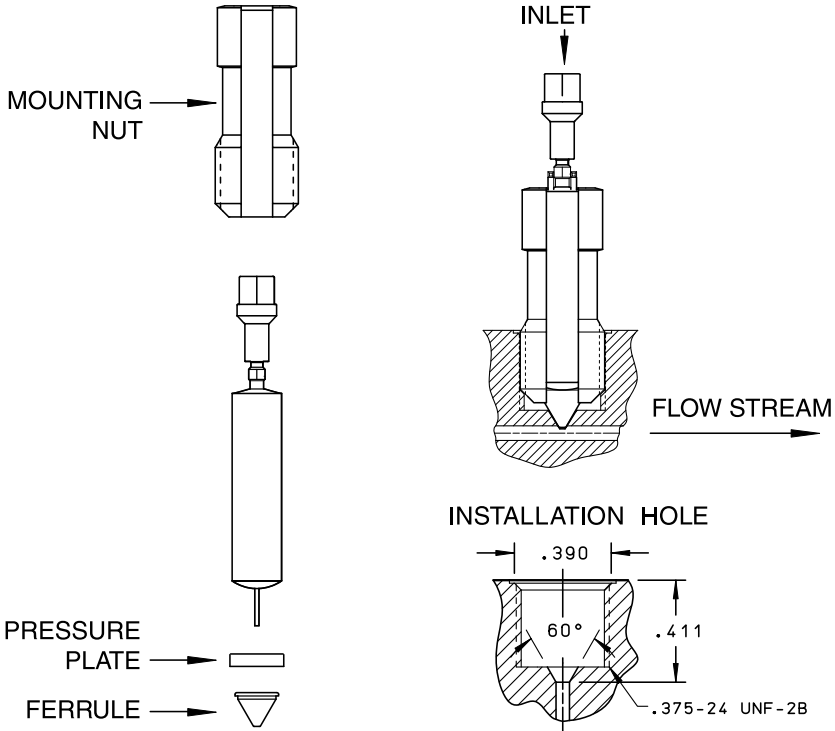

Unless otherwise specified, dimensions are in inches [mm].

A detailed machining drawing for the installation hole (INIX0500050A) is available to assist in the manufacturing of custom manifolds or in-house drawings.

KIT	KIT PART NUMBER	REPLACEMENT FERRULE
Standard Port (0.050" dia)	IKTX0322170A	IHWX0306020A
Small Port (0.020" dia)	IKTX0322200A	IHWX0306040A
Manifold Plug	IKTX0322190A	IHWX0306260A

MANIFOLD CONFIGURATIONS

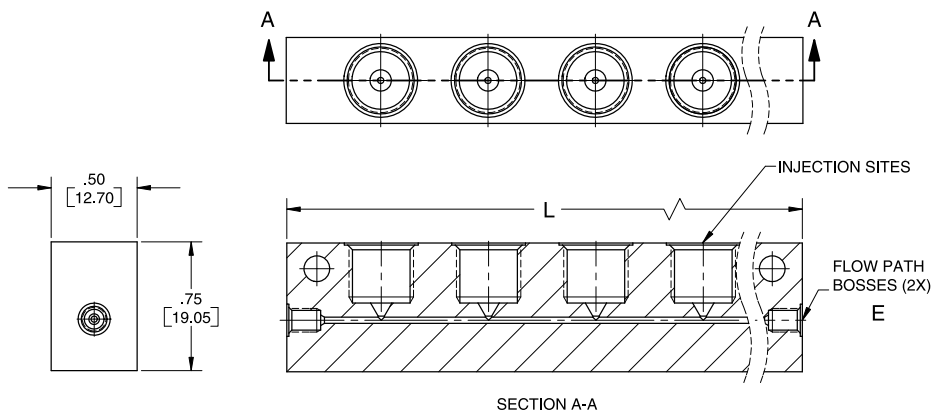

Unless otherwise specified,
dimensions are in inches [mm].

062 MINSTAC Connection Ports

PART NUMBER	MANIFOLD MATERIAL	NUMBER OF VALVES	LENGTH "L"
INMA0602310B	PEEK	1	1.10" (27.9 mm)
INMA0602320B	PEEK	2	1.73" (43.9 mm)
INMA0602330B	PEEK	3	2.35" (59.7 mm)
INMA0602340B	PEEK	4	2.98" (75.7 mm)
INMA0601310B	PMMA	1	1.10" (27.9 mm)
INMA0601320B	PMMA	2	1.73" (43.9 mm)
INMA0601330B	PMMA	3	2.35" (59.7 mm)
INMA0601340B	PMMA	4	2.98" (75.7 mm)

1/4-28 Flat Bottom Boss

PART NUMBER	MANIFOLD MATERIAL	NUMBER OF VALVES	LENGTH "L"
INMA0602410B	PEEK	1	1.10" (27.9 mm)
INMA0602420B	PEEK	2	1.73" (43.9 mm)
INMA0602430B	PEEK	3	2.35" (59.7 mm)
INMA0602440B	PEEK	4	2.98" (75.7 mm)
INMA0601410B	PMMA	1	1.10" (27.9 mm)
INMA0601420B	PMMA	2	1.73" (43.9 mm)
INMA0601430B	PMMA	3	2.35" (59.7 mm)
INMA0601440B	PMMA	4	2.98" (75.7 mm)

VHS Hard Seat Valves

VHS Hard Seat Valves replace the elastomeric seals with a precision zirconia ball and seat. These valves offer precise, repeatable, non-contact dispensing in the nanoliter and microliter range. They are well suited for DMSO and other fluids that negatively react with elastomers.

- High Speed Operation
- Fluid Applications Only
- Wetted Materials: Stainless steel, PEEK, TZP
- 2 way, Normally Closed Operation
- Available in 12 and 24 vdc models (spike and hold circuit required)

- Inlet ports: 062 MINSTAC
- Outlet ports
 - 062 MINSTAC for connection of nozzles or tubing (Configuration A)
 - 0.05" O.D. port for use with flexible tubing or direct dispensing (Configuration B)
 - Jeweled orifice for direct dispensing (Configuration C)
- Weight: 1.8 grams

PART NUMBER ¹	CONFIGURATION	OUTLET PORT	LOHM RATE ²	INTERNAL VOLUME
INKA__83410H	A	062 MINSTAC	6250	40 μ L
INKA__03410H	B	0.05" O.D. port	5000	37 μ L
INKA__43410H	C	0.004" I.D. jewel	60,000	35 μ L
INKA__53410H	C	0.005" I.D. jewel	35,000	35 μ L
INKA__73410H	C	0.0075" I.D. jewel	15,400	35 μ L

NOTES: (1) Solenoid valves available in 12 and 24 vdc configurations.

INKA__83410H

↑
 _____ Coil Voltage: 12 = 12 vdc
 24 = 24 vdc

(2) Refer to Engineering Section, [page S3](#) for a full description of the Lohm Laws.

Configuration A

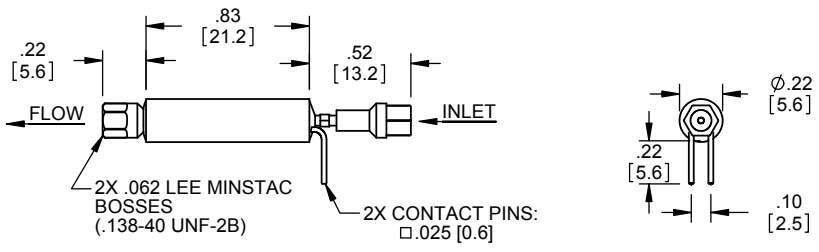

Configuration B

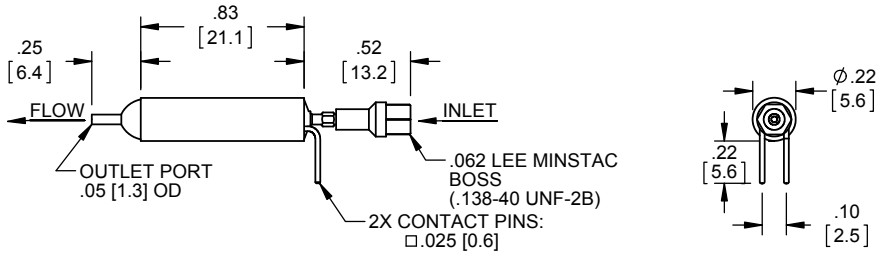

Configuration C

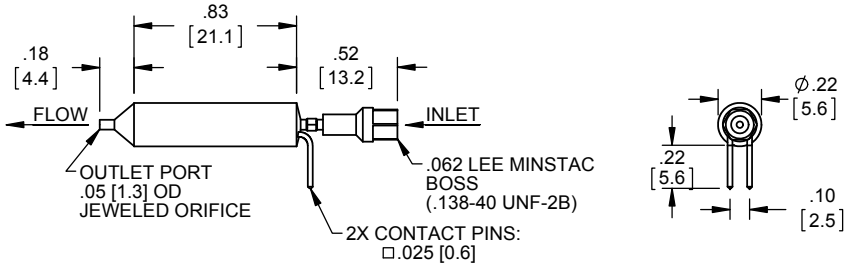

Unless otherwise specified, dimensions are in inches [mm].



GENERAL SPECIFICATIONS

The following specifications apply to all VHS Series solenoid valves, unless otherwise noted.

Cycle Life

VHS valves will operate for a minimum of 250 million cycles on water. Flow media and system conditions may affect performance.

Standard VHS valves are designed for operation on liquids. For air or gas operations, contact The Lee Company for special models.

C

Electrical Characteristics

The VHS valves require a spike and hold signal for proper operation. This will prevent damage to the coil.

Spike and hold drive circuit modules are available (IECX0501350A) for use with VHS valves. See [page C20](#) for complete starter kit.

A schematic for a "typical" spike and hold drive circuit (H-wave) can be found in the Engineering Section, [page S37](#).

There is no polarity associated with the valve pins.

	STANDARD 12 VOLT COIL	STANDARD 24 VOLT COIL	DIRECT DISPENSE 24 VOLT COIL
Resistance (ohms)	10.6	40	110
Inductance: energized (mH)	3.6	16	38
Inductance: de-energized (mH)	2.8	12	20

Operating Pressure

- Valves are designed to operate within the normal ranges listed in this handbook.

Proof Pressure 2 x normal operating pressure

Burst Pressure 3 x normal operating pressure

- Special higher pressure valves can be designed. Contact The Lee Company for specifications.

Operating Temperature

- Ambient operating temperature range is 40°F - 120°F (4°C - 49°C)
- Maximum outside coil temperature not to exceed 150°F (66°C)
- Increasing the operating temperature tends to limit coil performance. Coil temperature is influenced by current and environmental factors such as self-heating, ambient temperature and heat dissipation (heat sinks, active cooling, fluid flow, etc.)
- Special high temperature valves are available

Response Time

- VHS Series valves require a spike and hold drive circuit (H-wave) to operate properly. Failure to reduce the spike voltage will result in damage to the valve. Schematics for these circuits can be found in the Engineering section, [page S37](#).

Purging

- Valves must be free of air (purged) for optimum dispensing performance. This may require a static and/or dynamic purge. Please contact The Lee Company if assistance is needed.

Filtration

System filtration of 12 microns is recommended. In addition, last chance safety screens are available that thread directly into valves with MINSTAC inlet ports. These are last chance screens and are not intended to replace system filters. Improper filtration can result in damage to the valve (leakage) due to contamination of the sealing surface. Refer to MINSTAC Section, [pages L52-53](#).

Accessories

Electrical Connectors

The VHS Series valves use 0.025" electrical pins on 0.100" centers. Standard electrical connectors that fit these dimensions can be used. Lee also offers pre-made lead assemblies.

8": IHWX0248010A

24": IHWX0248120A

Electrical Pin Bending Tool

The Pin Bending Tool (IHWX0256010A) allows the end user to, as the name suggests, bend the electrical pins on VHS Series valves. The tool is intended for prototype work and limited initial production. The Lee Company can provide special part numbers for OEM applications requiring bent pins.

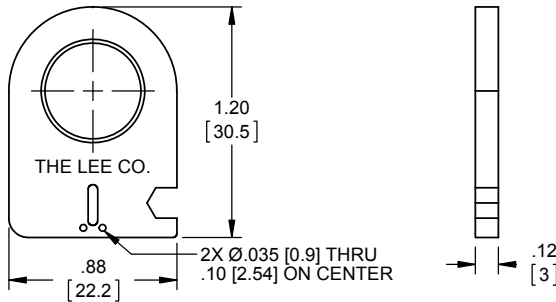

Unless otherwise specified, dimensions are in inches [mm].

Safety Screens

Proper system filtration is critical for the operation of any valve. Lee offers "last chance safety screens" which can be placed directly inline with the valve to prevent stray particles from damaging the valve. They are not meant to act as system filters or replace proper filtration. The screens are available in male to male and male to female configurations. Refer to Engineering Section, [pages L52-53](#) for details.

Nozzles

For optimum dispensing, VHS valves should be used with separate nozzles. Lee offers a full line of threaded 062 MINSTAC nozzles, straight ported nozzles and atomizing nozzles. See [Section M](#) for details.

Starter Kits

Lee offers a VHS Starter Kit for micro dispensing (Part Number IKTX0322000A). This kit provides all of the specialized hardware to set up and run a small dispensing system. The user needs to provide a pressurized fluid source, control signal and power supply. The kit includes:

- High speed dispensing valve (Part Number INKX0514300A)
- Spike / hold electrical driver (Part Number IECX0501350A)
- 3 precision dispensing nozzles
- Atomizing nozzle (Part Number INZX0550050A)
- MINSTAC tubing assembly and components
- Safety screen
- Lead wire assembly (Part Number IHWX0248010A)
- Instructional CD

INK Series

D



The Lee Company is the world leader in providing ink jet valves for drop on demand, large character printing. Featuring high speed, repeatability and long life, the INK Series valves are ideal for a replacement to existing printers or in new drop on demand and dispensing applications.

- Two mounting styles: Axial Pin and PC Board
- 275 Hz and 600 Hz models
- Low power consumption
- Long life, 250 million cycles minimum

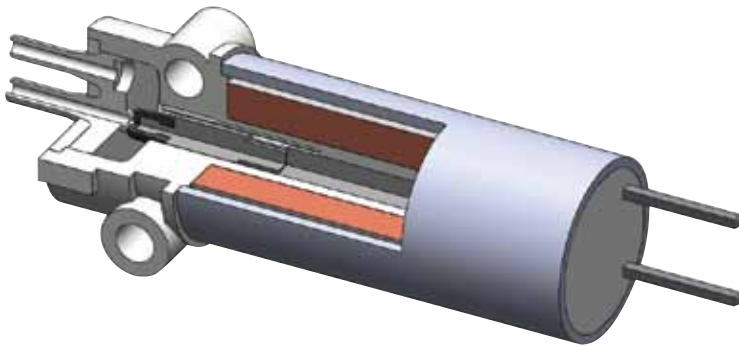

PC Board Mount

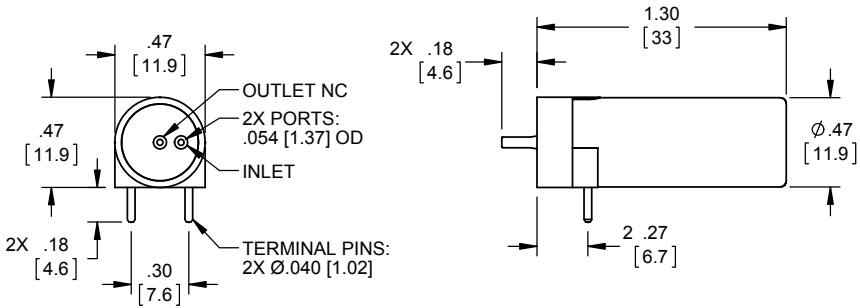

Unless otherwise specified, dimensions are in inches [mm].

D

PART NUMBER	SPIKE VOLTAGE (vdc)	HOLD VOLTAGE (vdc)	MIN. SPIKE DURATION (ms)	AVERAGE POWER (W)	MAX. FREQUENCY (Hz)	SEAL MATERIAL ¹
INKA1202028D	12	3.6	0.65	0.78	275	SI
INKA2402028D	24	7.7	0.65	0.78	275	SI
INKA4002028D	40	12	0.65	0.78	275	SI
INKA1202160D	12	5	0.9	1.02	600	FKM
INKA2402160D	24	10	0.9	1.02	600	FKM
INKA4002160D	40	16	0.9	1.02	600	FKM

NOTE: (1) Wetted materials (in addition to seal): stainless steel, PBT and epoxy

Axial Pin Mount

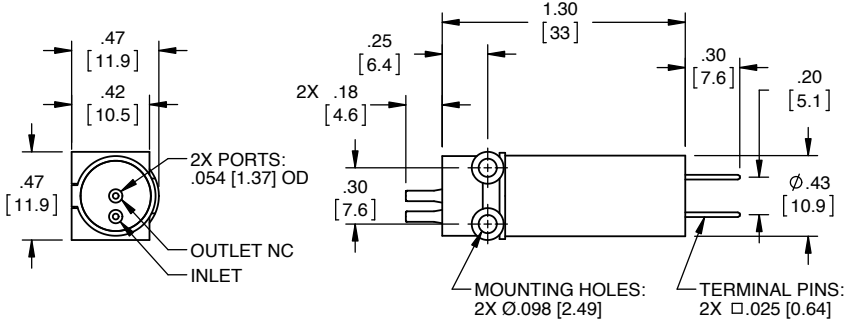

Unless otherwise specified, dimensions are in inches [mm].



PART NUMBER	SPIKE VOLTAGE (vdc)	HOLD VOLTAGE (vdc)	MIN. SPIKE DURATION (ms)	AVERAGE POWER (W)	MAX. FREQUENCY (Hz)	SEAL MATERIAL ¹
INKA1205160D	12	5	0.9	1.02	600	FKM
INKA2405160D	24	10	0.9	1.02	600	FKM
INKA4005160D	40	16	0.9	1.02	600	FKM

NOTE: (1) Wetted materials (in addition to seal): stainless steel, PBT and epoxy

GENERAL SPECIFICATIONS

The following specifications apply to all INK Series valves, unless otherwise noted.

Life Expectancy

The valves will typically operate for a minimum of 250 million cycles on water. Typical life exceeds 500 million on water.

Operating pressure

- Pressure range: vac-10 psig. Pressure exceeding 10 psi will reduce the valve operating speed.
- Valve proof pressure: 20 psi
- Valve burst pressure: 30 psi

Operating Temperature

- Ambient operating temperature range: 40°F to 120°F (4°C to 49°C)
- Maximum coil temperature: 150°F (66°C)
- Increasing operating temperature tends to limit coil performance.
- Valve duty cycle and energized time must be evaluated for conformance with the maximum recommended operating temperature and coil temperature.

Response Time

INK Series valves require a spike and hold drive circuit (refer to Engineering Section, [page S37](#)) to attain rated speeds. Maximum frequency for INK valves is based on the “voltage spike duration” and the use of high speed drive circuits.

Filtration

Filtration of 35 microns or finer is recommended. Contact The Lee Company for additional technical assistance and application information.

Port connections

- INK Series valves are designed for use with soft, flexible tubing. The dispensed droplet is affected by the length of tubing used in the system. Tubing stiffness, I.D., O.D. and chemical compatibility must be considered during system design.
- Lee offers 0.042" I.D., PVC tubing for use with INK Series valves (Part Number TUV4220900A).

Electrical Characteristics

“Spike voltage” is the voltage required to actuate the valve. Spike voltage can be applied for a limited time (several milliseconds) depending on conditions. Longer on-times require the voltage to be reduced to the “holding voltage.” Failure to do so will cause permanent damage to the valve.

High speed drive circuits are necessary to achieve the maximum operating frequency (refer to Engineering Section, [pages S37-S38](#)).

A spike and hold driver (Part Number IECX0501350A) is also available.

Electrical Connections

- PV275 valves are designed for PC board mounting.
- 600LT valves are provided with .025" sq. pins that are .200" apart (lead wire adapter: Part Number IHWX0248020A). PC board mounting is also available.

LFV Series



The LFV Series is a family of 2-way isolation valves, featuring bi-directional flow and a contoured flow path which allows complete flushing. This contoured flow path also minimizes damage to “delicate” fluids. The small internal volume reduces the amount of fluid needed to fill the system (transport volume) further reducing sample and reagent requirements. LFV valves are optimized for applications in analytical instruments, biotechnology and IVD devices.

- Standard and Low Pressure Models Available
- 30 ms Response Time
- Operating Life of 10 Million Cycles Minimum
- Standard Operating Pressures up to 30 psid
(Higher Pressures Available as Custom Designs)
- Low Power Consumption
- 12 and 24 vdc Models
- Low Internal Volume
- Zero Dead Volume
- Multiple Porting Options
- Manifold Mountable



1/4-28 Port Style

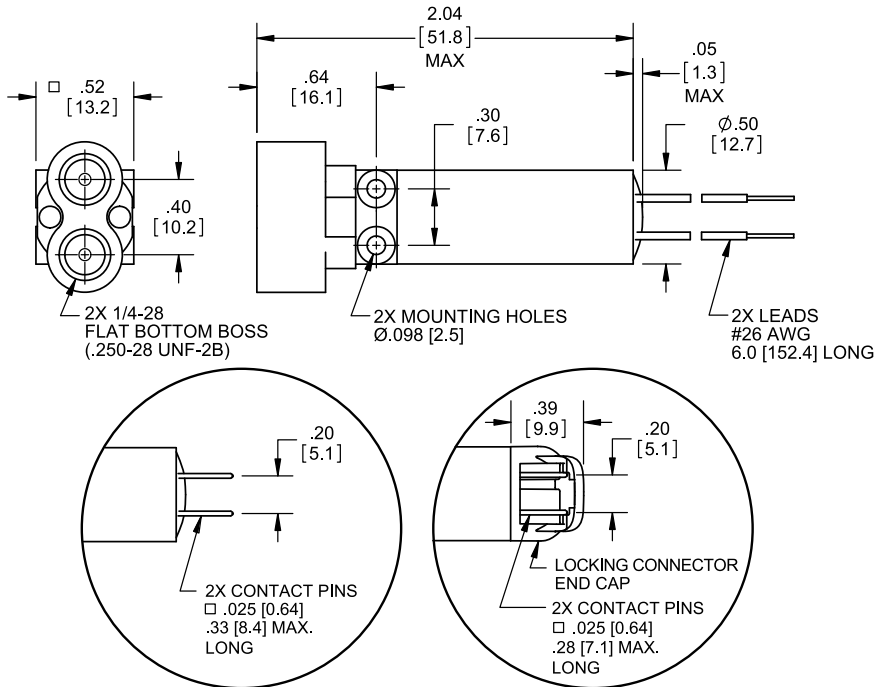

E

PART NUMBER 1	ELECTRICAL CONNECTION	OPERATING PRESSURE (psig)	POWER CONSUMPTION (W)
LFVA __ 30213H	Lead Wire	Vac - 30	1.5
LFVA __ 31213H	Pin	Vac - 30	1.5
LFVA __ 32213H	Pin with locking end cap	Vac - 30	1.5
LFVA __ 30113H	Lead Wire	Vac - 30	1.5
LFVA __ 31113H	Pin	Vac - 30	1.5
LFVA __ 32113H	Pin with locking end cap	Vac - 30	1.5
LFVA __ 30313H	Lead Wire	1 - 30	1.5
LFVA __ 31313H	Pin	1 - 30	1.5
LFVA __ 32313H	Pin with locking end cap	1 - 30	1.5
LFVA __ 30413H	Lead Wire	Vac - 20	1.5
LFVA __ 31413H	Pin	Vac - 20	1.5
LFVA __ 32413H	Pin with locking end cap	Vac - 20	1.5

NOTES: (1) Solenoid valves are available in 12 and 24 vdc configurations.

LFVA __ 30213H



Coil Voltage: 12 = 12 volts
24 = 24 volts

1/4-28 Port Style

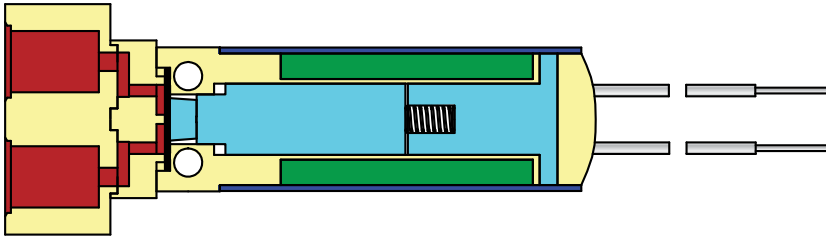

- Coil
- Housing
- Shield
- Armature/
Plunger Stop
- Seal
- Flow Path

Unless otherwise specified, dimensions are in inches [mm].

	LOHM RATE ² (Cv)	INTERNAL VOLUME (μ L)	WEIGHT (g)	WETTED MATERIALS ³
	1,300 (0.015)	43	25	EPDM / PEEK
	1,300 (0.015)	43	25	EPDM / PEEK
	1,300 (0.015)	43	25	EPDM / PEEK
	1,300 (0.015)	43	25	FKM / PEEK
	1,300 (0.015)	43	25	FKM / PEEK
	1,300 (0.015)	43	25	FKM / PEEK
	1,300 (0.015)	43	25	FFKM / PEEK
	1,300 (0.015)	43	25	FFKM / PEEK
	1,300 (0.015)	43	25	FFKM / PEEK
	1,300 (0.015)	43	25	FFKM / PEEK
	1,300 (0.015)	43	25	FFKM / PEEK
	1,300 (0.015)	43	25	FFKM / PEEK
	1,300 (0.015)	43	25	FFKM / PEEK

(2) Refer to Engineering Section, [page S3](#) for a full description of the Lohm Laws.

(3) Refer to Engineering Section, [pages S61-62](#) for material information and abbreviations.

062 MINSTAC Port Style

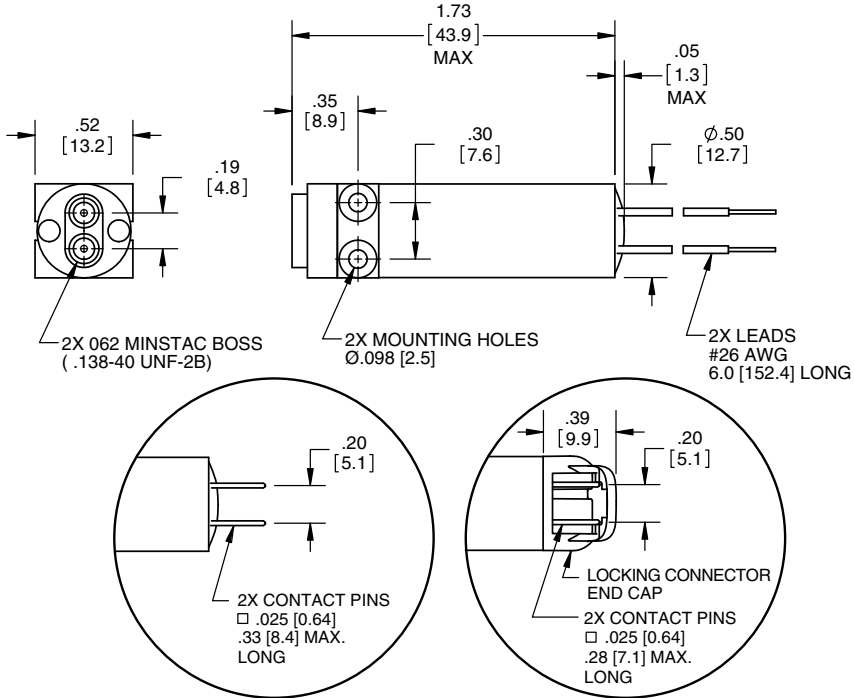

E

PART NUMBER ¹	ELECTRICAL CONNECTION	OPERATING PRESSURE (psig)	POWER CONSUMPTION (W)	
LFVA __ 10220H	Lead Wire	Vac - 30	1.5	
LFVA __ 11220H	Pin	Vac - 30	1.5	
LFVA __ 12220H	Pin with locking end cap	Vac - 30	1.5	
LFVA __ 10120H	Lead Wire	Vac - 30	1.5	
LFVA __ 11120H	Pin	Vac - 30	1.5	
LFVA __ 12120H	Pin with locking end cap	Vac -30	1.5	
LFVA __ 10320H	Lead Wire	1 - 30	1.5	
LFVA __ 11320H	Pin	1 - 30	1.5	
LFVA __ 12320H	Pin with locking end cap	1 - 30	1.5	
LFVA __ 10420H	Lead Wire	Vac - 20	1.5	
LFVA __ 11420H	Pin	Vac - 20	1.5	
LFVA __ 12420H	Pin with locking end cap	Vac - 20	1.5	

NOTES: (1) Solenoid valves are available in 12 and 24 vdc configurations.

LFVA __ 10220H

↑
Coil Voltage: 12 = 12 volts
24 = 24 volts

062 MINSTAC Port Style

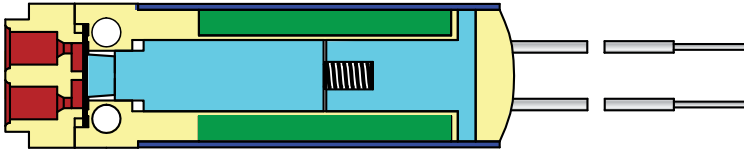

Unless otherwise specified, dimensions are in inches [mm].

	LOHM RATE ² (Cv)	INTERNAL VOLUME (μ L)	WEIGHT (g)	WETTED MATERIALS ³
	2,000 (0.010)	11	24	EPDM / PEEK
	2,000 (0.010)	11	24	EPDM / PEEK
	2,000 (0.010)	11	24	EPDM / PEEK
	2,000 (0.010)	11	24	FKM / PEEK
	2,000 (0.010)	11	24	FKM / PEEK
	2,000 (0.010)	11	24	FKM / PEEK
	2,000 (0.010)	11	24	FFKM / PEEK
	2,000 (0.010)	11	24	FFKM / PEEK
	2,000 (0.010)	11	24	FFKM / PEEK
	2,000 (0.010)	11	24	FFKM / PEEK
	2,000 (0.010)	11	24	FFKM / PEEK
	2,000 (0.010)	11	24	FFKM / PEEK

(2) Refer to Engineering Section, [page S3](#) for a full description of the Lohm Laws.

(3) Refer to Engineering Section, [pages S61-62](#) for material information and abbreviations.

Flange Style⁴

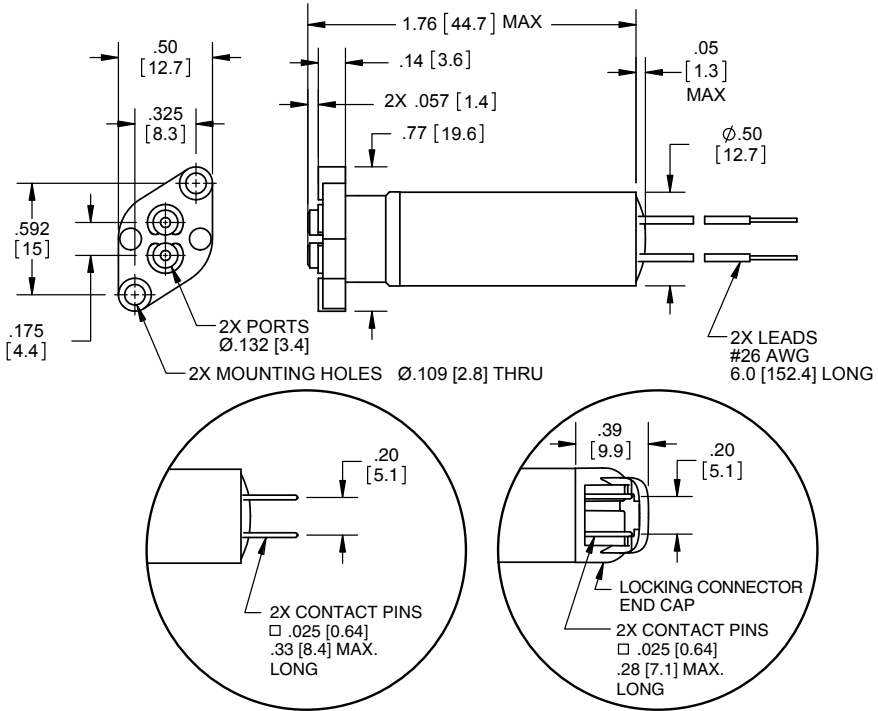

E

PART NUMBER ¹	ELECTRICAL CONNECTION	OPERATING PRESSURE (psig)	POWER CONSUMPTION (W)
LFVA __ 50210H	Lead Wire	Vac - 30	1.4
LFVA __ 51210H	Pin	Vac - 30	1.4
LFVA __ 52210H	Pin with locking end cap	Vac - 30	1.4
LFVA __ 50110H	Lead Wire	Vac - 30	1.4
LFVA __ 51110H	Pin	Vac - 30	1.4
LFVA __ 52110H	Pin with locking end cap	Vac - 30	1.4
LFVA __ 50310H	Lead Wire	1 - 30	1.4
LFVA __ 51310H	Pin	1 - 30	1.4
LFVA __ 52310H	Pin with locking end cap	1 - 30	1.4
LFVA __ 50410H	Lead Wire	Vac - 20	1.4
LFVA __ 51410H	Pin	Vac - 20	1.4
LFVA __ 52410H	Pin with locking end cap	Vac - 20	1.4

NOTES: (1) Solenoid valves are available in 12 and 24 vdc configurations.

LFVA __ 50210H



Coil Voltage: 12 = 12 volts
24 = 24 volts

Flange Style

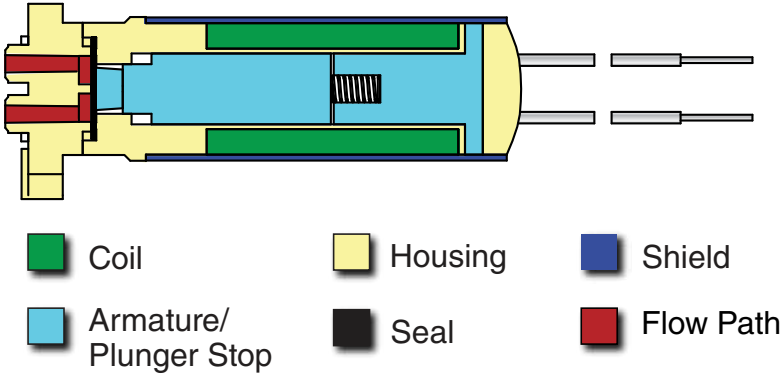

Unless otherwise specified, dimensions are in inches [mm].

	LOHM RATE ² (Cv)	INTERNAL VOLUME (μ L)	WEIGHT (g)	WETTED MATERIALS ³
	1,000 (0.020)	21	24	EPDM / PEEK
	1,000 (0.020)	21	24	EPDM / PEEK
	1,000 (0.020)	21	24	EPDM / PEEK
	1,000 (0.020)	21	24	FKM / PEEK
	1,000 (0.020)	21	24	FKM / PEEK
	1,000 (0.020)	21	24	FKM / PEEK
	1,000 (0.020)	21	24	FFKM / PEEK
	1,000 (0.020)	21	24	FFKM / PEEK
	1,000 (0.020)	21	24	FFKM / PEEK
	1,000 (0.020)	21	24	FFKM / PEEK
	1,000 (0.020)	21	24	FFKM / PEEK
	1,000 (0.020)	21	24	FFKM / PEEK

(2) Refer to Engineering Section, [page S3](#) for a full description of the Lohm Laws.

(3) Refer to Engineering Section, [pages S61-62](#) for material information and abbreviations.

(4) See [page E17](#) for mounting boss details.

Barbed Port Style

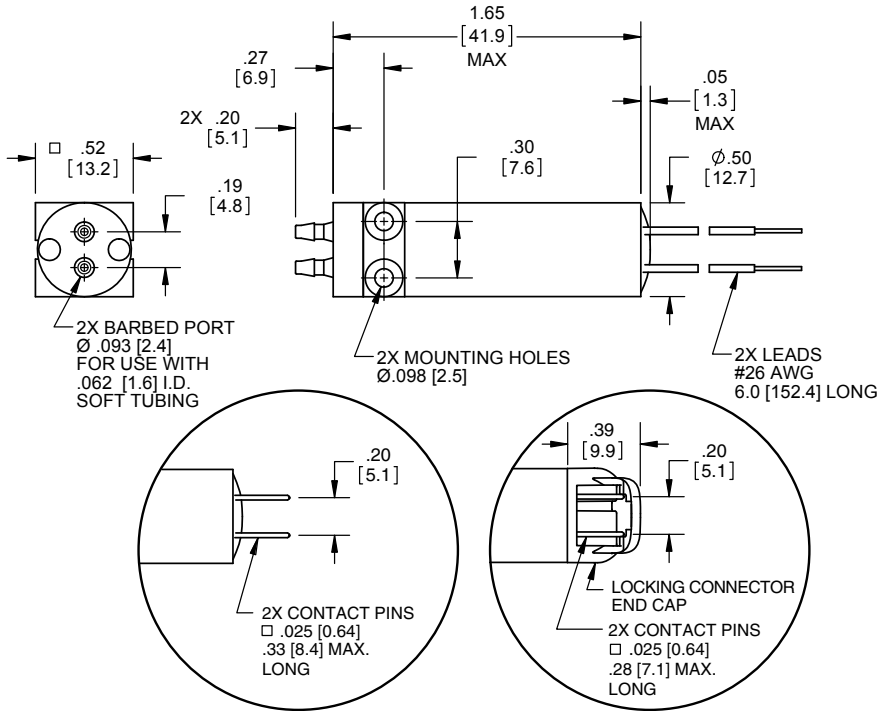

E

PART NUMBER 1	ELECTRICAL CONNECTION	OPERATING PRESSURE (psig)	POWER CONSUMPTION (W)
LFVA __ 20210H	Lead Wire	Vac - 30	1.5
LFVA __ 21210H	Pin	Vac - 30	1.5
LFVA __ 22210H	Pin with locking end cap	Vac - 30	1.5
LFVA __ 20110H	Lead Wire	Vac - 30	1.5
LFVA __ 21110H	Pin	Vac - 30	1.5
LFVA __ 22110H	Pin with locking end cap	Vac - 30	1.5
LFVA __ 20310H	Lead Wire	1 - 30	1.5
LFVA __ 21310H	Pin	1 - 30	1.5
LFVA __ 22310H	Pin with locking end cap	1 - 30	1.5
LFVA __ 20410H	Lead Wire	Vac - 20	1.5
LFVA __ 21410H	Pin	Vac - 20	1.5
LFVA __ 22410H	Pin with locking end cap	Vac - 20	1.5

NOTES: (1) Solenoid valves are available in 12 and 24 vdc configurations.

LFVA __ 20210H



Coil Voltage: 12 = 12 volts
24 = 24 volts

Barbed Port Style

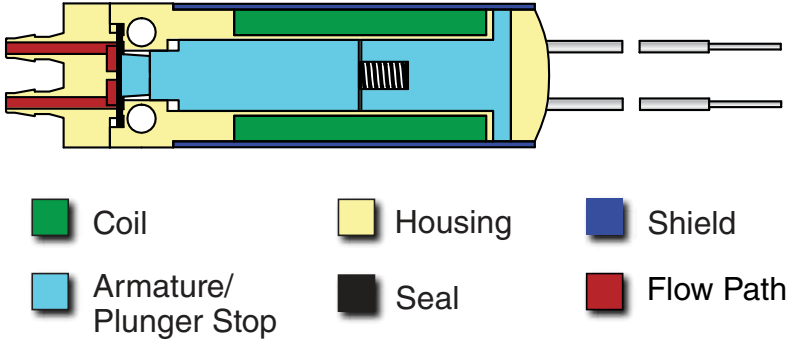

Unless otherwise specified, dimensions are in inches [mm].

	LOHM RATE ² (Cv)	INTERNAL VOLUME (μ L)	WEIGHT (g)	WETTED MATERIALS ³
	1,000 (0.020)	43	24	EPDM / PEEK
	1,000 (0.020)	43	24	EPDM / PEEK
	1,000 (0.020)	43	24	EPDM / PEEK
	1,000 (0.020)	43	24	FKM / PEEK
	1,000 (0.020)	43	24	FKM / PEEK
	1,000 (0.020)	43	24	FKM / PEEK
	1,000 (0.020)	43	24	FFKM / PEEK
	1,000 (0.020)	43	24	FFKM / PEEK
	1,000 (0.020)	43	24	FFKM / PEEK
	1,000 (0.020)	43	24	FFKM / PEEK
	1,000 (0.020)	43	24	FFKM / PEEK
	1,000 (0.020)	43	24	FFKM / PEEK

(2) Refer to Engineering Section, [page S3](#) for a full description of the Lohm Laws.

(3) Refer to Engineering Section, [pages S61-62](#) for material information and abbreviations.

Coupling Screw Style ⁴

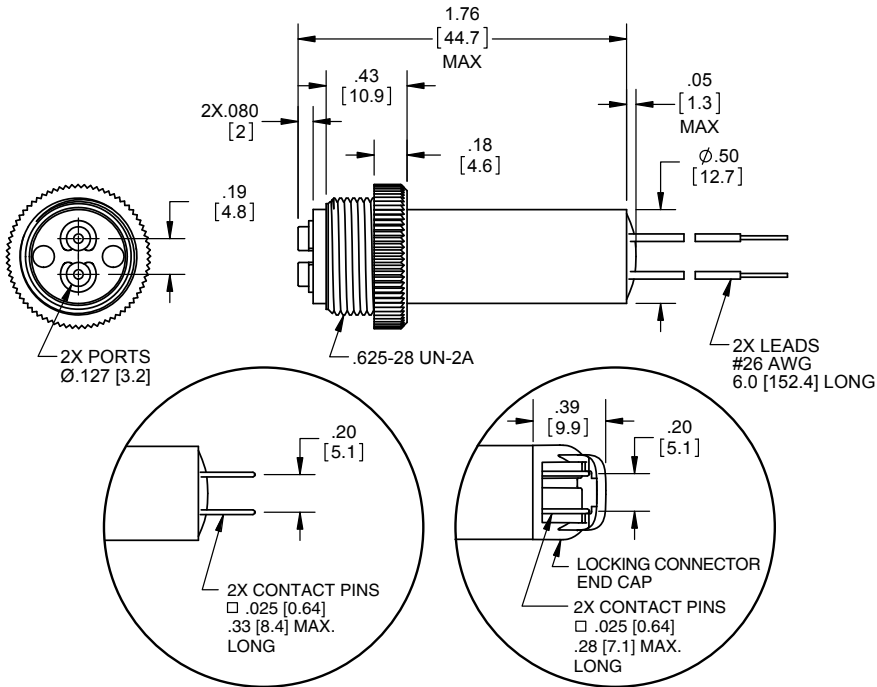

PART NUMBER ¹	ELECTRICAL CONNECTION	OPERATING PRESSURE (psig)	POWER CONSUMPTION (W)	
LFVA __ 40120H	Lead Wire	Vac - 30	1.5	
LFVA __ 41220H	Pin	Vac - 30	1.5	
LFVA __ 42220H	Pin with locking end cap	Vac - 30	1.5	
LFVA __ 40120H	Lead Wire	Vac - 30	1.5	
LFVA __ 41120H	Pin	Vac - 30	1.5	
LFVA __ 42120H	Pin with locking end cap	Vac - 30	1.5	
LFVA __ 40320H	Lead Wire	1 - 30	1.5	
LFVA __ 41320H	Pin	1 - 30	1.5	
LFVA __ 42320H	Pin with locking end cap	1 - 30	1.5	
LFVA __ 40420H	Lead Wire	Vac - 20	1.5	
LFVA __ 41420H	Pin	Vac - 20	1.5	
LFVA __ 42420H	Pin with locking end cap	Vac - 20	1.5	

NOTES: (1) Solenoid valves are available in 12 and 24 vdc configurations.

LFVA __ 40120H



Coil Voltage: 12 = 12 volts
24 = 24 volts

Coupling Screw Style

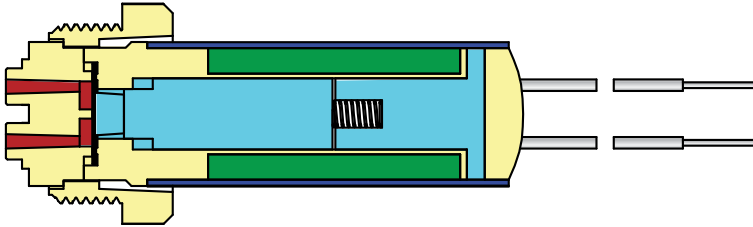

Unless otherwise specified, dimensions are in inches [mm].

E

	LOHM RATE ² (Cv)	INTERNAL VOLUME (μ L)	WEIGHT (g)	WETTED MATERIALS ³
	2,000 (0.010)	21	26	EPDM / PEEK
	2,000 (0.010)	21	26	EPDM / PEEK
	2,000 (0.010)	21	26	EPDM / PEEK
	2,000 (0.010)	21	26	FKM / PEEK
	2,000 (0.010)	21	26	FKM / PEEK
	2,000 (0.010)	21	26	FKM / PEEK
	2,000 (0.010)	21	26	FFKM / PEEK
	2,000 (0.010)	21	26	FFKM / PEEK
	2,000 (0.010)	21	26	FFKM / PEEK
	2,000 (0.010)	21	26	FFKM / PEEK
	2,000 (0.010)	21	26	FFKM / PEEK
	2,000 (0.010)	21	26	FFKM / PEEK

(2) Refer to Engineering Section, [page S3](#) for a full description of the Lohm Laws.

(3) Refer to Engineering Section, [pages S61-62](#) for material information and abbreviations.

(4) See [page E17](#) for mounting boss details.

Standard Manifolds

STYLE	PART NUMBER		DESCRIPTION	LENGTH "A"
	PEEK	PMMA		
Coupling Screw	LSMX0517010B	LSMX0517020B	1 valve	1.00" (25.4 mm)
	LFMX0514100B	LFMX0514300B	3 valve	3.25" (82.6 mm)
	LFMX0514200B	LFMX0514400B	8 valve	8.25" (209.6 mm)
Flange	N/A	LSMX0502400B	1 valve	1.00" (25.4 mm)
	LSMX0503600B	LSMX0502360B	2 valve	1.22" (31.0 mm)
	LSMX0503610B	LSMX0502370B	3 valve	1.73" (43.9 mm)
	LSMX0503620B	LSMX0502380B	4 valve	2.24" (56.9 mm)
	LSMX0503630B	LSMX0502390B	5 valve	2.75" (69.9 mm)

NOTES: (1) Part Numbers are for the manifold only. Valves sold separately.

Refer to Manifold Technology ([Section K](#)) for custom design capabilities.

E

Manifold Accessories

STYLE	PART NUMBER	DESCRIPTION
Flange Mount	LSWX0208050A	Standard Gasket (FFKM)
Coupling Screw	LHWX0208750A	Standard Gasket (FFKM)

Coupling Screw Style

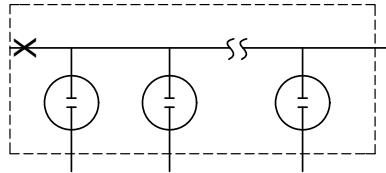
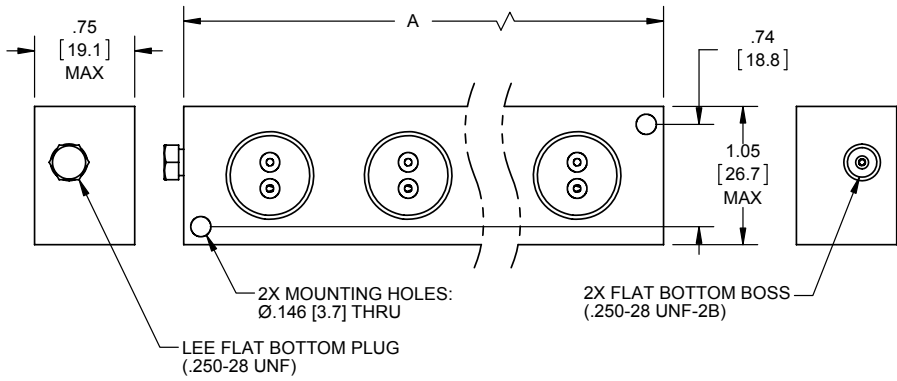

FLOW SCHEMATIC

Flange Style

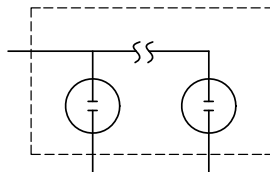
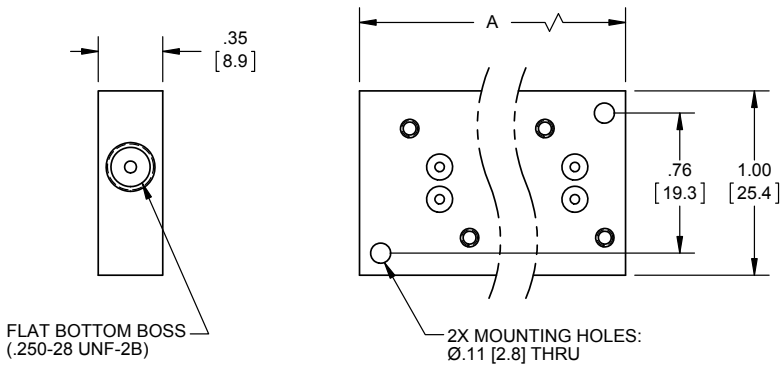

FLOW SCHEMATIC

Unless otherwise specified, dimensions are in inches [mm].



GENERAL SPECIFICATIONS

The following specifications apply to all LFV Series valves, unless otherwise noted.

Life Expectancy

The valves will typically operate for a minimum of 10 million cycles on water.

Operating Pressure

- The valves will operate within the normal pressure range when supplied with the rated voltage +/- 5%.

Valve Proof Pressure: 2x normal operating pressure

Valve Burst Pressure: 3x normal operating pressure

Operating Temperature

- As the ambient temperature decreases, the valve's response time will increase. Contact The Lee Company for lower temperature applications.
- Maximum solenoid coil temperature is 220°F (104°C)
- Increasing the operating temperature tends to limit coil performance. The valve duty cycle and energized time must be evaluated for conformance with the maximum recommended operating and coil temperatures.
- Minimum and maximum ambient operating temperatures are dependent on the elastomer selection. Lower temperatures will increase the response time needed. If the temperature is too low, the valves may fail to open (ref. chart below for temperature ranges of the 3 elastomers). For applications with temperatures below those listed, please contact The Lee Company.

MATERIAL	MINIMUM	MAXIMUM
EPDM	30°F (1°C)	120°F (49°C)
FKM	40°F (4°C)	120°F (49°C)
FFKM	70°F (21°C)	120°F (49°C)

Response Time

- Typical response time is 30 ms maximum at 68°F (20°C), 2 Hz, air at 10 psig.
- Response times can be enhanced with the use of high speed drive circuits. Refer to Engineering Section, [page S38](#).

Filtration

Filtration of 35 microns or finer is recommended.

Electrical Connections

The LFV coils are not polarized and therefore can be connected to the power in either direction. There are three different styles of electrical connections:

- **Lead wires:** Valves are supplied with 6", #26 AWG lead wires. The ends are stripped and tinned. Electrical connectors can be added as specials.
- **Pins:** Valves are supplied with two 0.025" square electrical pins. The pins are spaced 0.20" apart and will work with standard electrical connectors designed for 0.10" spacing.
- **Pins with Locking End Caps:** These are similar to pins, but a secondary retention clip has been added. These will work with AMP 104257-2 style connectors. The Lee Company offers compatible lead wire sets in two different lengths:
 - 6" lead wire set: Part Number LSWX0504300A
 - 24" lead wire set: Part Number LSWX0606700A

Electrical Characteristics

- Standard operating voltages are 12 and 24 vdc $\pm 5\%$.
- For power consumption, see valve selection charts on [pages E3-12](#).
- Holding voltage is 50% of operating voltage.
- Refer to Engineering Section, [pages S36-43](#) for special drive circuits.

Port Connections

Several different port (fluid) connections are available.

- **Tube Valves:** Mount valves using #2 (2 mm) mounting screws. 0.052" of screw length is required in addition to the length of the thread on the mounting plate. Screws should be torqued to a maximum of 15 in-oz.
- **Manifold Mounted Valves (flange mount style):** Mount valves using two #2 (2 mm) mounting screws. Screws should be evenly torqued to 15 in-oz max. See [page E17](#) for manifold mounting details.
- **Manifold Mounted Valves (coupling screw style):** The coupling screw should be tightened to 60-120 in-oz. See [page E17](#) for manifold mounting details.

VALVE MANIFOLD MOUNTING DETAILS

Flange Mount Boss

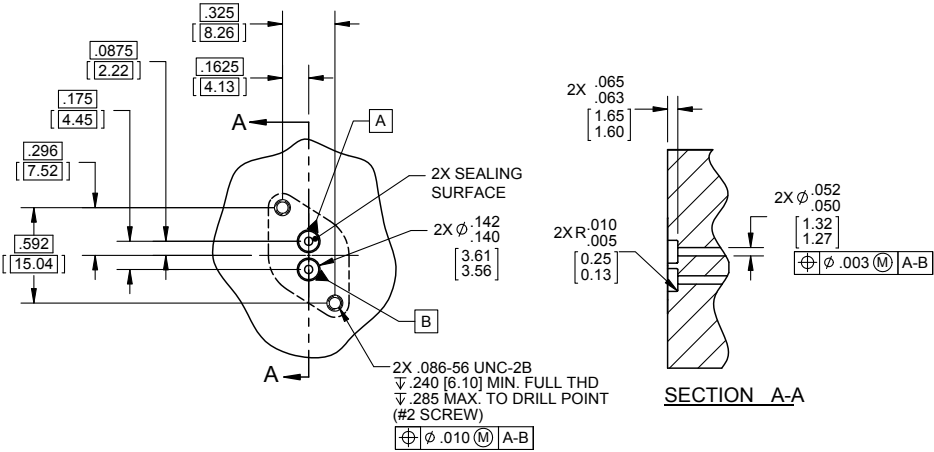

Reference Drawing Number LSIX1001100A

Coupling Screw Boss

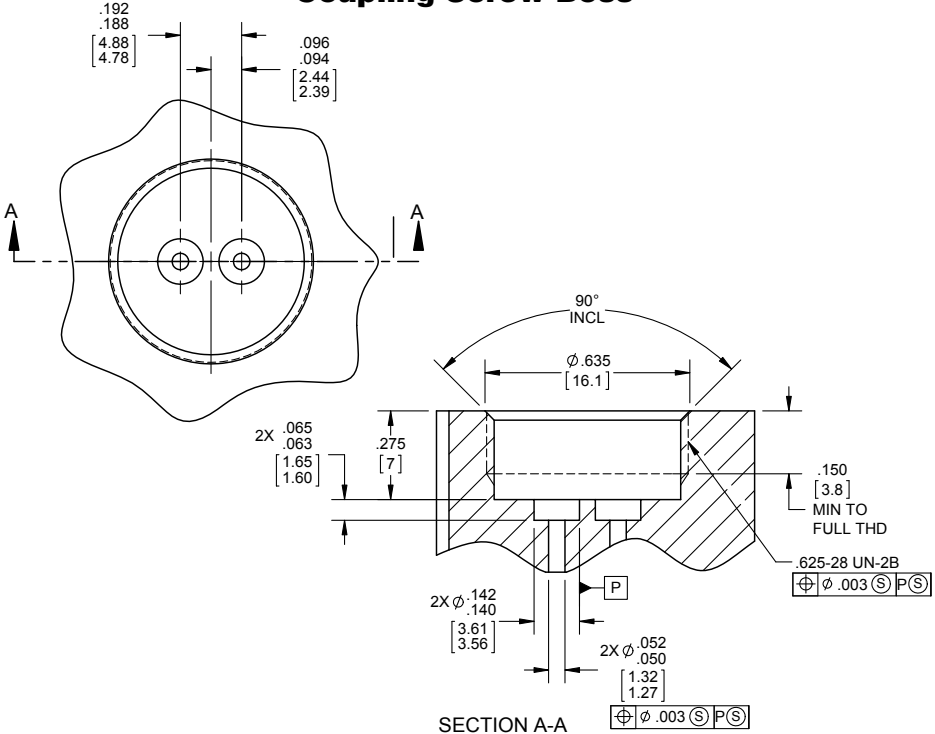

Reference Drawing Number LSIX1000850A

Unless otherwise specified, dimensions are in inches [mm].



FLOW vs PRESSURE

Typical Water Flow Characteristics (LFV Series Valves)

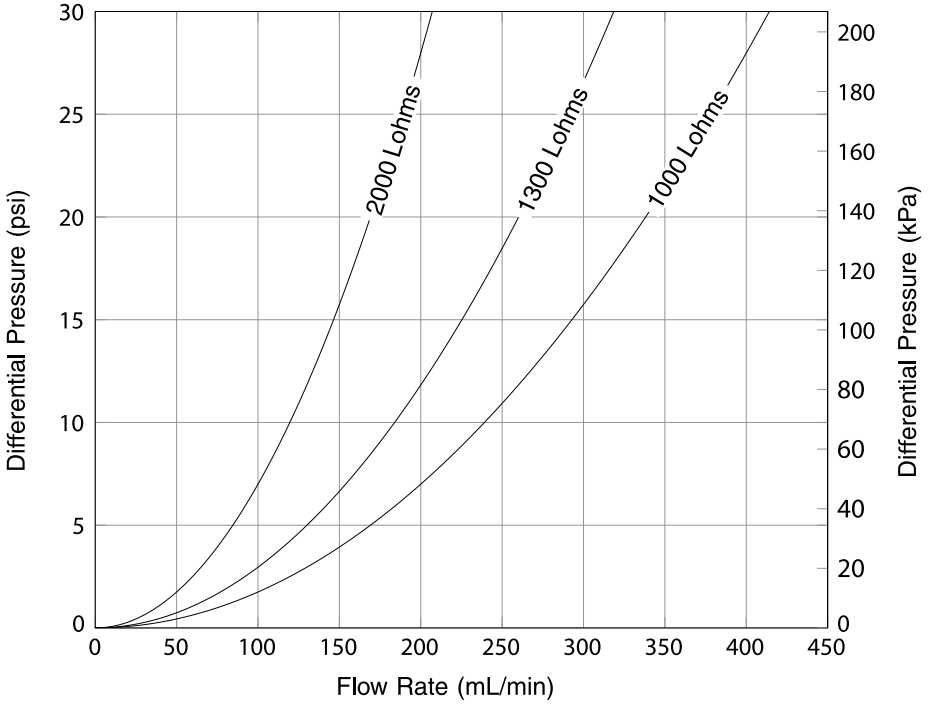

LFR Series



The LFR Series Micro Inert Valves (MIV) are 3-way inert solenoid valves designed for applications demanding high flow and small size. The different mounting combinations and porting options allow the designer the highest degree of freedom available.

- As Low as 700 Lohms
- Pressure Range: 28 in. Hg Vac - 30 psig
- 30 ms Response Time
- 10 Million Cycles Minimum
- Power Consumption: 1.6 Watts
- 12 and 24 Volt Models
- Available with EPDM, FKM, or FFKM Diaphragm
- PEEK Porthead on all Models
- Manifold Mount, Barbed, and 1/4-28 Flat Bottom Boss Available



Barbed Port Style

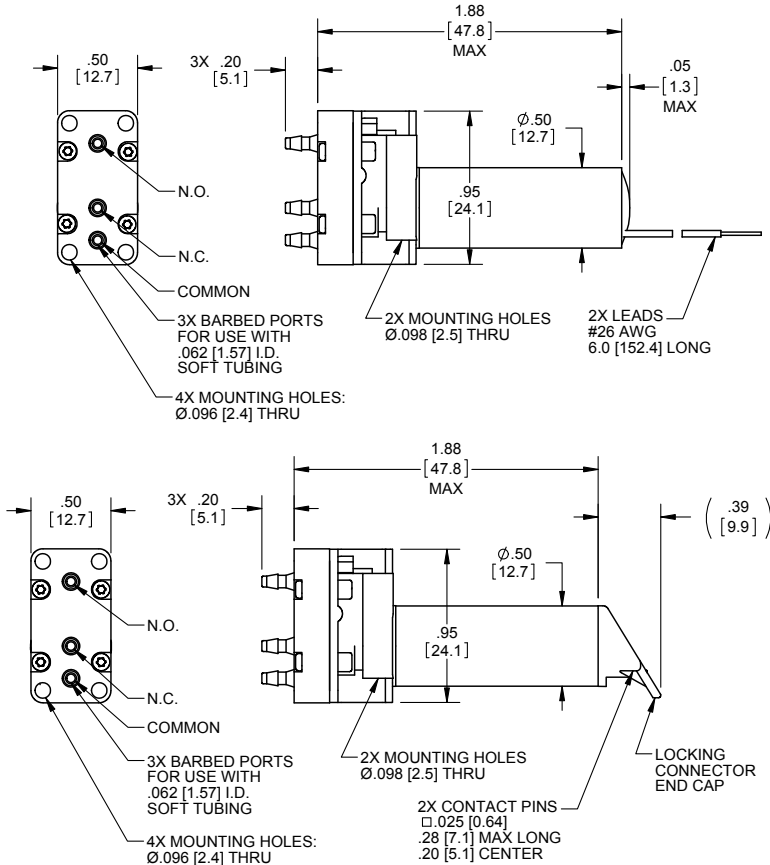

F

PART NUMBER ¹	ELECTRICAL CONNECTION	OPERATING PRESSURE (psig)	POWER CONSUMPTION ⁴ (W)
LFRA__20270D	Lead Wire	28 in. Hg Vac - 30	1.6
LFRA__22270D	Pin w/ Locking End Cap	28 in. Hg Vac - 30	1.6
LFRA__20170D	Lead Wire	28 in. Hg Vac - 30	1.6
LFRA__22170D	Pin w/ Locking End Cap	28 in. Hg Vac - 30	1.6
LFRA__20370D	Lead Wire	28 in. Hg Vac - 30	1.6
LFRA__22370D	Pin w/ Locking End Cap	28 in. Hg Vac - 30	1.6

NOTES: (1) Solenoid valves are available in 12 and 24 vdc configurations.

LFRA__20270D

↑
Coil Voltage: 12 = 12 volts
24 = 24 volts

Barbed Port Style

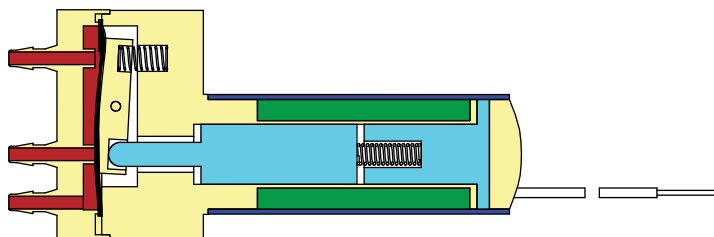

Unless otherwise specified, dimensions are in inches [mm].

	LOHM RATE ² (Cv)	INTERNAL VOLUME (μ L)	WEIGHT (g)	WETTED MATERIALS ³
	700 (0.029)	150	27	EPDM/PEEK
	700 (0.029)	150	27	EPDM/PEEK
	700 (0.029)	150	27	FKM/PEEK
	700 (0.029)	150	27	FKM/PEEK
	700 (0.029)	150	27	FFKM/PEEK
	700 (0.029)	150	27	FFKM/PEEK

F

(2) Refer to Engineering Section, [page S3](#) for a full description of the Lohm Laws.
 (3) Refer to Engineering Section, [pages S61-62](#) for material information and abbreviations.
 (4) See [page F14](#) for complete electrical characteristics.

1/4-28 Port Style

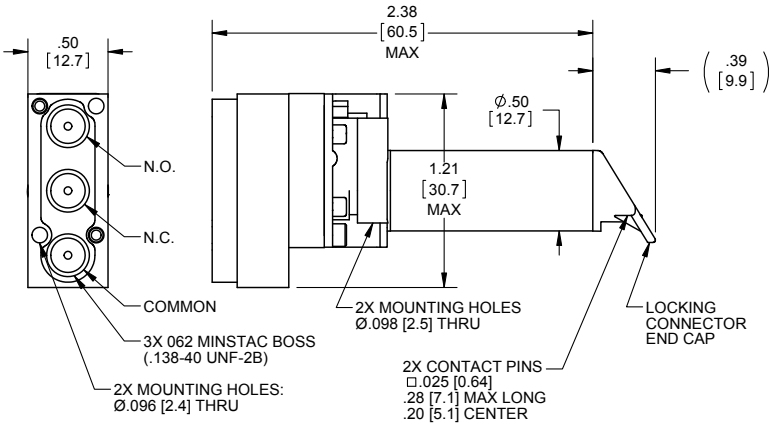
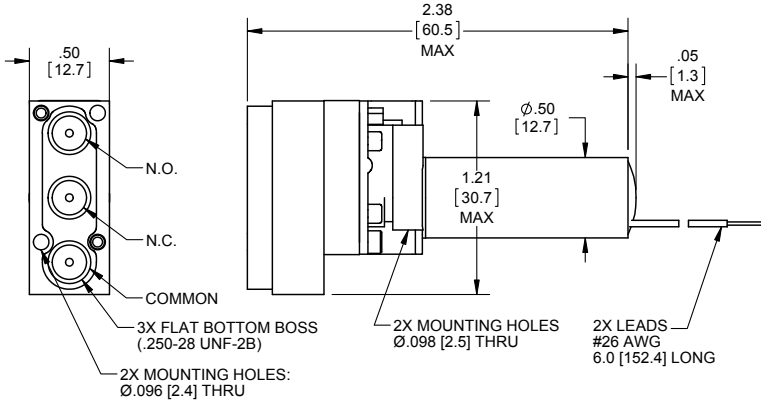

F

PART NUMBER ¹	ELECTRICAL CONNECTION	OPERATING PRESSURE (psig)	POWER CONSUMPTION ⁴ (W)
LFRA__30210H	Lead Wire	28 in. Hg Vac - 30	1.6
LFRA__32210H	Pin w/ Locking End Cap	28 in. Hg Vac - 30	1.6
LFRA__30110H	Lead Wire	28 in. Hg Vac - 30	1.6
LFRA__32110H	Pin w/ Locking End Cap	28 in. Hg Vac - 30	1.6
LFRA__30310H	Lead Wire	28 in. Hg Vac - 30	1.6
LFRA__32310H	Pin w/ Locking End Cap	28 in. Hg Vac - 30	1.6

NOTES: (1) Solenoid valves are available in 12 and 24 vdc configurations.

LFRA__30210H

↑
Coil Voltage: 12 = 12 volts
24 = 24 volts

1/4-28 Port Style

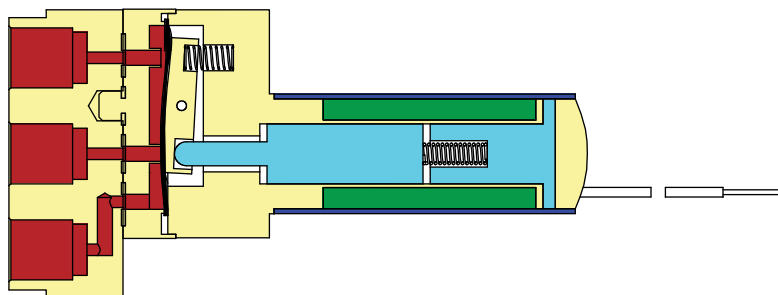

Unless otherwise specified, dimensions are in inches [mm].

	LOHM RATE ² (Cv)	INTERNAL VOLUME (μ L)	WEIGHT (g)	WETTED MATERIALS ³
	1000 (0.020)	180	31	EPDM/PEEK
	1000 (0.020)	180	31	EPDM/PEEK
	1000 (0.020)	180	31	FKM/PEEK
	1000 (0.020)	180	31	FKM/PEEK
	1000 (0.020)	180	31	FFKM/PEEK
	1000 (0.020)	180	31	FFKM/PEEK

(2) Refer to Engineering Section, [page S3](#) for a full description of the Lohm Laws.

(3) Refer to Engineering Section, [pages S61-62](#) for material information and abbreviations.

(4) See [page F14](#) for complete electrical characteristics.

062 MINSTAC Style

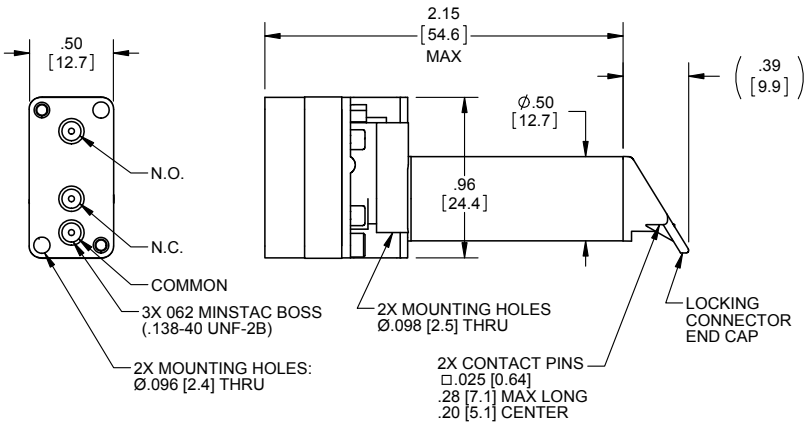
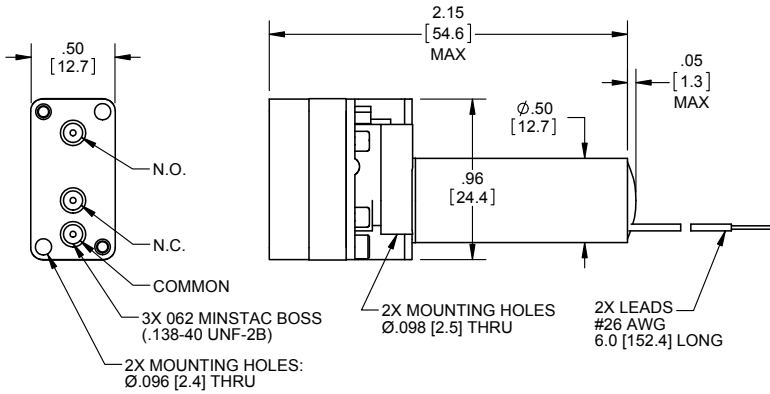

F

PART NUMBER ¹	ELECTRICAL CONNECTION	OPERATING PRESSURE (psig)	POWER CONSUMPTION ⁴ (W)
LFRA __ 10110H	Lead Wire	Vac - 30	1.6
LFRA __ 12110H	Pin w/ Locking End Cap	Vac - 30	1.6
LFRA __ 10210H	Lead Wire	Vac - 30	1.6
LFRA __ 12210H	Pin w/ Locking End Cap	Vac - 30	1.6
LFRA __ 10310H	Lead Wire	Vac - 30	1.6
LFRA __ 12310H	Pin w/ Locking End Cap	Vac - 30	1.6

NOTES: (1) Solenoid valves are available in 12 and 24 vdc configurations.

LFRA__10110H

Coil Voltage: 12 = 12 volts
 24 = 24 volts

062 MINSTAC Style

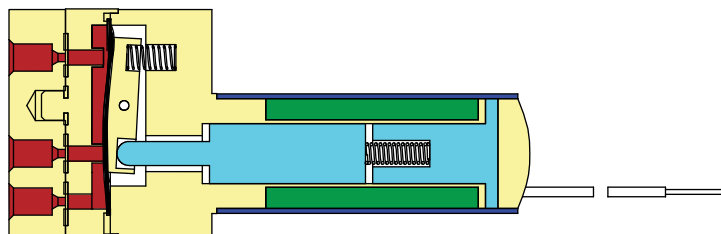

Unless otherwise specified, dimensions are in inches [mm].

	LOHM RATE ² (Cv)	INTERNAL VOLUME (μ L)	WEIGHT (g)	WETTED MATERIALS ³
	1100 (0.018)	151	31	FKM / PEEK
	1100 (0.018)	151	31	FKM / PEEK
	1100 (0.018)	151	31	EPDM / PEEK
	1100 (0.018)	151	31	EPDM / PEEK
	1100 (0.018)	151	31	FFKM / PEEK
	1100 (0.018)	151	31	FFKM / PEEK

F

(2) Refer to Engineering Section, [page S3](#) for a full description of the Lohm Laws.
 (3) Refer to Engineering Section, [pages S61-62](#) for material information and abbreviations.
 (4) See [page F14](#) for complete electrical characteristics.

Manifold Mount Style

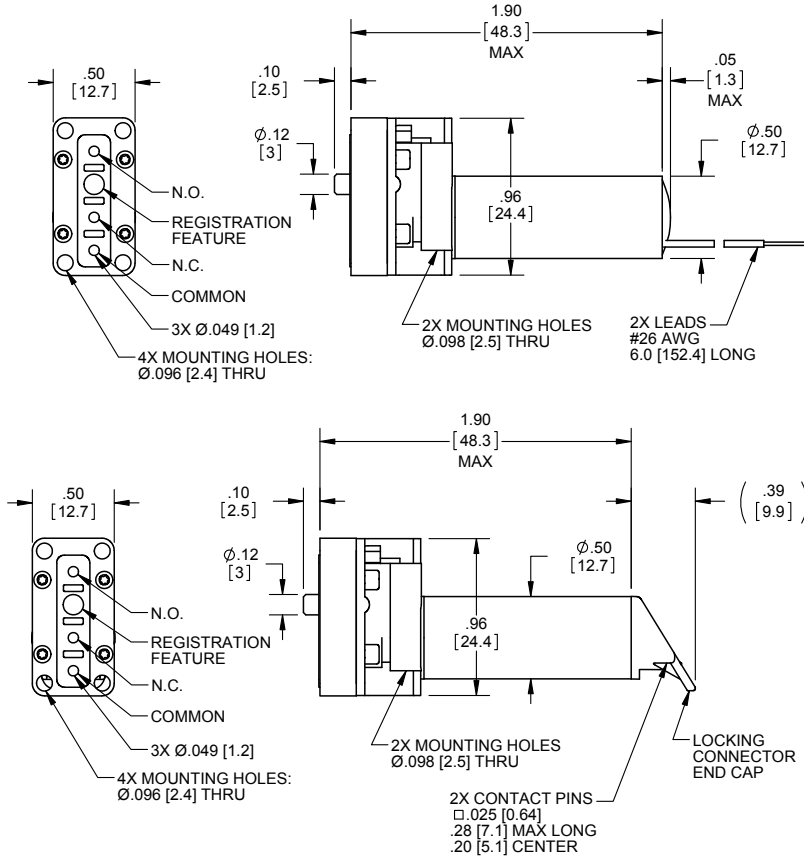

F

PART NUMBER ¹	ELECTRICAL CONNECTION	OPERATING PRESSURE (psig)	POWER CONSUMPTION ⁴ (W)	
LFRA __ 50270D	Lead Wire	28 in. Hg Vac - 30	1.6	
LFRA __ 52270D	Pin w/ Locking End Cap	28 in. Hg Vac - 30	1.6	
LFRA __ 50170D	Lead Wire	28 in. Hg Vac - 30	1.6	
LFRA __ 52170D	Pin w/ Locking End Cap	28 in. Hg Vac - 30	1.6	
LFRA __ 50370D	Lead Wire	28 in. Hg Vac - 30	1.6	
LFRA __ 52370D	Pin w/ Locking End Cap	28 in. Hg Vac - 30	1.6	

NOTES: (1) Solenoid valves are available in 12 and 24 vdc configurations.

LFRA__50270D

↑
Coil Voltage: 12 = 12 volts
24 = 24 volts

Manifold Mount Style

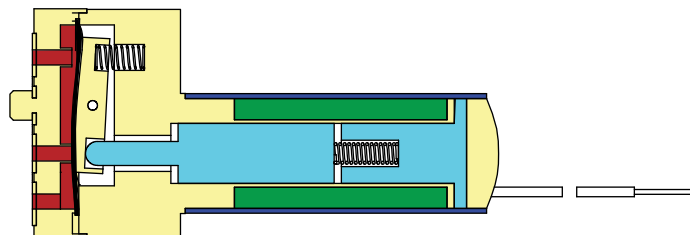

Unless otherwise specified, dimensions are in inches [mm].

F

	LOHM RATE ² (Cv)	INTERNAL VOLUME (μ L)	WEIGHT (g)	WETTED MATERIALS ³
	700 (0.029)	130	27	EPDM/PEEK
	700 (0.029)	130	27	EPDM/PEEK
	700 (0.029)	130	27	FKM/PEEK
	700 (0.029)	130	27	FKM/PEEK
	700 (0.029)	130	27	FFKM/PEEK
	700 (0.029)	130	27	FFKM/PEEK

(2) Refer to Engineering Section, [page S3](#) for a full description of the Lohm Laws.

(3) Refer to Engineering Section, [pages S61-62](#) for material information and abbreviations.

(4) See [page F14](#) for complete electrical characteristics.

Standard Manifolds

DESCRIPTION	PART NUMBER ¹ (PMMA)	PART NUMBER ¹ (PEEK)	LENGTH "A"	LENGTH "B"
2 valve	LSMX0501402C	LSMX0501412C	1.9" (48.26 mm)	1.66" (42.16 mm)
3 valve	LSMX0501403C	LSMX0501413C	2.45" (62.23 mm)	2.210" (56.13 mm)
4 valve	LSMX0501404C	LSMX0501414C	3.00" (76.20 mm)	2.760" (70.10 mm)
5 valve	LSMX0501405C	LSMX0501415C	3.55" (84.07 mm)	3.31" (84.07 mm)
6 valve	LSMX0501406C	LSMX0501416C	4.1" (104.10 mm)	3.86" (98.04 mm)

NOTES: (1) Part Numbers are for the manifold only. Valves sold separately. Standard manifolds are available in PEEK & PMMA. These contain 1/4-28 flat bottom connections and incorporate a common header and individual N.C. and N.O. ports for each valve.

Refer to Manifold Technology ([Section K](#)) for custom design capabilities.

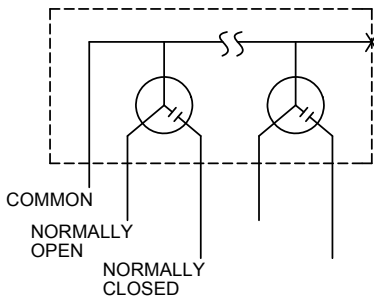

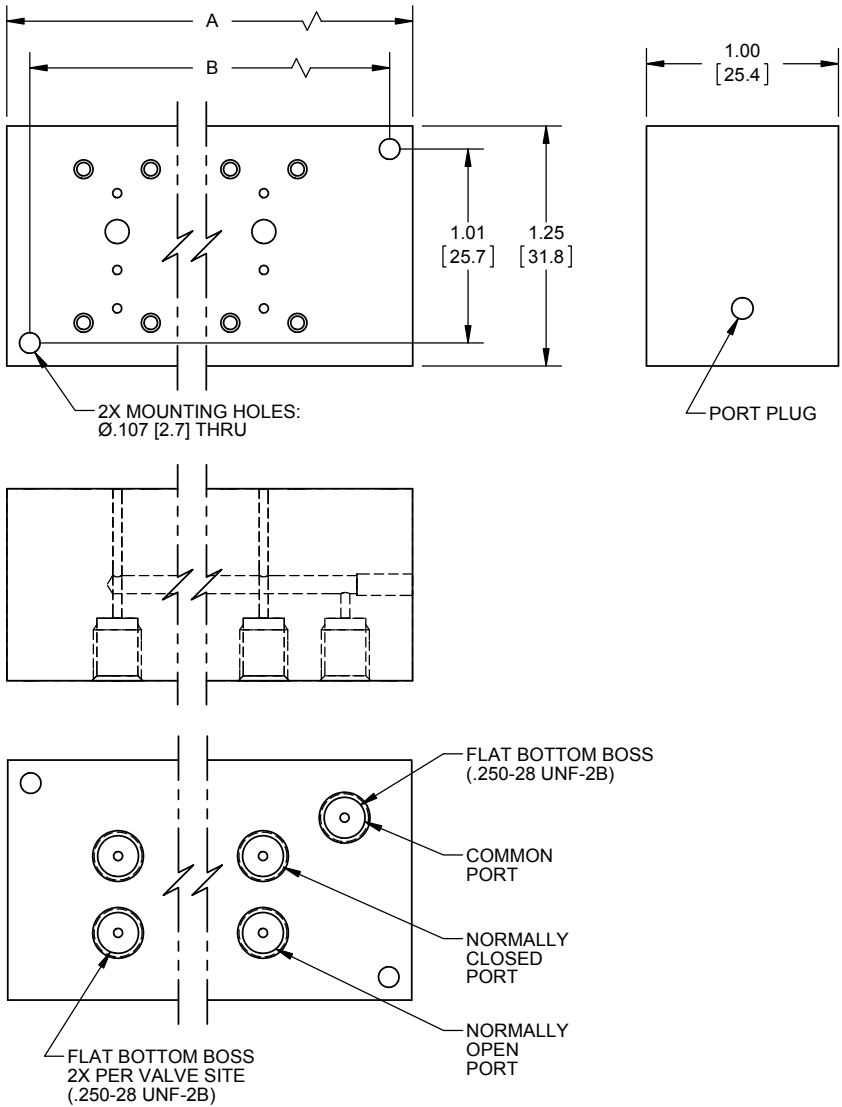

Unless otherwise specified, dimensions are in inches [mm].

GENERAL SPECIFICATIONS

The following specifications apply to all LFR Series valves, unless otherwise noted.

Life Expectancy

The valves will typically operate for a minimum of 10 million cycles on water.

Operating Pressure

The valves will operate within the normal pressure range when supplied with the rated voltage (+/- 5%).

Valve Proof Pressure: 2x normal operating pressure

Valve Burst Pressure: 3x normal operating pressure

Operating Temperature

- Maximum allowable solenoid temperature is 200°F (90°C)
- Increasing the operating temperature tends to limit the coil performance.
- The valve duty cycle must be evaluated to prevent the coil temperature from exceeding 200°F (90°C).
- Storage temperature is -20°F to 180°F (-28° to 80°C)
- Minimum and maximum ambient operating temperatures are dependent on the elastomer selection. Lower temperatures will increase the response time needed. If the temperature is too low, the valves may fail to open (ref. chart below for temperatures ranges of the 3 elastomers). For applications with temperatures below those listed, please contact The Lee Company.

MATERIAL	MINIMUM	MAXIMUM
EPDM	30°F (1°C)	120°F (49°C)
FKM	45°F (7°C)	120°F (49°C)
FFKM	70°F (21°C)	120°F (49°C)

Response Time

- Typical response time is 30 ms maximum at 68°F (20°C), 2Hz air at 10 psig.
- Response times can be enhanced with the use of high speed drive circuits. Refer to Engineering Section, [page S37](#).
- Lower temperatures will decrease response time (dependent on type of elastomer used in diaphragm).

Filtration

Filtration of 35 microns or finer is recommended.

Port Connections

Several different port (fluid) connections are available.

- *Barbed*: Ports designed for use with 1/16" I.D. flexible tubing
- *1/4-28*: Ports designed for standard 1/4-28 flat bottom fittings
- *Manifold Mount*: See [page F15](#) for manifold mounting details.

Valve Mounting

1/4-28 and Barbed Port Valves: Mount valves using #2 (2 mm) screws allowing 0.52" (12.7 mm) of screw length for valve thickness. Torque screws to 15 in-oz max.

Manifold Mount Valves

Minimum center to center spacing is 0.5" (12.7 mm). One gasket per valve is required for mounting (Part Number LHWX0218130A for FKM, LHWX0218140A for EPDM and LSWX0508210A for FFKM.) Each valve requires four #2 (M2) screws for mounting. Screws should be torqued to 13.5-16.5 in-oz (0.095-0.117 N-m).

Electrical Connections

The LFR coils are not polarized and therefore can be connected to the power in either direction. There are three different styles of electrical connections.

- *Lead wires*: Valves are supplied with 6", #26 AWG lead wires. The ends are stripped and tinned. Electrical connectors can be added as specials.
- *Pins*: Valves are supplied with two 0.025" square electrical pins. These pins are spaced 0.20" apart and will work with standard electrical connectors designed for 0.10" spacing.
- *Pins with Locking End Caps*: These are similar to pins, but a secondary retention clip has been added. These will work with AMP 104257-2 style connectors. The Lee Company offers compatible lead wire sets in two different lengths:
 - 6" lead wire set: Part Number LSWX0504300A
 - 24" lead wire set: Part Number LSWX0606700A

Electrical Characteristics

RATED VOLTAGE (vdc)	RESISTANCE (ohms)	INDUCTANCE CLOSED (mH)
12	91	930
24	360	217

- Holding voltage is 50% of operating voltage.

VALVE MOUNTING DETAILS

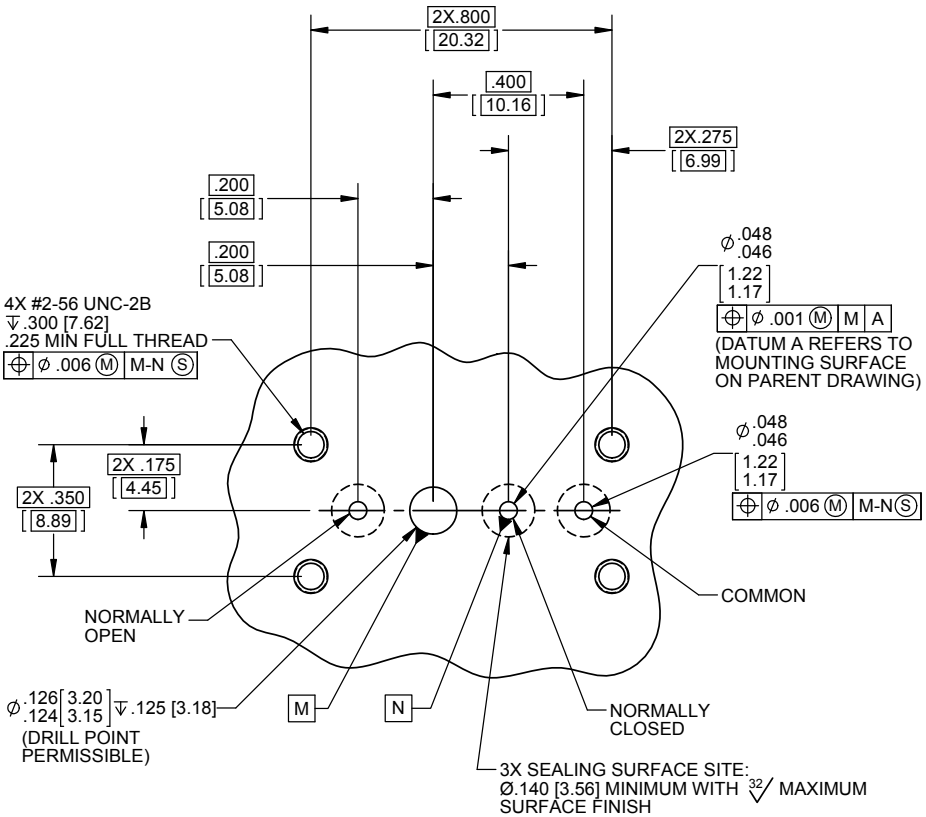

Boss Drawing: LSIX1001600A

Unless otherwise specified, dimensions are in inches [mm].

GENERAL ACCESSORIES/REPLACEMENT PARTS

PART NUMBER	DESCRIPTION
LHWX0213420A	Mounting Screws, #2 (or 2 mm), 0.438" long
LHWX0218130A	Standard Gasket, FKM
LHWX0218140A	Standard Gasket, EPDM
LSWX0508210A	Standard Gasket, FFKM

GRAPH OF FLOW VS PRESSURE FOR LFR VALVES

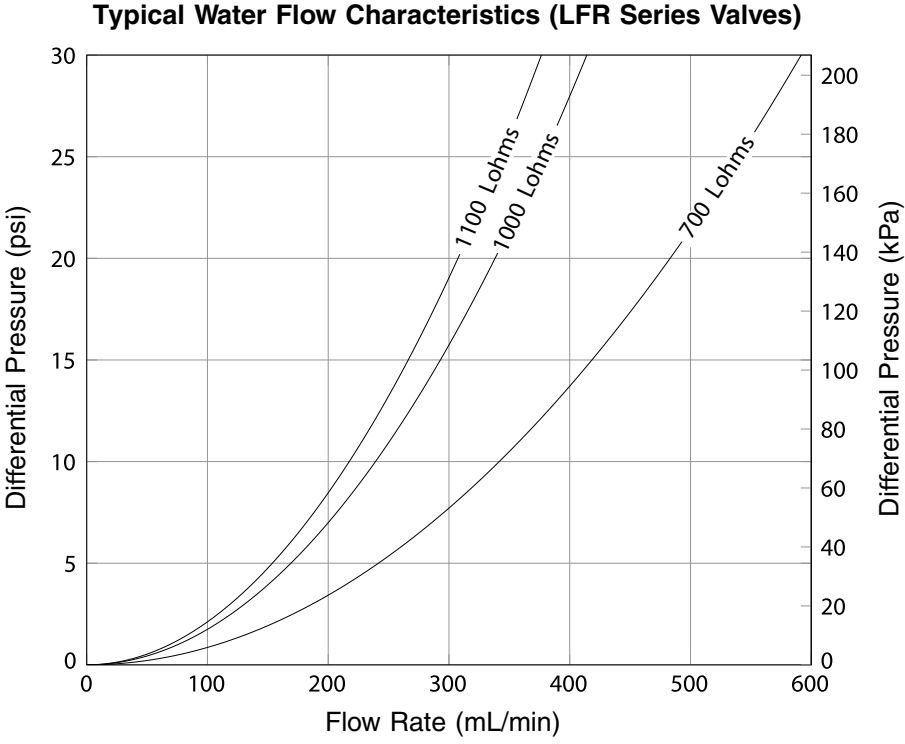

LFN Series

**G**

The LFN Series Solenoid Valves are 2-way normally closed, diaphragm valves, designed to provide consistent reliable switching in the smallest footprint possible. The small footprint allows a high valve packing density on manifolds. Combining this with the valves' low internal volume greatly reduces the overall system fluid volume and manifold size. The isolation diaphragm on an inert housing makes these valves suitable for the control of critical and aggressive fluids.

LFN valves feature:

- Small size: 0.3" center to center mounting
- Low internal volume: 13 microliters
- Fast response time: 20 ms (faster with a spike and hold circuit)
- Operating pressure: 30 psig
- Low Power: 900 mW

LFN SERIES SOLENOID VALVES

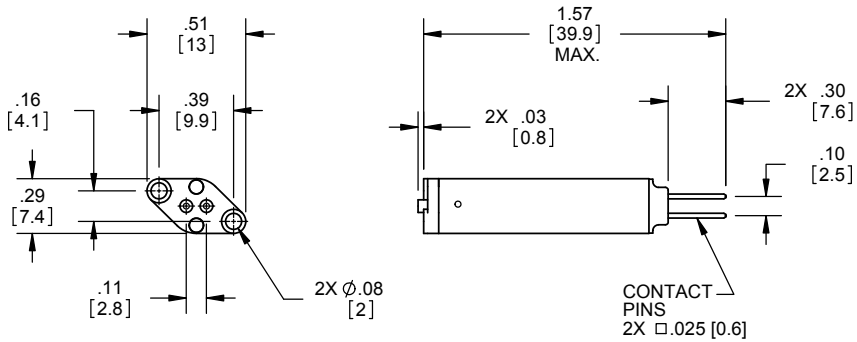

Unless otherwise specified, dimensions are in inches [mm].

PART NUMBER	VOLTAGE (vdc)	SEAL/HOUSING	OPERATING PRESSURE (psig)
LFNA1250125H	12	FKM/PEEK	Vac - 30
LFNA2450125H	24	FKM/PEEK	Vac - 30
LFNA1250225H	12	EPDM/PEEK	Vac - 30
LFNA2450225H	24	EPDM/PEEK	Vac - 30

G

- Flow Restriction: 2500 Lohms ($C_v = .008$)
- Weight: 6 grams
- Internal volume: 13 microliters
- Power Consumption: 900 mW

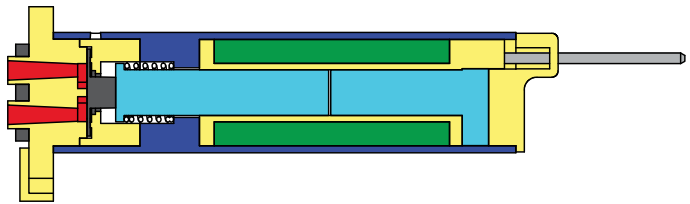

- Fluid
- Housing
- Shield
- Coil
- Seal
- Armature/
Plunger Stop
- Electrical Pin

LFN Manifolds

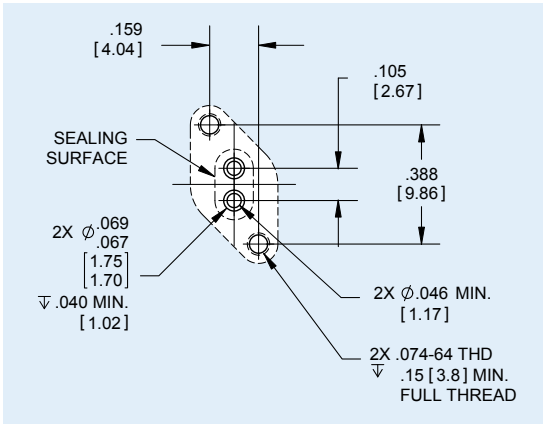

The LFNX boss is designed to simplify manifold construction. Manifold thickness is minimized, reducing fluid transport volumes and manifold material. (For full mounting boss details, use Lee drawing LSIX1001800A).

Unless otherwise specified, dimensions are in inches [mm].

An adaptor manifold (Part Number LSMX0509700B) is available for design prototyping. This allows the fluidic system to be designed, built up and tested, all prior to manifold construction. The same LFNX valve can later be used on the manifold system.

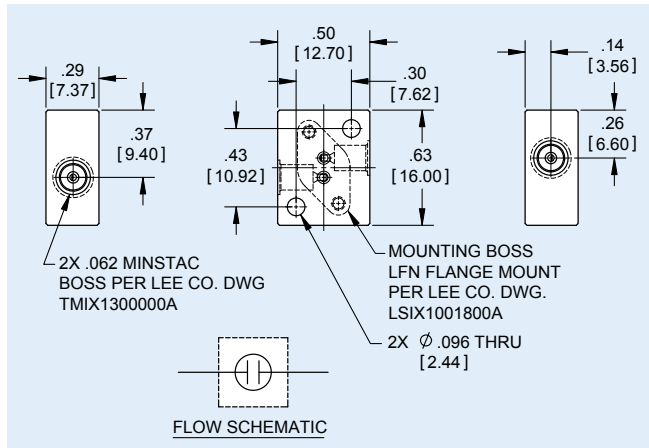

G

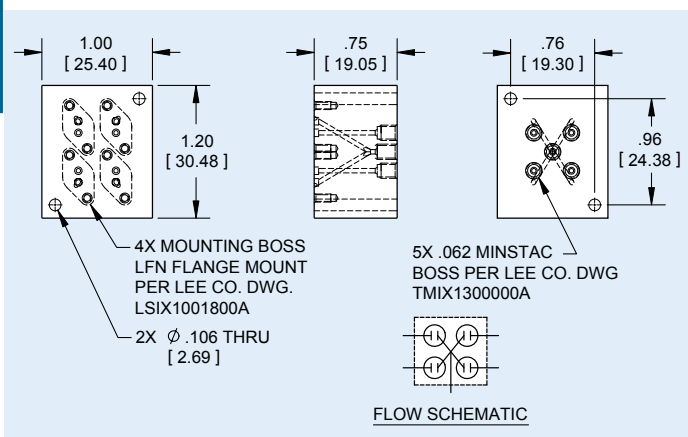

A special Lee 4 place manifold (Part Number LSMX0512650B) allows 4 valves to be mounted with a single common outlet port and 4 individually controlled inlet ports. This allows mixing of 4 streams into one outlet.

LFN Manifolds

NUMBER OF VALVES	MATERIAL	PART NUMBER	LENGTH "A"
1	PEEK	LSMX0509700B	0.63" (16.0 mm)
2	PEEK	LSMX0509520A	0.80" (20.3 mm)
3	PEEK	LSMX0509530A	1.10" (27.9 mm)
4	PEEK	LSMX0509540A	1.40" (35.6 mm)
5	PEEK	LSMX0509550A	1.70" (43.2 mm)
2	PMMA	LSMX0509560A	0.80" (20.3 mm)
3	PMMA	LSMX0509570A	1.10" (27.9 mm)
4	PMMA	LSMX0509580A	1.40" (35.6 mm)
5	PMMA	LSMX0509590A	1.70" (43.2 mm)

Replacement gaskets can be purchased using Part Number LSWX0508170A for EPDM, and LSWX0508200A for FKM. Valves should be mounted using #1-64 X 0.1875" mounting screws (Part Number LSWX0503110A).

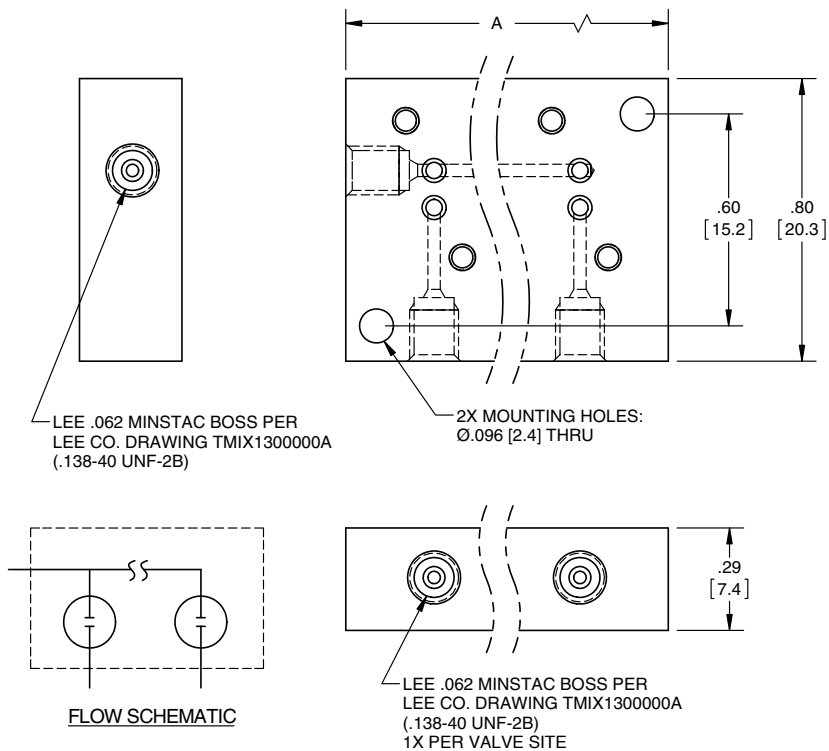

Unless otherwise specified, dimensions are in inches [mm].

GENERAL SPECIFICATIONS

The following specifications apply to all LFN Series valves, unless otherwise noted.

Cycle Life

LFN Series solenoid valves will operate for a minimum of 10 million cycles (clean water at 68°F and 10 psi). System fluid and operating conditions may affect performance.

Response Time

Typical response time is 20 ms or less at 68°F (20°C), 2 Hz air @ 10 psig.

Response times can be enhanced by using a spike and hold circuit. Refer to Engineering Section, [page S37](#).

Electrical

- LFN valves are designed to operate continuously using the nominal rated voltage (+/-5%). Response times can be enhanced by using a spike and hold circuit.

RATED VOLTAGE (vdc)	RESISTANCE (ohms)	MAXIMUM SPIKE VOLTAGE (vdc)	RECOMMENDED SPIKE DURATION (ms)	ENHANCED RESPONSE TIME (ms)
12	158	20	25	<10
24	630	40	25	<10

- Power consumption and temperature rise of the coil can be minimized using a hold voltage (50% of rated voltage).

RATED VOLTAGE (vdc)	HOLD VOLTAGE (vdc)	POWER CONSUMPTION AT HOLD VOLTAGE (W)	COIL TEMPERATURE AT HOLD VOLTAGE (70°F Ambient) °F (°C)
12	5	0.16	<100 (38)
24	10	0.16	<100 (38)

Operating Pressure

LFN valves are designed to operate in the range listed on [page G3](#).

Valve Proof pressure: 60 psig

Valve Burst pressure: 90 psig

Operating Temperature

LFN valves are designed to operate in the range shown below.

Ambient operating temperature is 40-120°F (4-49°C)

Max coil temperature: 150°F (66°C)

Filtration

Filtration of 35 microns or finer is recommended.

Typical Water Flow Characteristics

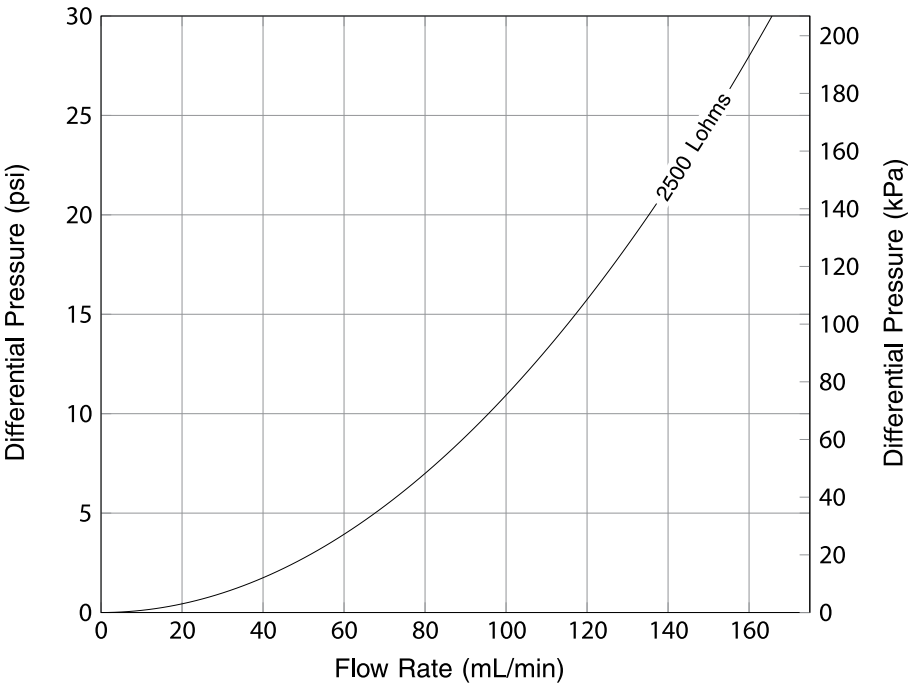

LFY Series



The LFY Series are chemically inert solenoid valves which provide precise dispensing and control of aggressive and sensitive fluids.

The LFY Series valves feature a unique internal configuration which minimizes damage to sensitive materials.

- Zero Dead Volume
- Standard (3,200 Lohm) and High Flow (1,000 Lohm) Models
- 2-way and 3-way models available
- Operating Pressures up to 30 psig
- Standard 12 and 24 vdc models available
- Low Internal Volume (as low as 18 microliters)
- Several mounting options for tube connections and manifold applications
- FKM and FFKM elastomers available
- 5 Million Cycles (minimum) service life

3-Way .054 Ports

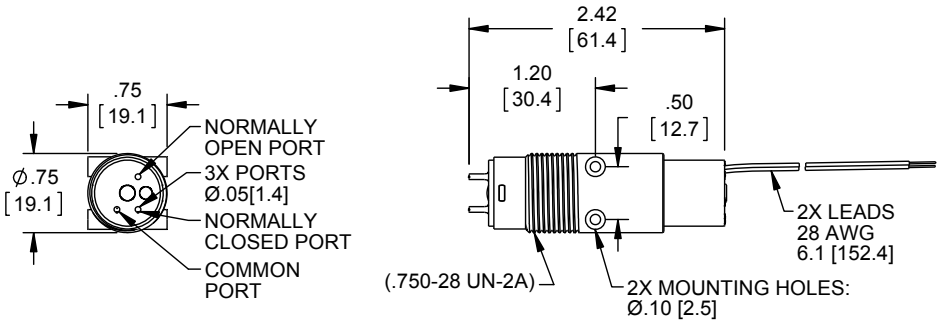

3-Way 062 MINSTAC

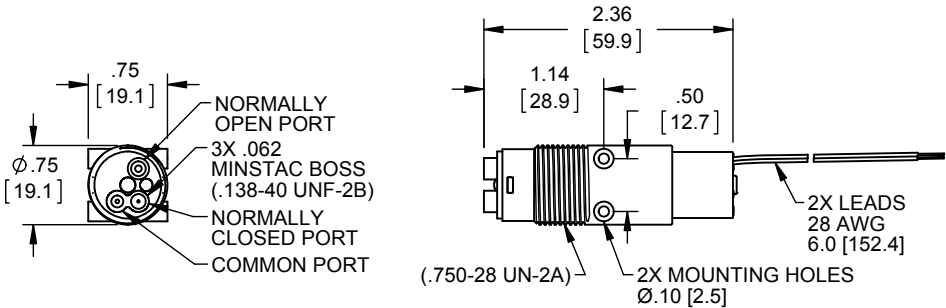

3-Way 156 MINSTAC

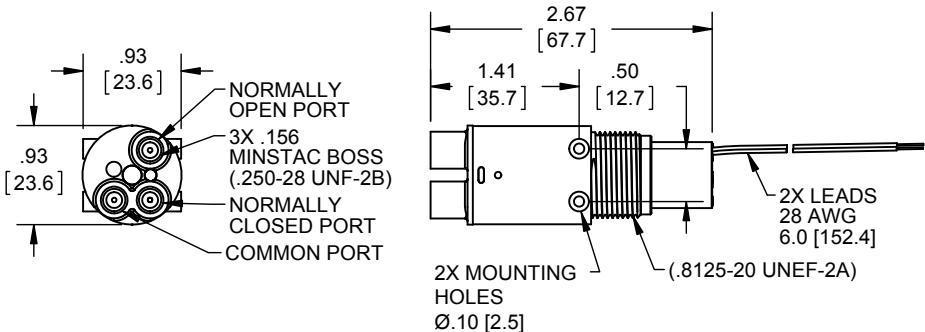

Unless otherwise specified, dimensions are in inches [mm].

3-Way .054 Ports

PART NUMBER	WETTED MATERIAL	VOLTAGE (vdc)	INTERNAL VOLUME ¹ (μL)	PRESSURE (psig)	POWER (W)
LFYA1226032H	LCP/FKM	12	22	0-30	1.5
LFYA2426032H	LCP/FKM	24	22	0-30	1.5
LFYA1228032H	LCP/FFKM	12	22	0-15	1.0
LFYA2428032H	LCP/FFKM	24	22	0-15	1.0

NOTES: (1) Internal volume per leg
Lohm Rate: 3,200 Lohms (Cv = .006)

3-Way 062 MINSTAC

PART NUMBER	WETTED MATERIAL	VOLTAGE (vdc)	INTERNAL VOLUME ¹ (μL)	PRESSURE (psig)	POWER (W)
LFYA1218032H	PPS/FFKM	12	18	0-15	1.0
LFYA2418032H	PPS/FFKM	24	18	0-15	1.0
LFYA1216032H	PPS/FKM	12	18	0-30	1.5
LFYA2416032H	PPS/FKM	24	18	0-30	1.5

NOTES: (1) Internal volume per leg
Lohm Rate: 3,200 Lohms (Cv = .006)

3-Way 156 MINSTAC²

PART NUMBER	WETTED MATERIAL	VOLTAGE (vdc)	INTERNAL VOLUME ¹ (μL)	PRESSURE (psig)	POWER (W)
LFYA1215010H	PEEK/FFKM	12	72	0-15	2.0
LFYA2415010H	PEEK/FFKM	24	72	0-15	2.0
LFYA1219010H	PEEK/FKM	12	72	0-15	2.0
LFYA2419010H	PEEK/FKM	24	72	0-15	2.0

NOTES: (1) Internal volume per leg
(2) 156 MINSTAC is compatible with many 1/4-28 systems
Lohm Rate: 1,000 Lohms (Cv = .02)



2-Way 062 MINSTAC

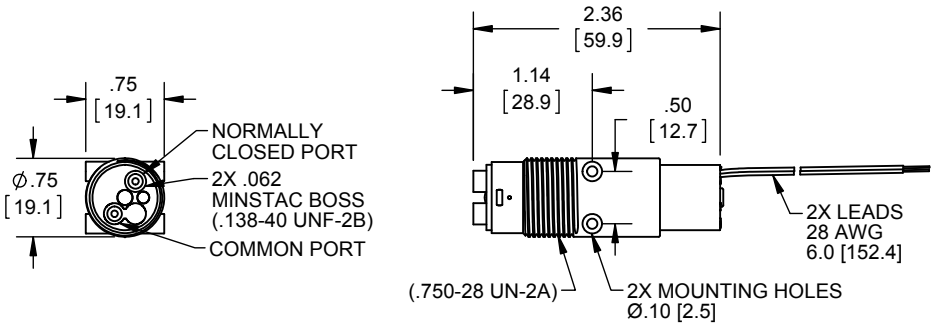

2-Way 156 MINSTAC

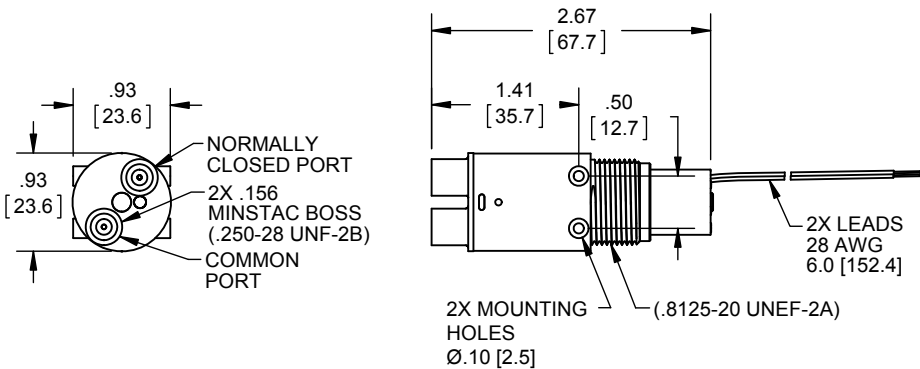

2-Way 062 MINSTAC

PART NUMBER	TYPE	WETTED MATERIAL	VOLTAGE (vdc)	INTERNAL VOLUME (μL)	PRESSURE (psig)	POWER (W)
LFYA1218232H	N.O	PPS/FFKM	12	14	0-15	1.0
LFYA2418232H	N.O.	PPS/FFKM	24	14	0-15	1.0
LFYA1218132H	N.C.	PPS/FFKM	12	11	0-15	1.0
LFYA2418132H	N.C.	PPS/FFKM	24	11	0-15	1.0
LFYA1212232H	N.O.	PPS/FKM	12	14	0-30	1.5
LFYA2412232H	N.O.	PPS/FKM	24	14	0-30	1.5
LFYA1212132H	N.C.	PPS/FKM	12	11	0-30	1.5
LFYA2412132H	N.C.	PPS/FKM	24	11	0-30	1.5

Lohm Rate: 3,200 Lohms (Cv = .006)

2-Way 156 MINSTAC¹

PART NUMBER	TYPE	WETTED MATERIAL	VOLTAGE (vdc)	INTERNAL VOLUME (μL)	PRESSURE (psig)	POWER (W)
LFYA1215210H	N.O	PEEK/FFKM	12	54	0-15	2.0
LFYA2415210H	N.O.	PEEK/FFKM	24	54	0-15	2.0
LFYA1215110H	N.C.	PEEK/FFKM	12	54	0-15	2.0
LFYA2415110H	N.C.	PEEK/FFKM	24	54	0-15	2.0
LFYA1219210H	N.O.	PEEK/FKM	12	54	0-15	2.0
LFYA2419210H	N.O.	PEEK/FKM	24	54	0-15	2.0
LFYA1219110H	N.C.	PEEK/FKM	12	54	0-15	2.0
LFYA2419110H	N.C.	PEEK/FKM	24	54	0-15	2.0

NOTES: (1) 156 MINSTAC is compatible with many 1/4-28 systems.

Lohm Rate: 1,000 Lohms (Cv = .02)

3-Way Manifold Mount

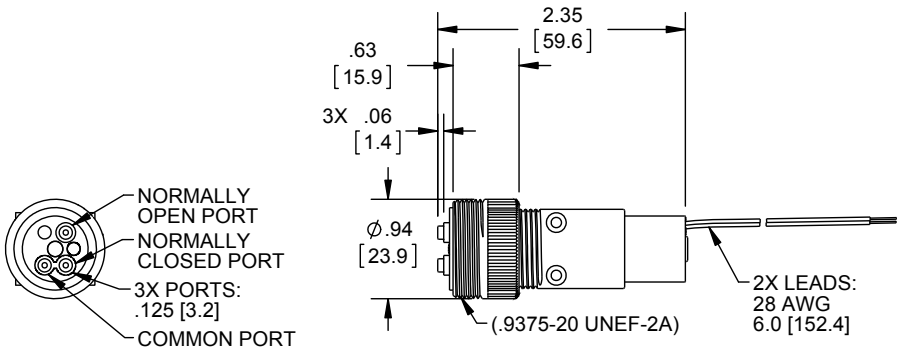

PART NUMBER	WETTED MATERIAL	VOLTAGE (vdc)	INTERNAL VOLUME ¹ (μL)	PRESSURE RANGE (psig)	POWER (W)
LFYA1236032H	PPS/FKM	12	22	0-30	1.5

NOTES: (1) Volume is per leg

Lohm Rate: 3,200 Lohms ($C_v = .006$)

Use Lee gasket Part Number LHWX0218040A (3x)

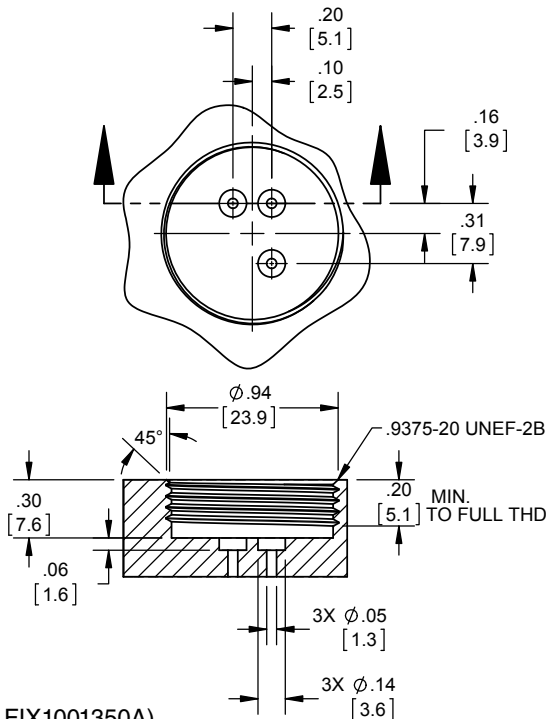

(Boss Drawing LFIX1001350A)

3-Way Flange Mount

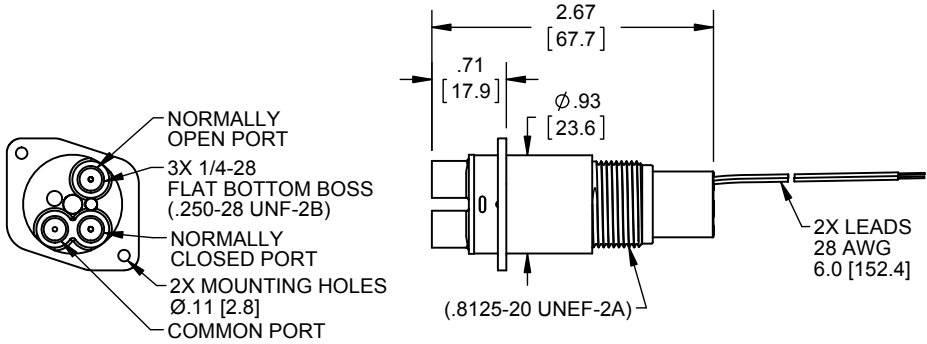

PART NUMBER	WETTED MATERIAL	VOLTAGE (vdc)	INTERNAL VOLUME ¹ (µL)	PRESSURE RANGE ² (psig)	POWER (W)
LFYX0509700B	PEEK/FKM	24	54	0-15	2.0

NOTES: (1) Volume is per leg

(2) Max. pressure differential (between ports) is 17 psid.

Lohm Rate: 1,000 Lohms (Cv = .02)

Panel Mounting

This valve requires a 0.95" (25 mm) diameter clearance hole with a mounting hole for #2 or 2 mm screws.



GENERAL SPECIFICATIONS

The following specifications apply to all LFY Series valves unless otherwise noted.

Cycle Life

The LFY valves will operate for a minimum of 5 million cycles on water at standard temperature and pressure conditions. Specific application conditions and fluids may affect the life of the valve.

Operating Pressure

The LFY valves will operate properly within the range specified. Excess pressure may adversely affect the cycle life.

Valve Proof Pressure 2 x normal rated pressure

Valve Burst Pressure 3 x normal rated pressure

Operating Temperature

- Ambient operating range is 60°F to 118°F (16°C - 48°C)
- Maximum allowable solenoid coil temperature is 250°F (121°C).
- Increasing coil temperature tends to limit performance. Valve duty cycle and energized time must be evaluated so coil temperature does not exceed 250°F (121°C).

Response Time

Typical response time for the LFY valve is 50 ms at 65°F (18°C). Lower operating temperatures can dramatically increase response time. Extended periods of inactivity may also increase the initial response time.

Port Connections

Several different port connections are available:

- 054 ports: these are designed for use with 0.040" (1.0 mm) I.D. flexible tubing
- 062 MINSTAC: for use with Lee 062 MINSTAC Teflon® tubing system
- 156 MINSTAC: for use with 156 MINSTAC Teflon tubing systems (also compatible with many 1/4-28 flat bottom fitting systems).
- Manifold mount for use with custom manifolds.

Filtration

Fluid used in LFY Series valves should be filtered to 5 microns or finer.

Wetted Materials

Wetted materials used in the LFY series are:

PPS: polyphenylene sulfide

LCP: liquid crystal polymer

PEEK: polyetheretherketone

FKM: fluoroelastomer

FFKM: perfluoroelastomer

Valve Mounting

LFY valves may be mounted using #2 (2 mm) screws to a flat surface. Sufficient length must be provided to allow for the valve thickness and still allow proper engagement into the mounting surface. Screws should be torqued to 15 in-oz (0.11 N-m). Nylon screws can be used to prevent over torquing.

Nylon mounting Screws (#2)

- LHWX0203770A: 1" long
- LHWX0203990A: 1.25" long

Panel Mounting

- 3200 Lohm valves require a 0.79" (20 mm) clearance hole with a maximum panel thickness of 0.44" (11 mm). Use panel nut LHWX0203250A to mount the valve.
- 1000 Lohm valves require a 0.83" (21 mm) clearance hole with a maximum panel thickness of .44" (11 mm). Use panel nut LHWX0203760A to mount valve.

Electrical Characteristics

LFY valves are designed to run at the rated voltage +/- 5%

**Typical Flow Characteristics
3,200 and 1,000 Lohm LFY Series Valves**

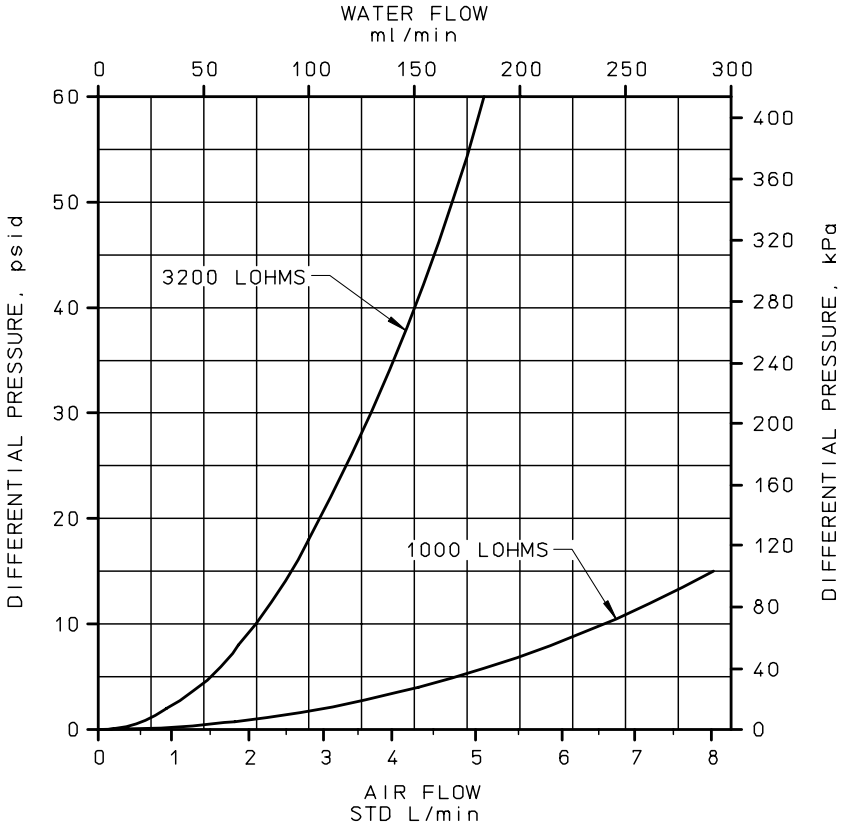

LPL Series

Lee LPL Series solenoid pumps provide accurate, repeatable, fixed volume dispensing in a small lightweight package. A normally closed seat prevents siphoning when the pump is de-energized.

LPL solenoid pumps are ideally suited for applications that require a precise, fixed volume dispense. The pump's accuracy and repeatability eliminate the need for calibration and adjustment.

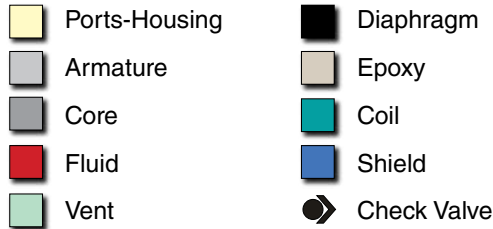
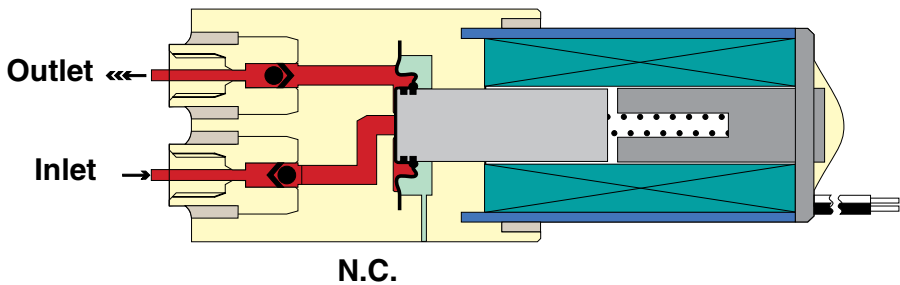

- LPL pumps provide the designer with greater flexibility
- Inert wetted materials (PEEK body)
Choice of FKM and EPDM as standard elastomers
- 12 and 24 volt coil
- Low power consumption: 2 and 2.5 W models
- Fast: 2 Hz operation
- Standard 50 μ L dispense, special sizes also available
- Self priming
- Long life: 10 million cycles

062 MINSTAC Ports

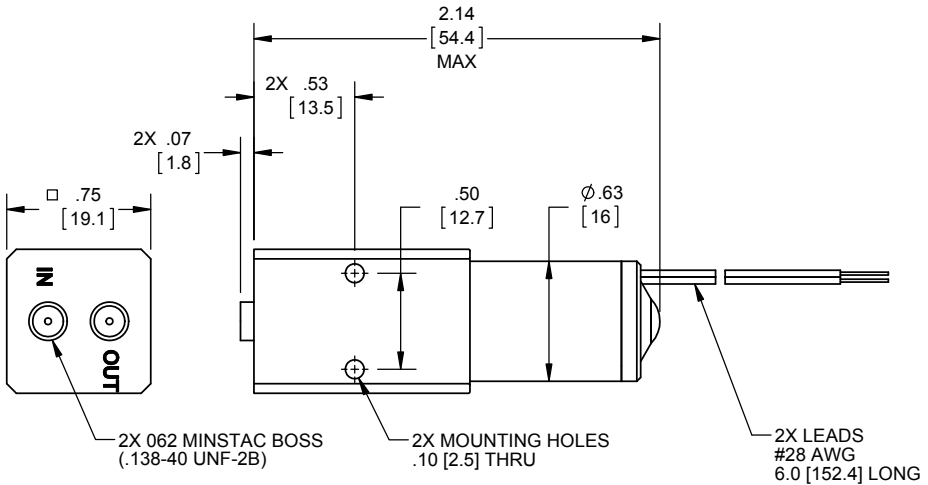

Unless otherwise specified, dimensions are in inches [mm].

PART NUMBER ¹	ACCURACY (%)	POWER (W)	ELASTOMER	VOLUME (µL)
LPLA __ 10350L	3	2	FKM	50
LPLA __ 11350L	3	2	EPDM	
LPLA __ 10550L	5	2	FKM	
LPLA __ 11550L	5	2	EPDM	
LPLA __ 10050L	10	2	FKM	
LPLA __ 11050L	10	2	EPDM	

NOTES: (1) Pumps are available in 12 and 24 vdc configurations.

LPLA __ 10350L

Coil Voltage: 12 = 12 vdc
24 = 24 vdc

Straight Ports

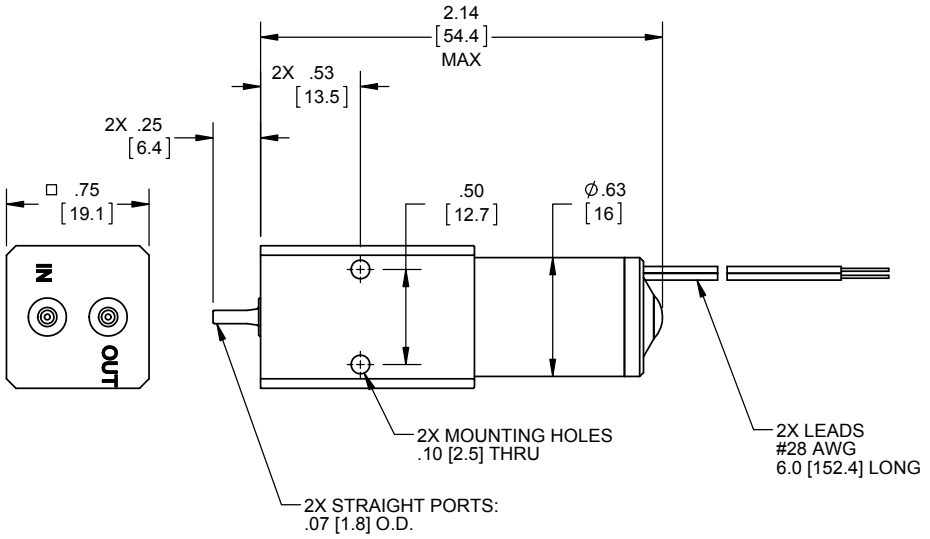

Unless otherwise specified, dimensions are in inches [mm].

PART NUMBER ¹	ACCURACY (%)	POWER (W)	ELASTOMER	VOLUME (µL)
LPLA __ 20350L	3	2	FKM	50
LPLA __ 21350L	3	2	EPDM	
LPLA __ 20550L	5	2	FKM	
LPLA __ 21550L	5	2	EPDM	
LPLA __ 20050L	10	2	FKM	
LPLA __ 21050L	10	2	EPDM	

NOTES: (1) Pumps are available in 12 and 24 vdc configurations.

LPLA __ 20350L

↑
Coil Voltage: 12 = 12 vdc
24 = 24 vdc

1/4-28 Flat Bottom Boss

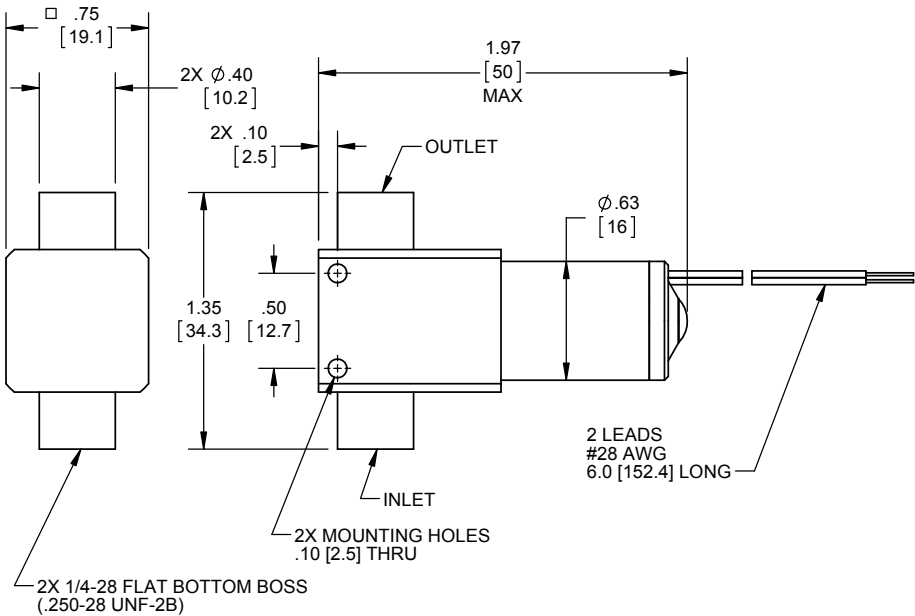

Unless otherwise specified, dimensions are in inches [mm].

PART NUMBER ¹	ACCURACY (%)	POWER (W)	ELASTOMER	VOLUME (µL)
LPLA __ 30350L	3	2	FKM	50
LPLA __ 31350L	3	2	EPDM	
LPLA __ 30550L	5	2	FKM	
LPLA __ 31550L	5	2	EPDM	
LPLA __ 30050L	10	2	FKM	
LPLA __ 31050L	10	2	EPDM	

NOTES: (1) Pumps are available in 12 and 24 vdc configurations.

LPLA __ 30350L

Coil Voltage: 12 = 12 vdc
24 = 24 vdc

Standard Manifold Mount

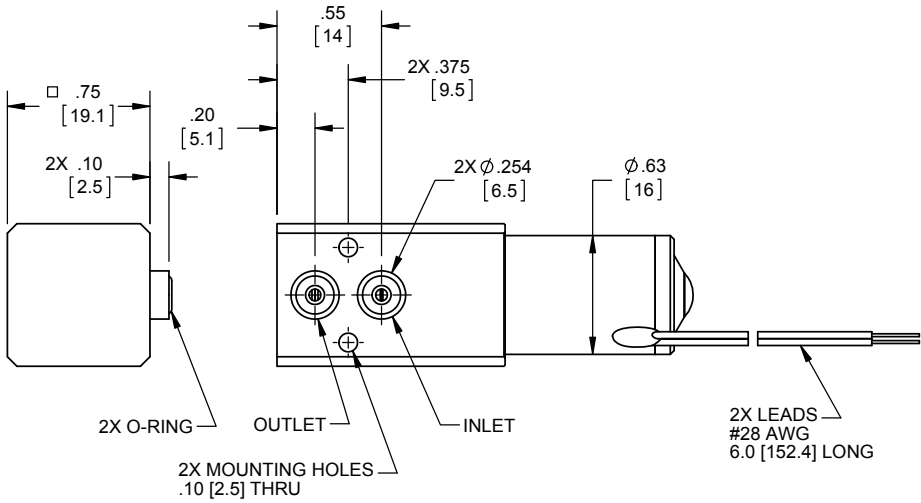

See [page I10](#) for mounting boss drawing LSIX01001110A.

Unless otherwise specified, dimensions are in inches [mm].

PART NUMBER ¹	ACCURACY (%)	POWER (W)	ELASTOMER	VOLUME (μ L)
LPLA __ 40350L	3	2	FKM	50
LPLA __ 41350L	3	2	EPDM	
LPLA __ 40550L	5	2	FKM	
LPLA __ 41550L	5	2	EPDM	
LPLA __ 40050L	10	2	FKM	
LPLA __ 41050L	10	2	EPDM	

NOTES: (1) Pumps are available in 12 and 24 vdc configurations.

LPLA __ 40350L

↑ Coil Voltage: 12 = 12 vdc
24 = 24 vdc

LPL2 – Combination Manifold/Soft Tube Port

The LPL2 pump features a port head design that allows tubing connections (push on ports) and manifold mounting. A special end cap design simplifies electrical connections and wiring harnesses.

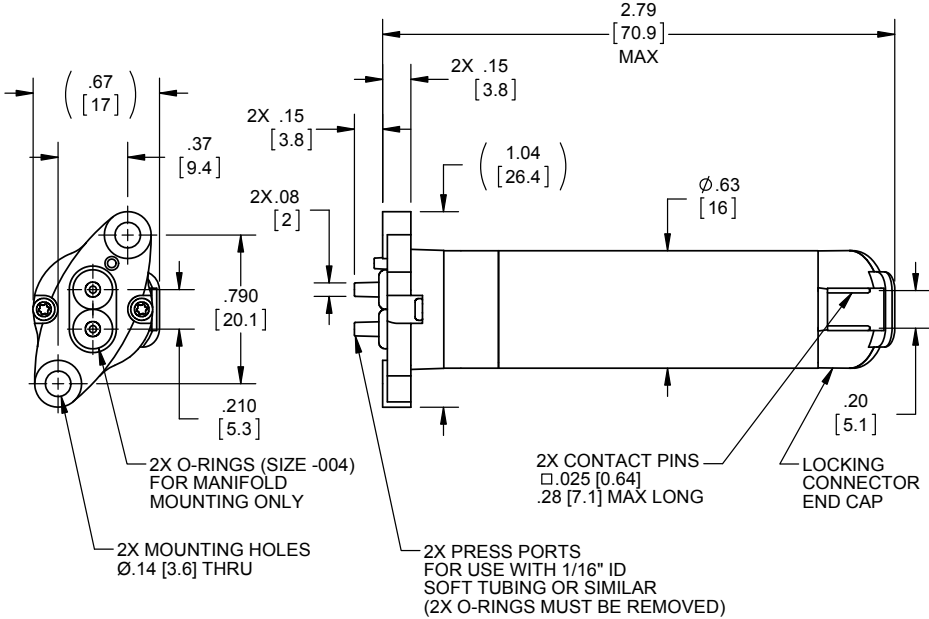

Unless otherwise specified, dimensions are in inches [mm].

See [page I10](#) for mounting boss drawing LSIX01001440A.

PART NUMBER ¹	ACCURACY (%)	POWER (W)	WEIGHT (g)	ELASTOMER	VOLUME (μ L)
LPLA __ _50650L	6	2.5	53	FKM	50
LPLA __ _50625L	12			FKM	25
LPLA __ _51650L	6			EPDM	50
LPLA __ _51625L	12			EPDM	25

NOTES: (1) Pumps are available in 12 and 24 vdc configurations.

LPLA __ _50650L

Coil Voltage: 12 = 12 vdc
24 = 24 vdc

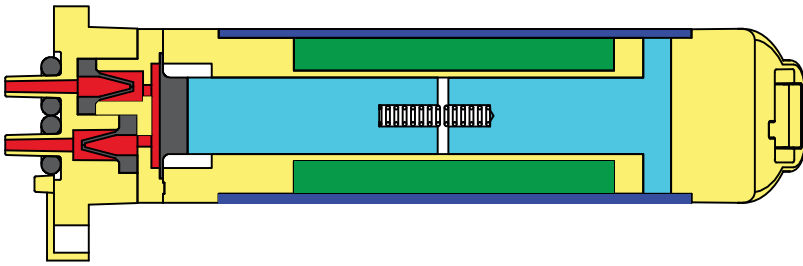

- Fluid
- Coil
- Elastomer (check valve/seal/o-rings)
- Shield
- Housing
- Armature/Plunger Stop

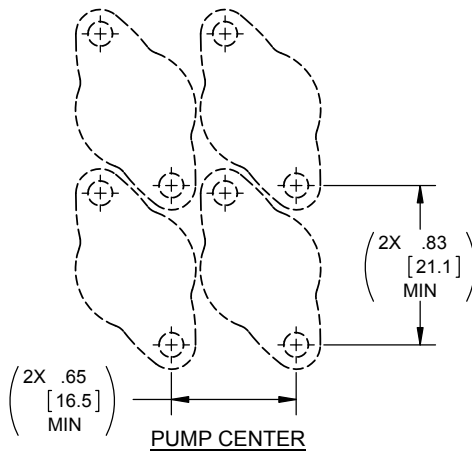

Unless otherwise specified, dimensions are in inches [mm].

GENERAL SPECIFICATIONS

The following specifications apply to all LPL Series pumps, unless otherwise noted.

Life Expectancy

The LPL Series pumps will operate for a minimum of 10 million cycles on clean water. Fluids may affect actual life.

Operating Pressure

- Maximum case pressure is 5 psig
- Total head range is -30 to +30 inches water
- Inlet/Outlet pressure will affect dispense volume
- Inlet/Outlet restrictions may affect pumped volume

Pumped Volume

- The standard dispensed volume is 50 μ L. 25 μ L available for combo port style.
- Special volumes are also available
- Repeatability of pumped volume is 2%
- Coefficient of Variation (CV) = +/- 0.3%

Response Time

Maximum operating frequency is 2 Hz. Cycling pump faster will adversely affect dispense accuracy. Fluid properties (i.e. viscosity) and flow restrictions may reduce maximum operating speed.

Filtration

Filtration of 35 microns or finer is recommended.

Electrical Characteristics

- Lead wires are #28 PTFE insulated wire
- Leads are white (no coil polarity)

LPL2 Only

- End Cap connector is compatible with AMP part number: 104257-2
- Lead wire assemblies available
 - 6" assembly: LSWX0504300A
 - 24" assembly: LSWX0606700A

Operating Temperature

- Ambient operating temperature is 60 - 150°F (16 - 66°C)
- Max. coil temperature is 180°F (85°C)
- Lower operating temperatures may require special elastomers to ensure proper dispensing.

Port Connections

All ported pumps (non manifold) can be mounted using #2 or 2 mm screws. Adequate length must be allowed for pump housing (0.75") and proper engagement into mounting plate. Mounting screws should be torqued to 10-15 in-oz (0.071 - 0.106 N-m). Manifold mounted pumps require a properly prepared boss. #2 or 2 mm screws should be used for attachment.

Standard Manifold Mount

Lee Drawing LSIX1001110A

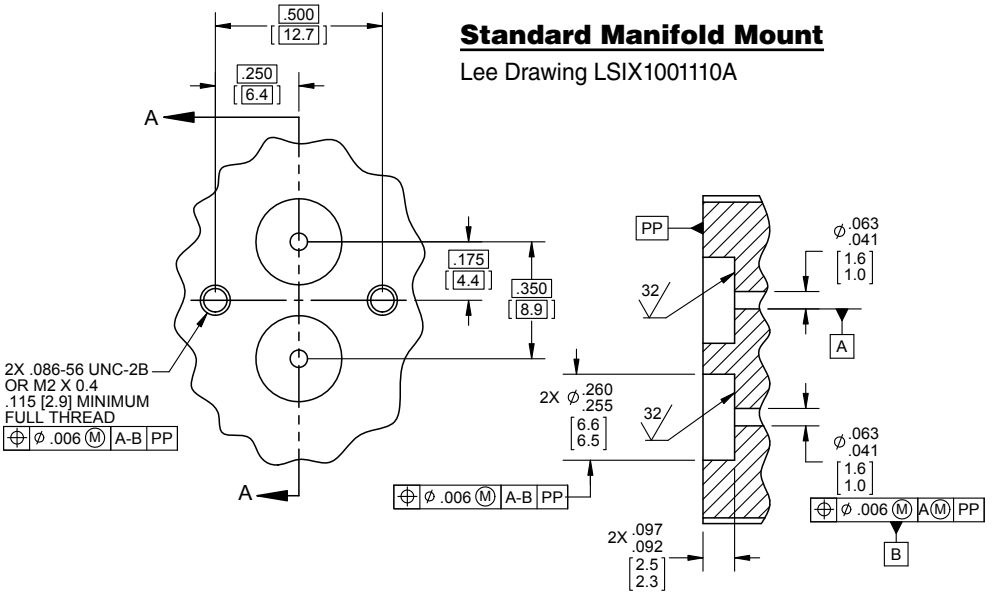

LPL2

Lee Drawing LSIX1001440A

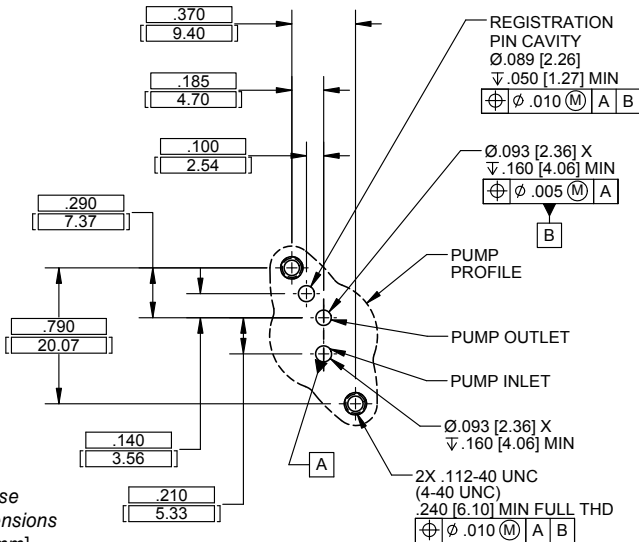

Unless otherwise specified, dimensions are in inches [mm].

LPV Series

J



LPV Series pumps are variable volume, positive displacement pumps that feature unparalleled reliability and consistent performance. Their small size, light weight and maintenance free design permit the pumps to be located where the fluidic requirements dictate, regardless of maintenance accessibility. This makes them ideal for replacing conventional syringe and peristaltic pumps. This also allows the pumps to be located on or near the sample arm, further reducing the required transport volume of the system.

Standard LPV Pumps incorporate a stacked can motor, which creates a smaller, lighter package. A home sensor is available as an option.

High Performance LPV Pumps use a hybrid stepper motor, which allows smaller dispense increments and higher pressures. Encoders and home sensors are included with these pumps, allowing positive feedback.

High Performance pumps are also available with dual seals. The second seal creates a “flushing” chamber which allows the use of a barrier fluid. Flushing of the piston to prevent build up is also possible.

All LPV Series Pumps Offer:

- Compact Size, Light Weight
- Low Power Consumption
- Maintenance Free Design
- Self Priming Operation



LPV Series

CONFIGURATION A

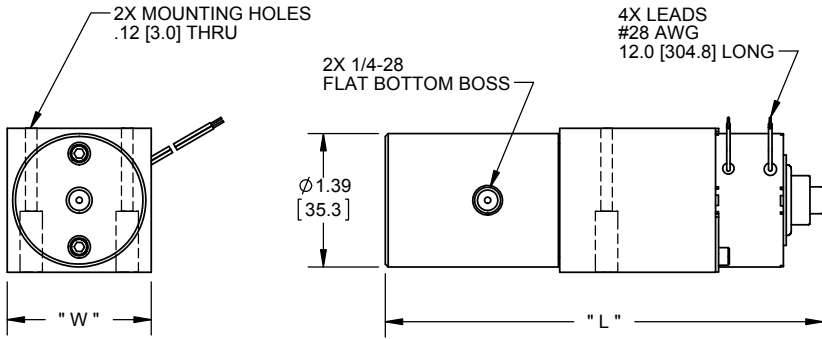

CONFIGURATION B

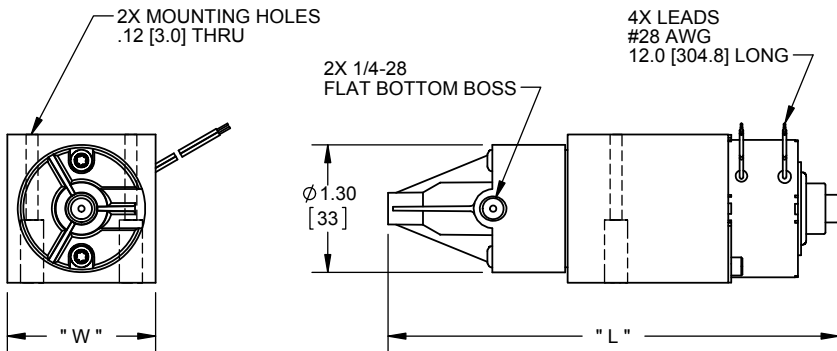

Unless otherwise specified, dimensions are in inches [mm].

PART NUMBER	VOLUME (μL)	PISTON MATERIAL	PORT HEAD MATERIAL	FULL STEP DISPENSE (μL)	MAXIMUM DISCHARGE PRESSURE (psig)	
LPVA1020050L	50	TZP	PMMA	0.1	30	
LPVA1050050L		TZP	PEEK			
LPVA1051050L		sapphire	PEEK			
LPVA1520025D	250	TZP	PMMA	0.5	30	
LPVA1550025D		TZP	PEEK			
LPVA1551025D		sapphire	PEEK			
LPVA1520075D	750	TZP	PMMA	1.5	15	
LPVA1550075D		TZP	PEEK			
LPVA1551075D		sapphire	PEEK			

LPV Series

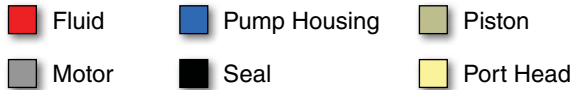
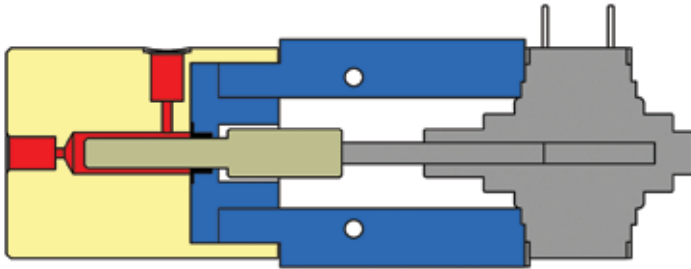

- Wetted Materials: Piston and Port Head (see chart below), UHMW-PE, EPDM
- External valving required
- Motor: Bipolar
- Power: 260-290 mA / phase (250 and 750 μ L)
210-240mA / phase (50 μ L)

	CV% (10% Dispensed Volume)	CV% (Full Dispensed Volume)	MAX. SPEED HALF STEPS (pps)	LENGTH "L"	WIDTH "W"	CONFIGURA- TION
	0.4% (@5 μ L)	0.04% (@50 μ L)	1000	3.90" (99.1 mm)	1.25" (31.7 mm)	A
	0.4% (@25 μ L)	0.04% (@250 μ L)	1000	4.58" (116.3 mm)	1.5" (38.1 mm)	A
	0.4% (@75 μ L)	0.04% (@750 μ L)	1000	4.61" (117.1 mm)	1.5" (38.1 mm)	A B B

LPV Series with Home Sensor

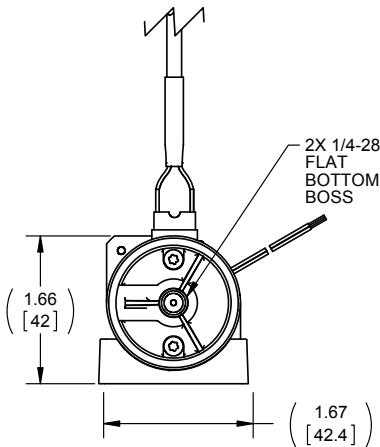
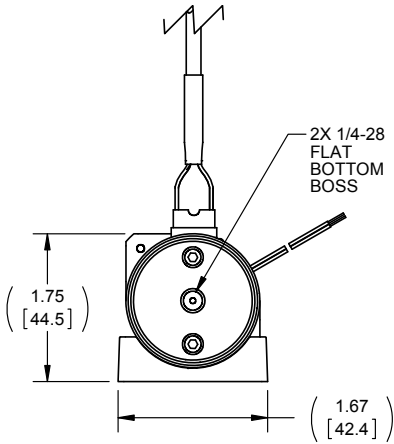

CONFIGURATION A

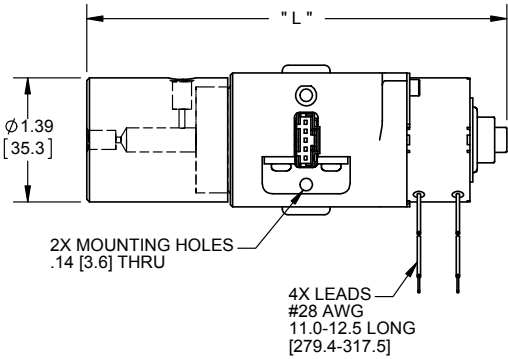

CONFIGURATION B

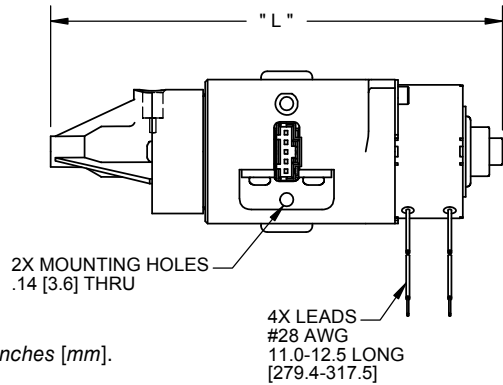

Unless otherwise specified, dimensions are in inches [mm].

PART NUMBER	VOLUME (μL)	PISTON MATERIAL	PORT HEAD MATERIAL	FULL STEP DISPENSE (μL)	MAXIMUM DISCHARGE PRESSURE (psig)	
LPVA1520125D	250	TZP	PMMA	0.5	30	
LPVA1550125D		TZP	PEEK			
LPVA1551125D		sapphire	PEEK			
LPVA1520175D	750	TZP	PMMA	1.5	15	
LPVA1550175D		TZP	PEEK			
LPVA1551175D		sapphire	PEEK			

LPV Series with Home Sensor

J

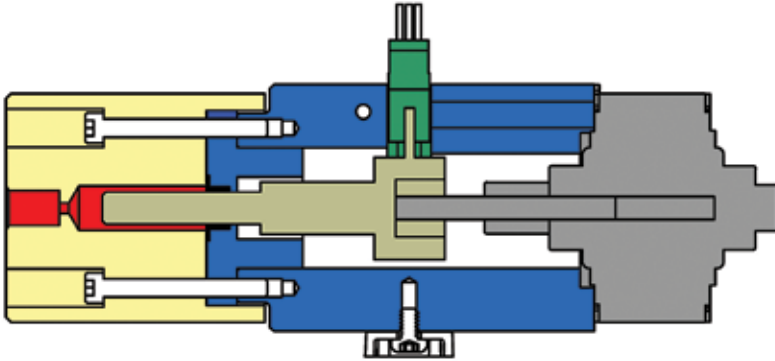

- Fluid
- Pump Housing
- Piston
- Motor
- Seal
- Port Head
- Home Sensor

- Wetted Materials: Piston and Port Head (see chart below), UHMW-PE, EPDM
- External valving required
- Home Sensor: Honeywell Micro Switch Part Number: 2005-001
- Motor: Bipolar
- Power: 260-290 mA / phase (250 and 750 μ L)

	CV% (10% Dispensed Volume)	CV% (Full Dispensed Volume)	MAX. SPEED HALF STEPS (pps)	LENGTH "L"	CONFIGURA- TION
	0.4% (@25 μ L)	0.04% (@250 μ L)	1000	4.74" (120.4 mm)	A
	0.4% (@75 μ L)	0.04% (@750 μ L)	1000	4.74" (120.4 mm)	A
				4.8" (121.9 mm)	B
				4.8" (121.9 mm)	B

LPV Series Manifold Mount

CONFIGURATION A

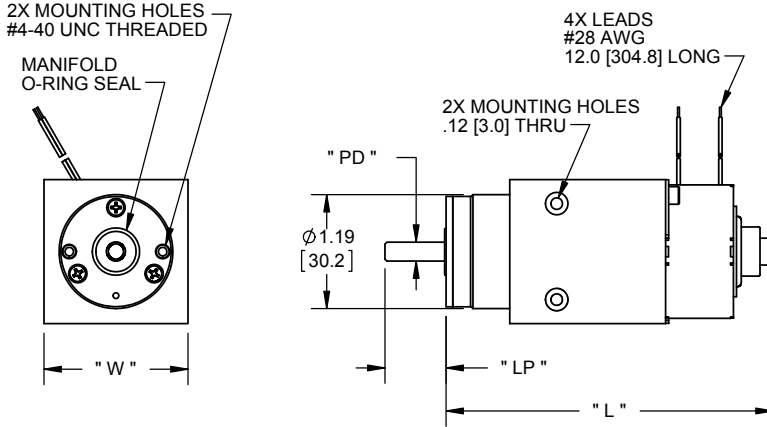

Unless otherwise specified, dimensions are in inches [mm].

For manifold boss, use Lee Drawing

50 μ L: LSIX1001350A

250 μ L: LSIX1001140A

750 μ L: LSIX1001120A

PART NUMBER	VOLUME (μ L)	PISTON MATERIAL	FULL STEP DISPENSE (μ L)	MAXIMUM DISCHARGE PRESSURE (psig)	CV% (10% Dispensed Volume)	
LPVA1000050L	50	TZP	0.1	30	0.4% (@5 μ L)	
LPVA1001050L	50	sapphire				
LPVA1500025D	250	TZP	0.5	30	0.4% (@25 μ L)	
LPVA1501025D	250	sapphire				
LPVA1500075D	750	TZP	1.5	15	0.4% (@75 μ L)	
LPVA1501075D	750	sapphire				

LPV Series Manifold Mount

J

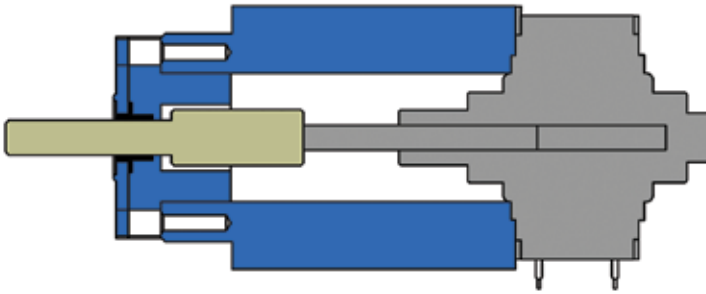

- Wetted Materials: Piston (see chart below), UHMW-PE, EPDM, 316 SS
- External valving required
- Motor: Bipolar
- Power: 260-290 mA / phase (250 and 750 μ L)
210-240mA / phase (50 μ L)

	CV% (Full Dispensed Volume)	MAX. SPEED HALF STEPS (pps)	MOUNTING BOSS DRAWING	LENGTH "L" (mm)	PISTON LENGTH "LP" (mm)	PISTON DIAMETER "PD" (mm)	WIDTH "W" (mm)
	0.04% (@ 50 μ L)	1000	LSIX1001350A	2.96" (68.3 mm)	0.51" (13.0 mm)	0.088" (1.68 mm)	1.25" (31.75 mm)
	0.04% (@ 250 μ L)	1000	LSIX1001140A	3.42" (86.9 mm)	0.72" (18.3 mm)	0.197" (5.00 mm)	1.5" (38.1 mm)
	0.04% (@ 750 μ L)	1000	LSIX1001120A	3.42" (86.9 mm)	0.57" (14.5 mm)	0.341" (8.66 mm)	1.5" (38.1 mm)

LPV Series Manifold Mount with Home Sensor

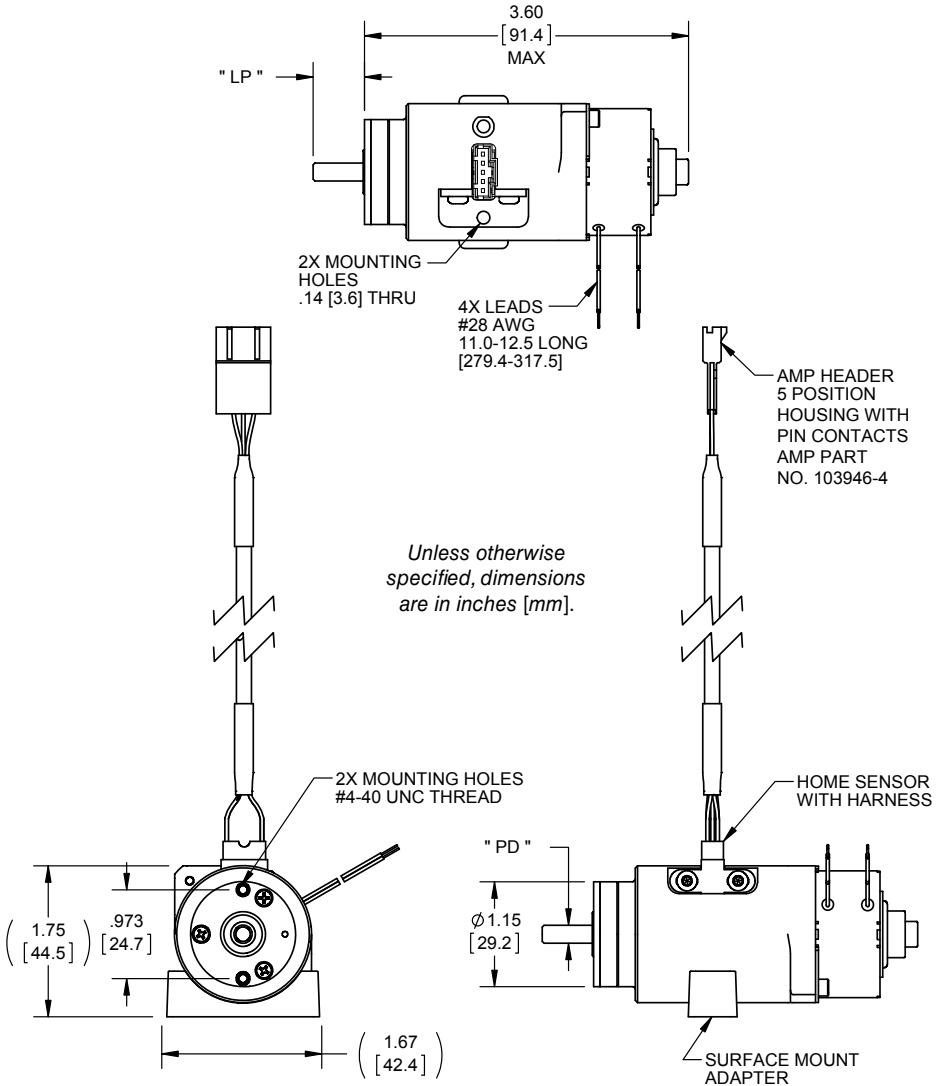

PART NUMBER	VOLUME (µL)	PISTON MATERIAL	FULL STEP DISPENSE (µL)	MAXIMUM DISCHARGE PRESSURE (psig)	
LPVA1500125D	250	TZP	0.5	30	
LPVA1501125D	250	sapphire			
LPVA1500175D	750	TZP	1.5	15	
LPVA1501175D	750	sapphire			

LPV Series Manifold Mount with Home Sensor

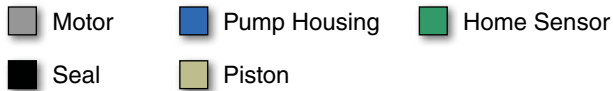
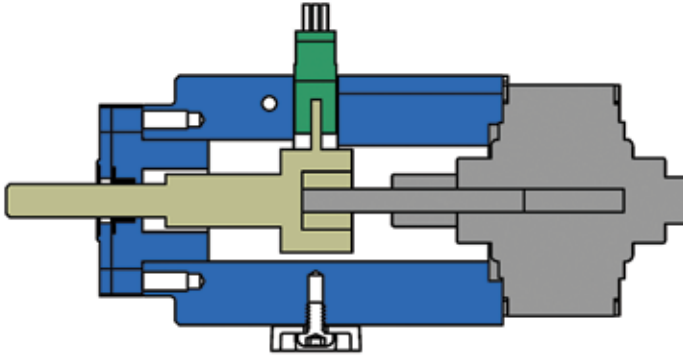

- Wetted Materials: Piston (see chart below), UHMW-PE, EPDM, 316 SS
- External valving required
- Home Sensor: Honeywell Micro Switch Part Number: HOA2005-001
- Motor: Bipolar
- Power: 260-290 mA / phase

	CV% (10% Dispensed Volume)	CV% (Full Dispensed Volume)	MAX. SPEED HALF STEPS (pps)	MOUNTING BOSS DRAWING	PISTON LENGTH "LP"	PISTON DIAMETER "PD"
	0.4% (@25 μ L)	0.04% (@250 μ L)	1000	LSIX1001140A	0.72" (18.3 mm)	0.197" (5.00 mm)
	0.4% (@75 μ L)	0.04% (@750 μ L)	1000	LSIX1001120A	0.57" (14.5 mm)	0.341" (8.66 mm)

LPV Series High Performance

CONFIGURATION A

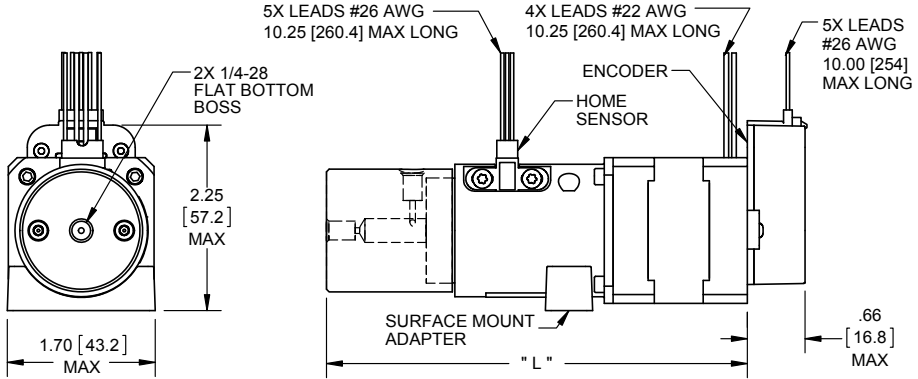

CONFIGURATION B

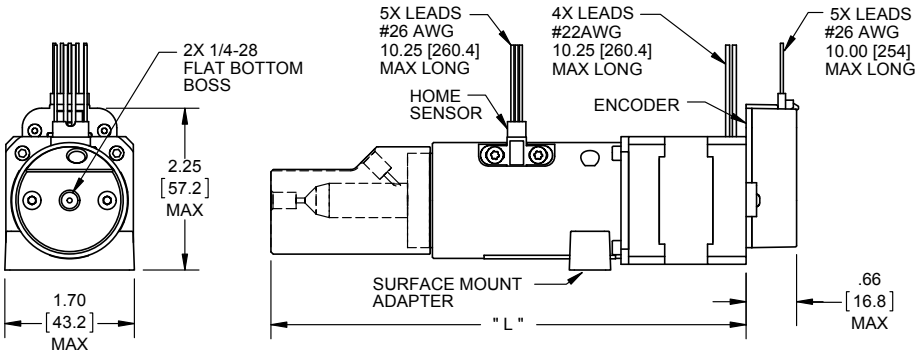

Unless otherwise specified, dimensions are in inches [mm].

PART NUMBER	VOLUME (μL)	PORT HEAD MATERIAL	FULL STEP DISPENSE (μL)	MAXIMUM DISCHARGE PRESSURE (psig)	
LPVA1720350L	50	PMMA	0.04	60	
LPVA1750350L		PEEK			
LPVA1720325D	250	PMMA	0.2	60	
LPVA1750325D		PEEK			
LPVA1720375D	750	PMMA	0.47	30	
LPVA1750375D		PEEK			
LPVA1720310H	1000	PMMA	0.4	30	
LPVA1750310H		PEEK			
LPVA1720330H ¹	3000	PMMA	1	95	
LPVA1750330H ¹		PEEK			

NOTE: 1. Wetted material includes 316 Stainless Steel.

LPV Series High Performance

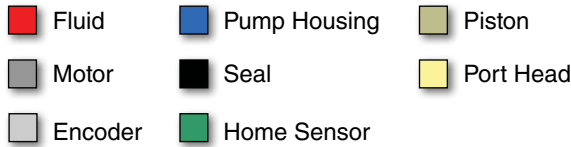
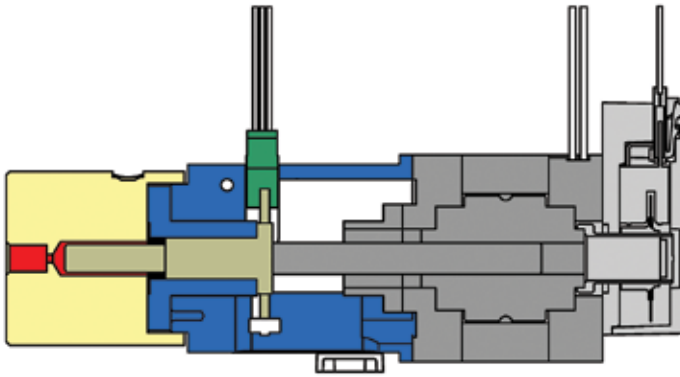

- Wetted Materials: Port Head (see chart below), TZP, UHMW PE
- External valving required
- Encoder and home sensor equipped
- Motor: Bipolar
- Power: 400-420 mA / phase

	CV% (10% Dispensed Volume)	CV% (Full Dispensed Volume)	MAX. SPEED HALF STEPS (pps)	LENGTH "L"	CONFIGURA- TION
	0.3% (@5 µL)	0.03% (@50 µL)	5000	4.84" (122.9 mm)	A
	0.3% (@25 µL)	0.03% (@250 µL)	4000	4.84" (122.9 mm)	A
	0.3% (@75 µL)	0.03% (@750 µL)	4000	5.25" (133.3 mm)	A
	0.3% (@100 µL)	0.03% (@1000 µL)	4000	6.21" (157.7 mm)	B
	0.3% (@300 µL)	0.03% (@3000 µL)	4000	6.32" (160.5 mm)	A

LPV Series High Performance Manifold Mount

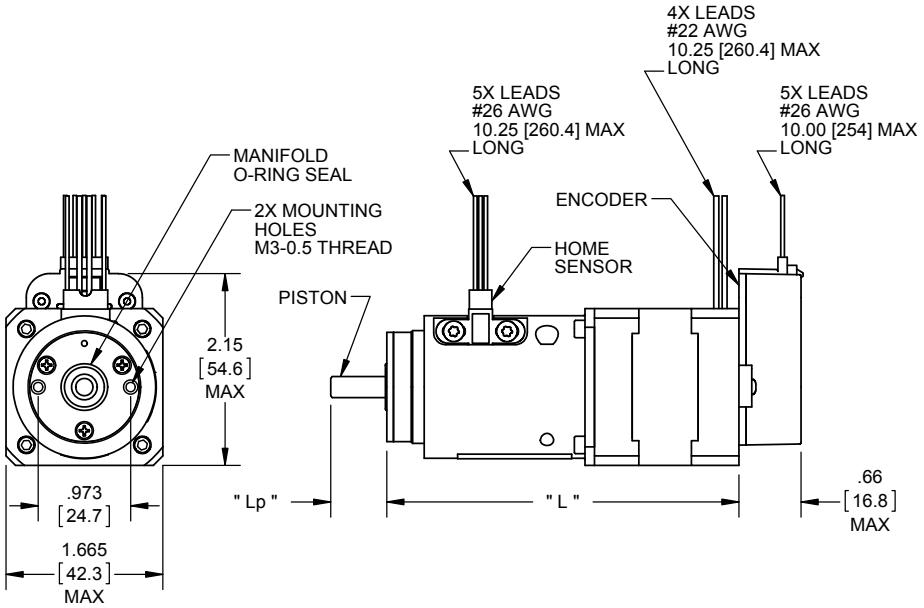

Unless otherwise specified, dimensions are in inches [mm].

PART NUMBER	VOLUME (μL)	FULL STEP DISPENSE (μL)	MAXIMUM DISCHARGE PRESSURE (psig)	CV% (10% Dispensed Volume)	
LPVA1700350L	50	0.04	60	0.3% (@5 μL)	
LPVA1700325D	250	0.2	60	0.3% (@25 μL)	
LPVA1700375D	750	0.47	30	0.3% (@75 μL)	
LPVA1700310H	1000	0.4	30	0.3% (@100 μL)	
LPVA1700330H	3000	1	95	0.3% (@300 μL)	

LPV Series High Performance Manifold Mount

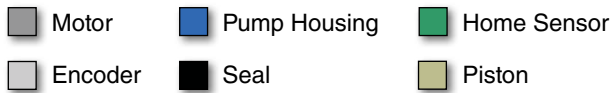
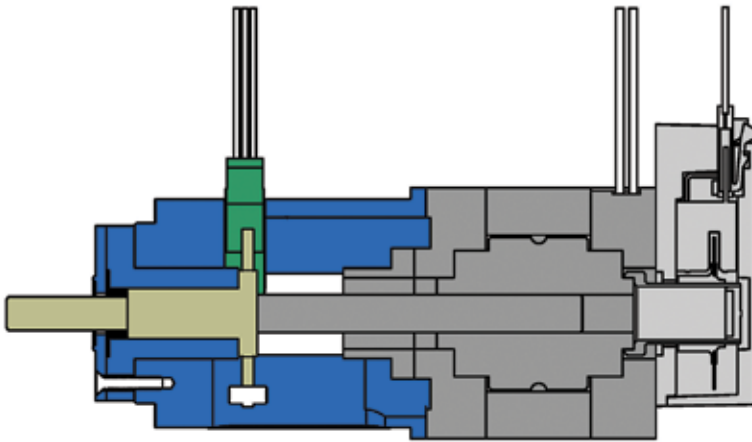

- Wetted Materials: TZP, UHMW PE, 316 SS
- External valving required
- Encoder and home sensor equipped
- Motor: Bipolar
- Power: 400-420 mA / phase

	CV% (Full Dispensed Volume)	MAX. SPEED HALF STEPS (pps)	MOUNTING BOSS DRAWING	LENGTH "L" (mm)	PISTON LENGTH "LP" (mm)	PISTON DIAMETER "PD" (mm)
	0.03% (@ 50 μ L)	5000	LSIX1001420A	3.78" (96.0 mm)	0.6" (15.2 mm)	0.1" (2.5 mm)
	0.03% (@ 250 μ L)	4000	LSIX1001140A	3.78" (96.1 mm)	0.6" (15.2 mm)	0.22" (5.6 mm)
	0.03% (@ 750 μ L)	4000	LSIX1001120A	3.89" (98.8 mm)	0.65" (16.5 mm)	0.34" (8.6 mm)
	0.03% (@ 1000 μ L)	4000	LSIX1001460A	4.58" (116.3 mm)	0.95" (24.1 mm)	0.32" (8.1 mm)
	0.03% (@ 3000 μ L)	4000	LSIX1001150A	4.70" (119.4 mm)	0.8" (20.3 mm)	0.45" (11.4 mm)

LPV Series High Performance - Dual Seal

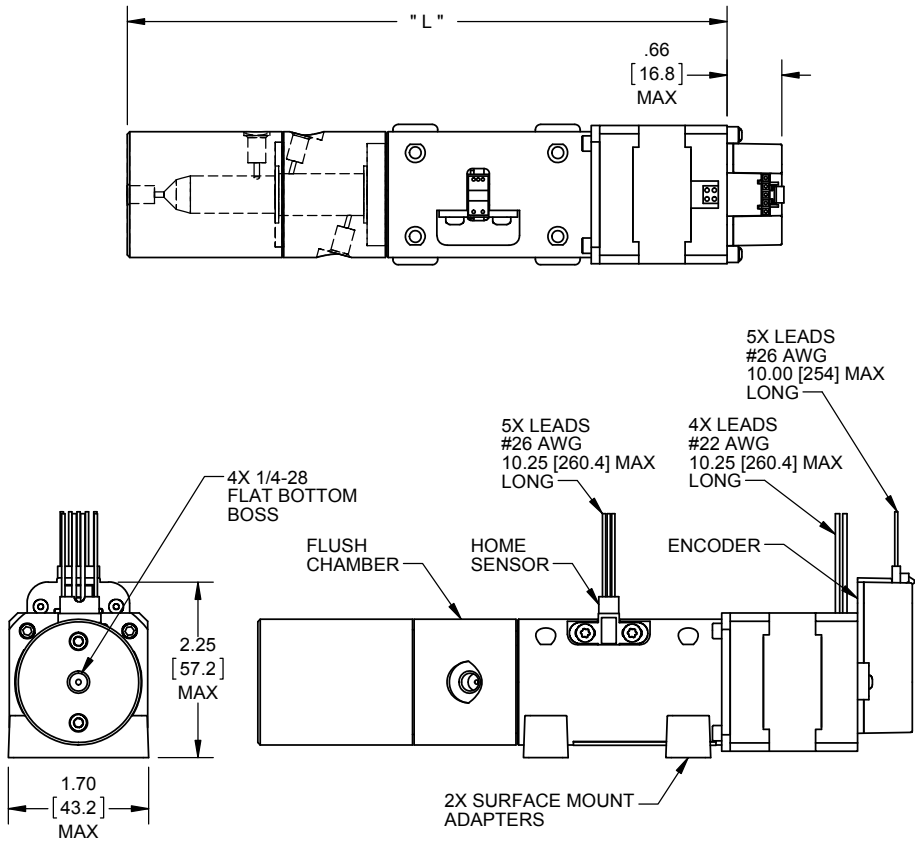

Unless otherwise specified, dimensions are in inches [mm].

PART NUMBER	VOLUME (μL)	PORT HEAD MATERIAL	FULL STEP DISPENSE (μL)	MAXIMUM DISCHARGE PRESSURE (psig)	
LPVA1725325D	250	PMMA	0.2	45	
LPVA1755325D		PEEK			
LPVA1725350D	500	PMMA	0.47	30	
LPVA1755350D		PEEK			
LPVA1725310H	1000	PMMA	0.4	30	
LPVA1755310H		PEEK			
LPVA1725330H	3000	PMMA	1	30	
LPVA1755330H		PEEK			

LPV Series High Performance – Dual Seal

J

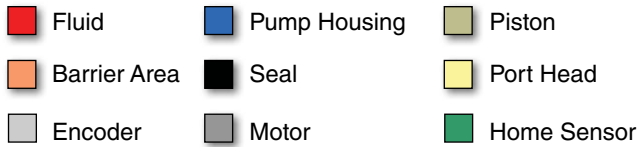
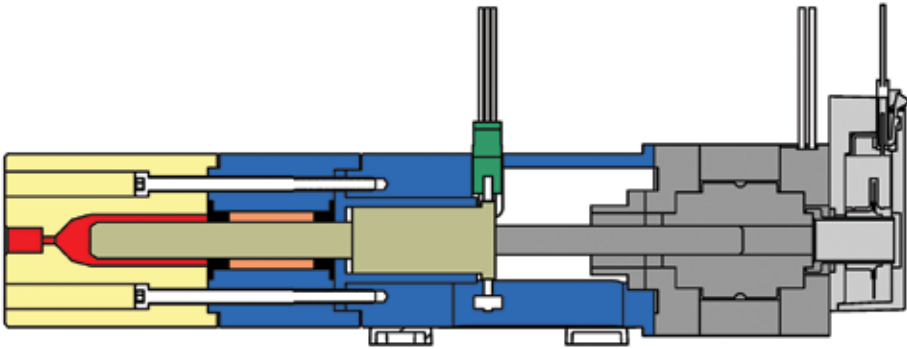

- Wetted Materials:
 - Pump chamber: Port Head (see chart below), TZP, UHMW PE
 - Flush chamber: TZP, UHMW PE, PEEK, 316 SS
- External valving required
- Encoder and home sensor equipped
- Motor: Bipolar
- Power: 400-420 mA / phase

	CV% (10% Dispensed Volume)	CV% (Full Dispensed Volume)	MAX. SPEED HALF STEPS (pps)	LENGTH "L"
	0.5% (@25 µL)	0.05% (@250 µL)	4000	5.54" (140.7 mm)
	0.5% (@50 µL)	0.05% (@500 µL)	4000	5.87" (149.1 mm)
	0.5% (@100 µL)	0.05% (@1000 µL)	4000	7.24" (183.9 mm)
	0.5% (@300 µL)	0.05% (@3000 µL)	4000	7.86" (199.6 mm)

GENERAL SPECIFICATIONS

The following specifications apply to all LPV Series pumps, unless otherwise noted.

Cycle Life

The LPV pumps will operate for a minimum of 5 million cycles on clean water. Chemical content of the fluid and other factors such as particulate matter and dissolved salts will affect the life.

Operating Pressure

LPV pumps are self priming. Typically, the pumps will operate as low as -10 psi on the inlet. This lower limit will be affected by the fluid being pumped. Discharge pressures for specific models are listed with the specific part number.

Operating Temperature

Maximum operating temperature is 150°F (66°C).

Operating Speed

- Refer to the Pump Selection Charts for the maximum operating speed (listed in half steps) for specific models.
- For maximum acceleration rates, ramp rates and harmonic ranges, contact The Lee Company for individual drawings.
- Pumps may be operated in full step, half step and micro step mode, depending on the capability of the drive electronics and the application requirements.

Port Connections

- All pumps use 1/4-28 flat bottom ports (inlet and outlet).
- Custom port head options are available for OEM applications.

Valving

LPV pumps require inlet and outlet valving.

Pump Mounting

LPVA15 and LPVA17 Series surface mount pumps (port head style) require #4 (3 mm) screws. LPVA10 Series utilize #4 (2.5 mm) screws. The screw length must be sufficient to allow proper engagement in the mounting surface. Manifold mount pumps require a properly machined boss. A detailed machining drawing is available for all of the manifold mounted models (see Pump Selection Charts).

Electrical Characteristics

- All motors are 2 phase bipolar.
- Pumps supplied with encoders use 2 channel, quadrature encoders. These are 1 step per pulse (no index pulse supplied).

Drive Electronics

Lee offers a pump driver kit for application development, Part Number LSKX0502150C. This includes the electronics to drive any of the LPV series pumps and the required valving (one 3-way valve or two 2-way valves)*. The unit is based on an AllMotion Inc. stepper drive, which can later be incorporated into production hardware if needed.

* Pump and valves are not included in kit.

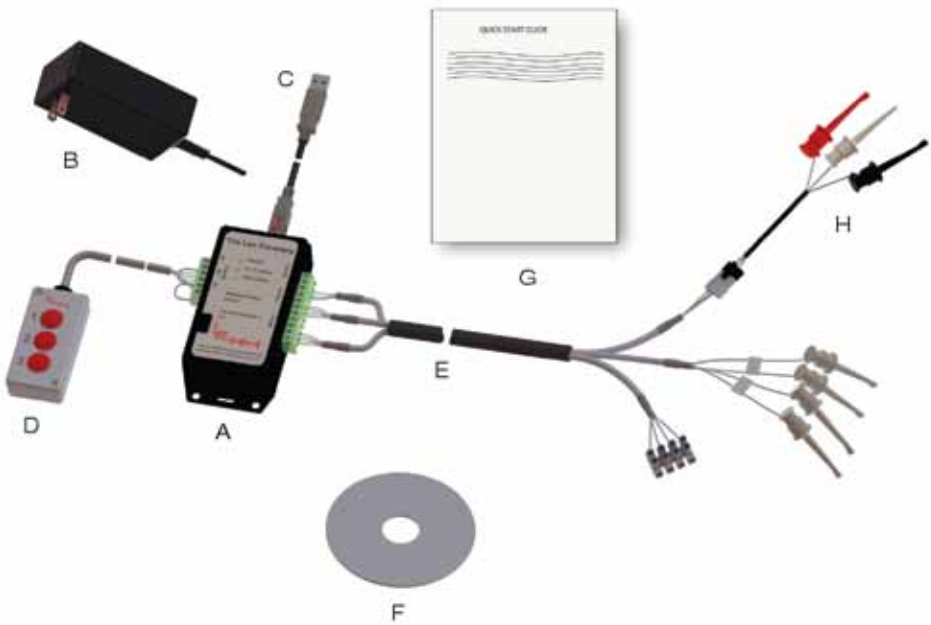

- A – Stepper Pump Driver
- B – Power Supply
- C – USB Cable
- D – Three Button Switch Box
- E – Extension Cable
- F – Installation CD
- G – Quick Start Guide
- H – Home Sensor Adapter Cable

Manifold Technology

The Lee Company Electro-Fluidic Systems Group has been an industry leader in electro-mechanical valve and pump technology for over three decades. Manifolds offer several advantages compared to just tubing together discrete components, such as fewer leakage points, lower internal volumes, easier assembly into the instrument, and higher reliability. Our expertise in fluidics is drawn from a solid understanding of the application and the components involved. We can incorporate solenoid valves, pumps, passive components (i.e. restrictors) and active components (i.e. transducers) into a complete assembly that has been functionally tested per the application requirements. The different manufacturing techniques used to create such manifolds include conventional, multi-layered and ant farm.



Conventional Manifold Technique

The conventional approach to machining a manifold is typically used when the valve count is minimal and the flow paths are straightforward. The design pattern of drilled passages enables you to locate valves as desired, with some limitations because the drilled passages must be straight and it requires the plugging of superfluous construction passageways. Integrating miniature valves into a common fluid manifold using conventional cross-drilled machining is a major step in the direction of simplifying otherwise complex valve and fluid passage configurations that once required numerous tubes from point to point.

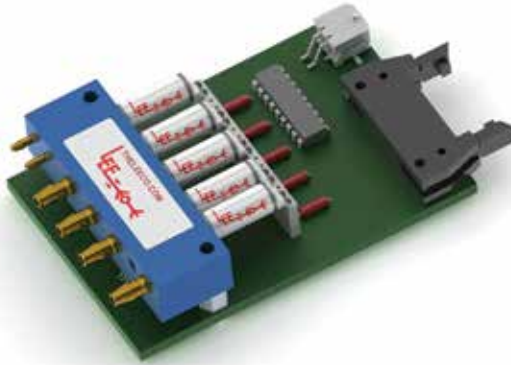

The image above illustrates a conventional manifold design populated with LHD Series solenoid valves (Plug-In Style) mounted onto a printed circuit board. Equipped with barb ports to accommodate soft tube connection, the subsystem can be easily integrated into any unit.

Multi-Layered Manifold Technique

A multi-layered manifold is typically used when the functional requirements are more complex, which usually involves a higher valve count. This type of manifold design involves stacking together multiple layers of plates containing different machined or milled passages. The different plates are then bonded (epoxy, diffusion or solvent weld) together which allows the valves, pumps, and other fluidic sub-components to be located where appropriate for a specific application.



The image above shows a multi-layered manifold design populated with LFV Series solenoid valves.

Ant Farm Manifold Technique

The Ant Farm Technique involves machining a series of intricate flow paths or channels into the face of the manifold. After the machining operation, a plate is bonded over the flow passages to complete the circuit. In complex applications, the channels can be milled into more than one face of the manifold block. This manifold machining technique further reduces the overall manifold size compared to the other technologies.

K

This technology also lends itself towards building a modular design. The modular design includes provisions in the near fluid passage for O-rings to provide a seal between different sections of the manifold when mounted together. This erector-set approach to manifold construction gives the designer more flexibility, especially if the application requires a distribution plate to redirect or prevent flow from one passage to another between sections. It also allows the designer to use a spacer plate to increase dimensions between sections when an oversized component or obstruction must be accommodated on the mounting surface.

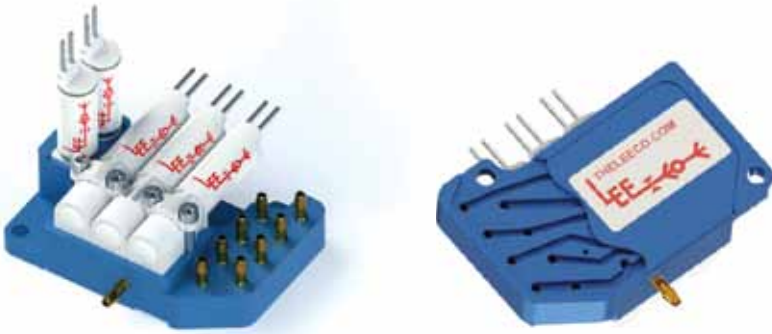

This manifold design capitalizes on the use of our Ant Farm Technique integrating multiple styles of LHD Series valves (plug-in and face mount) in order to accommodate a system's specific space constraints and flow schematic requirements. The intricate flow paths that complete the internal circuit are showcased in the image on the right, where the bond plate has been partially cut away.

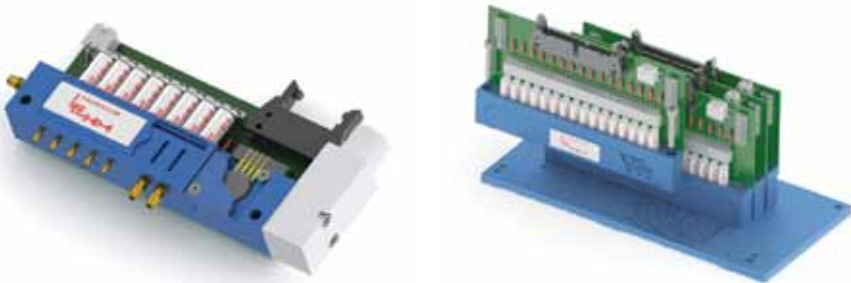

This manifold design exemplifies a higher degree of capability using our Ant Farm Technique together with several LHD Series solenoid valves and other critical components (pressure transducer and regulator).

This complex manifold design demonstrates taking a modular approach while also employing our Ant Farm Technique. Four valve modules are mounted onto a distribution plate and o-rings with integrated screens are used to ensure a proper seal between the different manifold sections.

Combination Manifold Technique

Combination manifolds are used to incorporate discrete components into a single unit. The Lee LPV Series pumps have a large machined port head. Customization of this port head can incorporate solenoid valves, connections and sensors into a single package. This technique reduces the number of connections, the need for a second manifold and the overall package size. Combining several discrete components into a single one also reduces assembly time during instrument production.



This manifold design demonstrates another level of capability where LHD Series solenoid valves can be integrated into an LPV Series pump with a custom port head.

Injection Manifold Technique

Lee injection valves minimize the fluid between the valve seat and the flow stream. This in turn minimizes carry over volumes. Staggering the valves on a multi-face manifold allows closer spacing and further reduces the length (thus volume) of the main flow passage.

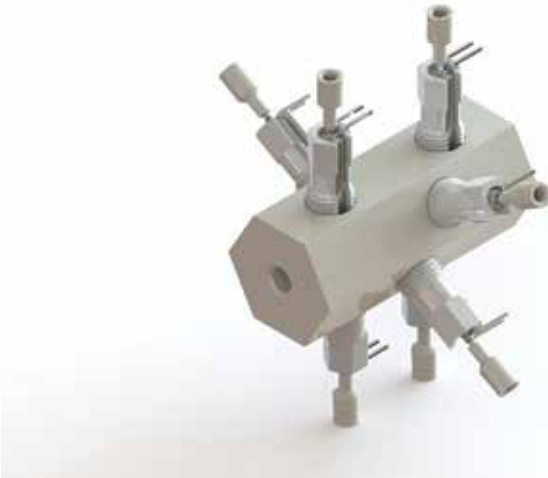

The image above illustrates the use of our VHS Series solenoid valves in a custom manifold design.

Manifold Materials

The following is a list of typical materials used for each technology. Other materials may also be available.

- Conventional:
 - Stainless Steel
 - Aluminum (Anodized)
 - PMMA
 - PEEK
 - Ultem
- Multi-Layered:
 - Aluminum (Anodized)
 - PMMA
- Ant Farm:
 - Aluminum (anodized for increased corrosion resistance)
- 3-D Printing STL: This allows quick turnaround of proof of principle parts without having to commit to the cost of hard tooling.
- Other materials are available. Contact The Lee Company for technical assistance.

Manifold Assembly

Manifolds are typically outfitted with inlet and outlet ports. These ports can be brass barbs, stainless steel hypo tubes, 1/4-28, M6 or any other port that is needed. To prevent contamination from rogue particles, it is standard Lee Company practice to screen all ports when space permits. The finished manifold is then populated with subcomponents. Once the manifold is fully assembled, it is tested to comply with specific application parameters to reduce installation time and eliminate start-up problems. After successfully passing all tests and certified clean, the ports are sealed to prevent any contamination during subsequent transit or handling.

Manifold Advantages

There are many advantages for using a manifold system, such as:

- Custom designed, manufactured, and 100% tested from a single source
- Reduced assembly & installation costs
- Space & weight savings
- Manifold mountable components:
 - Solenoid valves
 - Pumps
 - Components (restrictors, filters, check valves)
 - Single fluid fittings and gang interface connections
- Integrated electrical components (pressure sensors, connectors, circuit boards)
- Warranted as a single part number
- Maintenance and repair service available

Contact The Lee Company for additional technical assistance and application information.

NOTES

K

MINSTAC, The Lee Company's Miniature Inert System of Tubing and Components, offers the ability to precisely control flow rate, pressure, filtration and other performance factors of aggressive fluids.

Tube Fittings

062 MINSTAC	L5-12
125 MINSTAC	L13-20
156 MINSTAC	L21-30
1/4-28 Flat Bottom	L31-32
Line Seal Caps	L33
Boss Plugs.....	L34
Manifolds – 3 Boss	L35
Manifolds – 5 Boss	L36
Adapters.....	L37-44
Unions.....	L45-46

Fluid Control Components

Check Valves	L48
Filters	L49-51
Safety Screens.....	L52-53
Stock Tubing.....	L54
Starter / Tool Kits.....	L55-56

Lee MINSTAC Tubing End Connections

The basis of the Lee MINSTAC System is the unique Collet-Lock system, which allows the chamfering of Teflon® tubing, and threading a specially designed Collet onto its end. This assembly provides a leak-proof connection from Teflon® tubing to the wide range of MINSTAC components and fittings, all without the problems associated with Teflon's® cold flow characteristics.

Standard tubing assemblies are available from stock with one or two fitting ends installed. Special lengths and fitting assembly tool kits are also available. Please request T.R. 062 for complete assembly instructions and tool kit part numbers.

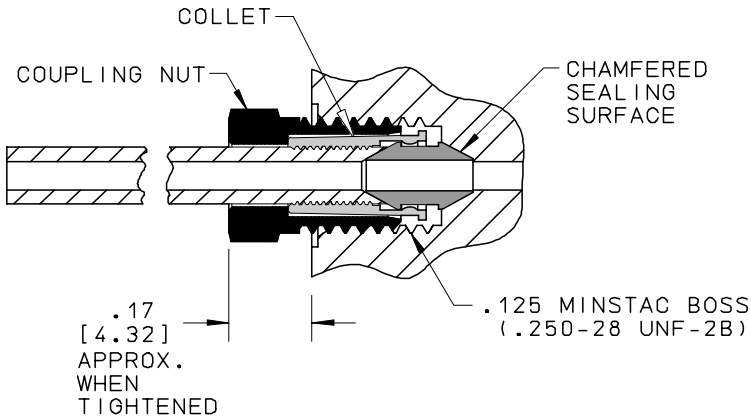

The standard tubing connection sizes described below are available with a variety of inner diameters, and are capable of satisfying most fluid handling requirements.

062 MINSTAC

The 062 MINSTAC fitting system is for use with 0.062" (1.57 mm) O.D. Teflon® tubing and uses a 0.138-40 UNF fitting end. This system utilizes an internally threaded Collet that grips the outer diameter of the Teflon® tubing end, preventing cold flow. The Coupling Screw acts like a compression fitting and presses the chamfered end of the tubing against one end of the KEL-F® Ferrule. The other end of the Ferrule is pressed against the sealing surface in the boss by the Coupling Screw. This self-aligning fitting provides the smallest most reliable leak proof system on the market today.

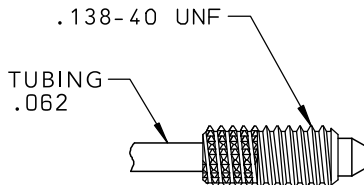

Unless otherwise specified, dimensions are in inches [mm].

125 MINSTAC

The 125 MINSTAC fitting system uses 0.125" (3.18 mm) O.D. Teflon® tubing and a 0.25-28 UNF fitting end. The MINSTAC system utilizes an internally threaded Collet sleeve that grips the outer diameter of the Teflon® tubing end, preventing cold flow. The chamfered end of the tubing is pressed against one end of the Ferrule by the Collet. The other end is pressed against the sealing surface in the boss by the Coupling Screw.

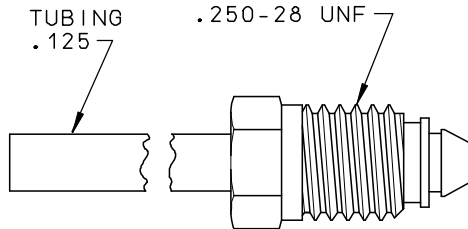

156 MINSTAC

The 156 MINSTAC fitting system is for use with 0.156" (3.96 mm) O.D. Teflon® tubing and uses a 0.25-28 UNF fitting end. This system utilizes an internally threaded Collet sleeve that grips the outer diameter of the Teflon® tubing end, preventing cold flow. The chamfered end of the tubing is pressed against one end of the Ferrule by the Collet. The other end is pressed against the sealing surface in the boss by the Coupling Screw.

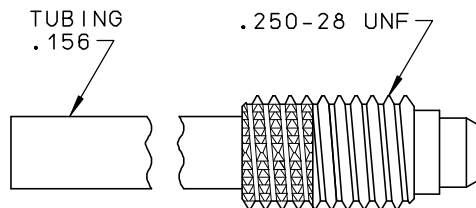

Unless otherwise specified, dimensions are in inches [mm].

062 Boss Configuration

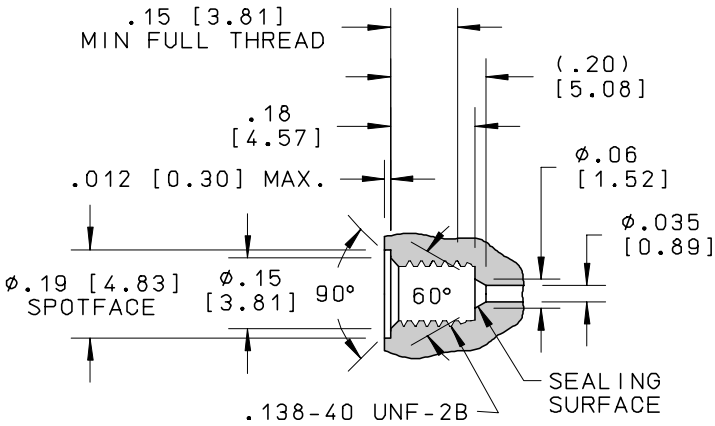

Boss Drawing TMIX1300000A

Unless otherwise specified, dimensions are in inches [mm].

062 Fitting Assembly

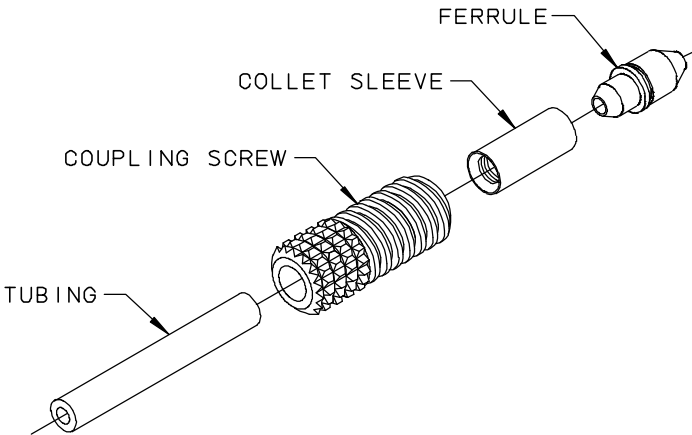

Anodized Aluminum	Coupling Screw: TMAA320207 <input type="checkbox"/> Z *color code _____
303 Stainless	Collet Sleeve: TMCA3202030Z
PCTFE	Ferrule: TMBA3202910Z

* Color Code: 0 - Black; 1 - Brown; 2 - Red; 3 - Orange; 4 - Yellow; 5 - Green; 6 - Blue; 7 - Violet; 8 - Gray; 9 - Clear

TEFLON® TUBING PART NUMBER INFORMATION

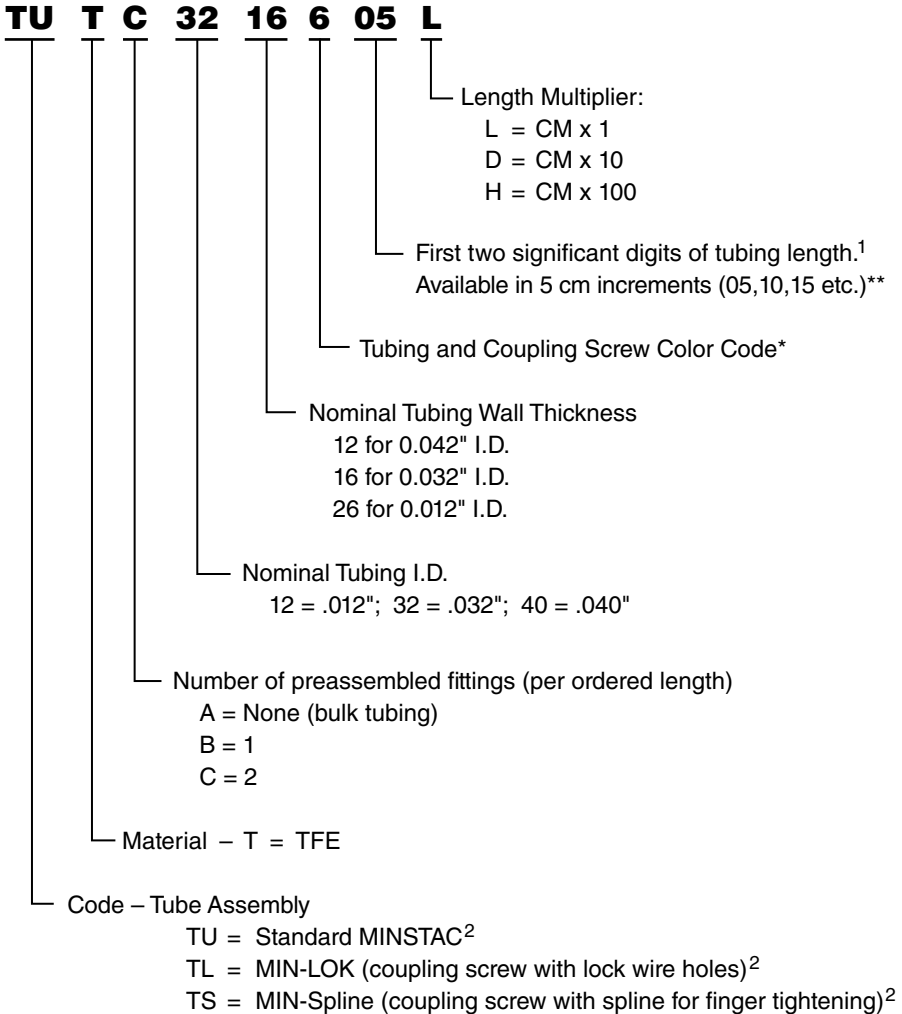

(1.) See [page L54](#) for available stock lengths.

(2.) See [page L7](#) for styles.

* Color Code: 0-Black; 1-Brown; 2-Red; 3-Orange; 4-Yellow; 5-Green; 6-Blue; 7-Violet; 8-Gray; 9-Clear

** Bulk tubing is only available in 300 cm (30D) and 3,000 cm (30H) lengths.

062 MINSTAC Tubing Assembly Styles

Standard MINSTAC – smallest package

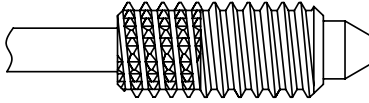

“MIN-Spline” – larger coupling screw for hand tightened installations

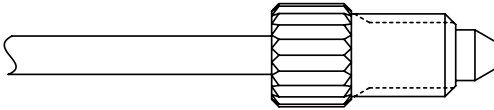

“MIN-LOK” – MINSTAC coupling screw with lock wire holes for high vibration applications

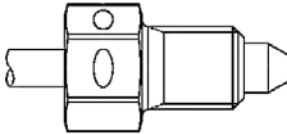

062 MINSTAC Tubing Assembly

MINSTAC Tubing Assemblies are available in pre-made assemblies (see [page L54](#) for standard lengths). Special lengths and configurations are available for OEM applications.

Fittings are also available in tubing and tool kits for prototype and lab work.

062 MINSTAC Boss Preparation

The fitting boss required for the 062 MINSTAC coupling may be produced with the Lee Combination Drill Part Number TTTA3200643A. The drill was designed for use in plastics and soft metals. It produces a boss (excluding the threads) with the proper configuration and dimensions. The boss may be produced as follows:

Boss Preparation Tools

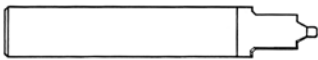

Combination Boss Drill: TTTA3200643A

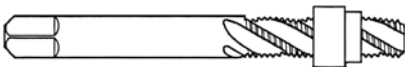

Plug Tap: TTTA3200743A



Bottoming Tap: TTTA3200843A

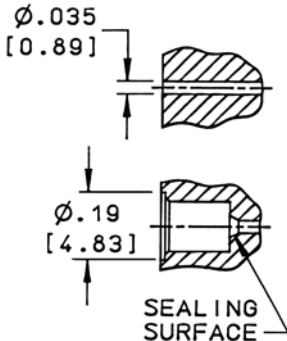

Procedure:

1. Drill a 0.035" (0.89 mm) diameter pilot hole in the desired boss location.
2. Insert the front of the Lee Combination Boss Drill Part Number TTTA3200643A into the pilot hole and drill down until the 0.187" (4.75 mm) diameter spotface cleans up the surface of the boss. All diameters should be concentric within 0.006" (0.15 mm) T.I.R. The sealing surface should be smooth with no burrs or tool marks.

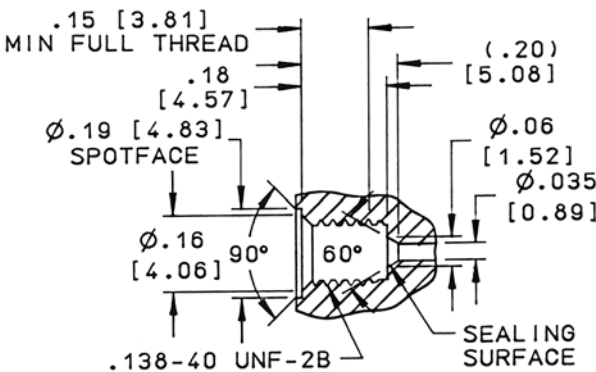

3. Tap the 0.138-40 unfinished threads using the Lee Plug Tap Part Number TTTA3200743A first and the Lee Bottoming Tap Part Number TTTA3200843A second. These taps incorporate stops to avoid damaging the sealing surface. The boss is now complete.

NOTE: Care must be taken to ensure that the taps will follow true in hole produced by the Combination Drill.

Unless otherwise specified, dimensions are in inches [mm].



062 MINSTAC Tubing Preparation and Coupling Assembly

Coupling Assembly Tools

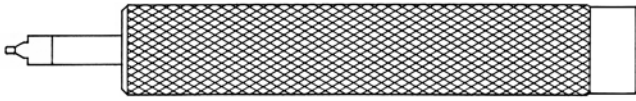

Chamfer Tool
TTTA3201543A

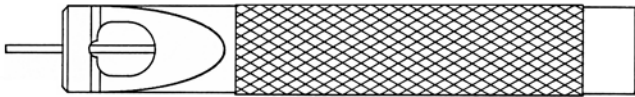

Collet Tool*
TTTA3201443A

Procedure:

1. Cut the tubing to the desired length. The cut should be reasonably square.
2. Slide the Coupling Screw (Part Number TMAA320207_Z) over the end of the tubing, with the threaded end facing the tubing end. Place the collet into Tool* (Part Number TTTA3201443A) counterbore end first.

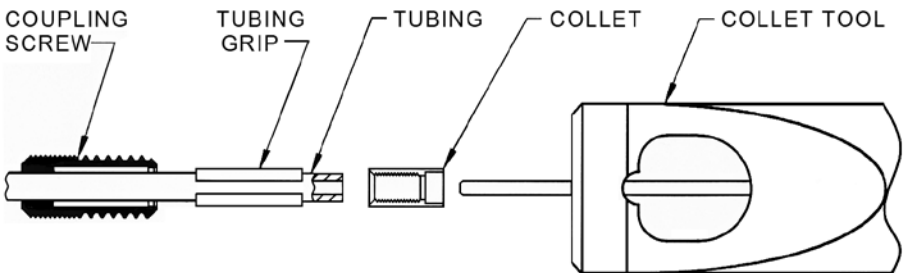

* The Lee Collet Tool (Part Number TTTA3201443A) is for use with 0.032" (0.81 mm) I.D. tubing. The following tools should be substituted for use with their respective sized tubing:

TTTA3201743A: 0.012" (0.30 mm) I.D. tubing

TTTA4000143A: 0.040" (1.02 mm) I.D. tubing

Procedure continued:

3. While holding the tubing with the rubber Tubing Grip (Part Number TTTX0500900A), screw the Collet onto the tubing end. This should require about 15-20 turns of the Collet Tool. Remove the tool from the coupling end and check that the tubing extends at least to the end of the collet.

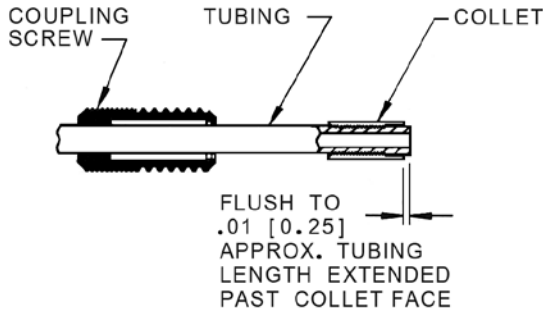

4. Using the Lee Chamfering Tool* (Part Number TTTA3201543A), place the pilot pin into the tubing assembly. Rotate the tool while applying a small axial force in a clockwise direction until it bottoms out against the Collet (already installed on the tubing).

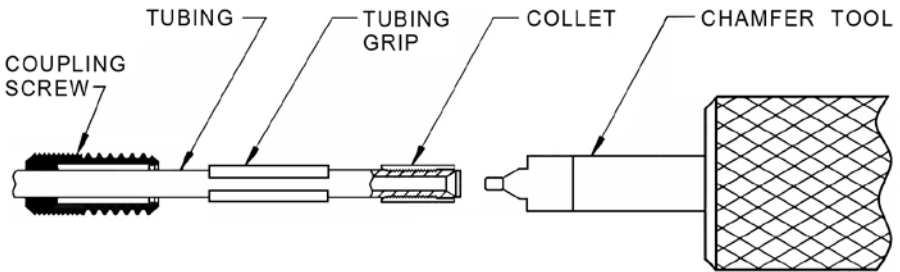

* The Chamfer Tool (Part Number TTTA3201543A) is for use with 0.032" (0.81 mm) I.D. tubing. The following tools should be substituted for use with their respective sized tubing:

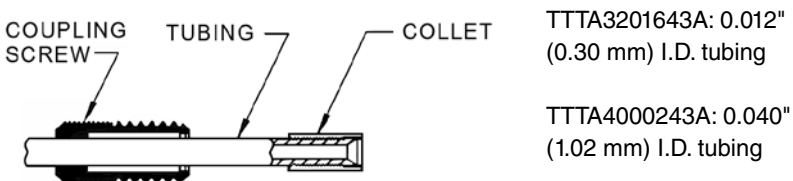

5. Slide the Coupling Screw over the Collet.

Unless otherwise specified, dimensions are in inches [mm].



Procedure continued:

6. Push the Ferrule (Part Number TMBA3202910Z) onto the Ferrule installation end of the Lee Chamfer Tool (Part Number TTTA3201543A).

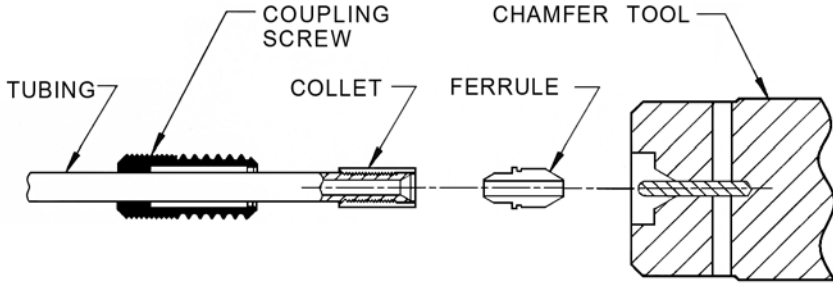

7. While holding the Coupling Screw, insert the Ferrule into the Coupling Screw (approx. 4 lbs. (1.8 kg.) force is required). The Ferrule will "snap" in place. The coupling assembly is now complete.

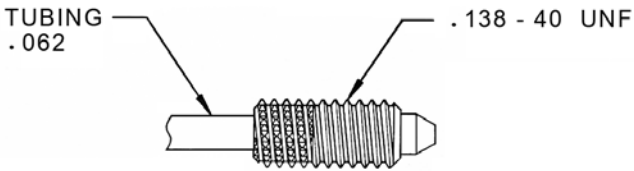

062 MINSTAC Coupling Installation

Coupling Installation Tools



Torque Wrench
TTTA3201243A



Wrench
TTTA3200543C

Unless otherwise specified, dimensions are in inches [mm].

Procedure:

1. Start threading coupling assembly into the 062 MINSTAC fitting boss by hand.

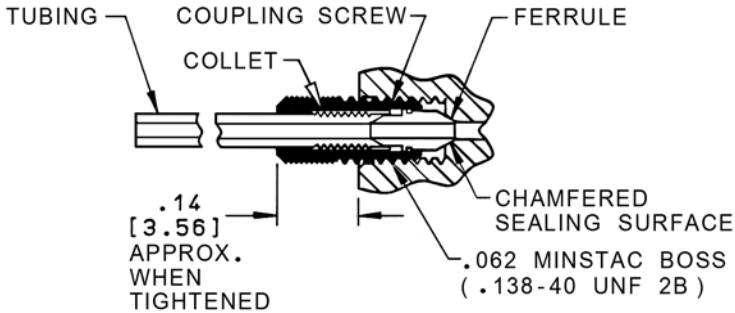

2. Tighten the fitting between 5 to 10 ozf•in (0.035 to 0.07 N-m) by slipping the Lee Torque Wrench (Part Number TTTA3201243A) onto the knurled Coupling Screw. The minimum torque is achieved by pressing the shorter torque arm clockwise until it just contacts the longer arm. To check that maximum recommended torque is not exceeded, invert the Torque Wrench and press the longer torque arm clockwise until the Coupling Screw begins to move. This should occur before the torque arms make contact. After gaining a feel for the proper torque, use of the Torque Wrench may be discontinued.

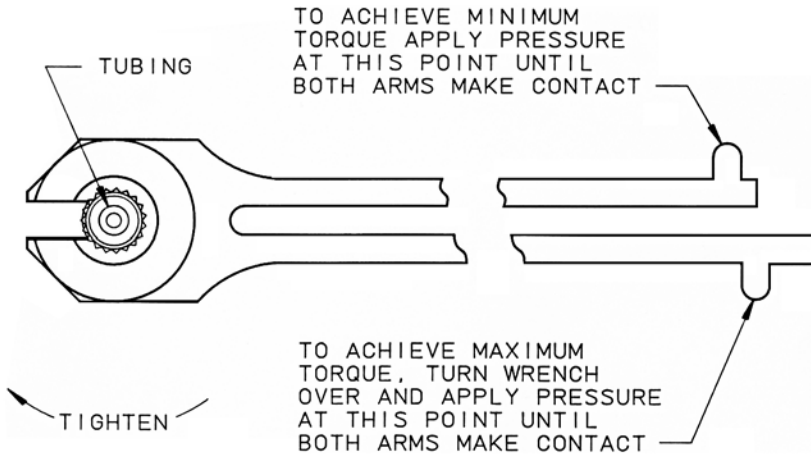

Note: Minimum recommended torque: 5 ozf•in (0.035 N-m)
Maximum recommended torque: 10 ozf•in (0.07 N-m)

Unless otherwise specified, dimensions are in inches [mm].

125 Boss Configuration

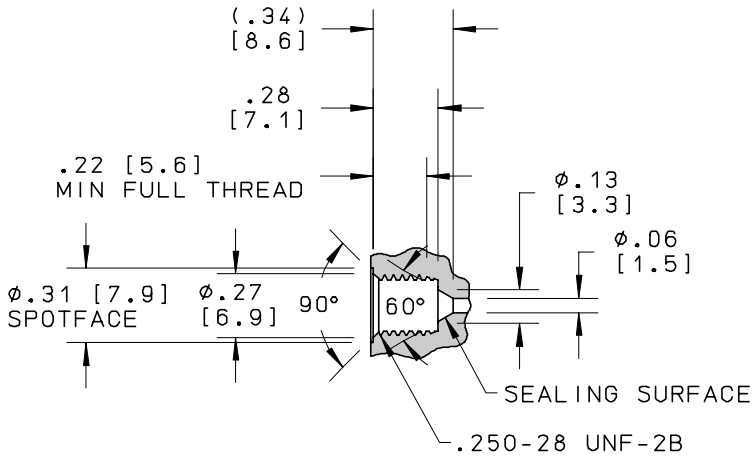

Boss Drawing TMIX5000000A

Unless otherwise specified, dimensions are in inches [mm].

125 Fitting Assembly

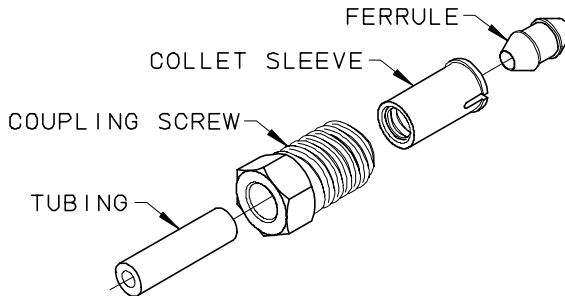

Valox®	Coupling Screw: TMAA6201929Z
Valox®	Collet Sleeve: TMCA6201920Z
PCTFE	Ferrule: TMBA6201910Z

TEFLON® TUBING PART NUMBERING INFORMATION

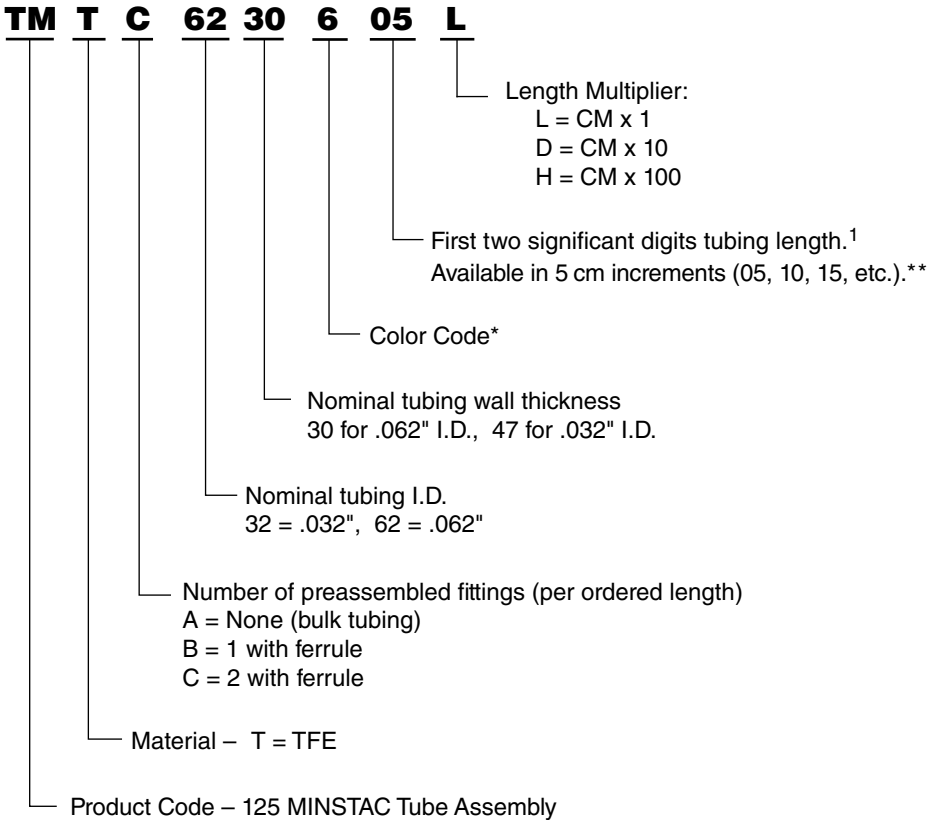

(1.) See [page L54](#) for available stock lengths.

* Color Code: 0-Black; 1-Brown; 2-Red; 3-Orange; 4-Yellow; 5-Green; 6-Blue; 7-Violet; 8-Gray; 9-Clear

** Bulk tubing (TUTA) is only available in 300 cm (30D) and 3,000 cm (30H) lengths.

125 MINSTAC Boss Preparation

Boss Preparation Tools

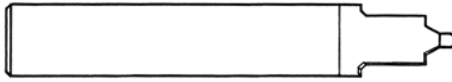

Combination Boss Drill
TTTA6201927A

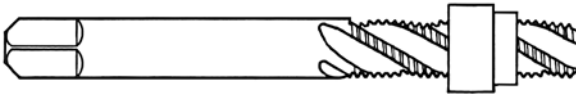

Plug Tap
TTTA6201627A



Bottoming Tap
TTTA6201727A

Procedure:

1. Drill a 0.062" (1.67 mm) diameter pilot hole in the desired boss location.
2. Insert the front of the Lee Combination Boss Drill (Part Number TTTA6201927A) into the pilot hole and drill down until the 0.312" (7.90 mm) diameter spotface cleans up the surface of the boss. All diameters should be concentric within .006" (0.15 mm) T.I.R. The sealing face should be smooth with no burrs or tool marks.
3. Tap the 0.250-28 unfinished threads using the Lee Plug Tap (Part Number TTTA6201627A) first and the Lee Bottoming Tap (Part Number TTTA6201727A) second. These taps incorporate stops to avoid damaging the sealing surface.

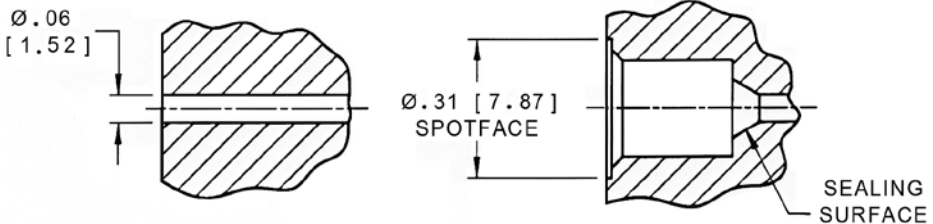

Unless otherwise specified, dimensions are in inches [mm].

NOTE: Care must be taken to ensure that the taps will follow true in hole produced by the Combination Drill.

125 MINSTAC Tubing Preparation and Coupling Assembly

Coupling Assembly Tools

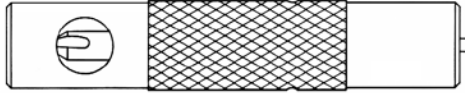

125 MINSTAC TTTA6200143A *

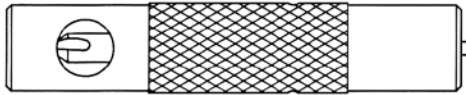

125 MINSTAC TTTA6200343 (no ferrule) *

Procedure:

1. Assembly instructions for use with 125 MINSTAC Bosses.
 - a. Cut the tubing reasonably square to the desired length.
 - b. Hold tubing with Tubing Grip. Slide the center drill end of Lee Coupling Assembly Tool* (Part Number TTTA6200143A) onto tubing. Hand twist the tool clockwise to form a chamfered lip seal. The resulting chamfer should leave a 0.002" to 0.004" (0.05 mm to 0.10 mm) flat on the end of the tube.

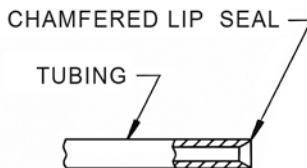
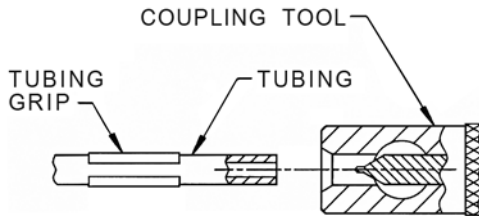

- * Use the Lee Coupling Assembly Tool (Part Number TTTA6200143A) for use with 0.062" (1.57 mm) I.D. tubing. Substitute the Lee Coupling Assembly Tool (Part Number TTTA6200243A) for use with 0.032" (0.81 mm) I.D. tubing.

Procedure continued:

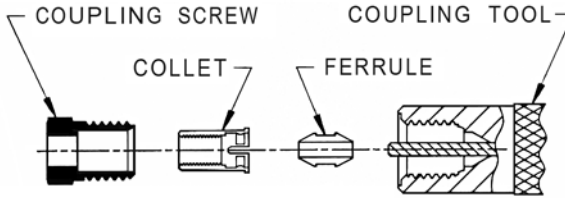

- c. Slip the Ferrule (Part Number TMBA6201910Z) onto pin of the Coupling Assembly Tool. (See [page L40](#) for 1/4-28 Flat Bottom Ferrule).
- d. Slide the flanged end of Collet Sleeve (Part Number TMCA6201920Z) over the Ferrule until it snaps in place.

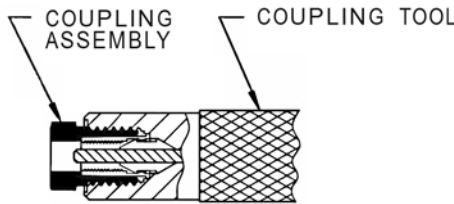

- e. Thread the Coupling Screw (Part Number TMAA6201929Z) over the Collet Sleeve until it bottoms.

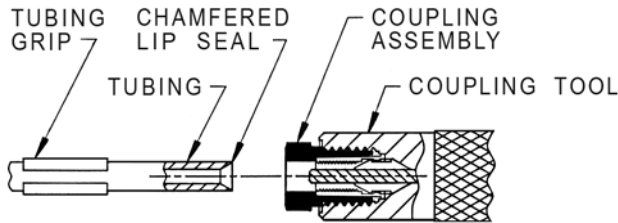

- f. Thread the tool/coupling assembly counterclockwise onto the chamfered tubing using the Tubing Grip, applying slight force until resistance is felt after approximately 5 turns.

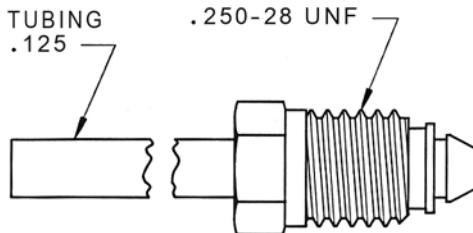

- g. Unscrew the coupling from tool. The assembly is now ready for installation into a 125 MINSTAC boss.

125 MINSTAC Coupling Installation

Coupling Installation Tools

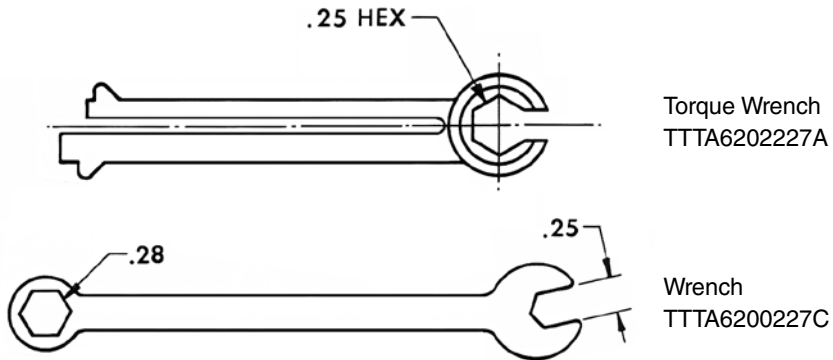

Procedure:

1. Start threading the coupling assembly into a 125 MINSTAC boss using Lee Wrench (Part Number TTTA6200227C).
2. Tighten the fitting between 7 to 21 ozf•in (0.05 to 0.15 N-m) by slipping the Lee Torque Wrench (Part Number TTTA6202227A) onto the Coupling Screw hex. The minimum torque is achieved by pressing the shorter torque arm clockwise until it just contacts the longer arm. To check that maximum recommended torque is not exceeded, invert the Torque Wrench and press the longer torque arm clockwise until the Coupling Screw begins to move. This should occur before the torque arms make contact. After gaining a feel for the proper torque, use of the Torque Wrench may be discontinued.

Procedure continued:

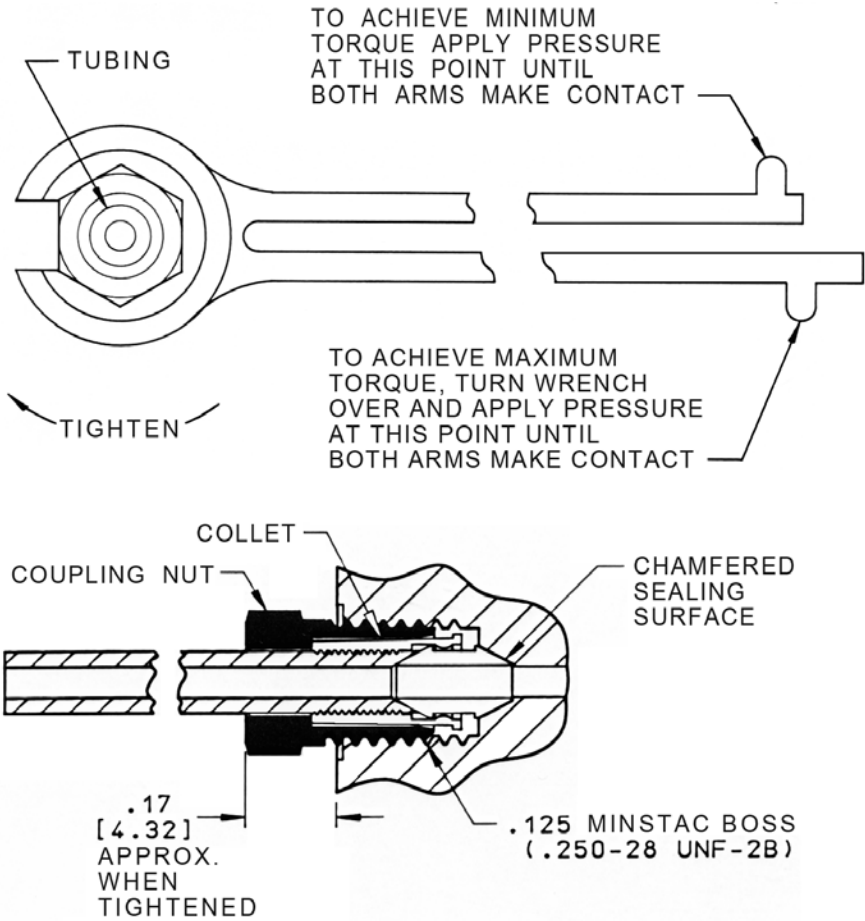

NOTE: Minimum recommended torque: 7 ozf•in (0.05 N•m)
Maximum recommended torque: 21 ozf•in (0.15 N•m)

Unless otherwise specified, dimensions are in inches [mm].

NOTES

156 Boss Configuration

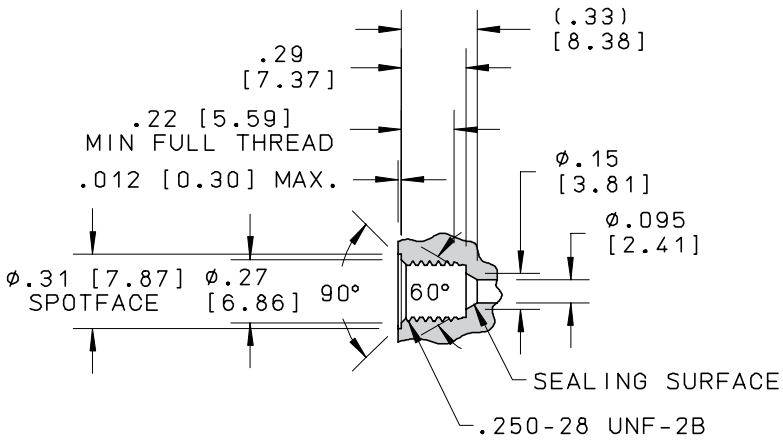

Boss Drawing TMIX9000000A

Unless otherwise specified, dimensions are in inches [mm].

156 Fitting Assembly

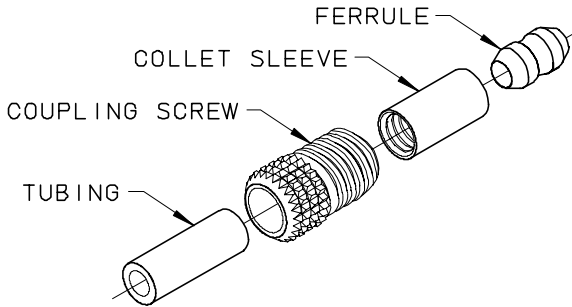

Anodized Aluminum	Coupling Screw: TMAA950107 <input type="checkbox"/> Z *color code _____
PEEK	Collet Sleeve: TMCA9501950Z
PCTFE	Ferrule: TMBA9501910Z

* Color Code: 0 - Black; 1 - Brown; 2 - Red; 3 - Orange; 4 - Yellow; 5 - Green; 6 - Blue; 7 - Violet; 8 - Gray; 9 - Clear

TEFLON® TUBING PART NUMBERING INFORMATION

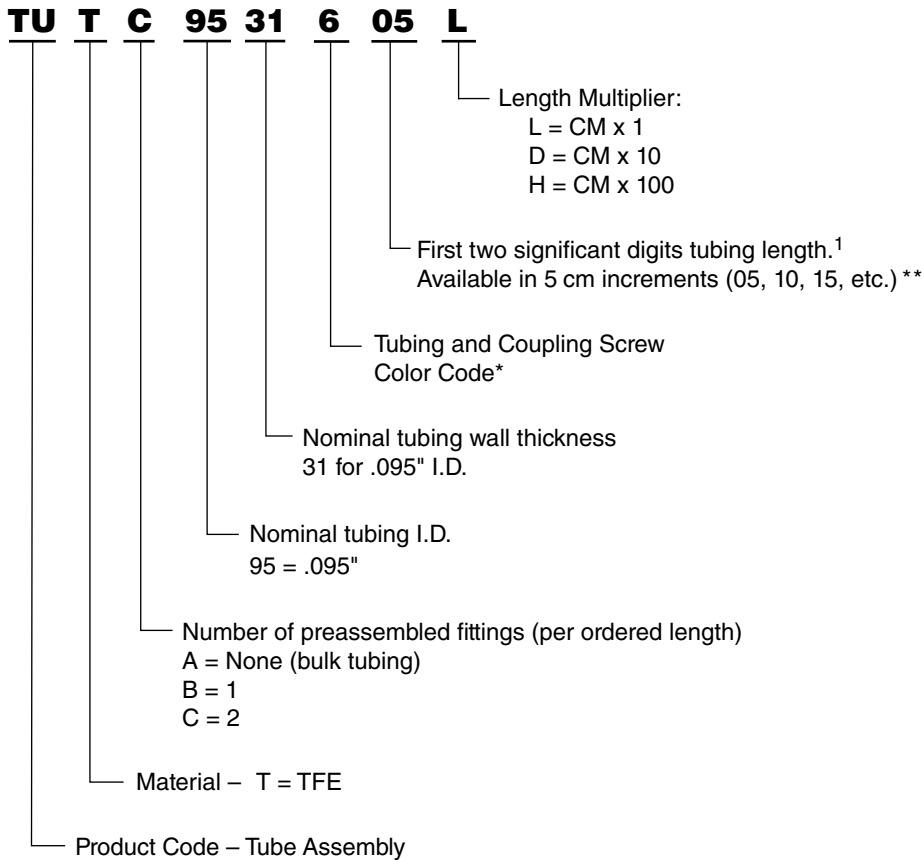

(1.) See [page L54](#) for available stock lengths.

* Color Code: 0-Black; 1-Brown; 2-Red; 3-Orange; 4-Yellow; 5-Green; 6-Blue; 7-Violet; 8-Gray; 9-Clear

** Bulk tubing is only available in 300 cm (30D) and 3,000 cm (30H) lengths.

156 MINSTAC Boss Preparation

Boss Preparation Tools

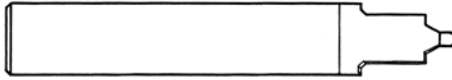

Combination Boss Drill
TTTA9500227A

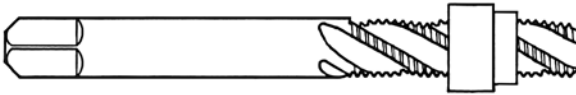

Plug Tap
TTTA6201627A



Bottoming Tap
TTTA6201727A

Procedure:

1. Drill a 0.096" (2.44 mm) diameter pilot hole in the desired boss location.

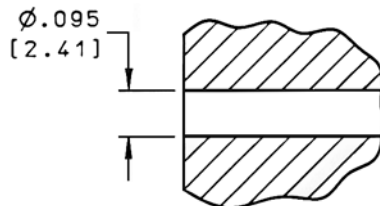

Unless otherwise specified, dimensions are in inches [mm].

Procedure continued:

2. Insert the front of the Lee Combination Boss Drill (Part Number TTTA9500227A) into the pilot hole and drill down until the 0.311" (7.90 mm) diameter spotface cleans up the surface of the boss. All diameters should be concentric within 0.006" (0.15 mm) T.I.R. The sealing surface should be smooth with no burrs or tool marks.

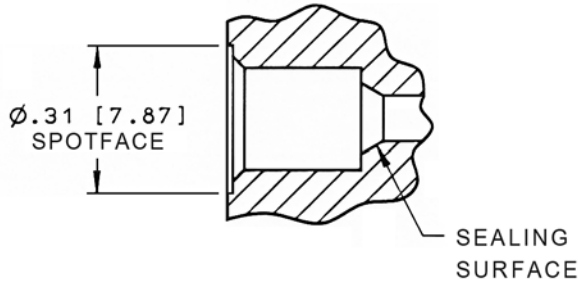

3. Tap the 0.250-28 unfinished threads using the Lee Plug Tap (Part Number TTTA6201627A) first and the Lee Bottoming Tap (Part Number TTTA6201727A) second. These taps incorporate stops to avoid damaging the sealing surface.

NOTE: Care must be taken to ensure that the Taps will follow true in the hole produced by the Combination Drill.

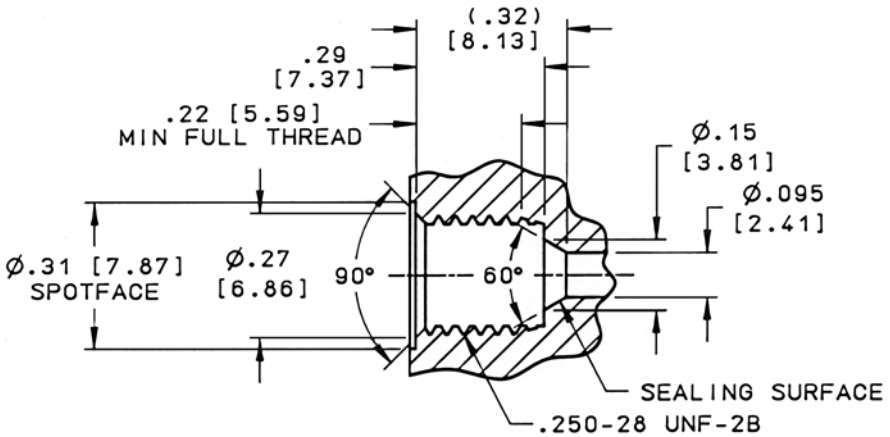

Unless otherwise specified, dimensions are in inches [mm].

156 MINSTAC Tubing Preparation and Coupling Assembly

Tubing Preparation and Coupling Assembly Tools

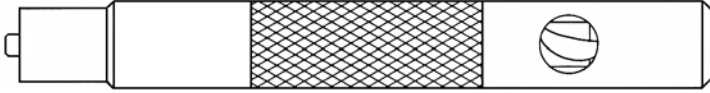

Coupling Assembly Tool TTTA9500127A

L

Procedure:

1. Cut the tubing reasonably square to the desired length.

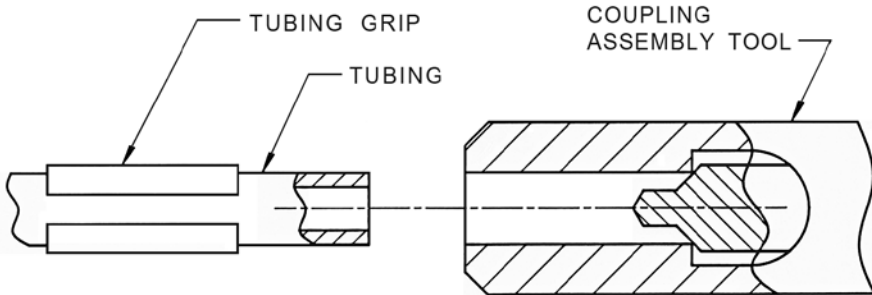

2. Hold the tubing with the Tubing Grip. Slide the center drill end of Lee Coupling Assembly Tool (Part Number TTTA9500127A) onto the tubing. Hand twist the tool clockwise to form a chamfered lip seal. The resulting chamfer should extend to the O.D. of the tubing.

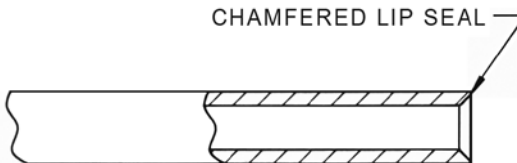

Procedure continued:

- 3 Slip the Ferrule (Part Number TMBA9501910Z) onto pin of the Coupling Assembly Tool. (See page L40 for 1/4-28 Flat Bottom Ferrule).

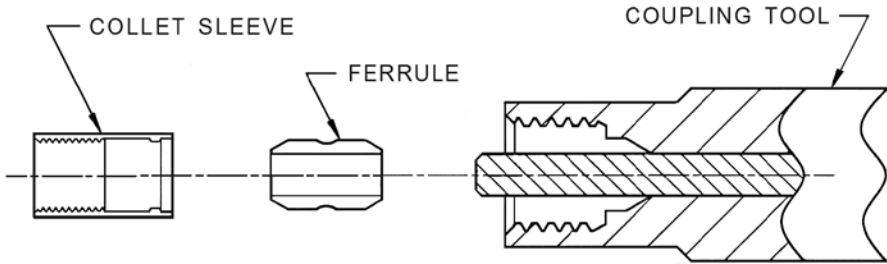

4. Slide internally unthreaded end of the Collet Sleeve (Part Number TMCA9501950Z) over the Ferrule until it snaps in place.

NOTE: Collet should protrude approximately 0.10" (2.5 mm) from tool end).

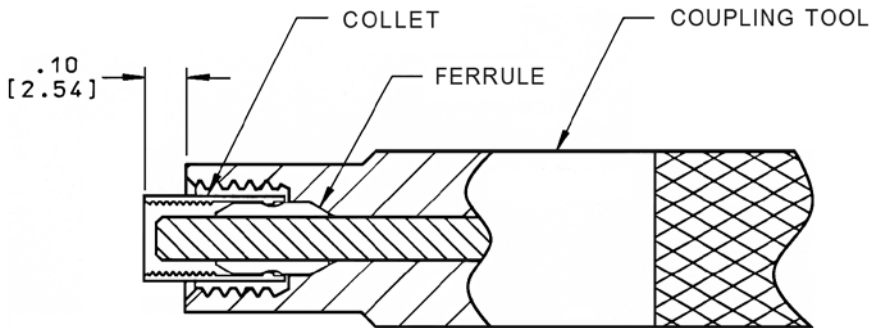

5. Thread the Coupling Screw (Part Number TMAA9501079Z) over the Collet Sleeve until it bottoms on the Collet Sleeve.

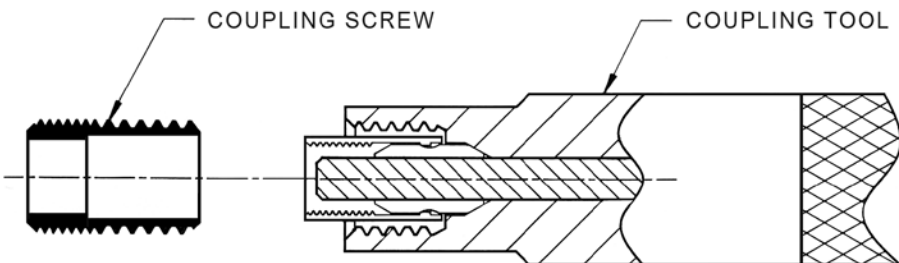

Unless otherwise specified, dimensions are in inches [mm].



Procedure continued:

NOTE: The Coupling Screw should protrude approximately 0.21" (5.3 mm) from the end of tool).

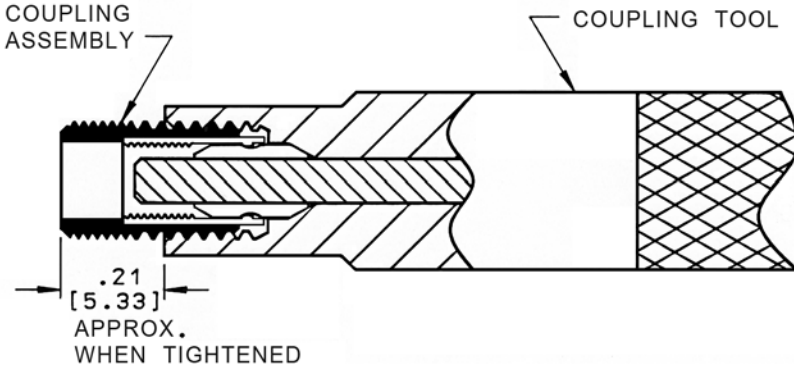

6. Thread the tool/coupling assembly counterclockwise onto the chamfered tubing with the Tubing Grip, applying slight force until resistance is felt after approximately 5 turns.

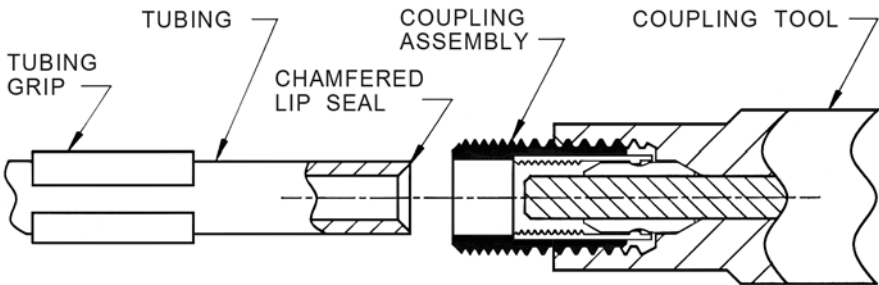

7. Unscrew the coupling from tool.

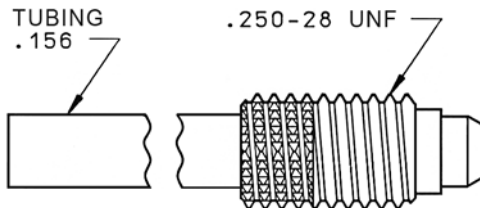

Unless otherwise specified, dimensions are in inches [mm].

156 MINSTAC Coupling Installation

Coupling Installation Tools

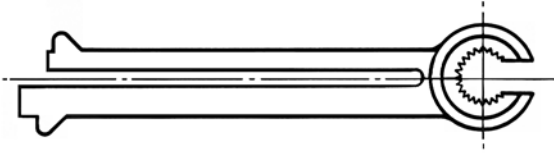

Torque Wrench
TTTA9500343A

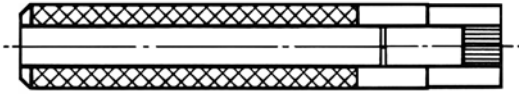

Wrench
TTTA9500427C

Procedure:

1. Start threading the coupling assembly into a 156 MINSTAC boss using Spline Wrench (Part Number TTTA9500427C).

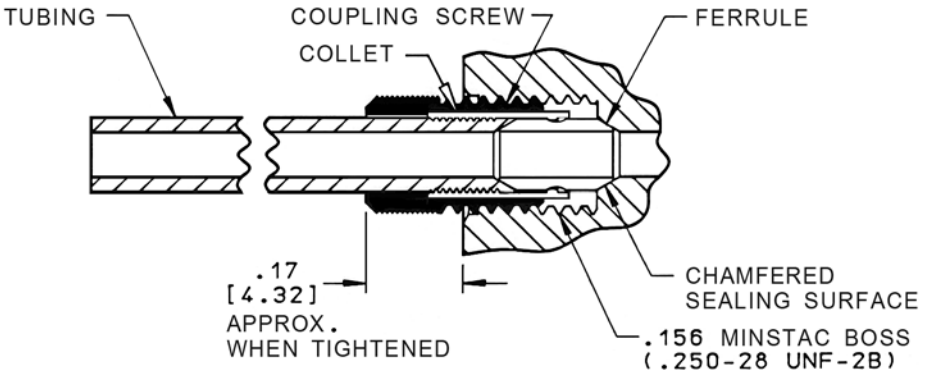

Procedure continued:

2. Tighten the fitting between 7 to 21 ozf•in (0.05 to 0.15 N-m) by slipping the Lee Torque Wrench (Part Number TTTA9500343A) onto the knurled Coupling Screw. The minimum torque is achieved by pressing the shorter torque arm clockwise until it just contacts the longer arm. To check that maximum recommended torque is not exceeded, invert the Torque Wrench and press the longer torque arm clockwise until the Coupling Screw begins to move. This should occur before the torque arms make contact. After gaining a feel for the proper torque, use of the Torque Wrench may be discontinued.

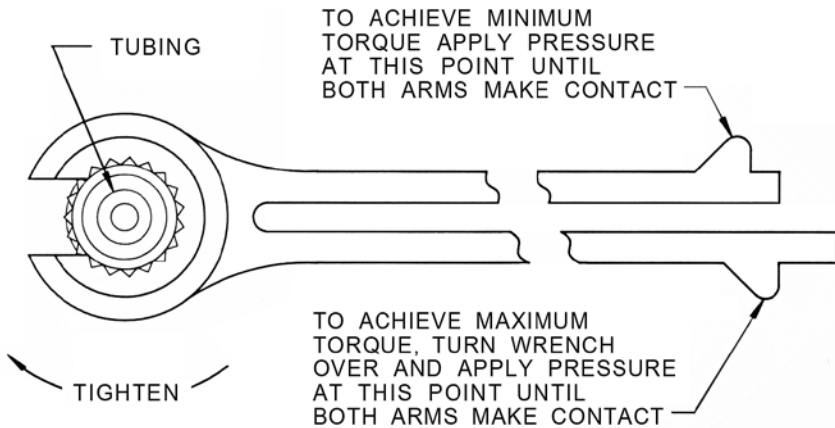

NOTE: Minimum recommended torque: 7 ozf•in (0.05 N-m)
 Maximum recommended torque: 21 ozf•in (0.15 N-m)
 Torque values based on fittings threaded into PEEK bosses.

NOTES



1/4-28 Boss Configuration

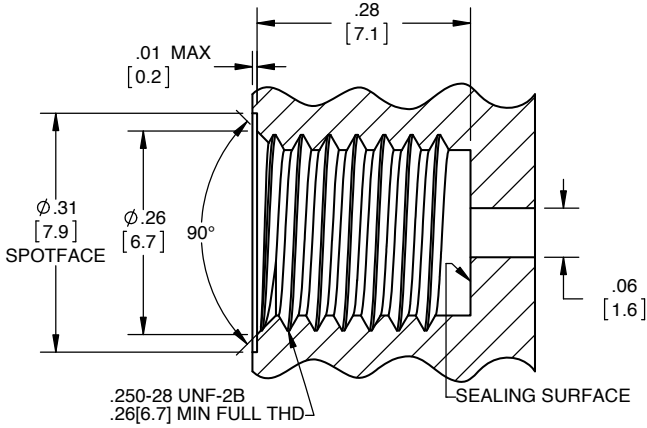

Unless otherwise specified, dimensions are in inches [mm].

1/4-28 Fitting Assembly

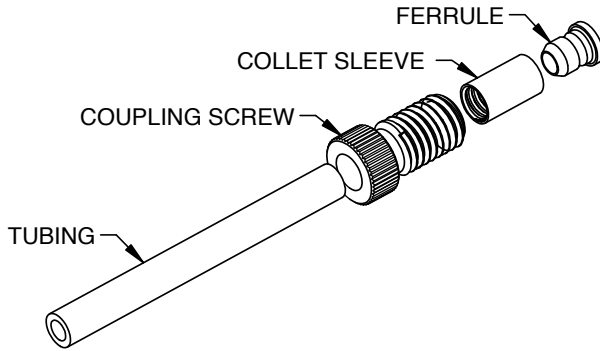

Anodized Aluminum	Coupling Screw: TMAA950307 <input type="checkbox"/> Z *color code _____
PEEK	Collet Sleeve: TMCA9501950Z
PCTFE	Ferrule: TMBA9503910Z

* Color Code: 0 - Black; 1 - Brown; 2 - Red; 3 - Orange; 4 - Yellow; 5 - Green; 6 - Blue; 7 - Violet; 8 - Gray; 9 - Clear

TEFLON® TUBING PART NUMBERING INFORMATION

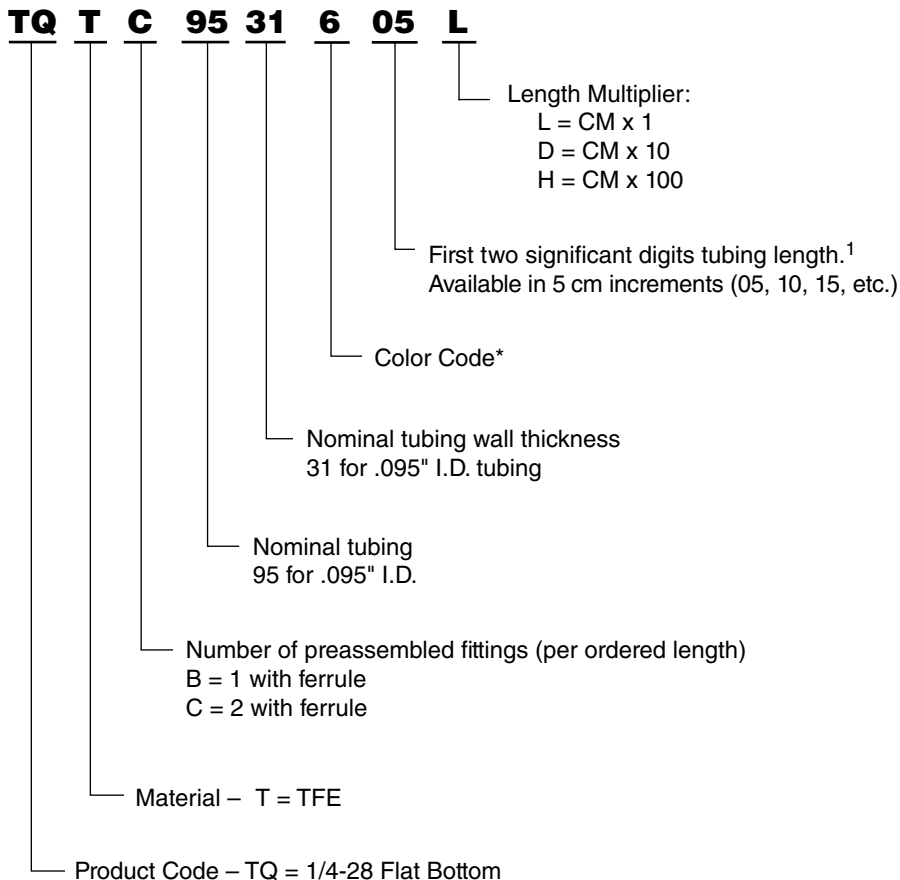

TQT Part Numbers sold as complete tubing assemblies only.

(1.) See [page L54](#) for available stock lengths.

* Color Code: 0-Black; 1-Brown; 2-Red; 3-Orange; 4-Yellow; 5-Green; 6-Blue; 7-Violet; 8-Gray; 9-Clear

062 MINSTAC

TMLA3201950Z – PEEK

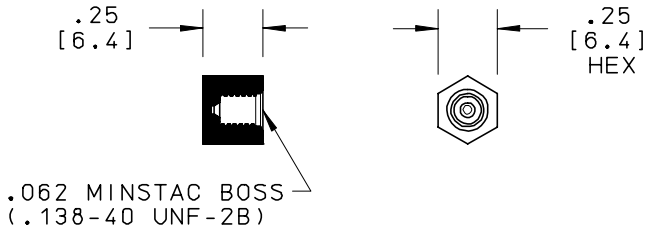

156 MINSTAC

TMLA9501950Z – PEEK

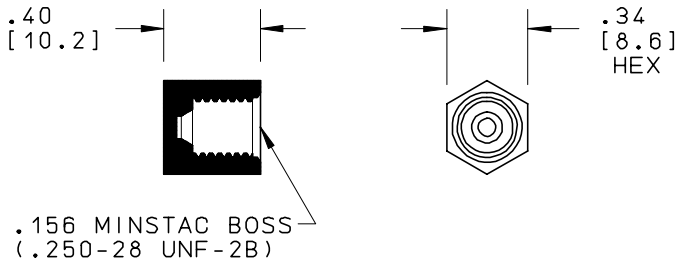

1/4-28 Flat Bottom

TMLA9502950Z – PEEK

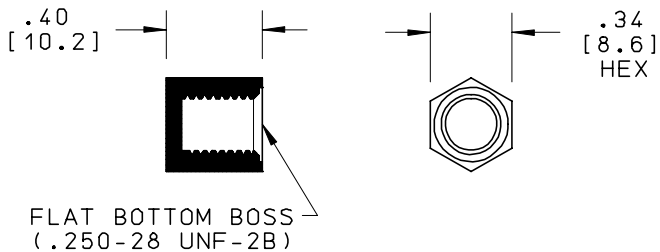

Unless otherwise specified, dimensions are in inches [mm].

062 MINSTAC

TMPA3201919Z – PCTFE

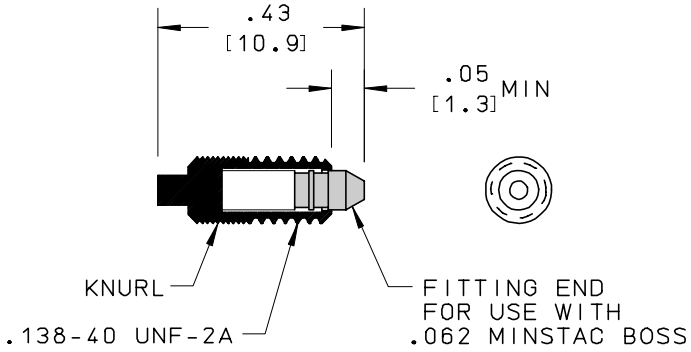

125/156 MINSTAC

TMPA9501959Z – PEEK

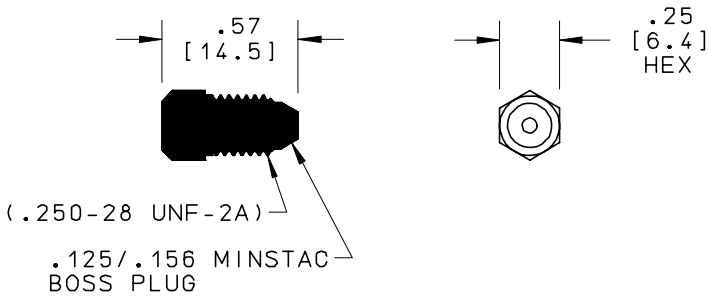

1/4-28 Flat Bottom

TMPA9502909ZA – PEEK -PTFE

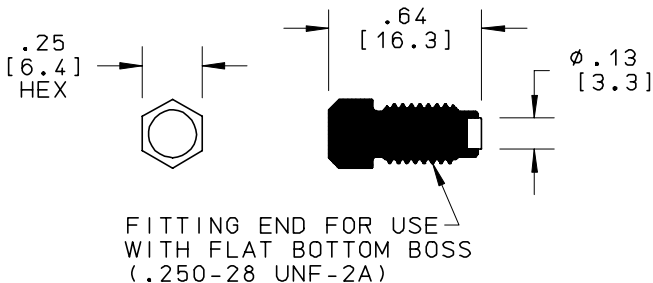

Unless otherwise specified, dimensions are in inches [mm].



062 MINSTAC

TMMA3203950Z – PEEK

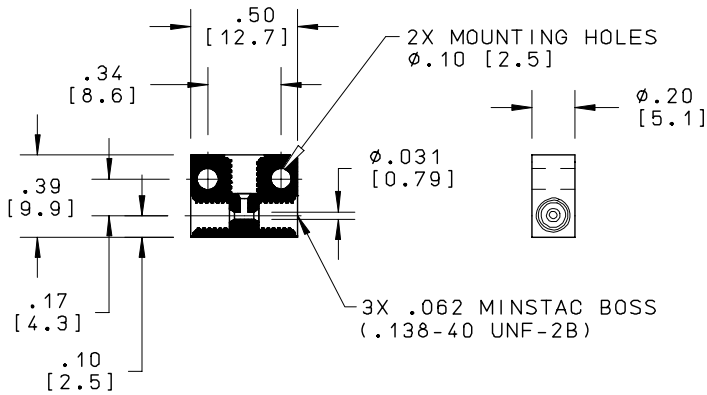

125/156 MINSTAC

TMMA9503950Z – PEEK

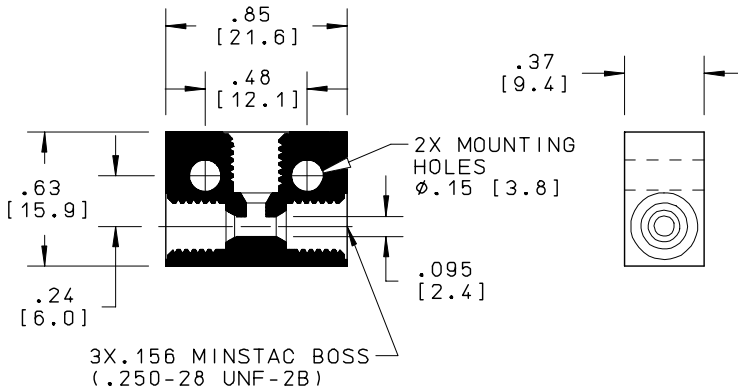

1/4-28 Flat Bottom

TMMA9504950Z – PEEK

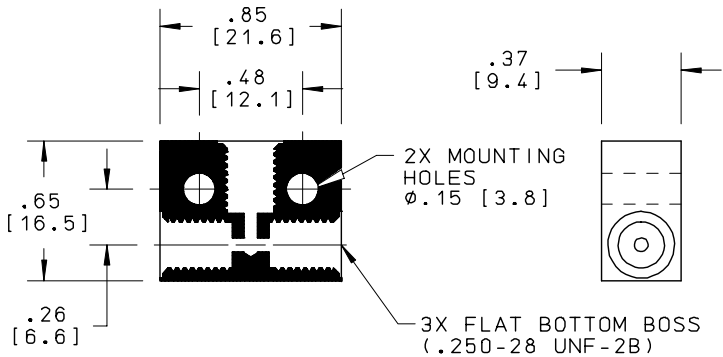

Unless otherwise specified, dimensions are in inches [mm].

062 MINSTAC

TMMA3201950Z – PEEK

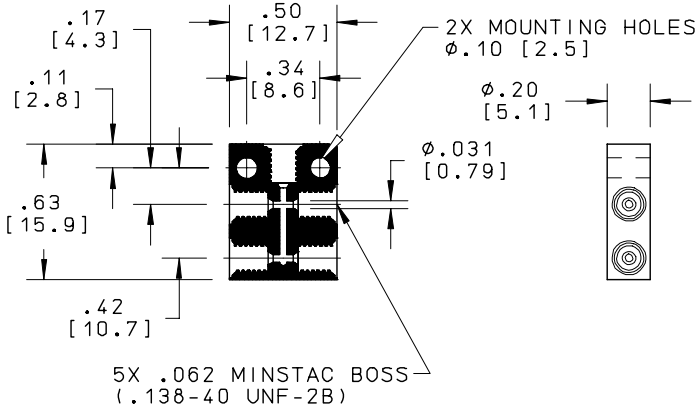

125/156 MINSTAC

TMMA9501950Z – PEEK

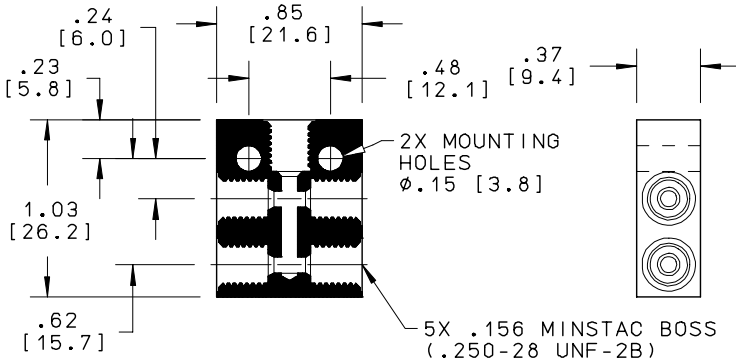

1/4-28 Flat Bottom

TMMA9502950Z – PEEK

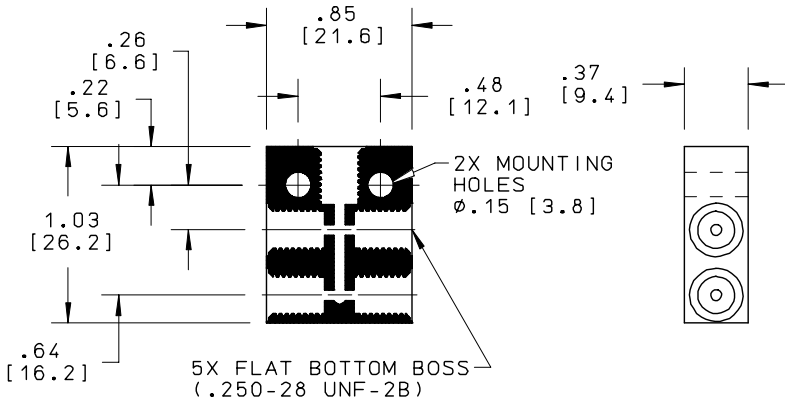

Unless otherwise specified, dimensions are in inches [mm].



125/156 MINSTAC 1/8" Pipe Bushing

TMGA9502950Z – PEEK

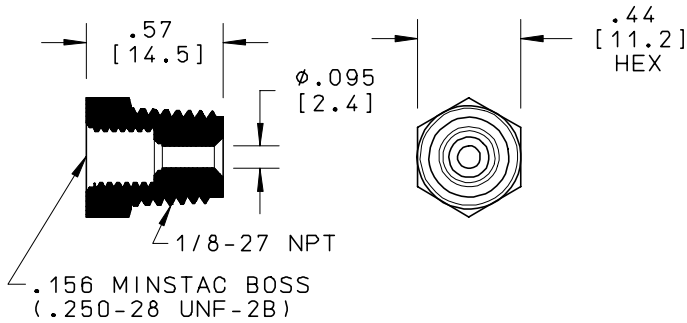

1/4-28 Flat Bottom 1/8" Pipe Bushing

TMGA9504950Z – PEEK

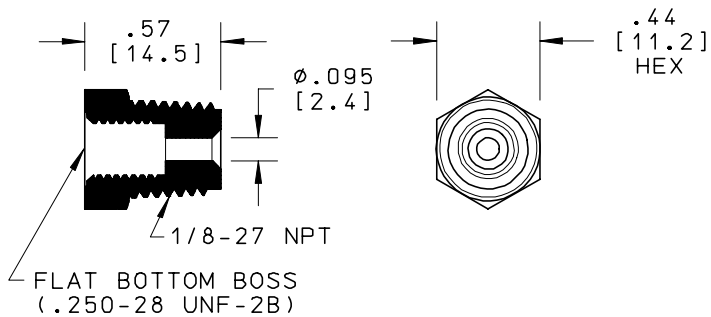

Unless otherwise specified, dimensions are in inches [mm].

125/156 MINSTAC 1/16" Pipe Bushing

TMGA9501950Z – PEEK

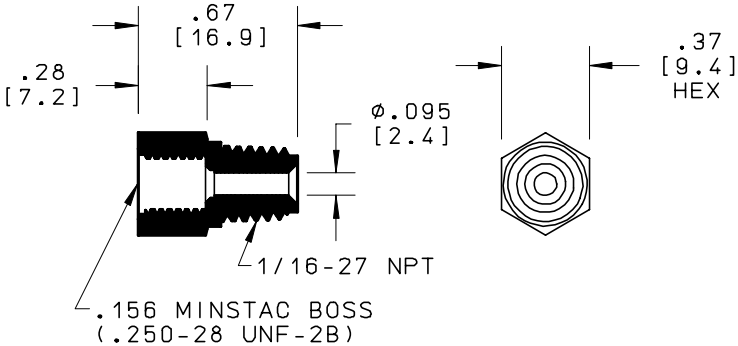

1/4-28 Flat Bottom 1/16" Pipe Bushing

TMGA9503950Z – PEEK

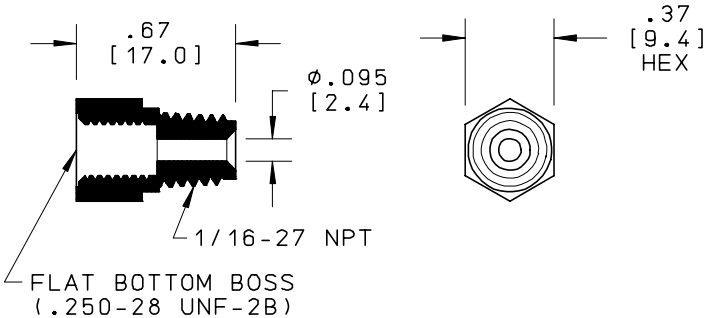

Unless otherwise specified, dimensions are in inches [mm].



062 MINSTAC – LFA Tubing Adapter

Size: 0.05" (1.3 mm) A dia. (0.042" tube I.D.)

TMDA3207920Z Valox®

TMDA3207950Z PEEK

Size: 0.07" (1.8 mm) A dia. (0.060" tube I.D.)

TMDA3201930Z POM

TMDA3201950Z PEEK

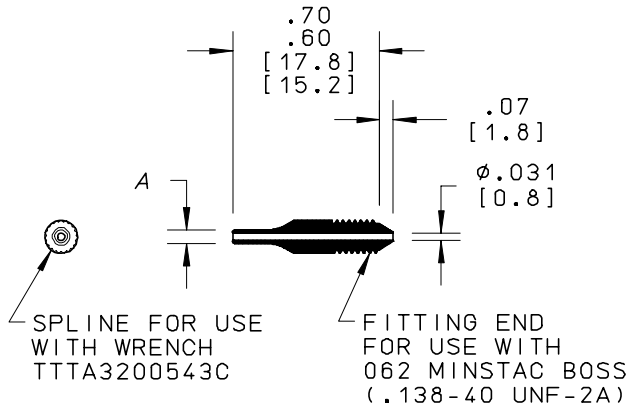

125/156 MINSTAC Boss – LFA Tubing Adapter

TMDA9501950Z (.060" tube I.D.) – PEEK – A = 0.07" (1.8 mm) Dia.

TMDA9507950Z (.042" tube I.D.) – PEEK – A = 0.05" (1.3 mm) Dia.

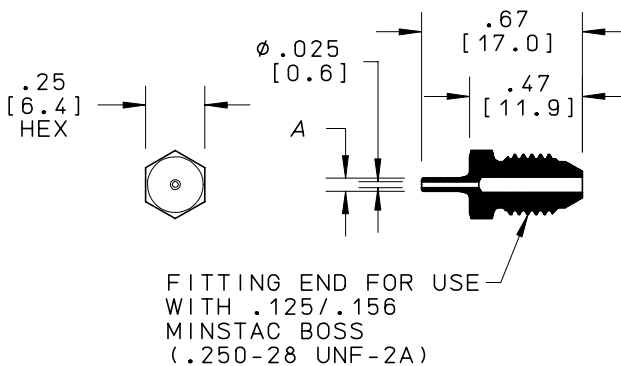

Unless otherwise specified, dimensions are in inches [mm].

125/156 MINSTAC Soft Tubing Adapter

TMDA9501920Z – Valox®

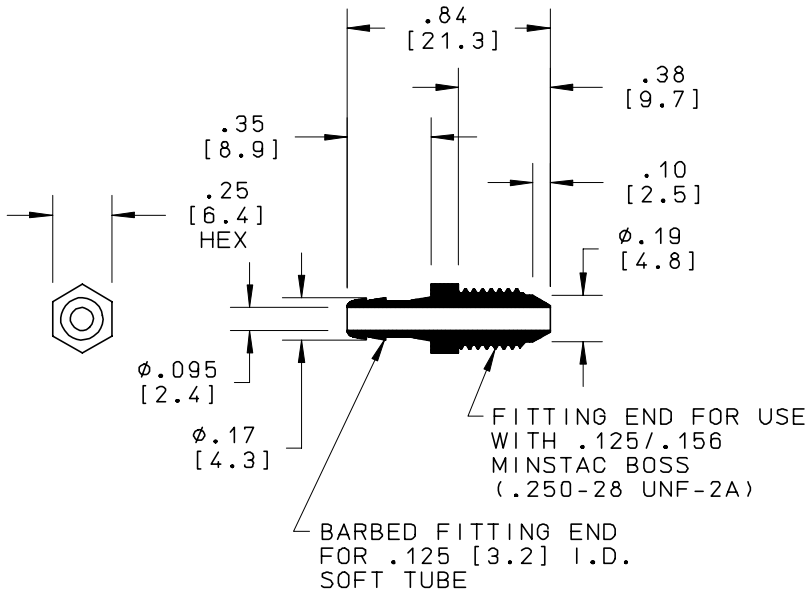

125/156 MINSTAC 1/4-28 Flat Bottom Ferrule

TMBA6202910Z – PCTFE

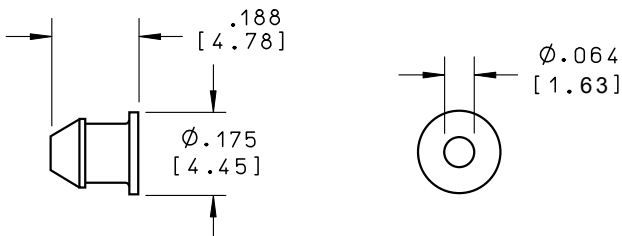
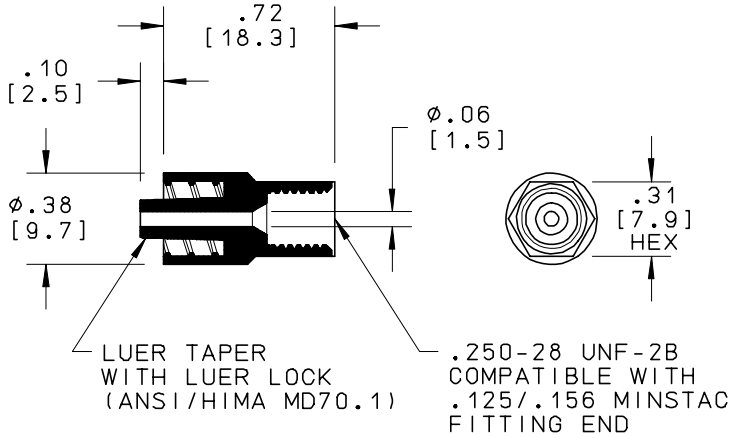

Image not drawn to scale.

Unless otherwise specified, dimensions are in inches [mm].

125/156 MINSTAC – Male Tube – Luer Adapter

TMRA9503950Z – PEEK



125/156 MINSTAC – Female Tube – Luer Adapter

TMRA9502950Z – PEEK

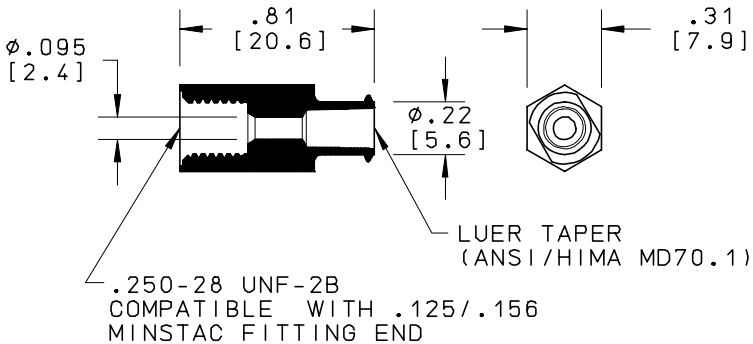

Unless otherwise specified, dimensions are in inches [mm].

125/156 MINSTAC – Female Boss – Female Tube Luer Adapter

TMRA9501950Z – PEEK

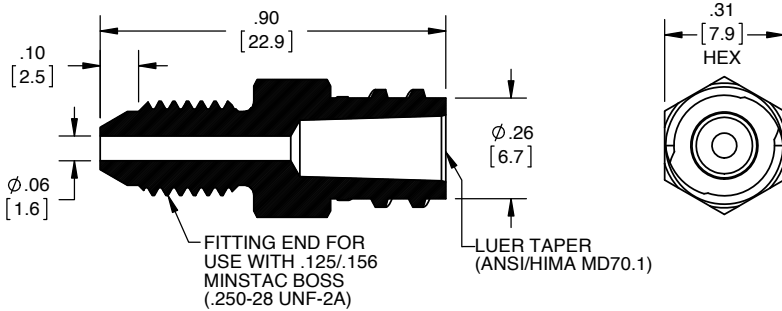

062 MINSTAC – 1/4-28 Flat Bottom Adapter

TMDA3204950Z – PEEK – PTFE

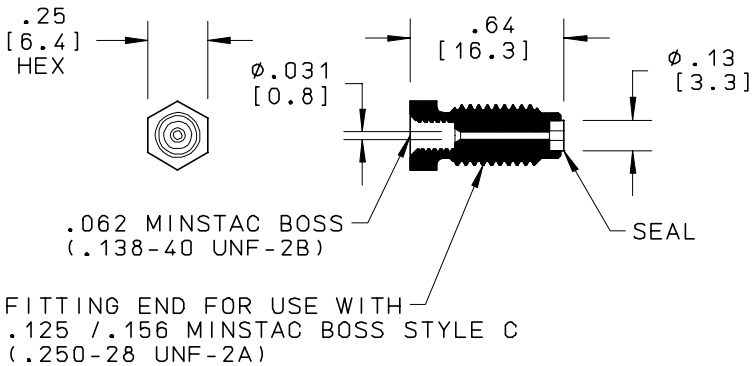

Unless otherwise specified, dimensions are in inches [mm].

1/4-28 Flat Bottom – 062 MINSTAC

TMDA3212950Z – PEEK

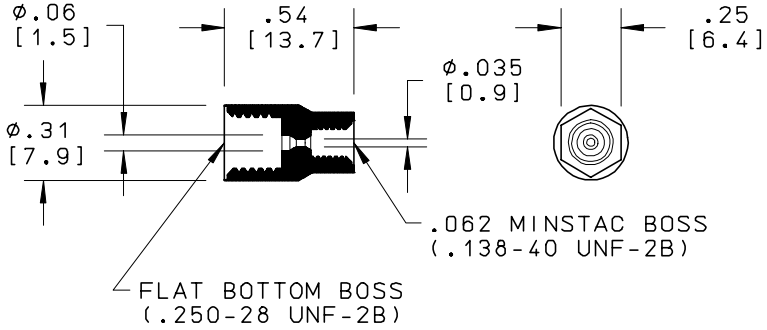

062 MINSTAC Adapter – 125/156 MINSTAC

TMDA3203950Z – PEEK

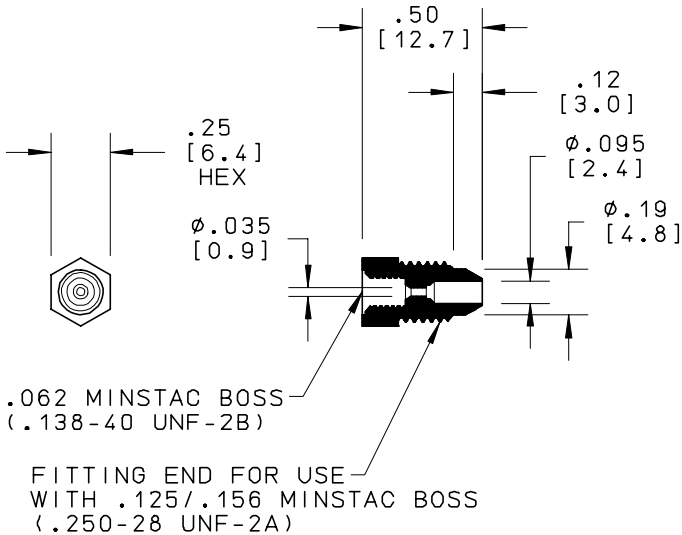

Unless otherwise specified, dimensions are in inches [mm].

125/156 MINSTAC – 062 MINSTAC Adapter

TMDA9502950Z – PEEK

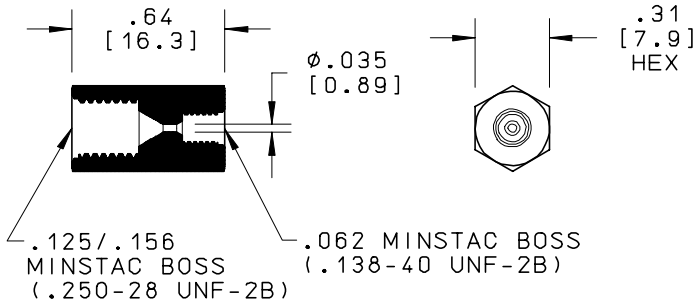

062 MINSTAC Male – 062 MINSTAC Male

TMUD3205950 – PEEK

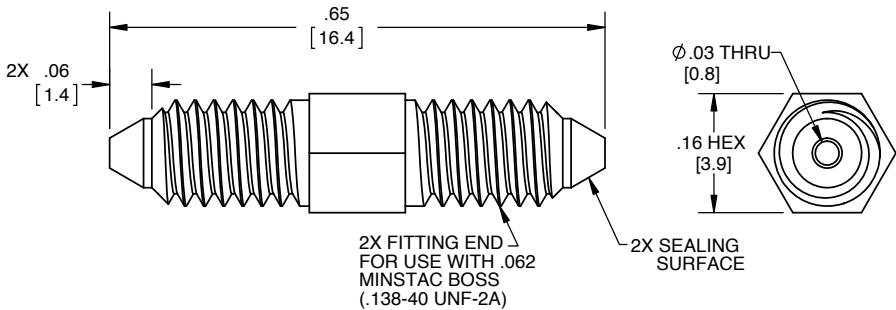

Image not drawn to scale.

Unless otherwise specified, dimensions are in inches [mm].



062 MINSTAC Tubing Union

TMUA3201950Z – PEEK

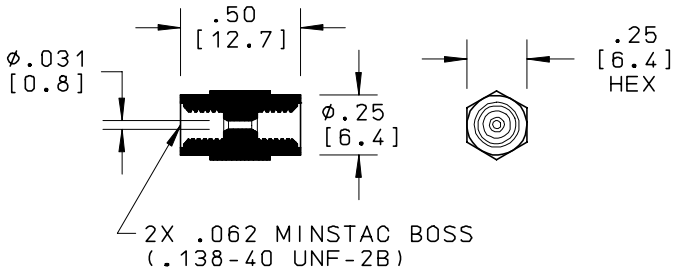

1/4-28 Flat Bottom Tubing Union

TMUA9503950Z – PEEK

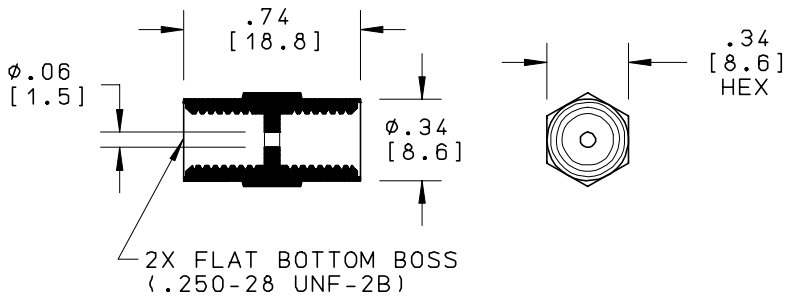

125/156 MINSTAC Tubing Union

TMUA9501950Z – PEEK

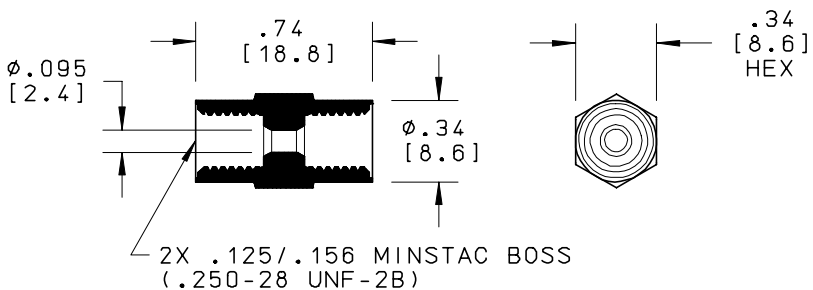

Unless otherwise specified, dimensions are in inches [mm].

062 MINSTAC Bulkhead Union

TMUA3202950A – PEEK – Nut: Nylon

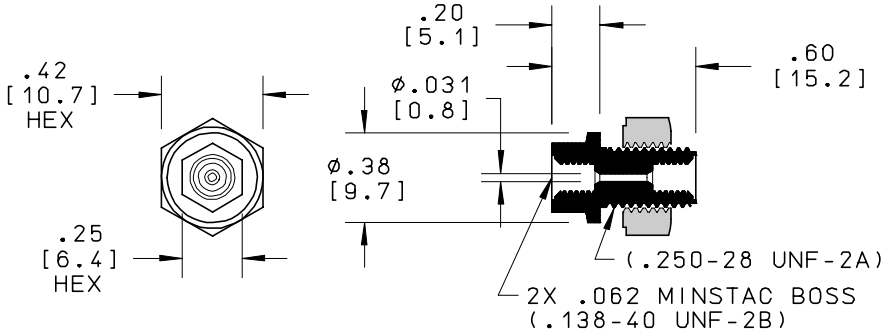

1/4-28 Flat Bottom Bulkhead Union

TMUA9504950Z – PEEK – Nut: Nylon

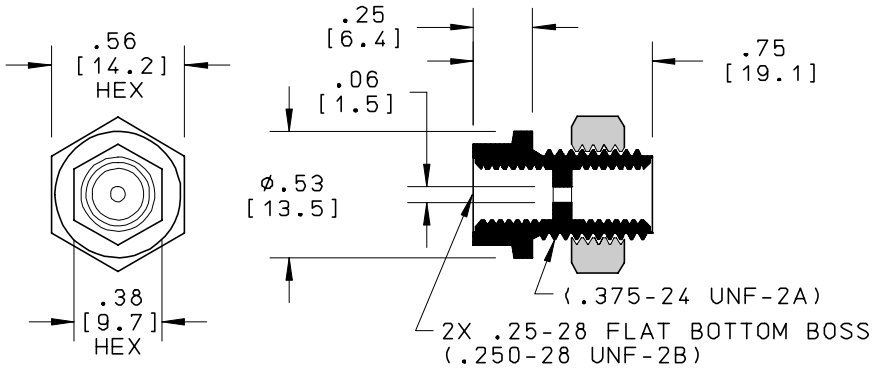

125/156 MINSTAC Bulkhead Union

TMUA9502950Z – PEEK – Nut: Nylon

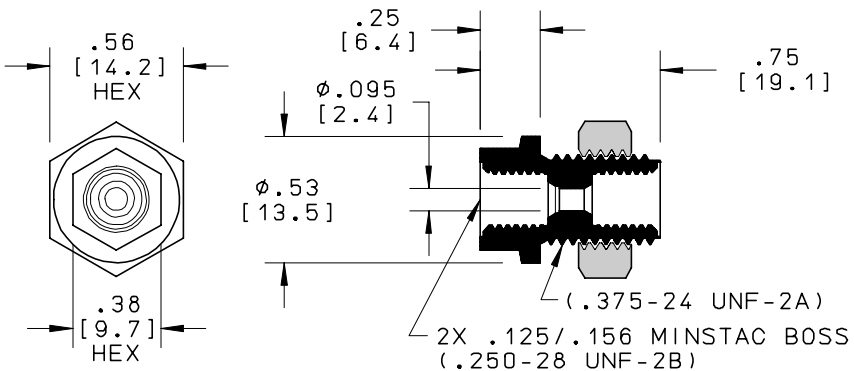

Unless otherwise specified, dimensions are in inches [mm].

Lee MINSTAC Components

The MINSTAC components were developed to expand the total scope and range of the MINSTAC system. A complete line of components is available including check valves, filters and safety screens.

L

Check Valves

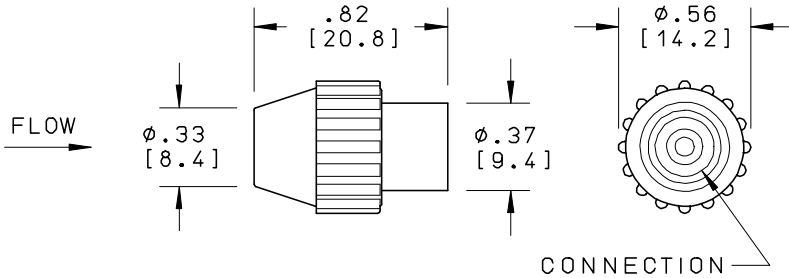

Unless otherwise specified, dimensions are in inches [mm].

PART NUMBER	CONNECTION	LOHM RATE
TKLA3201112H	062 MINSTAC (.138-40)	1000
TKLA9501130D	156 MINSTAC (1/4-28)	300
TKLA9502130D	1/4-28 Flat Bottom Boss	300

- Chemically Inert
- Materials: PEEK Body, FFKM Diaphragm
- Cracking Pressure: 4 in. H₂O (1.0 kPa)
- Leakage: 10 μ L/min. at 28 in. H₂O in Checked Direction
- Maximum Pressure in Checked Direction
 - 75 psig (517 kPa) (062 MINSTAC)
 - 40 psig (276 kPa) (125/156 MINSTAC, 1/4-28 Flat Bottom Boss)
- Lohm Rate
 - 1,000 Lohms (062 MINSTAC)
 - 300 Lohms (125/156 MINSTAC, 1/4-28 Flat Bottom Boss)
- 35 micron (minimum) filtration recommended

Lee LFA Filter *

LFFA4202035A: 35 micron

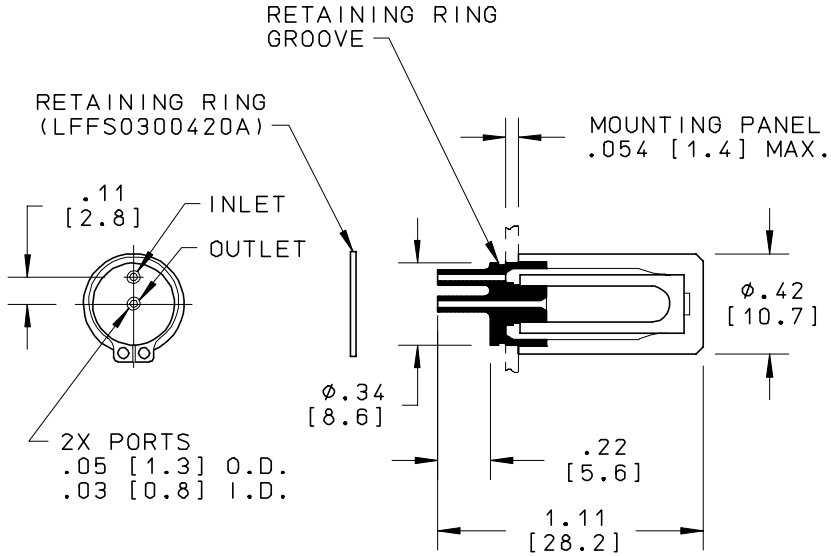

- Micron rating: 35 micron nominal
- Lohm rating: 1,500 Lohms
- Operating pressure: 30 psig (207 kPa) maximum
- Panel mounted ø .350" (8.89 mm) diameter hole, 0.054" (1.37 mm) maximum plate thickness
- Material:
 - Filter: UHMW Polyethylene
 - Housing: Valox® and PC
- Optional retaining ring available, LFFS0300420A
- Use with 0.040" ID Soft Tubing (TUVA4220900A)

* Suitable for LFA Series solenoid valves with .054" ports (See [Section B](#)).

Unless otherwise specified, dimensions are in inches [mm].

In-Line Filter

Tube I.D.

TCFA1201035A: 35 micron
 TCFA6202035A: 35 micron

.125" (3.2 mm)
 .062" (1.6 mm)

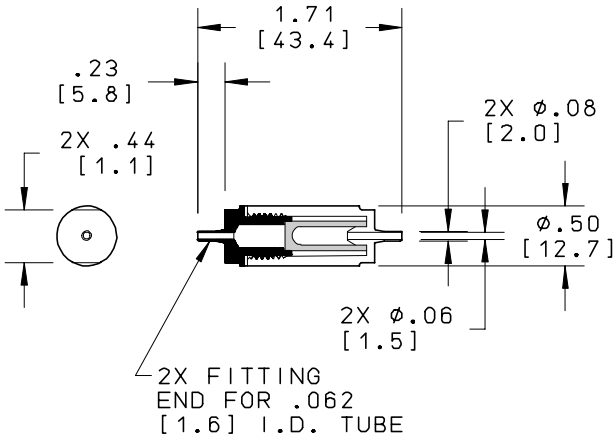
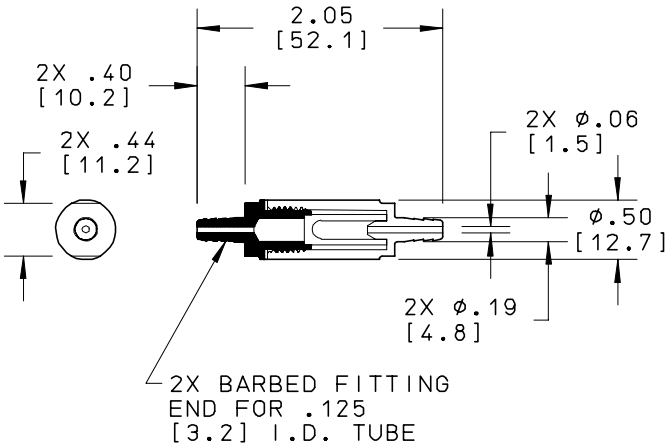

- **Materials**
 Body: PC
 Filter Element: UHMW Polyethylene
- **Replacement Filter Element: 35 micron TCFS0300210A**
- **Max. Operating Pressure: 30 psig (207 kPa)**

Unless otherwise specified, dimensions are in inches [mm].



062 MINSTAC In-Line Filter

TKFA3202135A: 35 micron (1300 Lohm)

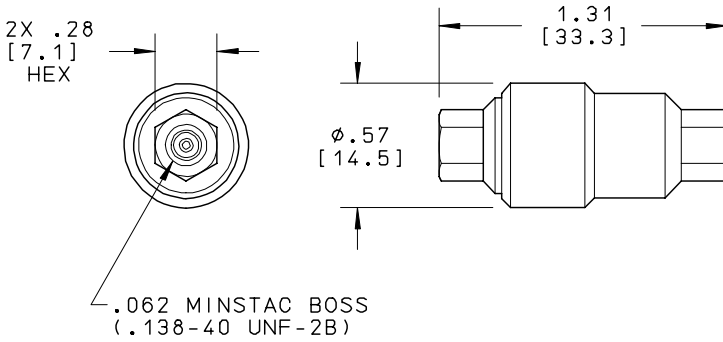

125/156 MINSTAC In-Line Filter

TKFA9502135A: 35 micron (300 Lohm)

TKFA9502110A: 10 micron (300 Lohm)

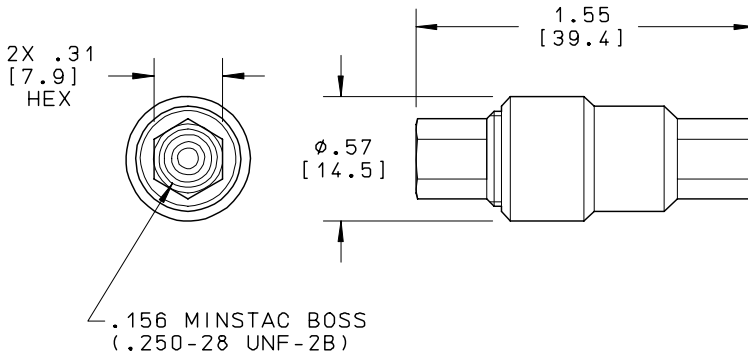

- Materials
 - Body: PEEK
 - Filter Element: UHMW PE
 - Seal: PTFE
- Replacement Filter Element: 35 micron TCFS0300560A
- Operating Pressure: 100 psig (690 kPa)

Unless otherwise specified, dimensions are in inches [mm].

062 MINSTAC Safety Screen

INMX0350000A: 12 micron

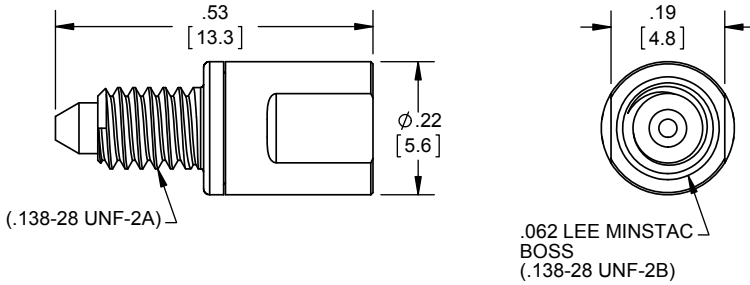

1/4-28 Flat Bottom Safety Screen

INMX0350250A: 35 micron

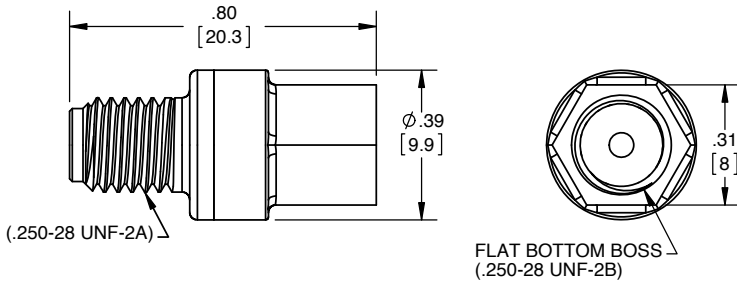

- Materials: PEEK, PTFE (1/4-28 only)
- Maximum Operating Pressure: 120 psig (827 kPa)
- Lohm Rate
 - INMX0350000A: 2100 Lohms
 - INMX0350250A: 250 Lohms
- Internal screen is not replaceable

Unless otherwise specified, dimensions are in inches [mm].

062 MINSTAC – Safety Screen

INMX0502300A: 12 micron

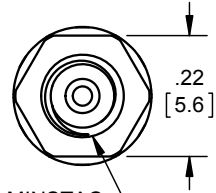
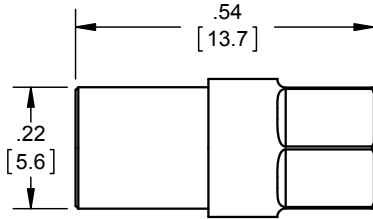

2X.062 LEE MINSTAC
BOSS
(.138-28 UNF-2B)

1/4-28 Flat Bottom – Safety Screen

INMX0503300A: 35 micron

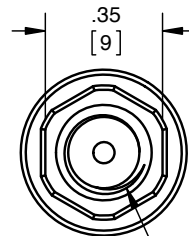
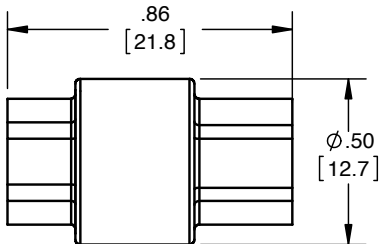

2X FLAT BOTTOM BOSS
(.250-28 UNF-2B)

- Materials: PEEK
- Maximum Operating Pressure
 - INMX0502300A: 150 psig
 - INMX0503300A: 120 psig
- Lohm Rate
 - INMX0502300A: 1450 Lohms
 - INMX0503300A: 280 Lohms

Unless otherwise specified, dimensions are in inches [mm].

MINSTAC Tubing

MINSTAC tubing assemblies are available in standard lengths and configurations (specials are available for OEM applications).

TUTA (cm)	TUTB/TQTB (cm)	TUTC/TQTC (cm)
—	5	5
—	10	10
—	15	15
—	20	20
—	25	25
—	—	30
—	—	40
50	50	50
—	75	75
—	100	100
300	—	—
3000	—	—



MINSTAC Starter Kits

Lee offers four starter kits to familiarize the new user with the versatility of the MINSTAC system and assist in organizing preproduction bread boards.

062 MINSTAC Fitting End Kit

Lee Part Number TMZA3202010Z

Kit Includes:	1	–	TTTA3201443A	Collet Tool
	1	–	TTTA3201543A	Chamfer Tool
	1	–	TTTA3201243A	Torque Wrench
	1	–	TTTA6202027A	Knife
	25	–	TMAA3202079Z	Coupling Screws
	25	–	TMBA3202910Z	Ferrules
	25	–	TMCA3202030Z	Collet Sleeves
	1	–	TUTA3216930D	10 feet of Tubing
	1	–	TTTX0500900A	Rubber Tubing Grip

062 MINSTAC Tool Kit

Lee Part Number TTTA3201043C

Kit Includes:	1	–	TTTA3201543A	Chamfer Tool
	1	–	TTTA3201443A	Collet Installation Tool
	1	–	TTTA3200643A	Combination Spade Drill
	1	–	TTTA3200743A	Plug Tap with Stop
	1	–	TTTA3200843A	Bottoming Tap with Stop
	1	–	TTTA3200543C	Spline Wrench
	1	–	TTTA3201243A	Torque Wrench

125 MINSTAC Fitting End Kit

Lee Part Number TMZA6201010Z

Kit Includes:	1	–	TTTA6200143A	Coupling Assembly Tool
	1	–	TTTA6200343A	Coupling Assembly Tool (ferruleless)
	1	–	TTTA6202027A	Knife
	1	–	TTTA6202227A	Torque Wrench
	25	–	TMAA6201929Z	Coupling Screws
	25	–	TMBA6201910Z	Ferrules
	25	–	TMCA6201920Z	Collets
	1	–	TUTA6230930D	10 feet of Tubing (TFE)
	1	–	TTTX0500900A	Rubber Tubing Grip

125 MINSTAC Tool Kit

Lee Part Number TTTA6201827C

- Kit Includes:
- 1 – TTTA6200143A Coupling Assembly Tool
 - 1 – TTTA6200343A Coupling Assembly Tool (ferruleless)
 - 1 – TTTA6201927A Combination Spade Drill
 - 1 – TTTA6200227C Combination Wrench – .25 in.
 - 1 – TTTA6201627A Plug Tap with Stop
 - 1 – TTTA6201727A Bottoming Tap with Stop
 - 1 – TTTA6202227A Torque Wrench

156 MINSTAC Fitting End Kit

Lee Part Number TMZA9501110Z

- Kit Includes:
- 1 – TTTA9500127A Coupling Assembly Tool
 - 1 – TTTA9500343A Torque Wrench
 - 1 – TTTA6202027A Knife
 - 25 – TMAA9501079Z Coupling Screws
 - 25 – TMBA9501910Z Ferrules
 - 25 – TMCA9501950Z Collet Sleeves
 - 1 – TUTA9531930D 10 feet of Tubing
 - 1 – TTTX0500900A Rubber Tubing Grip

156 MINSTAC Tool Kit

Lee Part Number TTTA9500443C

- Kit Includes:
- 1 – TTTA9500127A Coupling Assembly Tool
 - 1 – TTTA9500227A Combination Boss Drill
 - 1 – TTTA9500343A Torque Wrench
 - 1 – TTTA9500427C Wrench
 - 1 – TTTA6201627A Plug Tap with Stop
 - 1 – TTTA6201727A Bottoming Tap with Stop



Nozzles



M

Lee offers a wide range of nozzles capable of providing either a precise droplet or atomized fluid. Several mounting styles allow these nozzles to be incorporated directly onto our VHS dispensing valves, or to be connected to valves using soft flexible tubing.

Dispense nozzles are available in straight tubes or with jeweled orifices (allowing tighter droplet control).

- Mounting styles include:
 - 062 MINSTAC
 - 062 MINSTAC w/ HEX nut
 - Straight tube for use with soft tubing

Atomizing nozzles are available in airless and air assisted models.

Dispensing Nozzles

Lee dispensing nozzles with 062 threads mount into any Lee 062 MINSTAC boss. This allows the nozzle to be mounted directly onto our VHS micro-dispensing valves. Direct mounting reduces the overall package size and the fluid volume between the nozzle and valve sealing point. This reduced volume decreases the fluid reaction time (time from when the valve opens until the fluid exits the nozzle). This will also allow flow control using PWM (pulse width modulation).

The hypo port design can be pressed into flexible tubing allowing remote mounting of the nozzle. This can be used to decrease the center to center spacing or to place the nozzle away from the valving.

Lee offers Nitinol® dispensing nozzles. These flexible nozzles can be side loaded and still return to their original shape. This prevents permanent damage when they are accidentally struck.

Atomizing Nozzles

Lee atomizing nozzles are offered in both air assisted and airless designs. The airless design provides atomization at relatively low pressure (15 psi) without the need for an external air source. These are offered in a 062 MINSTAC mounting style.

Air assisted nozzles provide atomization with as little as 5 psi fluid and atomizing air pressures. These are designed for use with soft tubing.

Special nozzles can be engineered for insertion into manifolds, and with coatings to reduce droplet adhesion.

Dispensing Nozzles

CONFIGURATION A

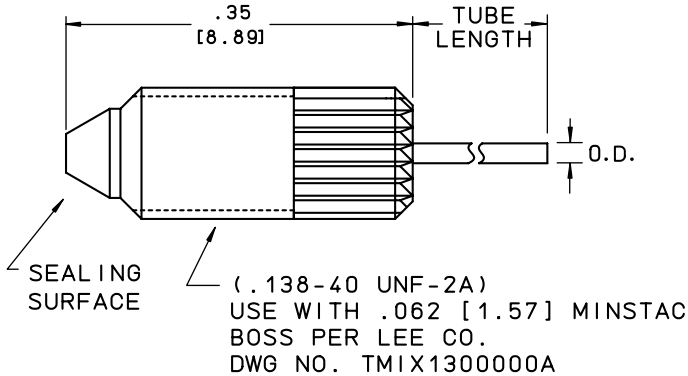

CONFIGURATION B

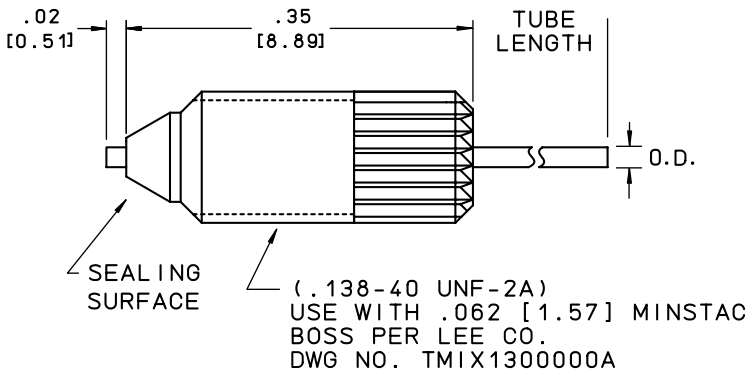

CONFIGURATION C

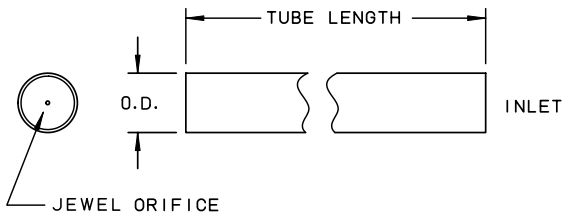

Tube is stainless steel. Mounted orifice is sapphire.

Unless otherwise specified, dimensions are in inches [mm].

062 MINSTAC Straight Tube

PART NUMBER	TUBE I. D.	TUBE O. D.	TUBE LENGTH	LOHMS	CONFIGURATION
INZA3070940K	0.010" (0.25 mm)	0.02" (0.51 mm)	0.35" (8.9 mm)	40,000	A
INZA3102514K	0.010" (0.25 mm)	0.02" (0.51 mm)	1.00" (25.4 mm)	14,000	A
INZA5102514K	0.010" (0.25 mm)	0.02" (0.51 mm)	1.00" (25.4 mm)	14,000	B*
INZA5100914K	0.010" (0.25 mm)	0.02" (0.51 mm)	0.35" (8.9 mm)	14,000	B*
INZA3100914K	0.010" (0.25 mm)	0.02" (0.51 mm)	0.35" (8.9 mm)	14,000	A
INZA3330997D	0.030" (0.76 mm)	0.05" (1.27 mm)	0.37" (9.4 mm)	975	A
INZA3362597D	0.030" (0.76 mm)	0.07" (1.65 mm)	1.00" (25.4 mm)	975	A

Wetted Material: Stainless Steel

* PTFE coated.

062 MINSTAC with Jeweled Orifice

PART NUMBER	ORIFICE I. D.	TUBE O. D.	TUBE LENGTH	LOHMS	CONFIGURATION
INZA4620928T	0.002" (0.05 mm)	0.050" (1.3 mm)	0.35" (8.9 mm)	280,000	A
INZA4630912T	0.003" (0.08 mm)	0.050" (1.3 mm)	0.35" (8.9 mm)	125,000	A
INZA4542560K	0.004" (0.10 mm)	0.020" (0.5 mm)	1.00" (25.4 mm)	60,000	A
INZA4640960K	0.004" (0.10 mm)	0.050" (1.3 mm)	0.35" (8.9 mm)	60,000	A
INZA6542460K	0.004" (0.10 mm)	0.020" (0.5 mm)	0.96" (24.4 mm)	60,000	B*
INZA4650935K	0.005" (0.13 mm)	0.050" (1.3 mm)	0.35" (8.9 mm)	35,000	A
INZA4652535K	0.005" (0.13 mm)	0.050" (1.3 mm)	0.97" (24.6 mm)	35,000	A
INZA4655035K	0.005" (0.13 mm)	0.050" (1.3 mm)	1.97" (50.0 mm)	35,000	A
INZA4670915K	0.0075" (0.19 mm)	0.050" (1.3 mm)	0.35" (8.9 mm)	15,400	A
INZA6670915K	0.0075" (0.19 mm)	0.050" (1.3 mm)	0.35" (8.9 mm)	15,400	A
INZA4710975H	0.010" (0.25 mm)	0.050" (1.3 mm)	0.35" (8.9 mm)	7,500	A

Wetted Materials: Stainless Steel, Sapphire

* PTFE coated.

Straight Tube with Jeweled Orifice

PART NUMBER	ORIFICE I. D.	TUBE O. D.	TUBE LENGTH	LOHMS	CONFIGURATION
INZA2631412T	0.003" (0.08 mm)	0.050" (1.3 mm)	0.57" (14.5 mm)	125,000	C
INZA2543460K	0.004" (0.10 mm)	0.020" (0.51 mm)	1.33" (33.8 mm)	60,000	C
INZA2540660K	0.004" (0.10 mm)	0.020" (0.51 mm)	0.25" (6.4 mm)	60,000	C
INZA2651435K	0.005" (0.13 mm)	0.050" (1.3 mm)	0.57" (14.5 mm)	35,000	C
INZA2653035K	0.005" (0.13 mm)	0.050" (1.3 mm)	1.17" (29.7 mm)	35,000	C
INZA2671415K	0.0075" (0.19 mm)	0.050" (1.3 mm)	0.57" (14.5 mm)	15,400	C
INZA2961331H	0.016" (0.41 mm)	0.043" (1.09 mm)	0.50" (12.7 mm)	3,100	C
INZA2621428T	0.002" (0.05 mm)	0.050" (1.3 mm)	0.57" (14.5 mm)	280,000	C

Wetted Materials: Stainless Steel, Sapphire

Hex Dispensing Nozzles

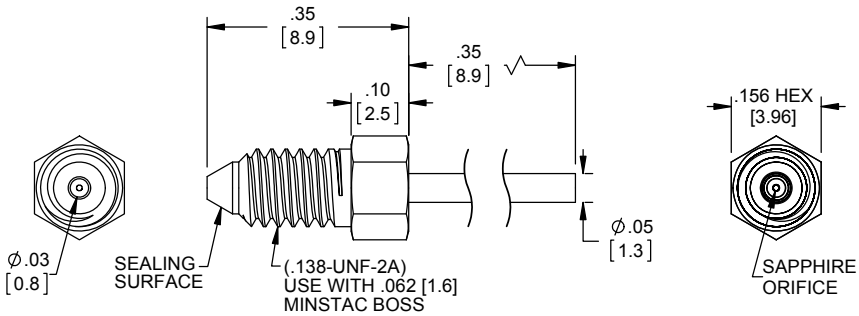

- Nozzles are 062 MINSTAC thread and sealing surface
- MINSTAC spline has been replaced with 0.156 HEX
- Compatible with all LEE 062 MINSTAC components and valves
- Wetted Materials: Stainless Steel, Sapphire, Epoxy

HEX MINSTAC with Jeweled Orifice

PART NUMBER	JEWEL I.D.	LOHMS
INZA7710975H	0.010" (0.25 mm)	7,500
INZA7670915K	0.008" (0.20 mm)	15,400
INZA7650935K	0.005" (0.13 mm)	35,000
INZA7640960K	0.004" (0.10 mm)	60,000
INZA7630912T	0.003" (0.08 mm)	125,000
INZA7620928T	0.002" (0.05 mm)	280,000

Unless otherwise specified, dimensions are in inches [mm].

Nitinol® Dispensing Nozzles

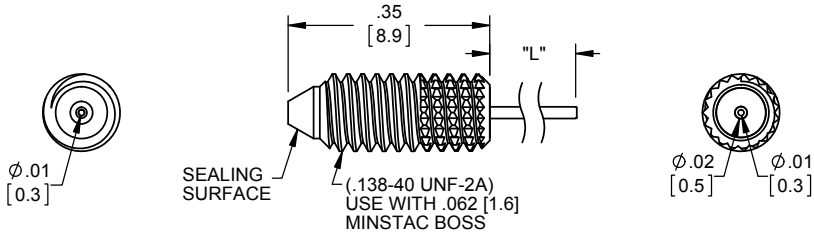

Nitinol nozzles allow precise dispensing and flexibility. The Nitinol material is resistant to permanent deformation. This allows the nozzle to be bent and still return to its original shape. The nozzle can also be passed into twisted or restrictive passageways.

- Wetted material: Nitinol, Stainless Steel, Epoxy
- Compatible with 062 MINSTAC bosses

062 MINSTAC with Straight Nitinol® Tube

PART NUMBER	LENGTH "L"	LOHMS
INZA9102520K	1.0" (25.4 mm)	20,000
INZA9105132K	2.0" (50.8 mm)	32,000
INZA9107642K	3.0" (76.2 mm)	42,000

Unless otherwise specified, dimensions are in inches [mm].

Atomizing Nozzles

CONFIGURATION A

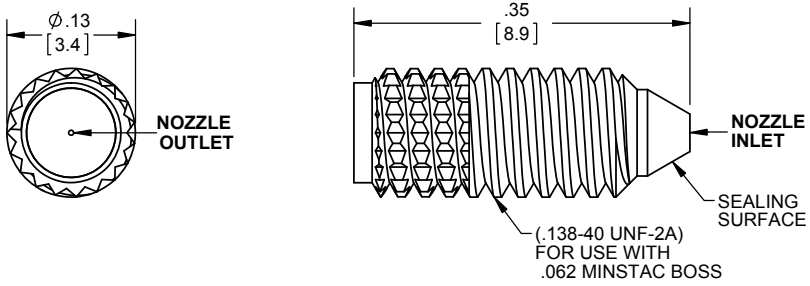

CONFIGURATION B

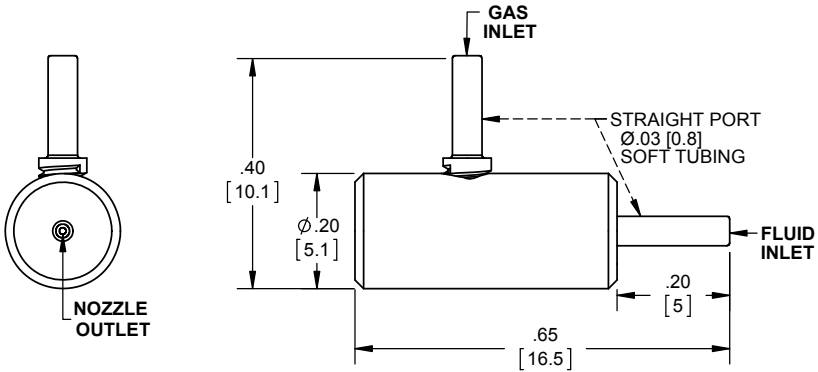

CONFIGURATION C

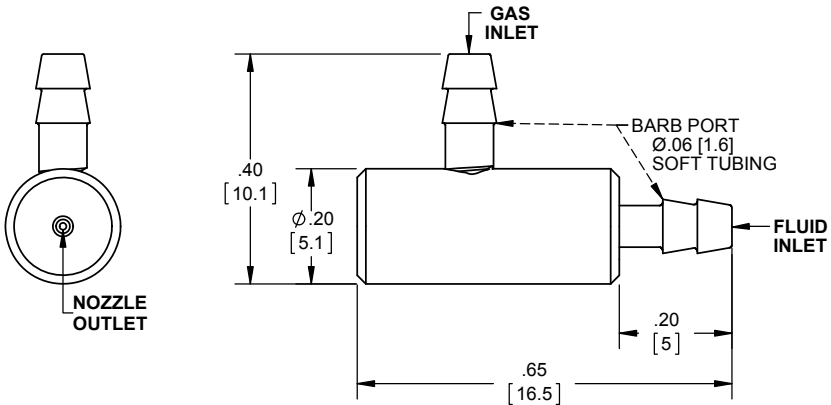

Unless otherwise specified, dimensions are in inches [mm].

Airless Atomizing Nozzles

PART NUMBER	LOHMS	OPERATING PRESSURE (psig)	CONFIGURATION
IAZA1200167K	67,000	10-1000	A
IAZA1200163K	63,000	10-1000	
IAZA1200147K	47,000	20-1000	
IAZA1200134K	34,000	20-1000	
IAZA1200122K	22,000	20-1000	
IAZA1200110K	10,000	20-1000	

Spray Cone: 50° hollow

Wetted Material: Stainless Steel

M

Air Assisted Nozzle

PART NUMBER	LOHMS	OPERATING PRESSURE (psig)	CONFIGURATION
IAZA5200315K	15,000	5-60	B
IAZA5200415K	15,000	5-60	C

Spray Cone: 50° solid

External air pressure of 5 psig min. is required for atomization.

Wetted Materials: Stainless Steel, Epoxy

Nozzle Dispense (steady state)

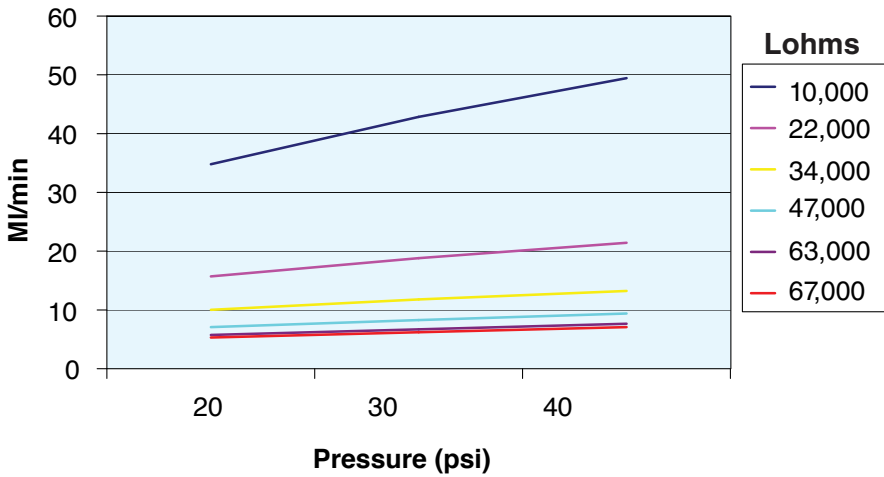

This chart illustrates steady state flow through the nozzles.

Flow rates can be further modified by using pulse width modulation through a VHS valve.

- PTFE coating is surface treatment for wetting only
- Airless nozzles designed for use with 062 MINSTAC system

Special Nozzles

Special nozzle designs are available for OEM applications.

- Sharp Tip
- Long Length
- Wash Nozzles
- Multi-Lumen
- Bent Nozzle
- Nozzle Integrated into Valve
- Barb Connection



IEP Series

N



The Lee IEP Series valves are 2-way, extended performance, axial-flow solenoid operated valves. These are designed for high pressure and high temperature applications where small size and lightweight are critical factors.

The IEP Series valves are supplied with 1/16" inlet and outlet stainless steel tubing. This allows the valve to be connected using standard high pressure chromatography fittings or welded directly in place.

- Two temperatures ranges
 - Standard: 120°F (49°C)
 - High: 275°F (135°C)
- Two pressure ranges
 - Standard: 300 psi (21 bar)
 - High: 800 psi (55 bar)
- All Stainless Steel housing
- Range of seal options
 - FFKM
 - FKM
 - EPDM
- 12 and 24 volt coils available
- Light weight (less than 6 grams)
- Fast (operating speed up to 500 Hz)

Standard materials and configurations are shown on the following pages. The Lee Company can also customize valves to meet specific application requirements. These include custom port configurations.

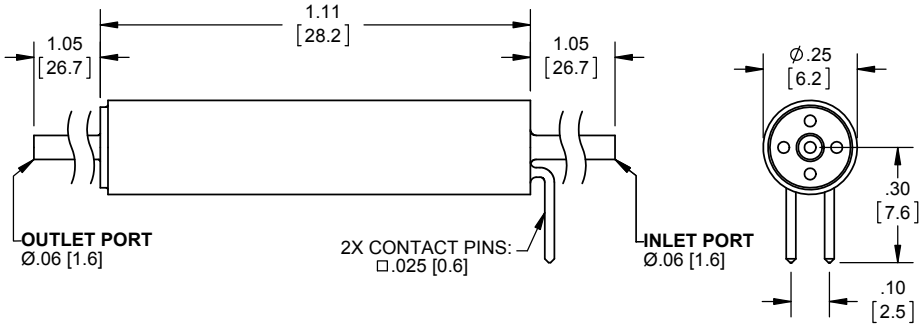

Unless otherwise specified, dimensions are in inches [mm].

PART NUMBER	SEAL MATERIAL ¹	SPIKE VOLTAGE (vdc)	HOLD VOLTAGE (vdc)	POWER @ HOLDING VOLTAGE ² (W)	
IEPA1211141H	FKM	12	1.6	0.25	
IEPA2411141H	FKM	24	3	0.25	
IEPA1221141H	FKM	12	1.6	0.25	
IEPA2421141H	FKM	24	3	0.25	
IEPA1211541H	FFKM	12	1.6	0.25	
IEPA2411541H	FFKM	24	3	0.25	
IEPA1221541H	FFKM	12	1.6	0.25	
IEPA2421541H	FFKM	24	3	0.25	
IEPA1211241H	EPDM	12	1.6	0.25	
IEPA2411241H	EPDM	24	3	0.25	
IEPA1221241H	EPDM	12	1.6	0.25	
IEPA2421241H	EPDM	24	3	0.25	

NOTES: (1) Wetted materials (in addition to seal): 316 stainless steel, Chrome Core[®] 18.

(2) Extreme environmental conditions may require higher power.

(3) Spike time is based on max. operating pressure at 70°F (21°C). Lower pressures will allow shorter spike durations. Higher temperatures will require longer spike durations.

(4) Other Lohm rates are available. Contact The Lee Company.

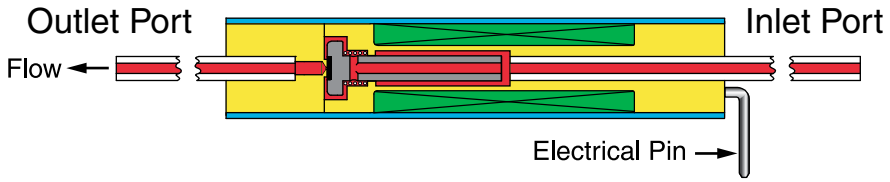

- Coil
- Seal
- Flow Path
- Shield
- Housing
- Plunger

	MAX. SPIKE DURATION ³ (ms)	MAX. OPERATING PRESSURE		MAX. AMBIENT TEMPERATURE		FLOW ⁴
		psig	(bar)	°F	(°C)	Lohms (Cv)
	3.8	800	(55)	120	(49)	4100 (.005)
	3.8	800	(55)	120	(49)	4100 (.005)
	2	800	(55)	275	(135)	4100 (.005)
	2	800	(55)	275	(135)	4100 (.005)
	2	300	(21)	120	(49)	4100 (.005)
	2	300	(21)	120	(49)	4100 (.005)
	3.8	300	(21)	275	(135)	4100 (.005)
	3.8	300	(21)	275	(135)	4100 (.005)
	3.8	800	(55)	120	(49)	4100 (.005)
	3.8	800	(55)	120	(49)	4100 (.005)
	2	800	(55)	275	(135)	4100 (.005)
	2	800	(55)	275	(135)	4100 (.005)

Chrome Core 18 is a registered trade name of Carpenter Technology Corp.

GENERAL SPECIFICATIONS

The following specifications apply to all IEP Series solenoid valves, unless otherwise noted.

Dry Weight: 4.7 g

Internal Volume: 62 μ L

Electrical Characteristics

The IEP valves will actuate at the rated voltage at low pressures (below 60 psi). Higher pressure applications may need a spike and hold driver.

Spike and hold drive circuit modules are available for use with IEP valves (Part Numbers: IECX0501350A, IECX0501500A).

	12 VOLT COIL	24 VOLT COIL
Resistance (ohms)	10.6	37
Inductance: energized (mH)	22.2	5
Inductance: de-energized (mH)	16.5	4.2

N

Operating Pressure

- Valves are designed to operate within the normal ranges listed on [page N4](#).
 Proof Pressure: 2x normal operating pressure
 Burst Pressure: 3x normal operating pressure

Operating Temperature

- Ambient operating temperature range is listed in the Valve Selection Chart [pages N3-4](#).
- Maximum coil temperature not to exceed:
 250°F (121°C) for standard model
 400°F (204°C) for high temperature model
- Higher temperatures limit coil performance. Coil temperature must take into account ambient conditions and self heating of the valve.

Response Time

- Typical response time at 10 psig (air): 0.5 ms

Filtration

System filtration of 10 microns is recommended. Improper filtration can result in damage to the valve (leakage) due to contamination of the sealing surface.

ACCESSORIES

Electrical Connectors

The IEP Series valves use 0.025" electrical pins, on 0.100" centers. Standard electrical connectors that fit these dimensions can be used. Lee also offers pre-made lead assemblies (Part Number IHWX0248010).

Special Applications

Special configurations are available for OEM applications. These include stainless 062 MINSTAC connections (male and female), bent ports, and special flow rates.

Integral nozzles and safety screens can also be supplied as special parts.

Standard IEPA Valve Flowing Nitrogen

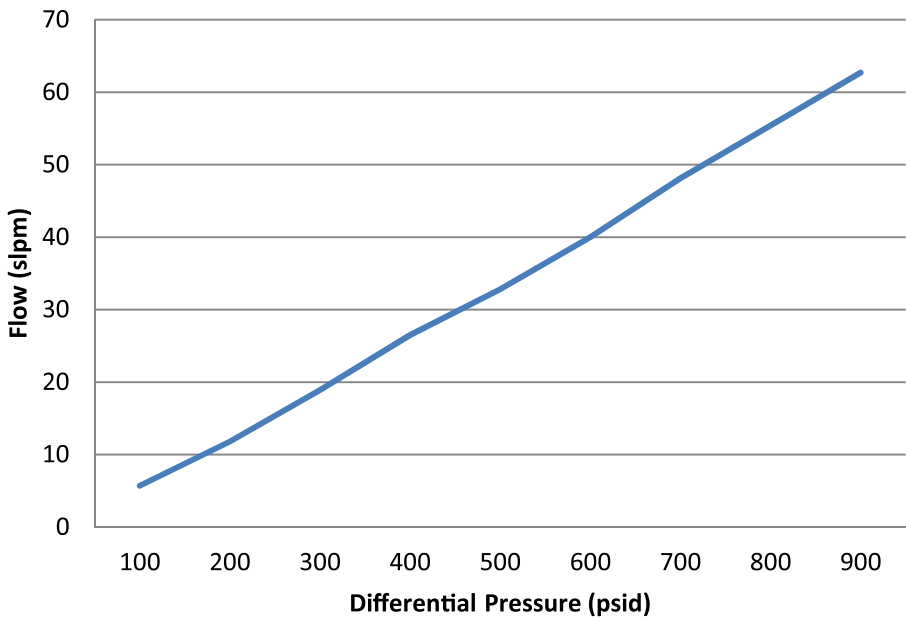

N

120 Series ***The World's Smallest Solenoid Valve***

Part Number LFLX0510200B



O

The Lee Series 120 Solenoid Valve is a 2-way, ultra-miniature, magnetically latched solenoid valve ideal for compact battery-powered pneumatic applications such as air piloting, lab automation (lab-on-a-chip), and other miniature, power-sensitive markets such as fuel cells or for R&D proof of concept projects.

The Series 120 valve sets a new industry standard in reducing space, weight and power consumption. Measuring just 0.4" long, the valve weighs 300 mg and requires only 1.8 mJ/switch. It also features high performance flow switching characteristics, reliable bi-stable performance and quiet operation.

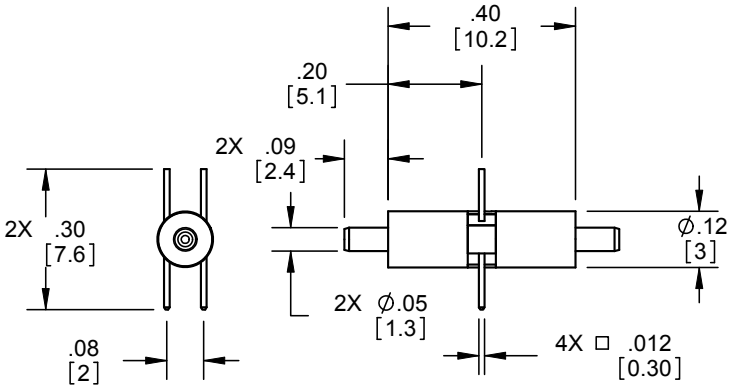

Unless otherwise specified, dimensions are in inches [mm].

Cross Section View

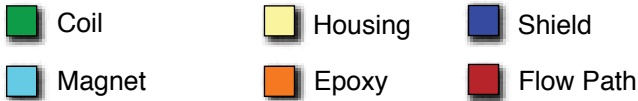
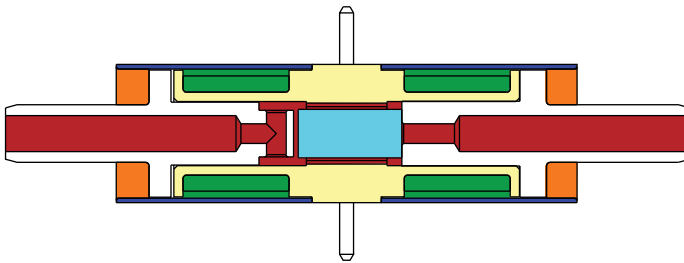

GENERAL SPECIFICATIONS

Flow Media	Air; Compatible Gases
Operating Voltage	5Vdc; 1ms Pulse to Switch (1.8 mJ/switch)
Flow Capacity (air)	5000 Lohms (1 SLPM @ 5 psid)
Operating Pressure	Vac-15 psig (0-5 psid)
Coil Resistance	14 Ohms @ 21°C
Weight	300 mg
Leakage	1 SCCM (max) at 5 psid
Max Frequency	10 Hz
Interface	Soft Tube Ported
Wetted Materials	PPS (Housing), Ceramic (Magnet), 430SS (Flow Ports & Shield), Epoxy

The Lee Visco-Jet[®] Micro-Mixer



P

The Lee Visco-Jet Micro-Mixer uses aerospace technology to provide the ultimate in static mixing efficiency. A series of 36 critically controlled spin chambers subject the incoming liquids to a vigorously repeated mixing process. No electrical or mechanical input is required – the mixing energy is drawn from the liquids themselves.

Two sizes are currently offered, differing primarily in their internal volume, to provide the user a selection to optimize system performance.

- Low Internal Volume – 10 μ L and 250 μ L Models
- Special Sizes as Small as 3 μ L Available
- Material – 316 Stainless Steel
- Maximum Flow – 45 mL/min. at 70°F 6,000 psid Water
- Screen Protected Passages
- Zero Dead Volume
- Proof-tested to 10,000 psi

Each mixing chamber induces tangentially spinning fluids to reduce their radius of rotation to allow passage into the next chamber, thus increasing angular velocity.

This rapidly spinning column of liquid must then reverse its own direction of rotation in order to progress to subsequent spin chambers.

The result is a vigorously repeated mixing process.



SPIN CHAMBER



MIXING ACTION

The mixing in a Lee Visco Mixer is a relatively brief process. As shown in the table below, the throughput time of the mixer is directly related to the flow rate. The more flow, the briefer the throughput time. It is during this throughput time that the two input flows are combined together for mixing.

FLOW ($\mu\text{L}/\text{min.}$)	THROUGHPUT TIME (SEC.)		PRESSURE DROP (psi)
	10 μL MIXER	250 μL MIXER	
50	12.0	300	.01
100	6.0	150	.04
200	3.0	75	.1
500	1.2	30	1.0
1000	.6	15	4.0
2000	.3	7	16.0
4000	.15	3	64.0

Any irregularities in either of the input flows will tend to be time averaged during the throughput time of the mixer.



10 μ L Model

Part Number TCMA0120113T

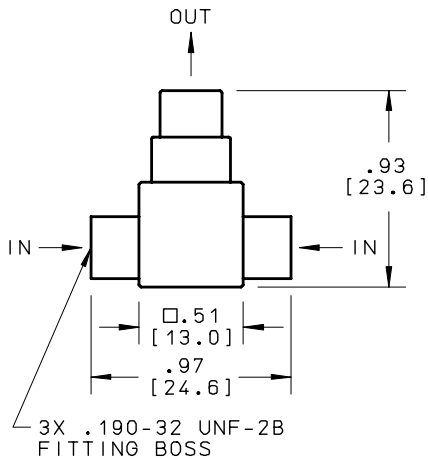

250 μ L Model

Part Number TCMA2520113T

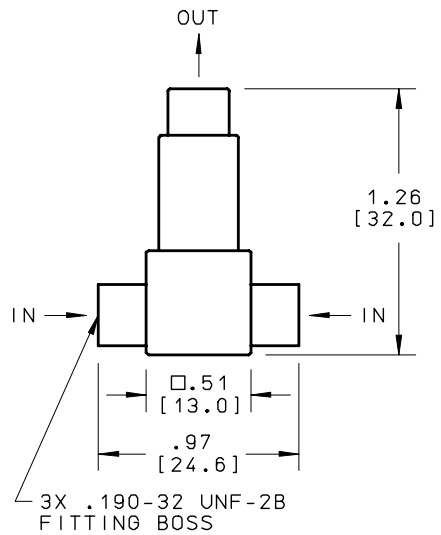

- Wetted Materials: 316 Stainless Steel
Au/Ni Braze per AMS 4787
- Proof Pressure: Tested to 10,000 psi
- Passage Size: 130 micron nominal
- Internal Protective Filtration: 17 μ nominal, 45 μ absolute
- Lohm Rate: 130,000 Lohms \pm 15%
- Internal Volume: 10 μ L and 250 μ L
- Fittings: Compatible with Swagelok® chromatography fittings
(tubing and couplings are customer supplied)

In-Line 10 μ L Model
Part Number TCMA0110113T

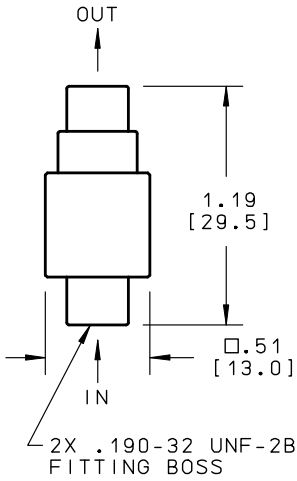

In-Line 250 μ L Model
Part Number TCMA2510113T

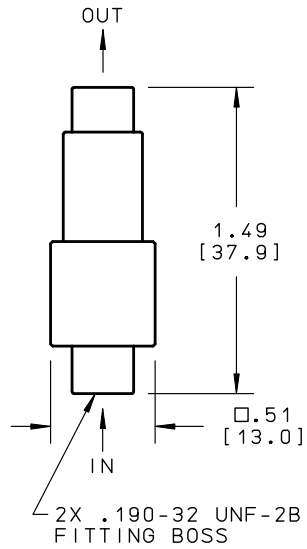

PART NUMBER	INTERNAL VOLUME	MATERIAL
TCMA0120113T	10 μ L	316 Stainless Steel
TCMA2520113T	250 μ L	316 Stainless Steel
TCMA0110113T	10 μ L	316 Stainless Steel
TCMA2510113T	250 μ L	316 Stainless Steel



Unless otherwise specified, dimensions are in inches [mm].

Operating Voltage Regulating Driver (OV'R Driver)

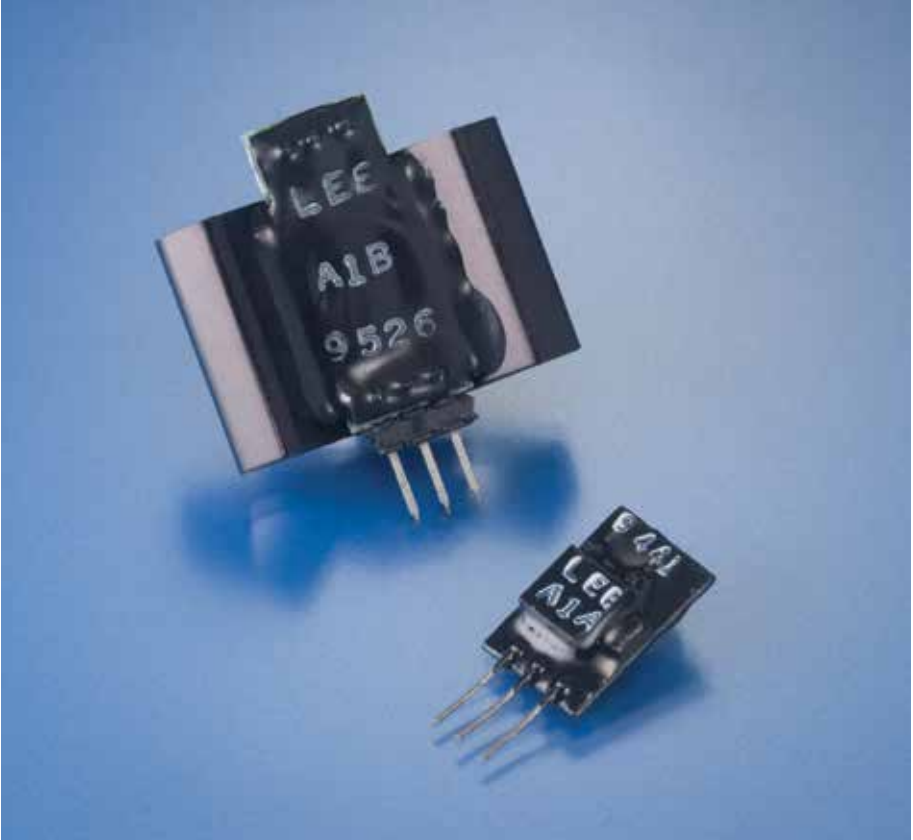

The OV'R Driver is a miniature electronic device which can be used to enhance the versatility and operating characteristics of solenoid valves. This circuit has a self-contained 'spike & hold' voltage controller, which allows the valve to be run at various voltages to compensate for fluctuations in power sources. This circuit can also be used to enhance a solenoid valve's response time or to reduce power consumption.

Q

- Solenoid valves operated at nominal voltages are automatically dropped to a lower 'holding' voltage resulting in lower power consumption.
- Fluctuations in input voltage levels are compensated, resulting in more consistent valve performance.
- Allows standard valves to be energized with a high voltage, reducing response time, and then held at a lower voltage thereby reducing heating.

Operation

The OV'R Driver is a simple three terminal device placed between the voltage source and the solenoid valve. Applying the input voltage to the circuit allows the solenoid to be energized by the OV'R Driver with approximately the full input voltage for a short time period. The circuit then reduces the voltage across the solenoid valve to the holding voltage level. The voltage across the valve will remain at this holding level until power is removed from the circuit. No additional control signals are necessary.

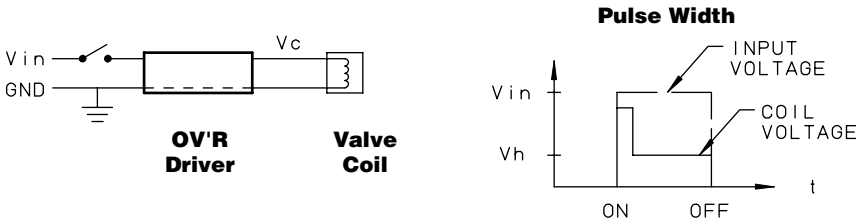

Both the spike duration and the holding voltage can be factory set to meet a variety of applications. The holding voltage, once set, is independent of the input voltage. The OV'R Driver can drive any solenoid valve up to 30 vdc and 15 Watts.

Pulse Width vs. Input Voltage

A key advantage of the OV'R Driver circuit is its ability to self-adjust the pulse width of the output spike voltage based on the input voltage level. As input voltage increases, the spike duration needed decreases. The holding voltage is unaffected by the input voltage level and since solenoid valves respond quicker at higher input voltages, the spike duration can be shortened, minimizing energy consumption, without affecting valve operation.

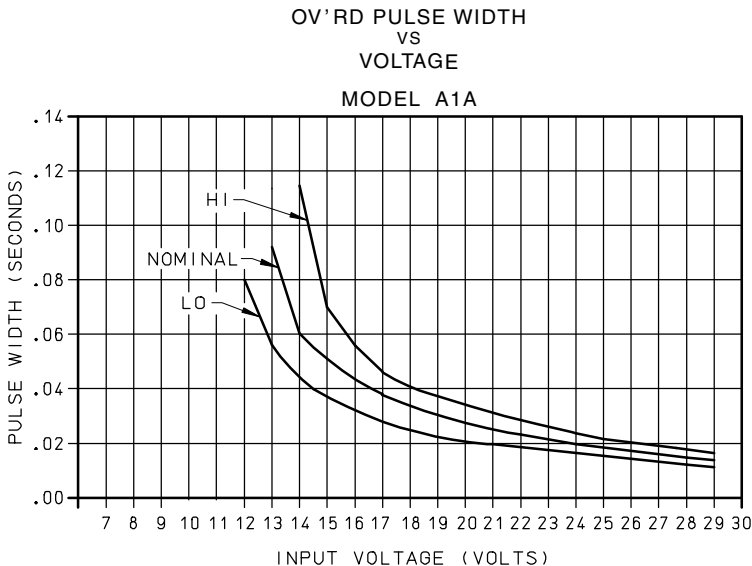

Models

The OV'R Driver is available in two standard configurations which are optimized for 12 vdc solenoid valves.

- Part Number DRVA0000010A – Designed to drive a single valve (less than 1 Watt)
- Part Number DRVA0000020A – Designed to drive multiple valves (15 Watt max total power). This design does not allow valves to be energized independently.

DRVA0000010A

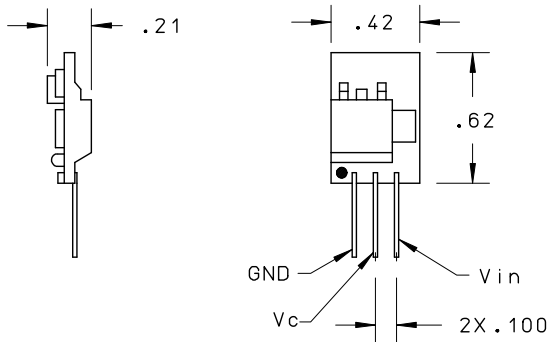

DRVA0000020A

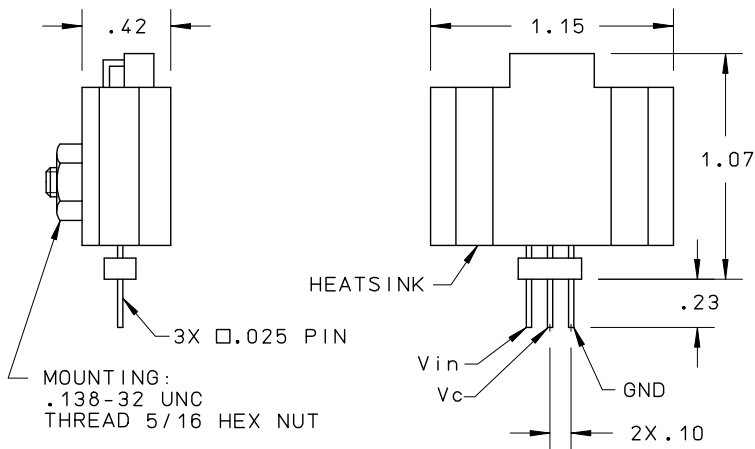

Unless otherwise specified, dimensions are in inches [mm].

OV'R Driver Operating Ranges

70° F, 100% duty cycle

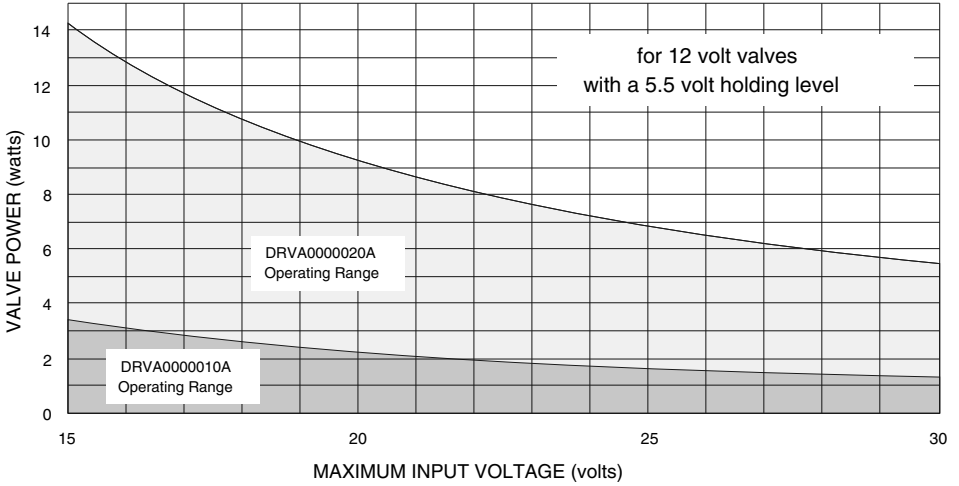

* A 15 volt minimum input voltage is recommended to make up for the small voltage drop across the O'VR Driver when using a 12 volt valve.

LSP Series Solenoid Valves



The LSP Series valve is a 2-way, manifold mounted, normally closed design featuring a full bore flow path. The full bore allows unimpeded high flow and is very tolerant of fluids that have particles and solids. The design minimizes clogging and leakage in applications such as waste and drain lines.

The flow path is a single wetted material incorporating flanged ports, thus eliminating the need for gaskets during mounting.

- Flow: 300 Lohms nominal
- Zero dead (unswept) volume
- Working pressure: 15 psig
- Response time: 30 ms
- Cycle life: 10 million cycles on clean water (minimum)
- Power consumption: 1.6 W
- Wetted material: FKM

PART NUMBER	OPERATING VOLTAGE
LSPA1242130D	12 vdc
LSPA2442130D	24 vdc

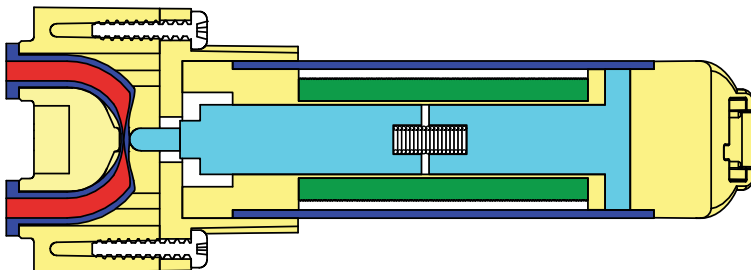

- Fluid
- Housing
- Coil
- Seal (elastomer tube)
- Shield
- Armature/Plunger Stop



LSP SERIES SOLENOID VALVES

SPECIAL PRODUCTS

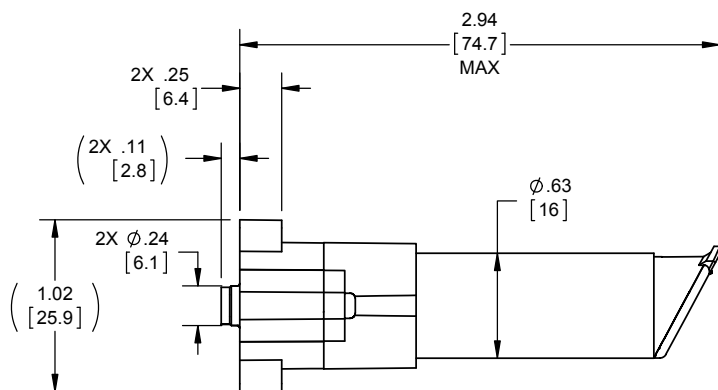
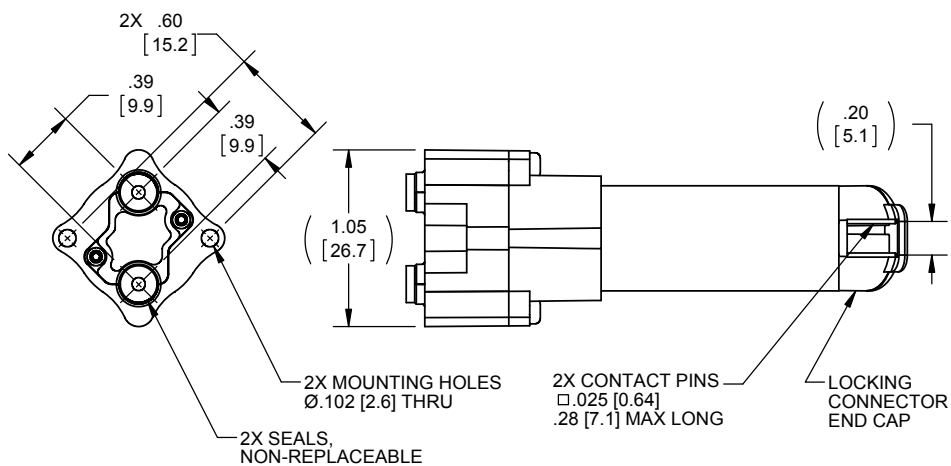

For manifold boss, use Lee Drawing LSIX1001450A

Typical Water Flow Characteristics

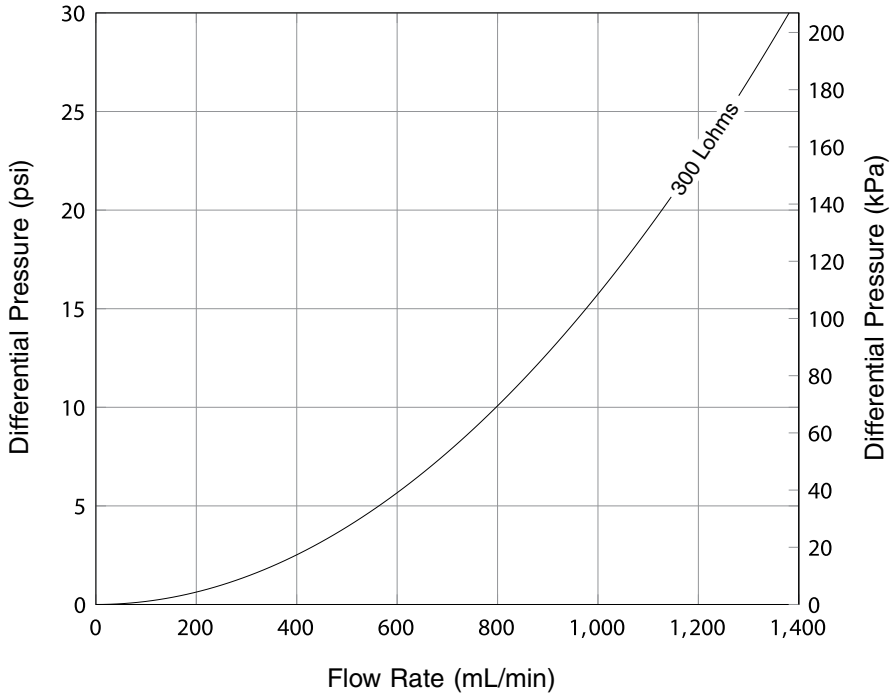



Lohm Laws

Definition..... S3
 Liquid Flow S4-5
 Liquid Flow – Units Constant K..... S6
 Viscosity “V” Factor..... S7
 Liquid Lohm Rate vs. Hole Diameter S8
 Liquid Flow Formulas S9-10
 Fluid Power Dissipation S11-12
 Gas vs. Liquid Calibration S13
 Gas Lohm Laws..... S14-20
 Gas Flow Rate of Various Air at Room Temperature S15
 Units Constant K – Volumetric / Gravimetric..... S18-20
 Absolute Pressure Measurement..... S21
 Gas Flow Characteristics / Momentum Forces..... S22-24
 Pneumatic Power Dissipation S25
 Gas Properties..... S26
 Transient Gas Flow S27-28

Tubing Flow

Resistance to Flow in Tubing S29
 Tubing Flow Curves S30-31
 Tubing Volume vs. Length S32

Contamination..... S33

Electrical Engineering

Ohm’s Law..... S34
 Lee Solenoid Coil Electrical Characteristics..... S35
 Basic Drive Circuit S36
 Spike and Hold Driver Schematic..... S37
 Fast Response Drive Circuit S38
 Low Power Consumption Circuit..... S39-40
 Latching Valve Driver Schematic S41-43

Reference Information

Primary Standards..... S44
 Conversion Factors S45-50
 Pressure Conversion Chart S48
 Viscosity S51-56
 Specific Gravity..... S57-58
 Torque Conversion..... S59
 Temperature Conversion..... S60
 Materials S61-62

Glossary S63-64

References S64

A Simplified System of Defining Fluid Resistance

Over the years, The Lee Company has developed the Lohm system for defining and measuring resistance to fluid flow. Just as the “ohm” defines electrical resistance, the “Lohm” or “liquid ohm” can be used as a measure of fluid resistance.

The Lohm is defined such that 1 Lohm will flow 100 gallons per minute of water with a pressure drop of 25 psi at a temperature of 80°F. Since resistance is inversely proportional to flow, by definition:

$$\text{Lohms} = \frac{100}{\text{flow (gal/min H}_2\text{O @ 25 psid)}}$$

1,000 Lohms will flow 0.1 GPM (378.5 mL/min.)

378,500 Lohms will flow 1 mL/min.

By using Lohms, one can specify performance without concern for coefficients of discharge, passageway geometries, physical dimensions or tolerances. The resistance of any flow configuration can be expressed in Lohms and confirmed by actual flow tests.

Lohm Laws generalize the Lohm definition for calculating the resistance required to flow any liquid or gas. Lohm Laws allow the system designer to determine Lohm requirements for a particular fluid with the desired pressures and flow rates. The graph on [page S8](#) will be helpful in relating Lohms to hole diameter and flow coefficient, C_v , during the introduction of the Lohm system.

LIQUID FLOW

The Lohm Laws predict the actual performance of fluidic devices beyond the definition conditions of water at 25 psid and 80°F. The Liquid Flow Lohm Law is shown below and the Gas Flow Lohm Law can be found on [page S16](#).

In Liquid Flow several variables must be related, including:

I = Flow rate

H = Differential pressure

V = Viscosity correction factor. V factors compensate for the interaction of viscosity and device geometry and are unique to each class of device. See [page S7](#) for a graph of "V" factors for typical Lee orifices.

S = Specific gravity

K = A constant to take care of units of measure.

See [page S6](#) for table of values

The Lohm Law for Liquid Flow is:
$$\text{Lohms} = \frac{KV}{I} \sqrt{\frac{H}{S}}$$

$$I = \frac{KV}{\text{Lohms}} \sqrt{\frac{H}{S}} \qquad H = \frac{\text{Lohms}^2 I^2 S}{K^2 V^2}$$

When testing with water at 25 psid ($\sqrt{H} = 5$), 80°F and flow rate in gallons per minute,

$$\text{Lohms} = \frac{100}{I} \qquad I = \frac{100}{\text{Lohms}}$$

Notes: 1. V and S are equal to 1 for water at 80°F

$$2. \text{Lohms} = \frac{20}{C_v} = \frac{.67}{C_d d^2} \qquad \text{and} \qquad C_v = 30 C_d d^2$$

d = orifice diameter (inches)

C_d = coefficient of discharge

C_v = flow coefficient

For special flow requirements, The Lee Company can determine the required Lohm rating.

LIQUID FLOW – EXAMPLES

Problem 1. A restrictor is required to flow 0.1 GPM of 50/50 ethylene glycol/water blend (specific gravity = 1.07) at 45°F and 6 psid. How many Lohms are required?

Solution:

1. Read kinematic viscosity; $\nu = 5.0$ cs from curve on [pages S53-54](#).
2. Use ν and ΔP to determine viscosity correction factor, $V = .87$, from curve on [page S7](#).
3. Select unit constant K from table on [page S6](#).
4. Compute Lohms required.

$$L = 20 \frac{V}{I} \sqrt{\frac{H}{S}} = 20 \frac{.87}{.1} \sqrt{\frac{6}{1.07}} = 412 \text{ Lohms}$$

Problem 2. What pressure drop will result from a flow of 57 mL/min. of 50/50 ethylene glycol/water mixture (specific gravity = 1.07) at 45°F, flowing through a 1000 Lohm restrictor?

Solution:

1. Find viscosity from [pages S53-54](#). $\nu = 5$ cs
2. Use knowledge of system to assume initial solution.
 $H = 4$ psid
3. Use assumed H to determine $V = 0.75$ from table on [page S7](#).
4. Select units constant K from table on [page S6](#).
5. Compute trial ΔP

$$H = S \frac{I^2 L^2}{K^2 V^2} = 1.07 \cdot \left(\frac{57 \cdot 1000}{75700 \cdot .75} \right)^2 = 1.08 \text{ psid}$$

6. Make trials as required to find correct solution.
 $H = 2$ psid $V = .55$

LIQUID FLOW – UNITS CONSTANT K

S

To eliminate the need to convert pressure and flow parameters to specific units such as PSI and GPM, the units constant K may be used in the Lohm formula:

$$L = \frac{KV}{I} \sqrt{\frac{H}{S}}$$

FLOW UNITS	PRESSURE UNITS						
	psi	bar	kPa	N/m ²	kg/cm ²	ft.H ₂ O	mm/Hg
gpm	20	76.2	7.62	.24	75.4	13.2	2.78
L/min.	75.7	288	28.8	.91	285	50	10.5
mL/min.	75,700	288,000	28,800	911	285,000	50,000	10,500
in ³ /min.	4,620	17,600	1,760	55.6	17,400	3,040	642
ft ³ /min.	2.67	10.2	1.02	.032	10	1.76	.372

Example: Problem: An orifice must flow 43 in.³/min. of water at a head of 300 kPa.
What Lohm rate is required?

Solution: First, the appropriate K is selected from the table: K = 1,760.
Second, the Lohm Formula is solved using the K value:

$$L = \frac{1760 \sqrt{300}}{43} = 709 \text{ Lohms } (S = V = 1.0)$$

**VISCOSITY CORRECTION FACTOR "V"
For Single Orifice**

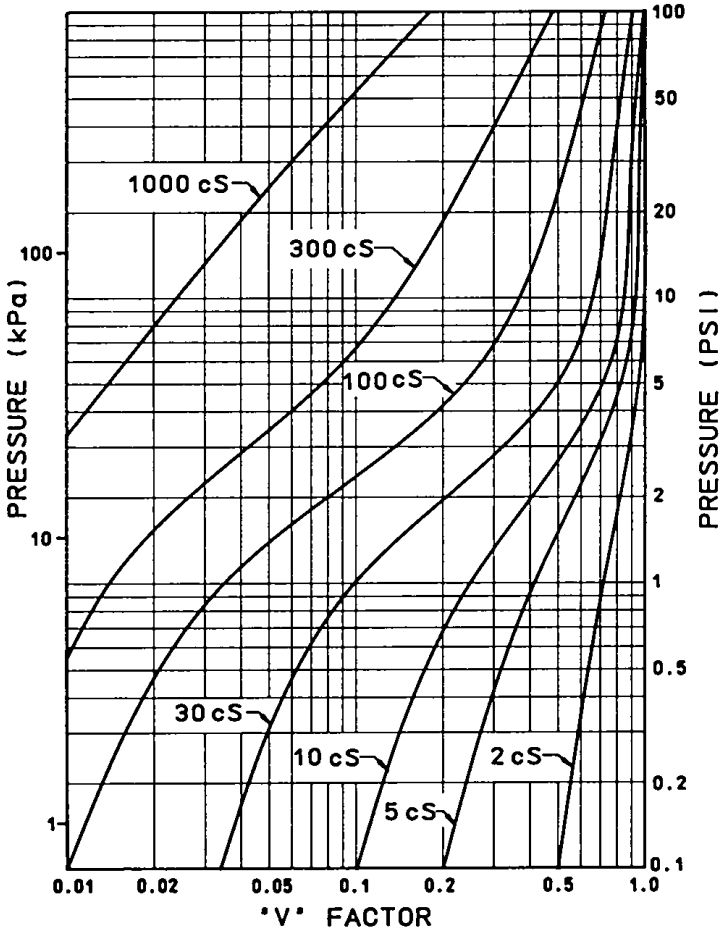

Note: "V" Factor Curve may vary depending on specific geometry of the device.

LIQUID LOHM RATE VERSUS HOLE DIAMETER (Single Orifice Restrictor)

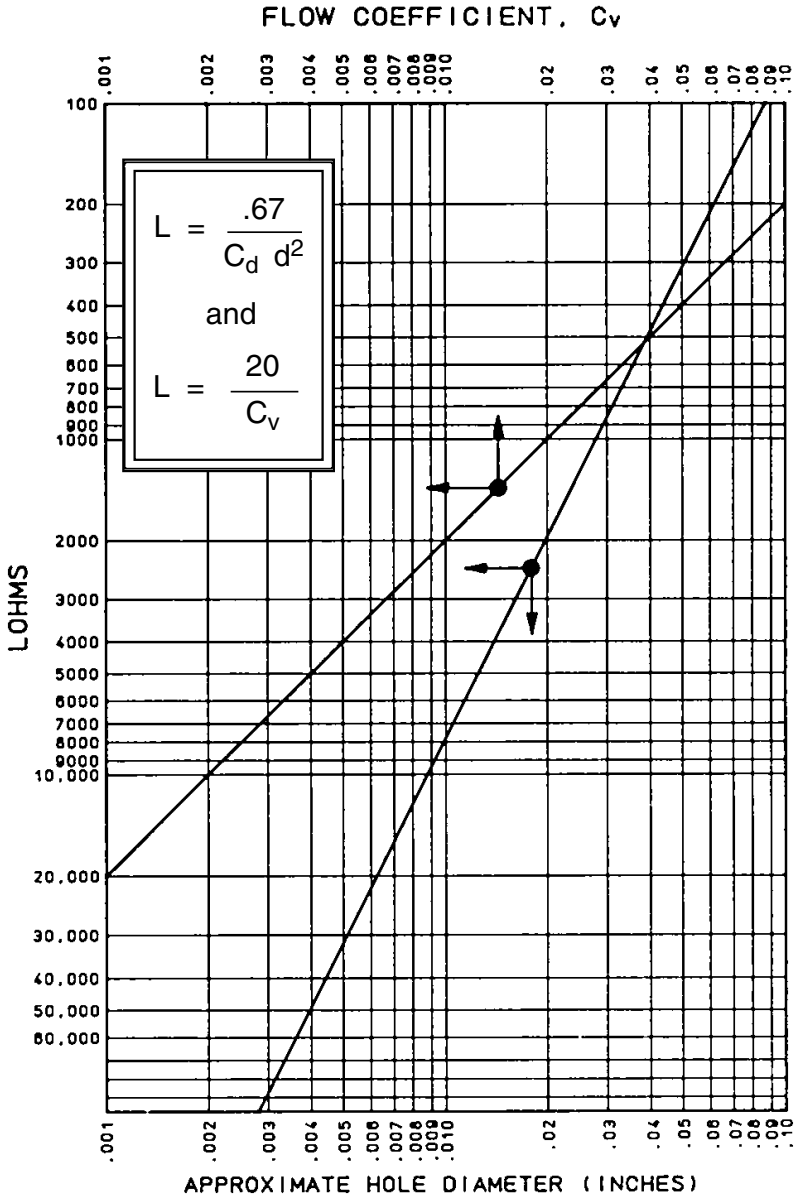

GRAPHICAL EXTENSION
 .500 DIA. = 3 LOHMS .250 DIA. = 12 LOHMS .025 DIA. = 1200 LOHMS

LIQUID FLOW – TWO FORMULAS FOR COMBINATIONS OF RESTRICTORS

For parallel flow, the total Lohm rating is:

$$\frac{1}{L_T} = \frac{1}{L_1} + \frac{1}{L_2} + \frac{1}{L_3} + \dots + \frac{1}{L_N}$$

Please note that this relationship is identical to the electrical equation.

Example:

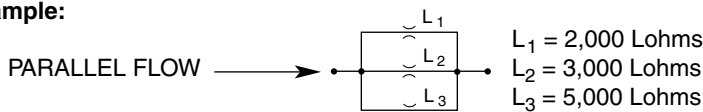

$$\frac{1}{L_T} = \frac{1}{2000} + \frac{1}{3000} + \frac{1}{5000} = .00103 \text{ and therefore } L_T = 970 \text{ Lohms}$$

For Series Flow, the total Lohm rating is:

$$L_T = \sqrt{L_1^2 + L_2^2 + L_3^2 + \dots + L_N^2}$$

Please note that this relationship is not the same as in electrical problems. The difference is due to the non-linearity of

$$H = \frac{I^2 L^2 S}{K^2 V^2}$$

Example:



$$L_T = \sqrt{2,000^2 + 3,000^2 + 5,000^2} = 6,164 \text{ Lohms}$$

When $L_1 = L_2 = L_3$, then $L_T = L\sqrt{N}$

N = Number of equal restrictors in series

For passageway size: $D_T = \frac{D}{N^{1/4}}$

D = Diameter of the actual orifices, each with a Lohm rate = L_1

D_T = Diameter of a single equivalent orifice, with a Lohm rate = L_T

MOMENTUM FORCES – LIQUID FLOW

The momentum Lohm Laws give the designer simple formulas to determine the forces caused by changes in velocity (either speed or direction) of a liquid.

$$F = \frac{SI^2L}{400} \qquad F = \frac{H}{L} \qquad F = \frac{I \sqrt{HS}}{20}$$

F = Force in lbs. H = psid I = GPM S = Spec. gravity

These forces are produced by locally high (or low) pressure gradients, and should be added to the forces produced by the static pressure. It is often useful to sketch these pressure gradients to determine the direction of the momentum forces.

EXAMPLE: Where a liquid changes direction.

$$F_{\text{momentum}} = \frac{H}{L} = \frac{990}{600} = 1.7 \text{ lbf}$$

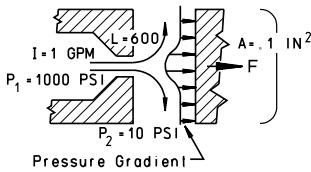

The momentum force of 1.6 lbs. in this example must be added to the force produced by static pressure on the plate (of .1 in.² x 10 psi = 1 lb.) to give the total force on the plate.

EXAMPLE: Where a liquid changes speed.

$$F_{\text{momentum}} = \frac{SI^2L}{400} = \frac{1 \times 2^2 \times 100}{400} = 1 \text{ lbf}$$

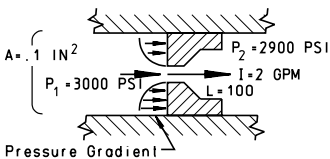

The momentum force of 1lb. in this example must be subtracted from the force produced by static pressure on the plate (of 0.1 x [3000-2900] = 10 lb.) to give the total force on the piston.

FLUID POWER DISSIPATION

S

Whenever there is flow through an orifice, there is a power consumption (or loss) which is a function of the pressure drop and the flow rate. The following data is useful in calculating the hydraulic power requirements of a system.

$$\text{H.P.} = \frac{H \times I}{1714} \quad \begin{array}{l} \text{When } H = \text{psi } \Delta P \\ I = \text{GPM flow rate} \end{array}$$

The hydraulic power can also be expressed in another convenient form.

$$\text{H.P.} = \frac{0.0117 H^{3/2}}{L} \quad \text{or} \quad \frac{0.0117 H \sqrt{H}}{L}$$

Since 1 H.P. = 746 watts, the above formula can be:

$$\text{Watts} = \frac{8.70 H^{3/2}}{L} \quad \text{or} \quad \frac{8.70 H \sqrt{H}}{L}$$

The nomogram on the next page shows this relationship.

EXAMPLE:

A Lee Valve rated at 400 Lohms will flow 0.35 GPM at 50 psid. At those conditions, what horsepower is lost?

$$\text{H.P.} = \frac{H \times I}{1714} = \frac{50 \times 0.35}{1714}$$

$$\text{H.P.} = 0.010$$

NOMOGRAM for FLUID POWER DISSIPATION

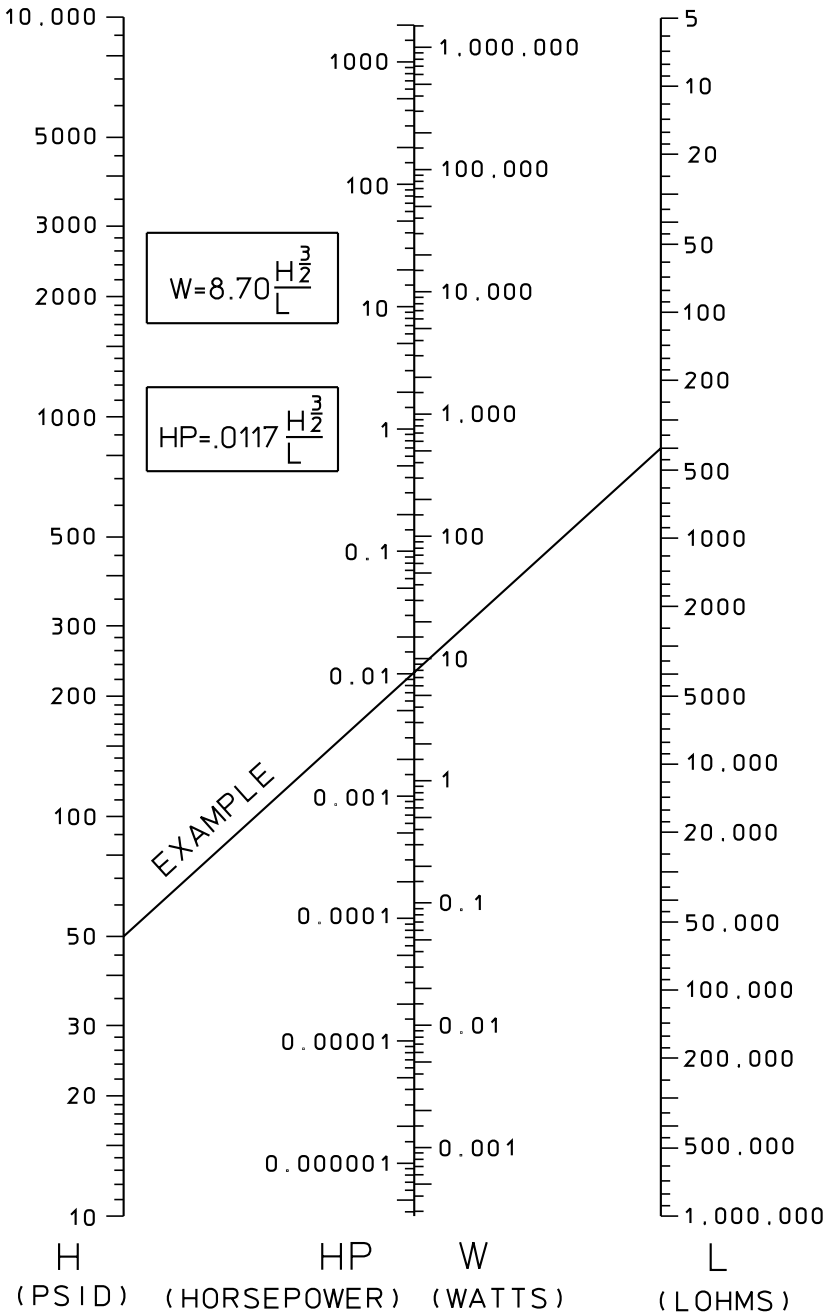

S

GAS vs. LIQUID CALIBRATION

Most EFS products are calibrated on gas for both gas and liquid service. Should it be necessary to use a gas calibrated component for liquid service, or a liquid calibrated component for gas service, the following factors should be considered.

Allowance should be made for variations in liquid/gas correlation of up to $\pm 15\%$. This is caused by the response of different fluids to the orifice geometry.

Single-orifice restrictors will correlate directly from gas to liquid service, subject to the $\pm 15\%$ normal variation.

Multi-orifice restrictors will correlate directly only when the pneumatic pressure ratio is very low ($P_1 / P_2 < 1.2$).

When Multi-orifice restrictors are used at higher pressure ratios, the gas flow will be up to 30% higher than expected from a liquid calibration. This is caused by gas compressibility which results in a non-uniform distribution of pressure drops through the restrictor.

WARNING: Do not substitute hydraulic restrictors in gas applications, or vice versa, without first considering the application and correlation accuracy.

STANDARD CONDITIONS

U.S. Standard Conditions at sea level are per ICAO STD ATMOSPHERE

Pressure 14.70 psia (29.92 in. Hg)

Temperature 59°F (518.7°R)

Other References may use somewhat different conditions.

GAS FLOW ACFM TO SCFM CONVERSION

It is frequently convenient to express gas flow in terms of flow at standard conditions. This is useful for calculation purposes, or for application to flow measuring instruments.

$$\text{SCFM} = \text{ACFM} \left(\frac{P}{14.7} \right) \left(\frac{519}{T} \right)$$

UNITS:

T = Gas temperature, °R = 460 + °F

P = Gas pressure, psia

ACFM = Gas flow, actual cubic feet/minute

SCFM = Gas flow, standard cubic feet/minute

EXAMPLE: What is SCFM corresponding to 0.032 ACFM at 300 psia and at 240°F?

SOLUTION:

$$\text{SCFM} = 0.032 \left(\frac{300}{14.7} \right) \left(\frac{519}{700} \right) = 0.48$$

LOHM LAWS (GAS)

Every engineer will be interested in our simple system of defining the fluid resistance of Lee components. Just as the OHM is used in the electrical industry, we find that we can use the Liquid OHM or "Lohm" to quantify the restriction of hydraulic or pneumatic components.

When using the Lohm system for pneumatics, the effect of flow in the subsonic region and the compressibility of gases is corrected for in the Lohm calculations. The resistance to flow of any component can be expressed in Lohms.

The Lohm has been selected so that a 100 Lohm restriction will permit a flow of 250 standard liters per minute of nitrogen at a temperature of 59°F, and an upstream pressure of 90 psia discharging to atmosphere.

The graph on the following page relates Lohms to hole diameter for a single orifice restrictor.

GAS FLOW RATE OF VARIOUS RESTRICTION AIR AT ROOM TEMPERATURE

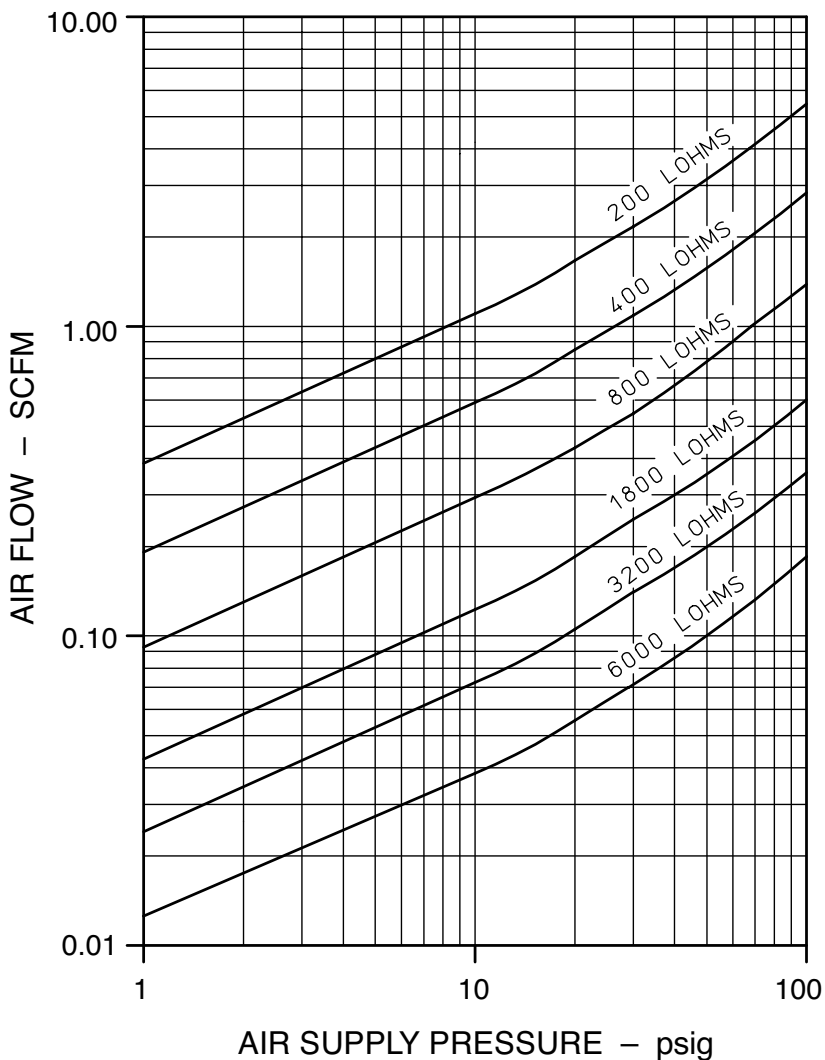

The Lohm Laws extend the definition of Lohms for gas flow at any pressure and temperature, and with any gas. The formulas work well for all gases because they are corrected for the specific gas, and for the flow region and incompressibility of low pressure gases.

The Lohm Law for Gas Flow is:

$$\text{Lohms} = \frac{K f_T P_1}{Q} \quad \begin{array}{l} \text{(Sonic region)} \\ \text{i.e. } P_1/P_2 \geq 1.9 \end{array}$$

$$\text{Lohms} = \frac{2 K f_T \sqrt{\Delta P} P_2}{Q} \quad \begin{array}{l} \text{(Subsonic region)} \\ \text{i.e. } P_1/P_2 < 1.9 \end{array}$$

NOMENCLATURE

K = Gas units constant (see [pages S18-19](#))

f_T = Temperature correction factor (see [page S17](#))

P_1 = Upstream absolute pressure (psia)

P_2 = Downstream absolute pressure (psia)

Q = Gas flow (std L/min.)

$\Delta P = P_1 - P_2$ (psid)

All you have to do is:

Compute the P_1/P_2 pressure ratio.

Select the correct formula for the flow region.

Look up the value of "K" for the gas.

Look up the temperature correction factor, " f_T ".

Use the formula to solve for the unknown.

TEMPERATURE CORRECTION FACTOR

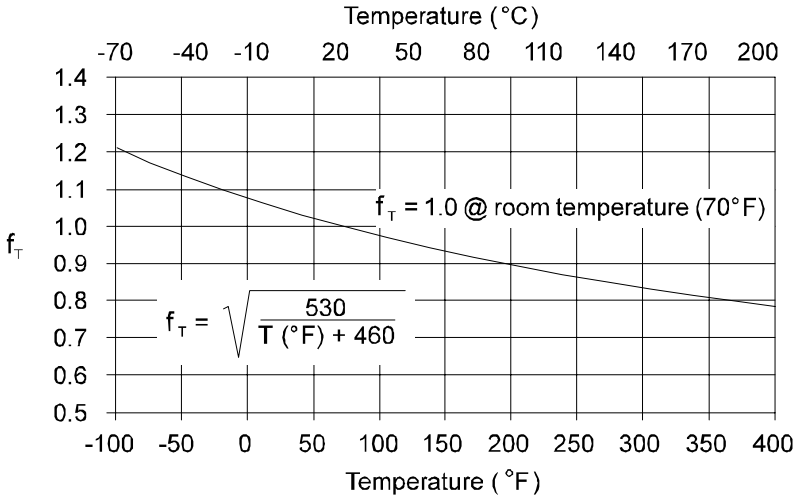

LOHM LAWS - GAS FLOW

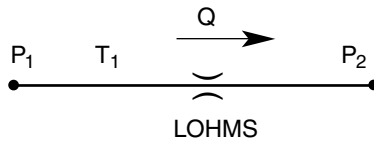

EXAMPLE: What restriction will permit a flow of 1.00 std L/min. of nitrogen at 90°F, with supply pressure at 5 psig, discharging to atmosphere?

$K = 276$ (see pages S18-19)

$T_1 = 90$ $f_T = 0.98$

$P_1 = 5.0 + 14.7 = 19.7$ psia, $P_2 = 14.7$ psia

$P_1/P_2 = 19.7/14.7 = 1.34$ (subsonic)

$\Delta P = 5.0$ psid

$Q = 1.00$ std L/min.

$$L = \frac{2 \times 276 \times 0.98 \times \sqrt{5.0 \times 14.7}}{1.00} = 4,640 \text{ Lohms}$$

UNITS CONSTANT “K” – VOLUMETRIC

To eliminate the need to convert pressure and flow parameters into specific units such as “psia” and “std L/min.,” the table below lists values of the Units Constant “K,” which is used in the Gas Flow Lohm Formula:

$$\text{Lohms} = \frac{K f_T P_1}{Q} \quad (\text{Sonic})$$

VOLUMETRIC FLOW UNITS							
Abs. Pres	psia			bar		kPa	mm/Hg
FLOW	SLPM	SCFM	ln ³ /min	SLPM	SCFM	SLPM	mL/min
H ₂	1030	36.3	62,700	14,900	526	149	19,900
He	771	27.2	47,100	11,200	395	112	14,900
Neon	343	12.1	20,900	4,980	176	49.8	6,640
Nat. Gas	319	11.3	19,400	4,620	163	46.2	6,160
N ₂	276	9.730	16,800	4,000	141	40.0	5,330
CO	274	9.69	16,700	3,980	141	39.8	5,300
Air	271	9.56	16,500	3,930	139	39.3	5,230
Ethane	251	8.86	15,300	3,640	129	36.4	4,850
O ₂	257	9.08	15,700	3,730	132	37.3	4,970
Argon	245	8.65	14,900	3,550	125	35.5	4,730
CO ₂	213	7.52	13,000	3,090	109	30.9	4,110
N ₂ O	214	7.56	13,100	3,100	110	31.0	4,140
SO ₂	176	6.21	10,700	2,550	90.1	25.5	3,400
Freon-12	123	4.34	7,510	1,780	63.0	17.8	2,380

UNITS CONSTANT "K" - GRAVIMETRIC

See examples on [page S20](#) of using the Units Constant "K" with flow specified in either volume or weight units.

$$\text{Lohms} = \frac{K f_T P_1}{w}$$

(Sonic)

GRAVIMETRIC FLOW UNITS							
Abs. Pres	psia			bar		kPa	mm/Hg
FLOW	PPH	lb _m /s	kg/min	PPH	kg/min	kg/min	gm/min
H ₂	11.6	0.00322	0.0876	168	1.27	0.0127	1.27
He	17.3	0.00479	0.131	250	1.89	0.0189	2.52
Neon	38.7	0.0108	0.293	561	4.25	0.0425	5.66
Nat. Gas	34.8	0.00966	0.263	505	3.82	0.0382	5.09
N ₂	43.2	0.0120	0.326	626	4.73	0.0473	6.31
CO	43.0	0.0119	0.325	623	4.71	0.0471	6.28
Air	43.8	0.0122	0.331	636	4.81	0.0481	6.41
Ethane	42.2	0.0117	0.319	611	4.62	0.0462	6.16
O ₂	46.0	0.0128	0.348	667	5.04	0.0504	6.72
Argon	54.6	0.0152	0.413	792	5.99	0.0599	7.99
CO ₂	52.4	0.0145	0.396	759	5.74	0.0574	7.65
N ₂ O	52.7	0.0146	0.398	764	5.77	0.0577	7.70
SO ₂	63.0	0.0175	0.476	914	6.91	0.0691	9.21
Freon-12	83.2	0.0231	0.629	1,210	9.12	0.0912	12.2

UNITS CONSTANT “K”

EXAMPLE: A restrictor must flow 8.20 std L/min. of helium at room temperature (70°F), with an inlet pressure of 1,500 kPa, discharging to atmosphere. What Lohm rate is required?

$$K = 112 \text{ (see pages S18-19)}$$

$$T_1 = 70^\circ\text{F}, f_T = 1.00 \text{ (see page S17)}$$

$$P_1 = 1,500 \text{ kPa}, P_2 = 101 \text{ kPa}$$

$$P_1/P_2 = 14.9 \text{ (sonic)}$$

$$Q = 8.20 \text{ std L/min.}$$

$$L = \frac{112 \times 1,500 \times 1.00}{8.20} = 20,500 \text{ Lohms}$$

EXAMPLE: A restrictor must flow 0.0015 lb_m/s of oxygen at room temperature (70°F), with an inlet pressure of 1,200 psia, discharging to 850 psia. What Lohm rate is required?

$$K = 0.0128 \text{ (see pages S18-19)}$$

$$T_1 = 70^\circ\text{F}, f_T = 1.00$$

$$P_1 = 1,200 \text{ psia.}, P_2 = 850 \text{ psia.}$$

$$P_1/P_2 = 1.41 \text{ (subsonic)}$$

$$\Delta P = 350 \text{ psid.}$$

$$w = 0.0015 \text{ lb}_m/\text{s}$$

$$L = \frac{2 \times 0.0128 \times 1.00 \times \sqrt{350 \times 850}}{0.0015} = 9,300 \text{ Lohms}$$

ABSOLUTE PRESSURE MEASUREMENT

Gas flow is a function of upstream absolute pressure, and of the ratio of upstream to downstream pressures. Lohm testing done at The Lee Company is performed at an upstream pressure which is high enough so that downstream pressure does not affect the flow rate. To accurately determine the upstream absolute pressure, it is necessary to measure atmospheric pressure with a suitable barometer. This measurement will normally be in units of in. Hg, while the gauge pressure reading is in units of psig. Thus, the barometer reading must be converted to psia, and added to the gauge reading to get the value of pressure in psia.

$$\text{Pres. (psia)} = \text{Pres. (psig)} + 0.4912 \times \text{Pres. (in. Hg @ 32°F.)}$$

EXAMPLE: What single-orifice restriction will permit a flow of 2.00 std L/min. of nitrogen at 70°F, with supply pressure at 10 psig, discharging to an atmospheric pressure of 29.5 in. Hg.

$$K = 276 \text{ (see pages S18-19)}$$

$$T_1 = 70^\circ\text{F}, f_T = 1.00 \text{ (see page S17)}$$

$$P_2 = 0.4912 \times 29.5 = 14.5 \text{ psia.}$$

$$P_1 = 10.0 + 14.5 = 24.5 \text{ psia.}$$

$$P_1/P_2 = 24.5/14.5 = 1.69 \text{ (subsonic)}$$

$$\Delta P = 24.5 - 14.5 = 10.0 \text{ psid.}$$

$$Q = 2.00 \text{ std L/min}$$

$$L = \frac{2 \times 276 \times 1.0 \times \sqrt{10.0 \times 14.5}}{2.00} = 3,320 \text{ Lohms}$$

GAS FLOW CHARACTERISTICS

When selecting components for use in a gas system, certain factors must be considered which arise only because of the compressibility of the gaseous medium. The nature of gas compressibility is defined by the following two rules:

- Boyle's Law – The pressure and specific volume of a gas are inversely proportional to each other under conditions of constant temperature.
- Charles' Law – The pressure and temperature of a gas are directly proportional to each other when the volume is held constant, and the volume and temperature are directly proportional when the pressure is held constant.

Thus, a gas will expand to fill any container, and pressure and temperature will adjust to values consistent with the above rules. Gas flowing through valves and restrictors will be subject to an increasing specific volume as pressure drops take place, and temperatures will change as determined by the Joule-Thomson effect.

The combination of the above rules forms the basis for the "Equation of State" for perfect gases. This allows either pressure, temperature, or volume to be calculated for a known quantity of gas when the other two variables are known.

i.e. $p V = m R T$ (see [page S26](#) for values of gas constant, R)

In general, the following comments apply to gas flow:

1. Gas flow at high pressure ratios ($P_1/P_2 > 1.9$) is directly proportional to the upstream absolute pressure.
2. Gas flow at moderate pressure ratios ($1.1 < P_1/P_2 < 1.9$) is proportional to the downstream absolute pressure, and to the pressure differential (see [page S16](#)).

Continued on next page.

GAS FLOW CHARACTERISTICS (continued)

3. Gas flow at low pressure ratios ($P_1/P_2 < 1.1$) is proportional to the pressure differential, similar to hydraulic flow.
4. When restrictions appear in series, the most downstream restrictor dominates in the determination of flow rate.
5. When the absolute pressure ratio across a restrictor is above 1.9, the gas velocity will reach the speed of sound (sonic flow) in the restrictor throat. When restrictors appear in series the overall pressure ratio must be even higher.
6. When equal restrictors appear in series, sonic flow can only occur in the most downstream restrictor.
7. Velocity of the gas stream cannot exceed the speed of sound in either a constant area duct, or a converging section.

The Rule of Forbidden Signals: *

“The effect of pressure changes produced by a body moving at a speed faster than the speed of sound cannot reach points ahead of the body.”

This rule can be applied to pneumatic flow restrictors where the body is not moving, but the flow velocity relative to the body can reach, or exceed, the speed of sound. Whenever the downstream pressure is low enough to produce Mach 1 at the restrictor throat, any effect of changes in the downstream pressure cannot reach points upstream of the throat. Thus, flow rate will be independent of downstream pressure. This situation applies to a single orifice restrictor flowing air when the overall pressure ratio exceeds 1.89/1

* von Kármán, Jour. Aero. Sci., Vol. 14, No. 7 (1947)

MOMENTUM FORCES – GAS FLOW

When a flowing stream of gas is subject to a change in velocity (either speed or direction), forces arise which are the reaction to the change in momentum of the stream. This is particularly important in valve design where the position of a moving element may be affected.

The direction in which the momentum force acts is always opposite to the acceleration which is imparted to the flow stream. The magnitude of the force may be calculated by using the momentum Lohm Laws which apply to air at near room temperature.

$$F = \frac{0.4 \times P_1}{L} \quad F = \frac{\text{SLPM}}{700} \quad (\text{sonic flow})$$

EXAMPLE: Where a gas changes direction.

$$F = \frac{0.4 \times P_1}{L} = \frac{0.4 \times 1000}{2000} = 0.2 \text{ lbf.}$$

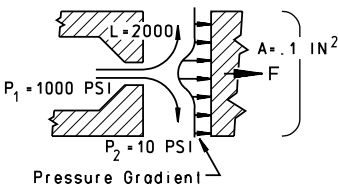

The momentum force of 0.2 lbs. in this example must be added to the force produced by static pressure on the plate ($0.1 \text{ in.}^2 \times 10 \text{ psi} = 1 \text{ lb.}$) to give the total force on the plate.

EXAMPLE: Where a gas changes speed.

$$F = \frac{\text{SLPM}}{700} = \frac{35}{700} = 0.05 \text{ lbf.}$$

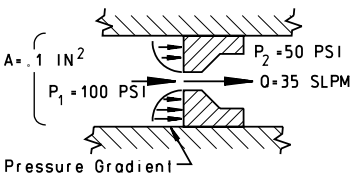

The momentum force of 0.05 lb. in this example must be subtracted from the force produced by static pressure on the plate ($0.1 \text{ in.}^2 \times [100-50] = 5 \text{ lb.}$) to give the total force on the piston.

PNEUMATIC POWER DISSIPATION

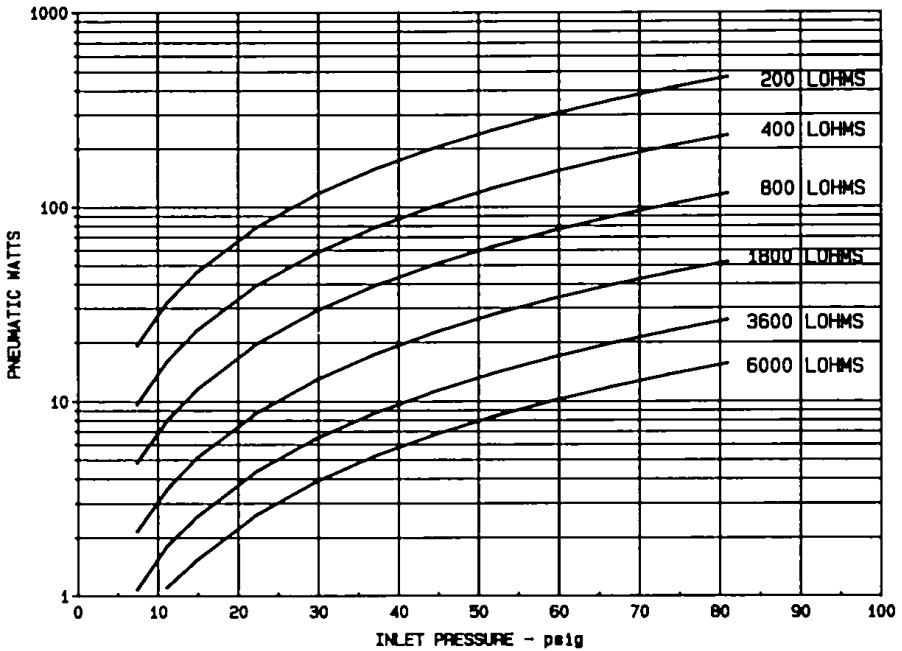

For more precise calculations, or to extend the range of the pneumatic power dissipation graph, the following formula may be used for air.

$$\text{Watts} = \frac{1,641 P_1}{L} \left[\left(\frac{P_1}{P_2} \right)^{1/4} - 1 \right]$$

P_1 = Supply Pressure (psia)

P_2 = Exhaust Pressure (psia)

L = Lohm Rate

Note that due to compressor inefficiencies, more energy will be needed to compress the air than will be expended when it flows through an orifice.

GAS PROPERTIES

S

GAS	k	R ft lb/lb°R	DENSITY		cdP* Btu/lb°R	cdV* Btu/lb°R
			lb _m /ft ³	lb _m /std L		
H ₂	1.40	766.6	0.00532	0.000188	3.420	2.435
He	1.66	386.1	0.01056	0.000373	1.250	0.754
Neon	1.66	76.6	0.0533	0.00188	0.248	0.150
Nat. Gas	1.22	79.2	0.0516	0.00182	0.560	0.458
N ₂	1.40	55.2	0.0739	0.00261	0.247	0.176
CO	1.41	55.2	0.0739	0.00261	0.243	0.172
Air	1.40	53.3	0.0764	0.00270	0.241	0.173
Ethane	1.21	51.4	0.0793	0.00280	0.386	0.320
O ₂	1.40	48.3	0.0845	0.00298	0.217	0.155
Argon	1.67	38.7	0.1053	0.00372	0.124	0.074
CO ₂	1.28	35.1	0.1162	0.00410	0.205	0.160
N ₂ O	1.26	35.1	0.1162	0.00410	0.221	0.176
SO ₂	1.25	24.1	0.1691	0.00597	0.154	0.123
Freon-12	1.13	12.8	0.319	0.01127	0.145	0.129

*values at 68°F and 14.7 psia

c_p = Specific heat at constant pressure

c_v = Specific heat at constant volume

k = Ratio of specific heats, $\frac{c_p}{c_v}$

R = Gas Constant, $\frac{R}{\text{Molecular. Wt.}}$

S

TRANSIENT GAS FLOW

This type of flow normally concerns the charging of a volume through a fixed resistance such as an orifice. Use of the Lohm system simplifies the calculation of the time required to blow down or charge up a vessel.

The first step is to calculate system time constant, τ , which takes into consideration the type of gas, pressure–vessel volume, absolute temperature, and flow resistance. The time constant is given by:

$$\tau = \frac{4 f_T V L}{K}$$

Note: Select K from the appropriate “psia” column of the Volumetric Flow Table on page S18. Keep the units of pressure vessel volume (V) consistent with the volumetric flow units.

The larger the value of τ , the more sluggish the system.

Once τ has been calculated, the ratio of upstream pressure to downstream pressure for both the initial and final conditions must be computed. Then, from the pressure–ratio graph, initial and final values for N can be found. N is the number of system time constants required for the system to reach equilibrium.

If the final condition is equilibrium, where upstream and downstream pressures are equal, the final pressure ratio is 1 and the final value of N is 0. With these values, the time for the system to blow down or charge up can be calculated from:

$$t = \tau (N_i - N_f) \quad t = \text{Time (sec.)}$$

TRANSIENT GAS FLOW

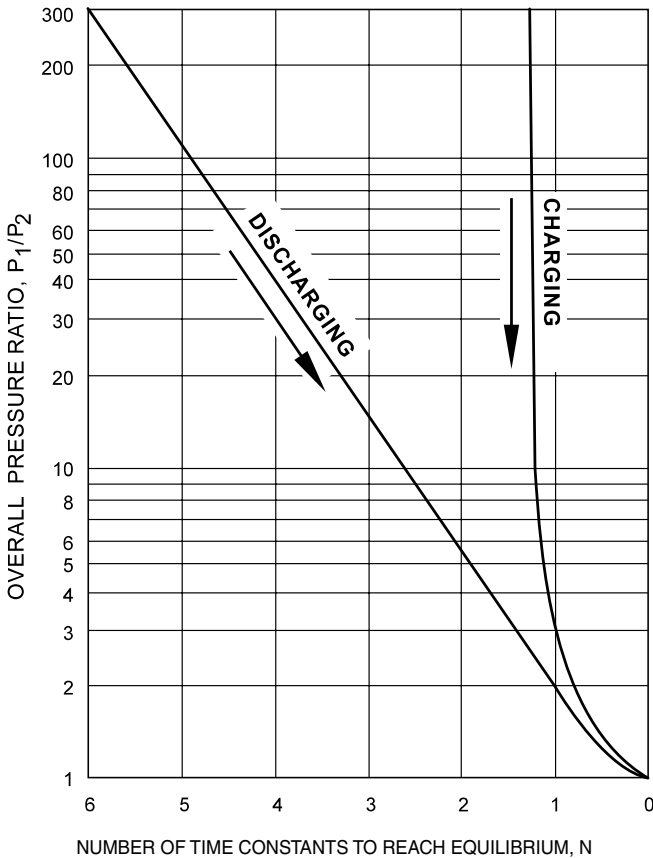

NOMENCLATURE

- K = Units correction factor
- L = Flow resistance, (Lohms)
- N_i = Initial number of system time constants
- N_f = Final number of system time constants
- P_1 = Upstream gas pressure
- P_2 = Downstream gas pressure
- f_T = Temperature factor
- t = Time to charge up or blow down a pressure vessel (sec.)
- V = Pressure vessel volume
- τ = System time constant (sec.)

RESISTANCE TO FLOW IN TUBING

The Lohm Laws, described in the preceding pages, accurately relate flow, pressure drop, and Lohm rating for individual components. For tubing, however, these variables are best related in graph form. The following graphs show pressure drop and flow rate for four different standard sizes of tubing offered by The Lee Company. A 10 cm length of tubing is used in the graphs. If your flow problem involves longer tubing length, increase the pressure drop proportionately.

Example:

To find the pressure drop for a 30 cm length of Lee Company standard 0.032" I.D. tubing flowing 100 mL/min. of water, begin by consulting the water flow graph. From the graph, you determine that the pressure drop is 4 psia for a 100 mL/min. flow rate. Adjust this to your length of 30 cm by ratio:

$$\frac{30 \text{ cm}}{10 \text{ cm}} \times 4 \text{ psid} = 12 \text{ psid}$$

Due to slight variations that normally occur in the tubing I.D., these flow calculations for tubing are not exact, but are useful for most design work.

TUBING FLOW CURVES - WATER FLOW

For 10 cm Tube Length

EFFECTS OF TUBE DIAMETER

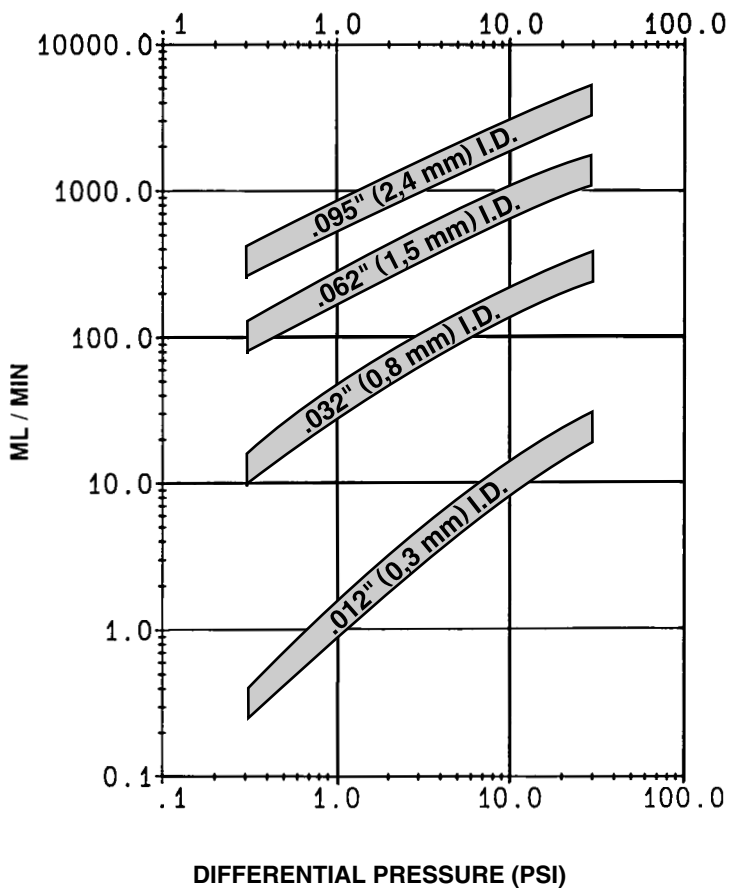

TUBING FLOW CURVES - AIR FLOW For 10 cm Tube Length

EFFECTS OF TUBE DIAMETER

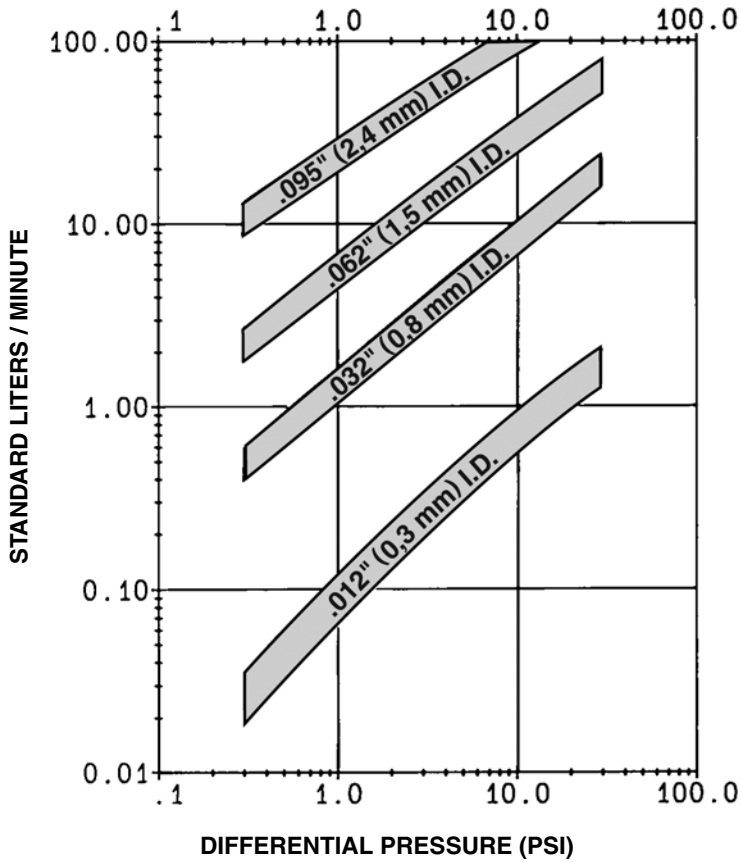

TUBING VOLUME vs. LENGTH

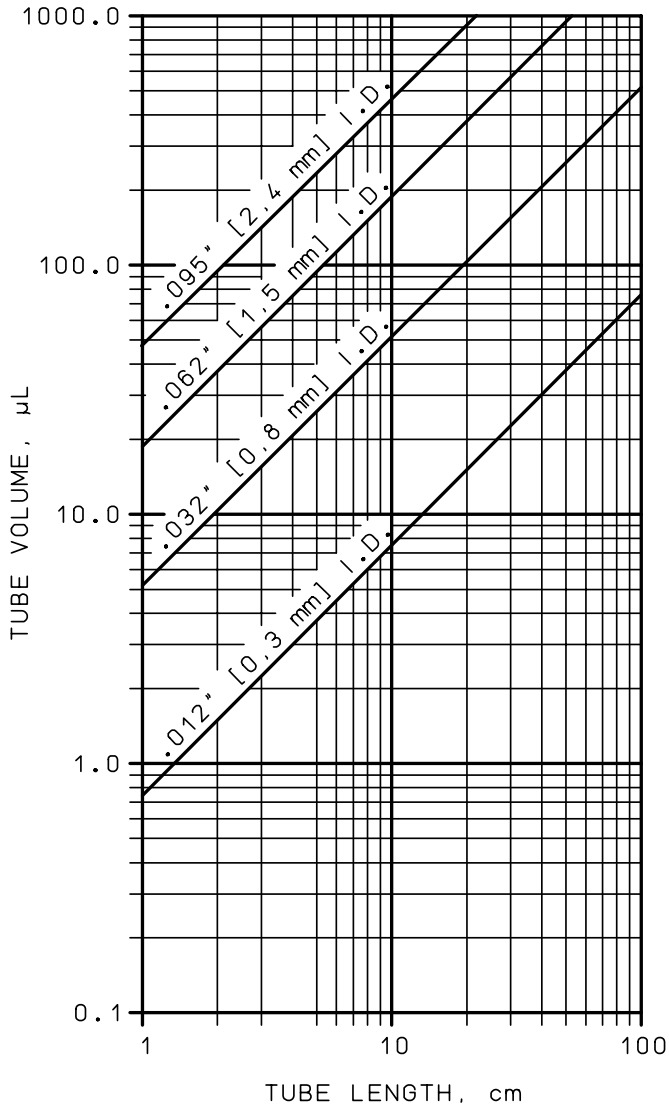

CONTAMINATION – Fluidic System Cleanliness

S

The number one cause of hydraulic and fluidic system failure is contamination. Every fluidic system is sensitive to this. The degree of sensitivity is usually determined by the smallest passage in the system. This may be an orifice, a valve seat or clearance between two components.

Contaminants enter the system in one of several ways:

- Dirty or contaminated fluid
- Debris introduced when the system is “opened” (i.e. maintenance, tubing changes, fluid replenishment etc.)
- Debris “built into” the system

The simplest problem is the fluid. This must be filtered to the proper micron level. Any new fluid added to the system must also be properly filtered.

Introduction of contamination during maintenance is a design issue. Any point in the system that needs to be opened should have a safety screen downstream, prior to sensitive components.

The third scenario, building in contamination is usually an assembly and housekeeping issue. All components, including filters, contain debris. These are from the manufacturing process, packaging, shipping, storage and even handling prior to final assembly. Sintered filters may have small loose particles while machined manifolds may contain loose metal shavings or burrs. All components should be flushed prior to assembly. This removes loose particles and prevents them from entering the fluidic system. In critical systems it may be necessary to flush the system as it is assembled, starting from the reservoir moving out to the final dispense tip.

OHM'S LAW

Electrical energy is governed by several basic laws. The first, Ohm's law, is similar to the Lohm law and defines the resistance of a device to the flow of electrons.

$$V = I \times R$$

V = electric potential (volts)
 I = current (amperes)
 R = resistance (ohms)

When current passes through a resistance, power is dissipated in the form of heat, as in an oven. Power is calculated by the following:

$$P = V \times I$$

P = power (watts)

These equations allow any one of the four electrical parameters to be expressed in terms of any other two. A reference table of derived expressions is given below.

DC ELECTRICAL EQUATIONS			
VOLTAGE	CURRENT	RESISTANCE	POWER
$I \times R$	$\frac{V}{R}$	$\frac{V}{I}$	$V \times I$
$\frac{P}{I}$	$\frac{P}{V}$	$\frac{V^2}{P}$	$\frac{V^2}{R}$
$\sqrt{(P \times R)}$	$\sqrt{\left(\frac{P}{R}\right)}$	$\frac{P}{I^2}$	$I^2 R$

ELECTRICAL ENGINEERING DATA

In a DC solenoid valve there is a magnetic coil that actuates the valve mechanism. The coil can be electrically modeled as an inductance and a resistance in series. The typical room temperature coil resistance and operating voltage determine the steady state current and power consumption, as shown in the table below.

Lee Solenoid Coil Electrical Characteristics

VALVE TYPE	DESIGN PARAMETERS					TIME CONSTANT (Sec) (Ω)
	RATED VOLTAGE (vdc)	POWER (mWatt)		RESISTANCE (ohms)	INDUCTANCE (mHenrys)	
		@ RATED VOLTAGE	MAX. CONTINUOUS			
LFA	24	280	780	2080	2600	.00125
	12	280	780	500	660	.00132
	5	280	780	85	90	.00110
	24	490	780	1180	1200	.00101
	12	490	780	295	310	.00105
	5	490	780	51	50	.00098
	24	780	780	738	900	.00123
	12	780	780	185	220	.00119
	5	780	780	32	30	.00094
LHD	24	550	850	1042	665	.00064
	12	550	850	262	155	.00059
	5	550	850	46	30	.00065
	24	750	850	766	460	.00060
	12	750	850	193	130	.00067
	5	750	850	33	20	.00061
	24	850	850	675	340	.00050
	12	850	850	170	70	.00041
	5	850	850	30	12	.00040
LFY	24	1000	1000	576	—	—
	12	1000	1000	144	—	—
	24	1500	1500	384	—	—
	12	1500	1500	96	—	—
LFR	24	1600	1600	353	1080	N/A
	12	1600	1600	90	280	N/A

LEE SOLENOID VALVE DRIVE CIRCUIT SCHEMATICS

The coil inductance and the resistance affect the valve's response time by opposing changes in the coil current. The time constant shown in the preceding table is the time required for the current in a valve coil to reach 63% of its steady state value, when subjected to a step voltage input. When the solenoid valve is turned off, the energy stored in the coil's magnetic field will be dissipated by some means, usually through a diode to keep the circuit operation within predictable, safe limits. Several proven circuit designs to optimize response time or power consumption are presented on the following pages. These designs are 'typical' circuits and components listed are typical for Lee solenoid valves. For additional circuits (for specific valves or pumps), contact The Lee Company for assistance.

Basic Transistor Driver Schematic (Lee Drawing LFIX1001850A)

All Lee solenoid valves can be operated with a variety of circuits, the simplest being a transistor and diode with varying additional complexity depending upon the performance demands of the application.

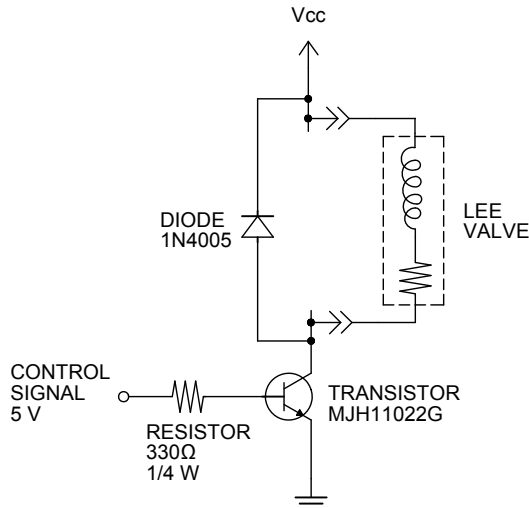

Note: Vcc = Required Lee Co Solenoid Valve Operating Voltage

S

Spike and Hold Driver Schematic (Lee Drawing LFIX1001750A)

This circuit can be used as either an enhanced response time driver or as a low power consumption driver. As an enhanced response time driver, select V1 (usually 2-4 times the rated voltage of the valve being driven) as required to obtain the desired valve response. V2 is the nominal rated valve voltage. Choose values for R1 and C1 to determine V1 pulse duration.

As a low power consumption driver, V1 is the rated valve voltage and V2 is one half the value of V1. This serves to provide full actuation voltage to the valve, which reduces the applied voltage by 50%, thus reducing the valve's power consumption by 75%.

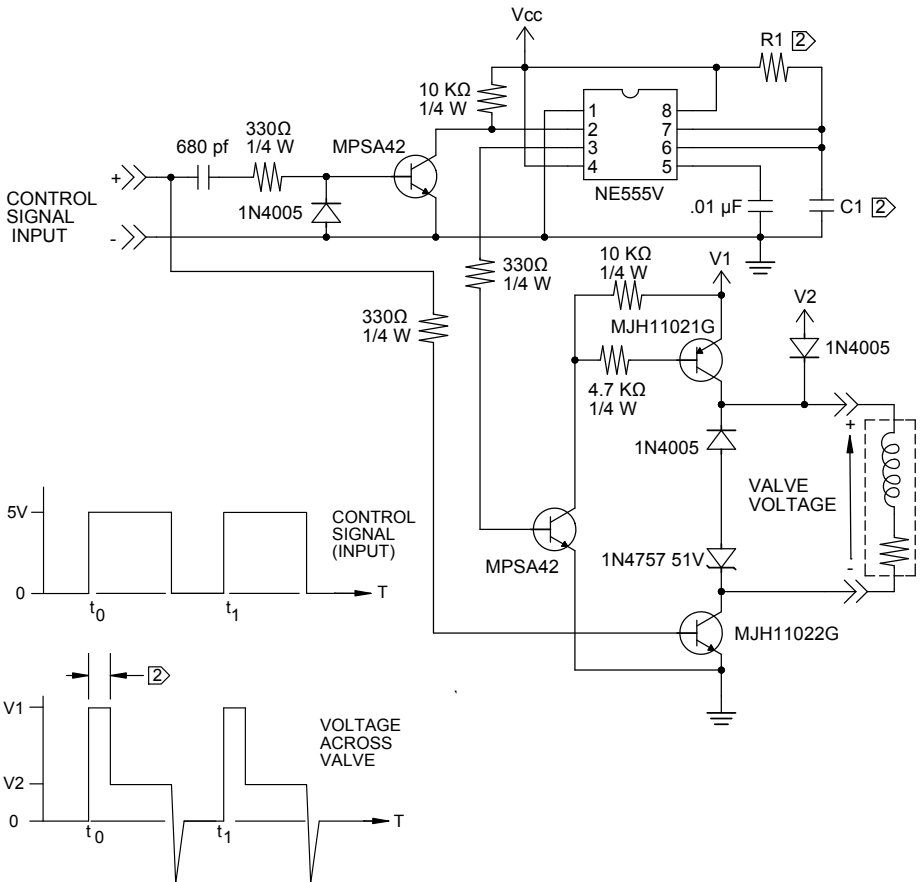

Notes:

1. Do not exceed the valve's maximum power rating.
2. $V1$ Pulse Duration = $1.1 \times R1 \times C1$. Adjust values as required to obtain desired pulse duration. For $C1 = 0.047 \mu\text{F}$, $R1 = 100\text{k}$ pot, spike time range is 0.05 – 5.0 ms.
3. V_{cc} range recommended = 4.5 V to 16 V
4. $V1$ = Required valve spike voltage. $V2$ = Required valve nominal hold voltage.

Fast Response Driver Schematic (Lee Drawing LFIX1001800A)

The response time of most Lee solenoid valves can be reduced by operating the valve at a higher than normal supply voltage in conjunction with a properly selected zener diode. When used in this manner, care must be taken that the power rating of the valve is not exceeded. Excessive heat may cause damage. Calculate the power ($P = V^2/R$) and multiply this by the percent on time in the duty cycle. The result is the mean power dissipation, which should be less than the valve's maximum power rating.

Shown below is a typical circuit designed to enhance the response time of a Lee solenoid valve.

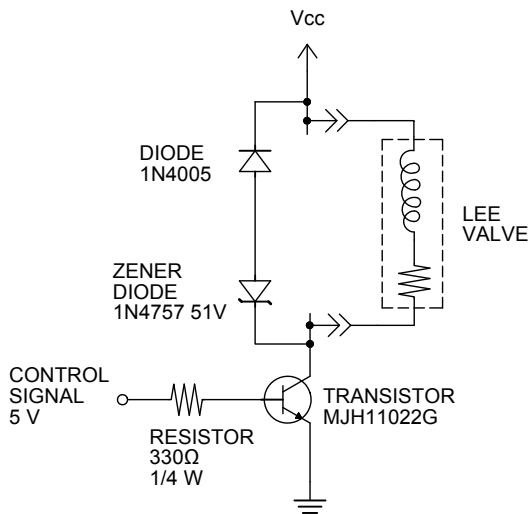

Note: Vcc = Required Lee Co Solenoid Valve Operating Voltage

Low Power Consumption Driver Schematic (Lee Drawing LFIX1000650A)

S

This circuit provides a 70% reduction in valve power consumption. The valve is actuated with the full design voltage and then held at a holding voltage of approximately one half of the design voltage. The additional voltage required to actuate the valve is stored in the capacitor C2. When the control voltage signals the valve on, the transistors are switched such that C2 doubles the supply voltage and discharges through the valve coil. Recommended values for various valves are given in the table on the following page. Resistor R3 determines the peak current and rate of recharge and should be sized according to the particular application.

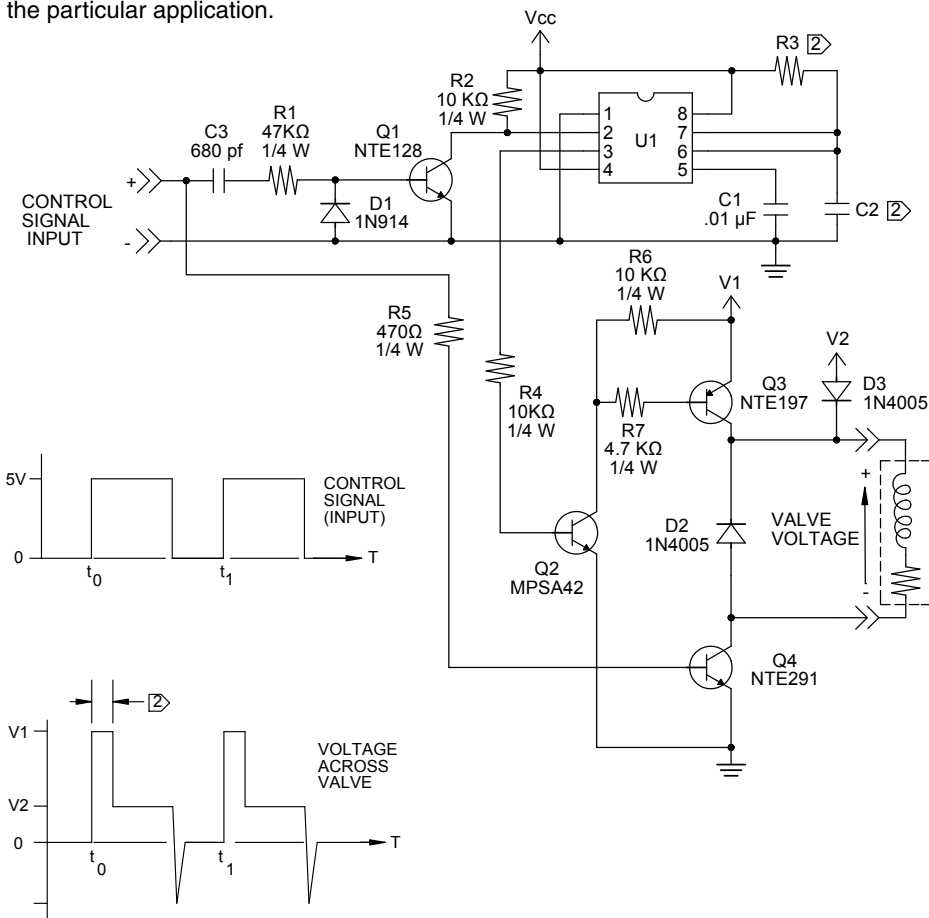

Notes: 1. Do not exceed the valve's maximum power rating.

2. V1 Pulse Duration = $1.1 \times R3 \times C2$. Adjust values as required to obtain desired pulse duration, spike time range varies between 2.6 – 26 ms depending on valve design and R3 value chosen.

3. Vcc range recommended = 4.5 V to 16 V

4. V1 = Required valve input voltage. V2 = Required valve hold voltage.

Low Power Drive Circuit Resistor (R3) Selection

VALVE TYPE	V1 ACTUATION VOLTAGE (COIL DESIGN)	COIL DESIGN POWER (mW)	V2 HOLD VOLTAGE	HOLD POWER (mW)	C2 CAPACITOR (μF)	R3 RESISTOR (KΩ)
LHD	5	550	3	198	0.047	56
	12	550	6	137	0.047	51
	24	550	12	138	0.047	62
	5	750	3	273	0.047	75
	12	750	6	187	0.047	56
	24	750	12	188	0.047	56
LFA	5	280	3	105	0.047	120
	12	280	6	72	0.047	330
	24	280	12	69	0.047	100
	5	490	3	176	0.047	91
	12	490	6	217	0.047	120
	24	490	12	122	0.047	120
	5	780	3	281	0.047	91
	12	780	6	195	0.047	510
	24	780	12	195	0.047	110

Latching Valve Driver Schematic (H-Bridge Design)

The Lee Company's LHL Series latching valves are designed to operate on 10 ms (min), bi-directional pulses. When integrating these latching valves into a system, only a single driving supply is needed. An H-Bridge circuit can be used to switch current direction (an additional logic supply may also be needed depending on the individual application). Most H-Bridge drivers such as Freescale's 17529 or 33886 would be suitable for the task, depending on how many valves are to be driven, the valve's specified voltage, PCB space constraints, etc. Regardless of the H-Bridge used, the following tips should lead to success when designing an electrical circuit to drive such a valve.

1. Connect the logic supply and driving supply. These are normally separate power supplies (one to drive the logic circuitry in the application, such as microprocessors, and another to drive the valves themselves), though they can be the same supply under certain circumstances.
2. Connect any enable/disable inputs of the H-Bridge to the appropriate logic. If the H-Bridge is to remain on, connect the enable/disable input(s) to HIGH or LOW (depending on which level asserts the input).
3. Ensure that any charge pump capacitors are attached. Refer to the H-Bridge manufacturer's data sheet and use the recommended values.
4. Design adequate power supply decoupling. This can often be achieved by connecting capacitors across the supply terminals. The H-Bridge manufacturer's data sheet may have device-specific tips.
5. Design the logic which will control the H-Bridge. This can be done easily with a microprocessor or with combinational logic. The basic logic is described below:
 - a. To switch the valve for Common to Port-A flow...
 - i. Enable the H-Bridge if it is not already enabled. Refer to the H-Bridge's data sheet to determine whether or not the disable-enable delay is short enough to enable/disable on the fly.
 - ii. Drive the H-Bridge in its forward operation mode. The exact logic to do this will be in the H-Bridge manufacturer's data sheet, though it typically involves setting one input HIGH and another LOW. This will apply current in the forward direction through the valve.
 - iii. Wait 10 ms (min). This will allow the valve to shuttle and become magnetically latched.
 - iv. Stop current to the valve. This can be done by either disabling the H-Bridge (in which case the enable-disable delay of the device should be investigated) or by setting both H-Bridge inputs to either HIGH or LOW.
 - b. To switch the valve for Common to Port-B flow...
 - i. Enable the H-Bridge if it is not already enabled. Refer to the H-Bridge's data sheet to determine whether or not the disable-enable delay is short enough to enable/disable on the fly.

Latching Valve Driver Schematic (H-Bridge Design), cont.

- ii. Drive the H-Bridge in its reverse operation mode. The exact logic to do this will be in the H-Bridge manufacturer's data sheet, though it typically involves setting one input HIGH and another LOW. This will apply current in the reverse direction through the valve.
- iii. Wait 10 ms (min). This will overcome the magnetic latching force and allow the valve to shuttle in the other direction.
- iv. Stop current to the valve. This can be done by either disabling the H-bridge (in which case the enable-disable delay of the device should be investigated) or by setting both H-Bridge inputs to either HIGH or LOW.

An example utilizing Freescale's 17529 as an H-Bridge drive with two LHLA0521111H valves is shown below. This sample implements two, 5 volt valves, cycling at 10 Hz. The valves are cycled at different times to reduce peak power supply current. Refer to the waveform in the graph on the following page.

Dual, 5vdc, Latching Valve Driver Schematic (Lee Drawing LFIX1001900A)

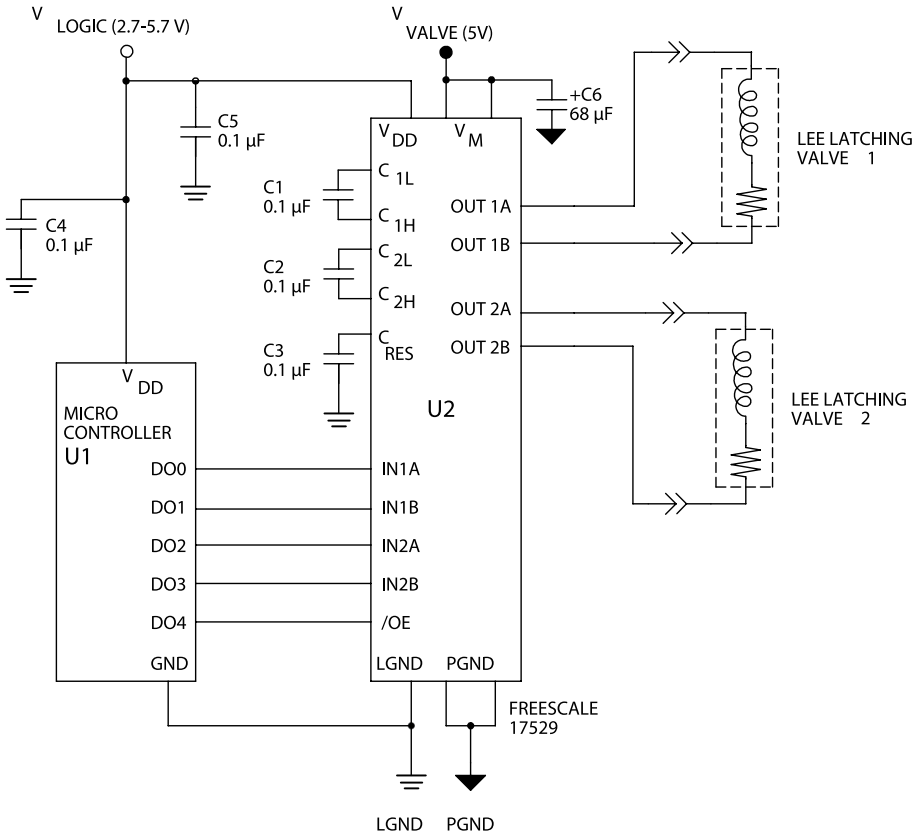

Waveform Graph

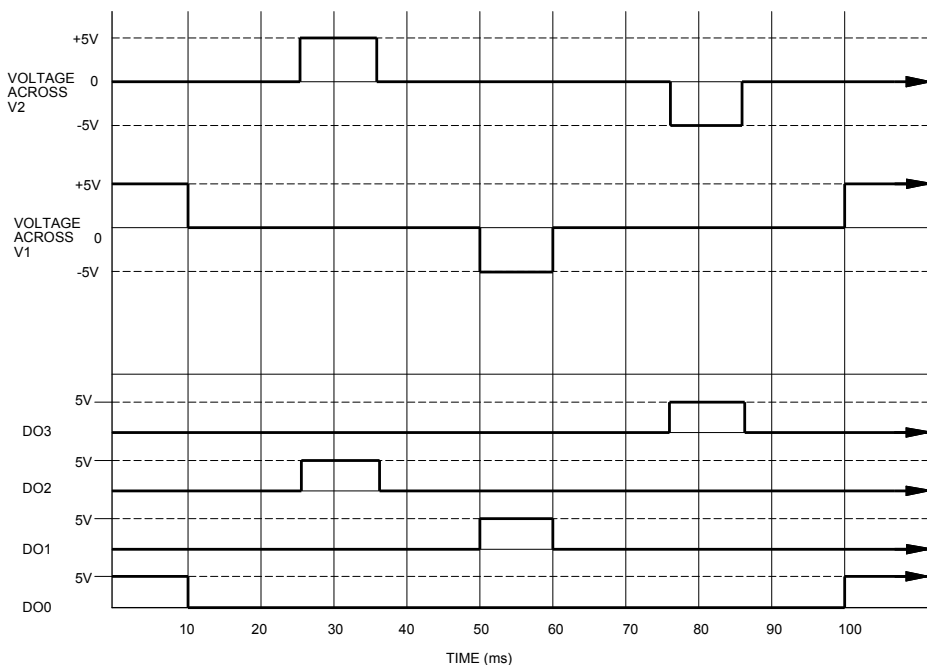

Quad, 5vdc, Latching Valve Driver Schematic (Lee Drawing LFIX1001950A)

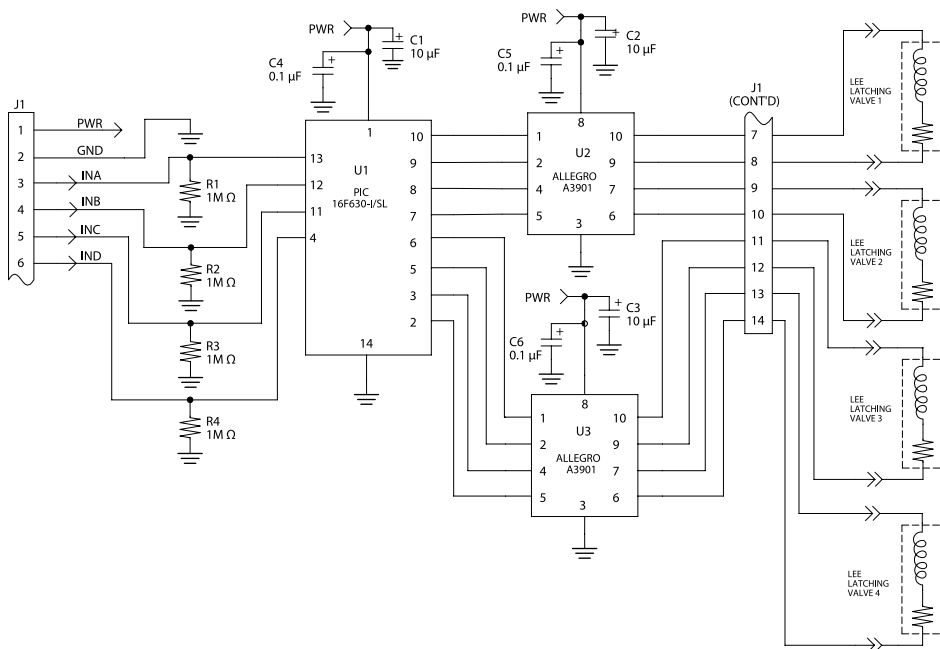

PRIMARY STANDARDS*

- Meter* Length equal to 1,650,763.73 wavelengths in vacuum of the radiation corresponding to the transition between the levels $2p_{10}$ and $5d_5$ of the Krypton-86 atom.
- Kilogram* Mass equal to the mass of the international prototype of the kilogram. This is a particular cylinder of platinum-iridium alloy which is preserved in a vault at Sèvres, France by the International Bureau of Weights and Measures.
- Second* Time duration of 9,192,631,770 periods of the radiation corresponding to the transition between the two hyperfine levels of the ground state of the cesium-133 atom.

DERIVED STANDARD

- Newton* Force which gives to a mass of 1 kilogram an acceleration of 1 meter per second per second.

EXACT CONVERSIONS*

1 pascal	= 1 newton/meter ²
1 atmosphere	= 101,325 pascals
1 bar	= 100,000 pascals
1 centipoise	= 0.001 newton-second/meter ²
1 centistoke	= 1×10^{-6} meter ² /second
1 fluid ounce (U.S.)	= $2.95735295625 \times 10^{-5}$ meter ³
1 foot	= 0.3048 meter
1 gallon (U.S.)	= $3.785411784 \times 10^{-3}$ meter ³
1 gram	= 0.001 kilogram
1 inch	= 0.0254 meter
1 kilogram force	= 9.80665 newtons
1 liter	= 0.001 meter ³
1 micron	= 1×10^{-6} meter
1 milliliter	= 1×10^{-6} meter ³
1 ounce mass (avdp)	= 0.028349523125 kilogram
1 pound force (avdp)	= 4.4482216152605 newtons
1 pound mass (avdp)	= 0.45359237 kilogram

*Exact by National Institute of Standards and Technology

DERIVED CONVERSIONS:

1 foot of H ₂ O at 4°C	=	2,988.98 pascals
1 gram/centimeter ³	=	1,000 kilograms/meter ³
1 inch of H ₂ O at 4°C	=	249.082 pascals
1 inch of Hg at 0°C	=	3,386.389 pascals
1 pound _F / inch ²	=	6,894.7572 pascals
1 pound _M / inch ³	=	27,679.905 kilograms/meter ³
1 quart (U.S.)	=	9.4635295 x 10 ⁴ meter ³
1 drop	=	50 microliters
1 bar	=	14.503774 pound _F / inch ²

CONVERSION FACTORS:

MASS

↓ To Convert ↓	→ Into →	LB _M (avdp)	OZ _M (avdp)	SLUG	gram	kg _m
LB_M (avdp)	—	16.00	3.108 x 10 ⁻²	453.6	0.4536	
OZ_M (avdp)	6.250 x 10 ⁻²	—	1.943 x 10 ⁻³	28.35	2.835 x 10 ⁻²	
SLUG	32.17	514.8	—	1.459 x 10 ⁴	14.59	
gram	32.17	514.8	6.852 x 10 ⁻⁵	—	14.59	
kg_m	2.205	35.27	6.852 x 10 ⁻²	1,000	—	

Multiply by —

CONVERSION FACTORS

VOLUME

Into → ↓ To Convert	FT. ³	IN. ³	GAL. (U.S.)	QUART (U.S.)	FL. OZ. (U.S.)	liter	mL	m ³
FT. ³	—	1,728	7.481	29.92	957.5	28.32	2.832 x 10 ⁴	2.832 x 10 ⁻²
IN. ³	5.787 x 10 ⁻⁴	—	4.329 x 10 ⁻³	1.732 x 10 ⁻²	0.5541	1.639 x 10 ⁻²	16.39	1.639 x 10 ⁻⁵
GAL. (U.S.)	0.1337	231.0	—	4.000	128.0	3.785	3,785	3.785 x 10 ⁻³
QUART (U.S.)	3.342 x 10 ⁻²	57.75	0.2500	—	32.00	0.9464	946.4	9.464 x 10 ⁻⁴
FL. OZ. (U.S.)	1.044 x 10 ⁻³	1.805	7.813 x 10 ⁻³	3.125 x 10 ⁻²	—	2.957 x 10 ⁻²	29.57	2.957 x 10 ⁻⁵
liter	3.531 x 10 ⁻²	61.02	0.2642	1.057	33.81	—	1,000	1.000 x 10 ⁻³
mL	3.531 x 10 ⁻⁵	6.102 x 10 ⁻²	2.642 x 10 ⁻⁴	1.057 x 10 ⁻³	3.381 x 10 ⁻²	1.000 x 10 ⁻³	—	1.000 x 10 ⁻⁶
m ³	35.31	6.102 x 10 ⁴	264.2	1,057	3.381 x 10 ⁴	1,000	1.000 x 10 ⁶	—

Multiply by —

CONVERSION FACTORS

S

PRESSURE

Into ↓ To Convert								
	$\frac{\text{LB}}{\text{FT.}^3}$	IN. Hg at 0°C	IN. H ₂ O at 4°C	FT. H ₂ O at 4°C	ATM	$\frac{\text{kg}_F}{\text{cm}^2}$	$\frac{\text{kg}_F}{\text{m}^2}$	kPa
$\frac{\text{LB.}}{\text{IN.}^2}$	—	2.036	27.68	2.307	6.805×10^{-2}	7.031×10^{-2}	703.1	6.895
IN. Hg a 0°C	0.4912	—	13.60	1.133	3.342×10^{-2}	3.453×10^{-2}	345.3	3.386
IN. H ₂ O at 4°C	3.613×10^{-2}	7.355×10^{-2}	—	8.333×10^{-2}	2.458×10^{-3}	2.540×10^{-3}	25.40	0.2491
FT. H ₂ O at 4°C	0.4335	0.4335	0.4335	12.00	—	2.950×10^{-2}	3.048	2.989
ATM	14.70	29.92	406.8	33.90	—	1.033	1.033×10^4	101.3
$\frac{\text{kg}_F}{\text{cm}^2}$	14.22	28.96	393.7	32.81	0.9678	—	1.000×10^4	98.07
$\frac{\text{kg}_F}{\text{m}^2}$	1.422×10^{-3}	2.896×10^{-3}	3.937×10^{-2}	3.281×10^{-3}	9.678×10^{-5}	1.000×10^{-4}	—	9.807×10^{-3}
kPa	0.1450	0.2953	4.015	0.3346	9.869×10^{-3}	1.020×10^{-2}	102.0	—

 Multiply by — 

PRESSURE CONVERSION CHART

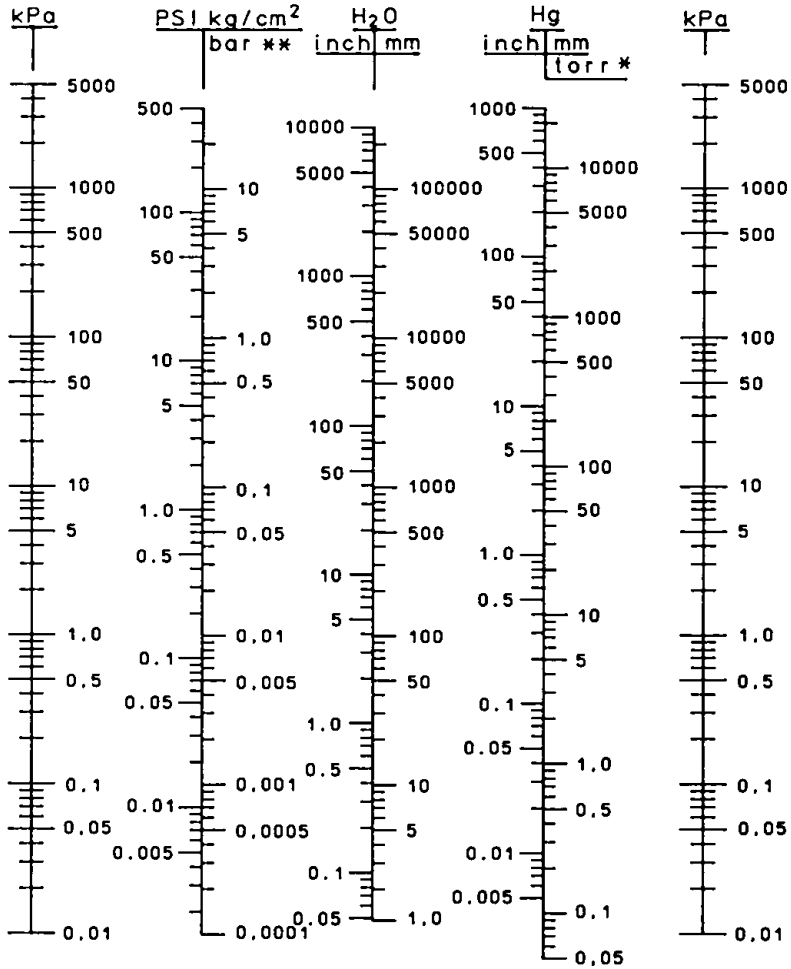

CONVERSION FACTORS – VOLUME TO MASS WATER AT 39.2°F (4°C)

S

MASS

V
O
L
U
M
E

Into ↓ To Convert	LB _M (avdp)	OZ _M (avdp)	SLUG	gram	kg _m
FT. ³	62.43	998.8	1.940	2.832 x 10 ⁴	28.32
IN. ³	3.613 x 10 ⁻²	0.5780	1.123 x 10 ⁻³	16.39	1.639 x 10 ⁻²
GAL. (U.S.)	8.345	133.5	0.2594	3785	3.785
QUART (U.S.)	2.086	33.38	6.484 x 10 ⁻²	946.3	0.9463
FL. OZ. (U.S.)	6.520 x 10 ⁻²	1.043	2.026 x 10 ⁻³	29.57	2.957 x 10 ⁻²
liter	2.205	35.27	6.852 x 10 ⁻²	1,000	1.000
mL	2.205 x 10 ⁻³	3.527 x 10 ⁻²	6.852 x 10 ⁻⁵	1.000	1.000 x 10 ⁻³
m ³	2,205	3.527 x 10 ⁴	68.52	1.000 x 10 ⁶	1,000

Multiply by \rightarrow

NOTE: For application of these factors to fluids with specific gravity other than 1.0, these factors must be multiplied by the actual specific gravity.

EXAMPLE:

Problem: Determine flow rate in lb./hr. of acetone at 40°F and 2 mL/min.

Solution: Specific Gravity S of acetone at 40°F = 0.80

$$\begin{aligned}
 I \frac{\text{lbs}}{\text{hr}} &= \left[I \frac{\text{mL}}{\text{min.}} \right] \left[\frac{\text{conversion}}{\text{factor mL — lbs}} \right] \left[\frac{\text{conversion}}{\text{factor min.— hrs}} \right] [S] \\
 &= \left[2 \frac{\text{mL}}{\text{min.}} \right] \left[2.205 \times 10^{-3} \frac{\text{lbs}}{\text{mL}} \right] \left[\frac{60 \text{ min}}{1 \text{ hr}} \right] [0.80] \\
 &= .21 \frac{\text{lb}}{\text{hr}}
 \end{aligned}$$

CONVERSION FACTORS – MASS TO VOLUME WATER AT 39.2°F (4°C)

MASS

↓ To Convert	→ Into	LB _M (avdp)	OZ _M (avdp)	SLUG	gram	kg _m
V O L U M E	FT. ³	1.602 x 10 ⁻²	1.001 x 10 ⁻³	0.5154	3.532 x 10 ⁻⁵	3.532 x 10 ⁻²
	IN. ³	27.68	1.730	890.6	6.103 x 10 ⁻²	61.03
	GAL. (U.S.)	0.1198	7.489 x 10 ⁻³	3.855	2.642 x 10 ⁻⁴	0.2642
	QUART (U.S.)	0.4793	2.996 x 10 ⁻²	15.42	9.464 x 10 ⁻⁴	0.9464
	FL. OZ. (U.S.)	15.34	0.9586	493.5	3.381 x 10 ⁻²	33.81
	liter	0.4536	2.835 x 10 ⁻²	14.59	1.000 x 10 ⁻³	1.000
	mL	453.6	28.35	1.459 x 10 ⁴	1.000	1,000
	m ³	4.536 x 10 ⁻⁴	2.835 x 10 ⁻⁵	1.459 x 10 ⁻²	1.000 x 10 ⁻⁶	1.000 x 10 ⁻³

Multiply by

NOTE: For application of these factors to fluids with specific gravity other than 1.0, these factors must be divided by the actual specific gravity.

EXAMPLE:

Problem: Determine volume in gallons which would be occupied by 3.0 kg of sea water, specific gravity is 1.02.

Solution:

$$\text{GAL.} = 3.0 \text{ kg} \times \frac{.2642}{1.02} \frac{\text{GAL}}{\text{kg}} = 0.777 \text{ GAL.}$$

VISCOSITY DEFINITIONS

Absolute Viscosity: the force required to move a unit plane surface over another plane surface at unit velocity when surfaces are separated by a layer of fluid of unit thickness.

Unit of Absolute Viscosity in the metric system:

poise and centipoise
 1 poise = 1 gram / (cm) (sec) and
 1 centipoise = 1/100 poise

Unit of Absolute Viscosity in the English system:

slugs / (ft.) (sec.);
 1 slug / (ft.) (sec.) = 1 / 0.002089 poise

Kinematic Viscosity: the absolute viscosity divided by density.

Unit of Kinematic Viscosity in the metric system and commonly used in the countries using the English system:

stoke and centistoke;
 1 stoke = 1 poise / density (gm / mL)
 1 centistoke = 1/100 stoke

Other units of Kinematic Viscosity in the English system, the most practical unit for making calculations is $\text{ft.}^2 / \text{sec.}$; $1 \text{ ft.}^2 / \text{sec.} = 92903 \text{ centistoke}$ and $1 \text{ centistoke} = 1.076 \times 10^{-5} \text{ ft.}^2 / \text{sec.}$

VISCOSITY CONVERSION CHART

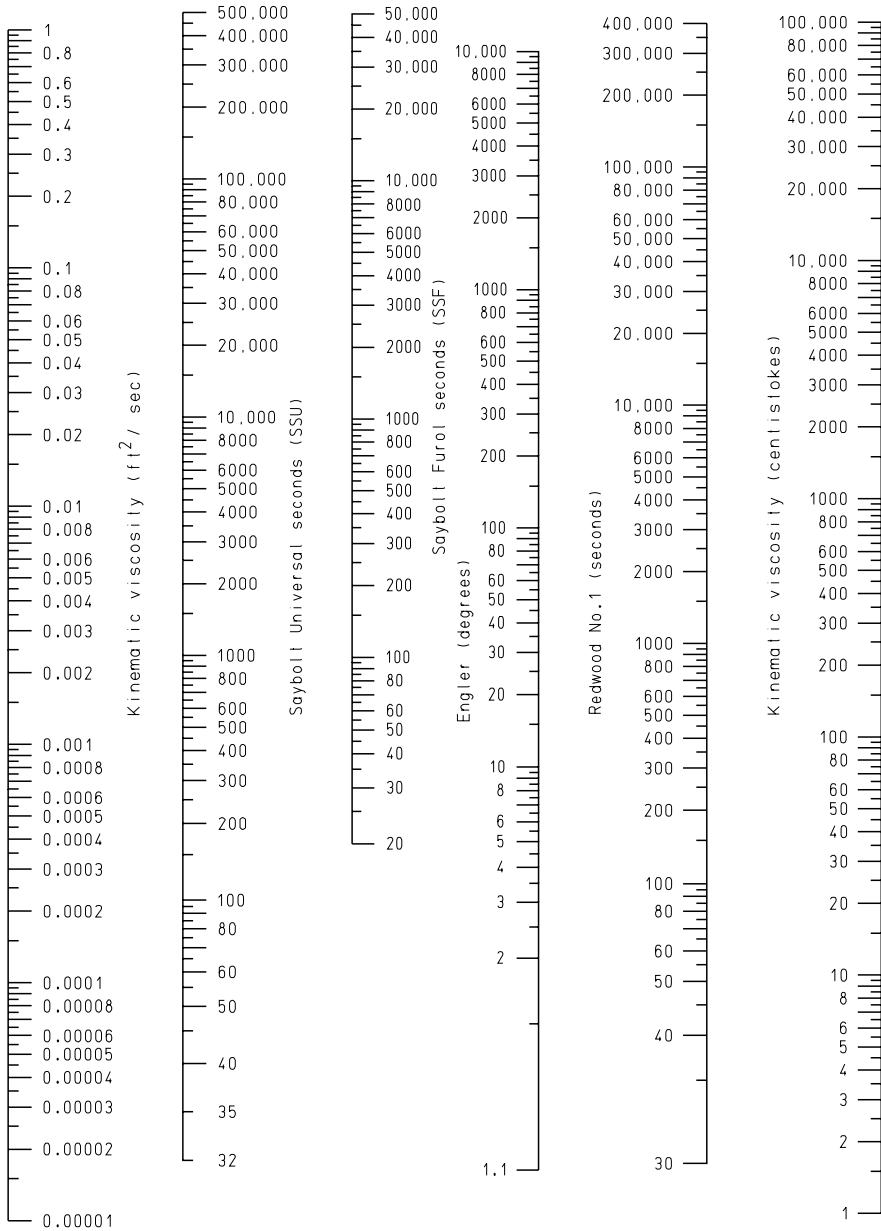

CONNECT HORIZONTALLY

NOTE: Centistokes = $\frac{\text{Centipoise}}{\text{Density}}$

VISCOSITY OF TYPICAL FLUIDS vs. TEMPERATURE

S

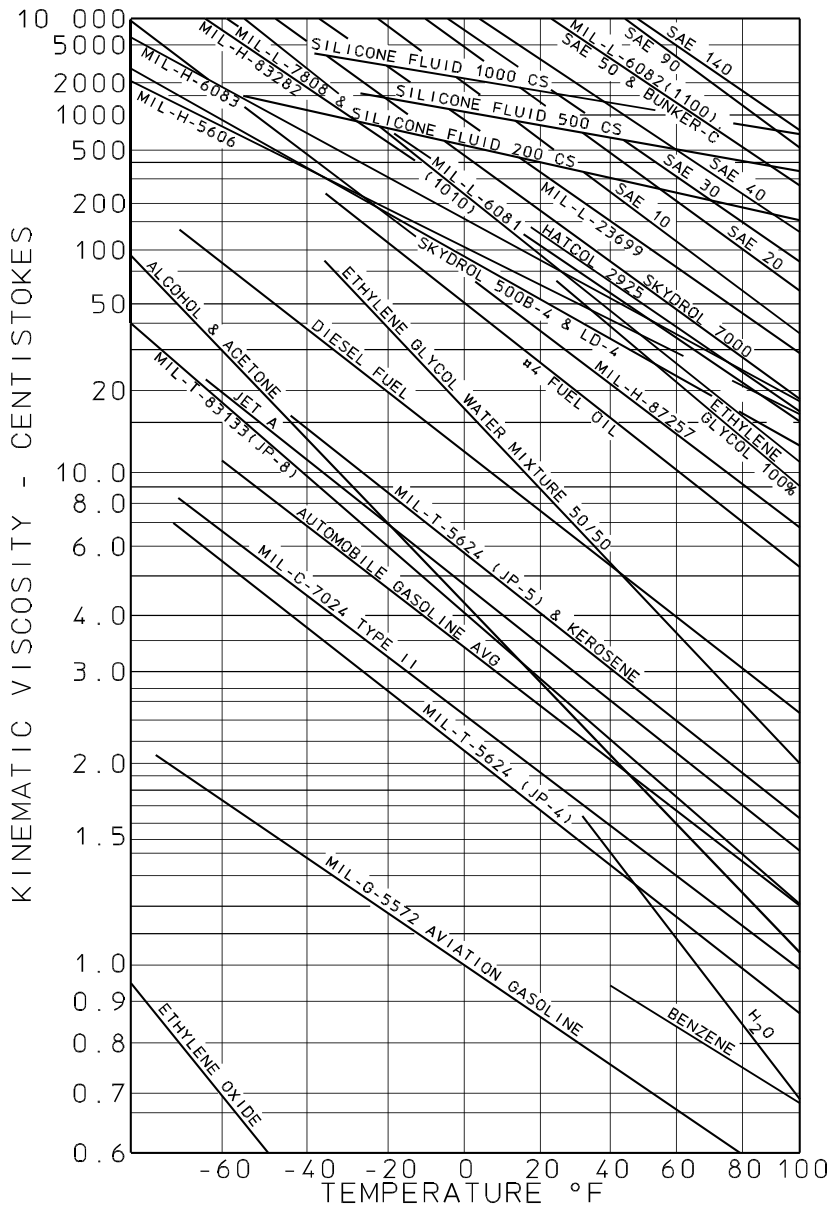



VISCOSITY OF TYPICAL FLUIDS vs. TEMPERATURE

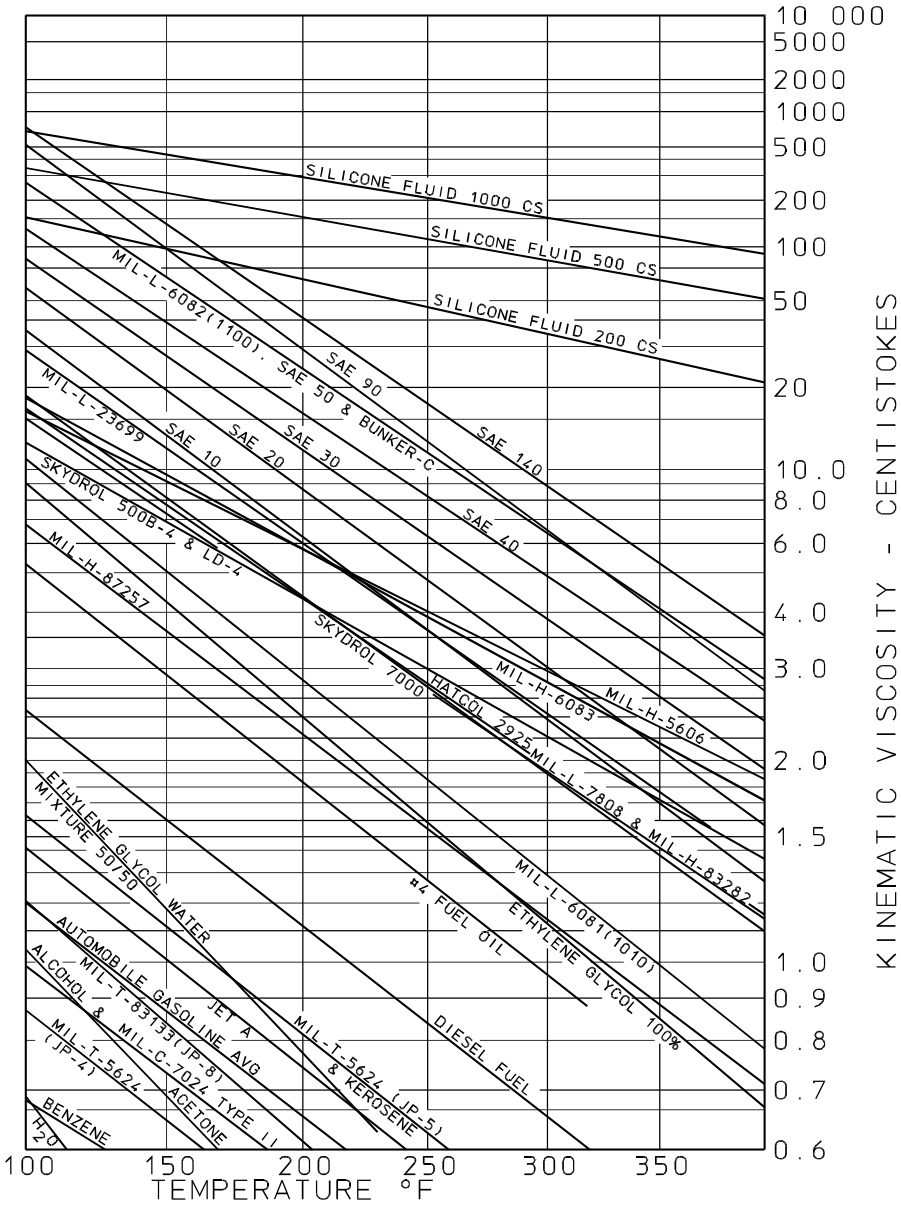

VISCOSITY vs. CONCENTRATION

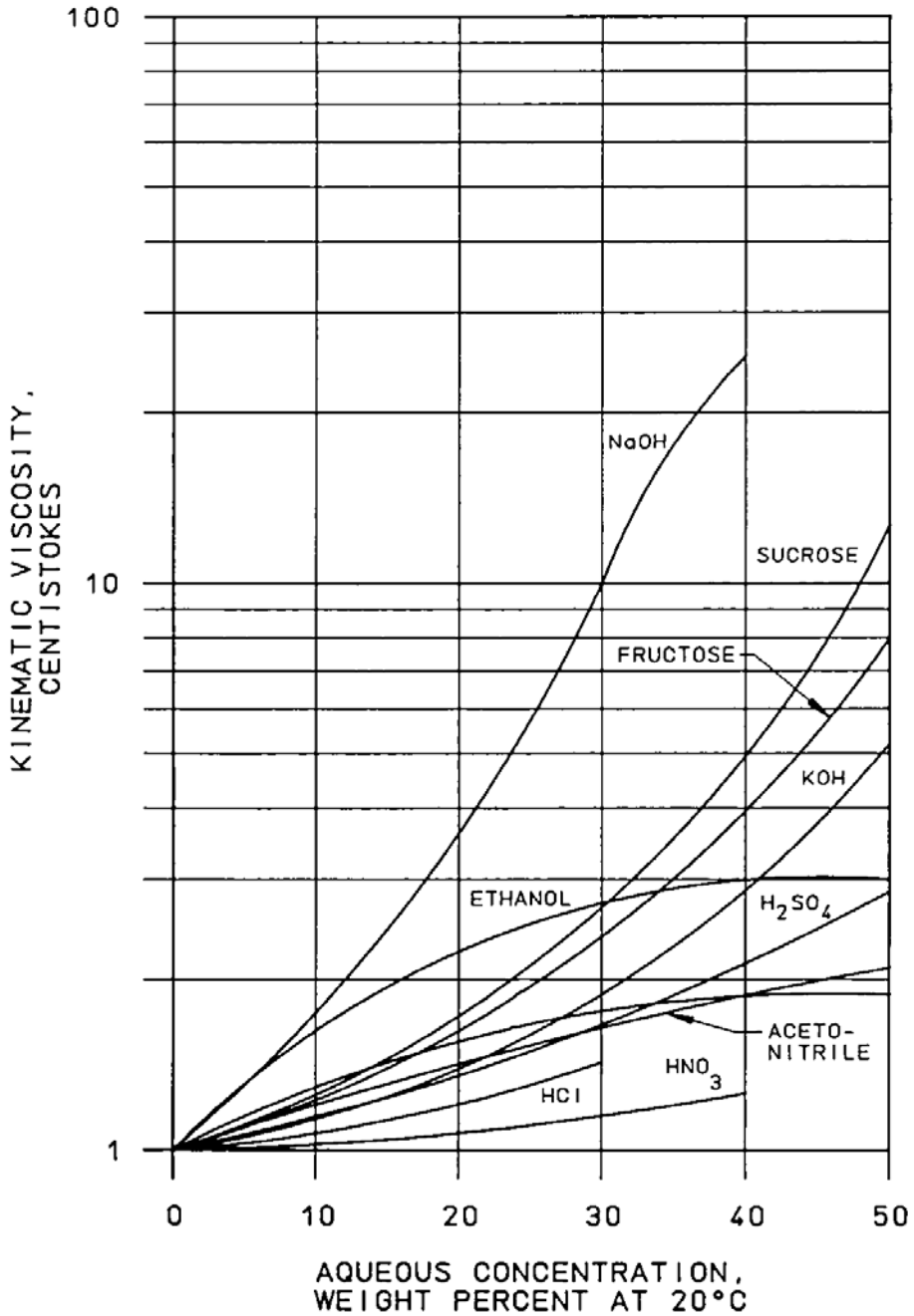

VISCOSITY vs. CONCENTRATION

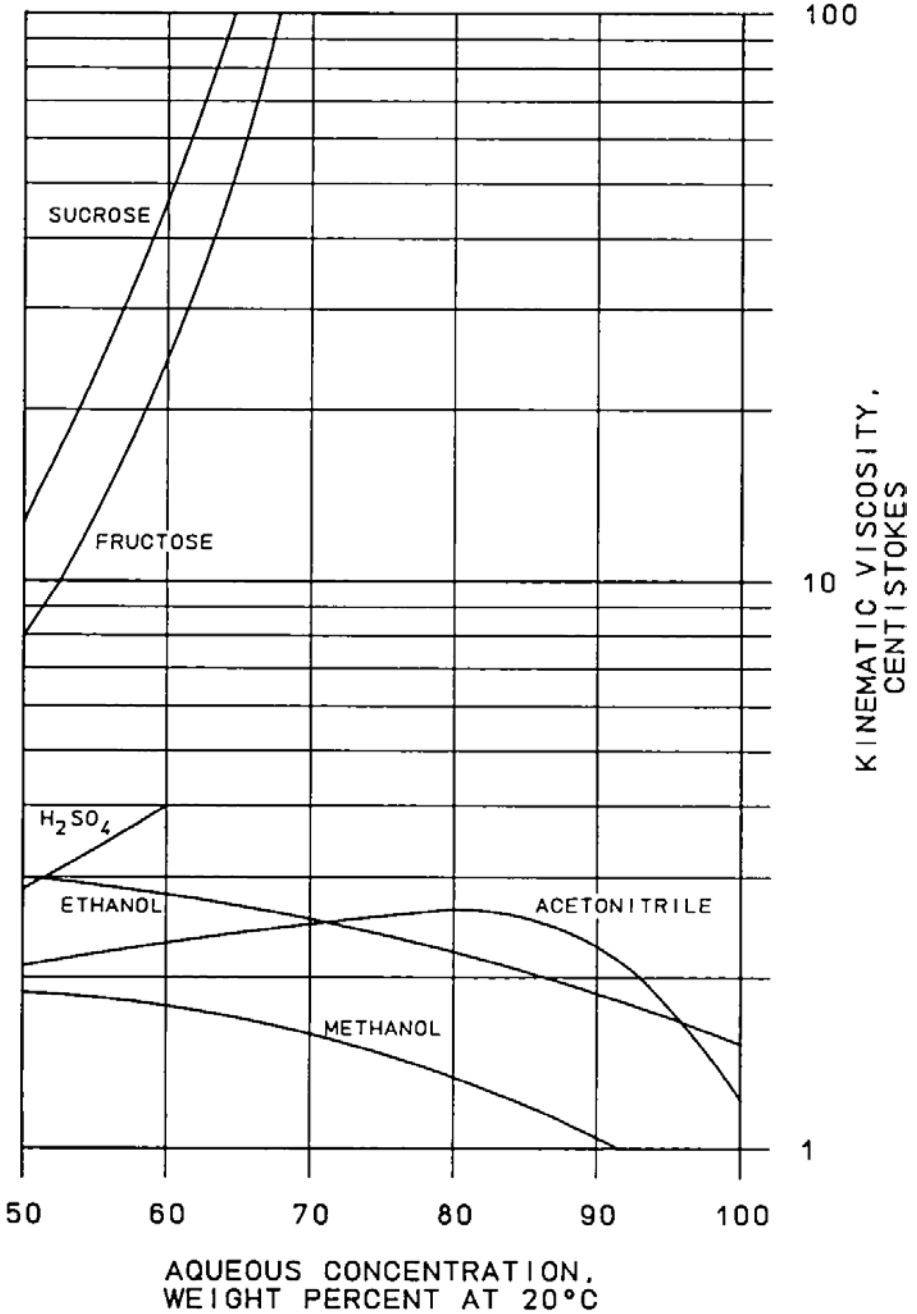

S

SPECIFIC GRAVITY vs. CONCENTRATION

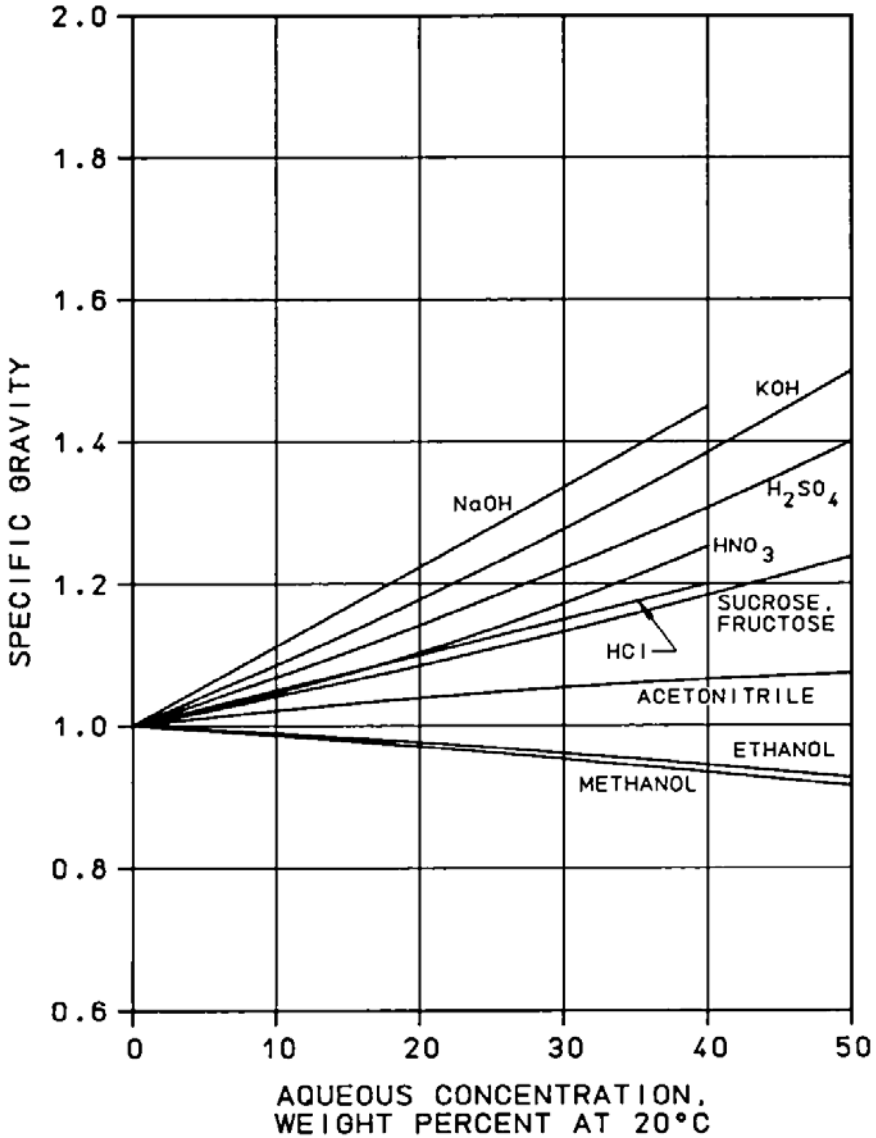

SPECIFIC GRAVITY vs. CONCENTRATION

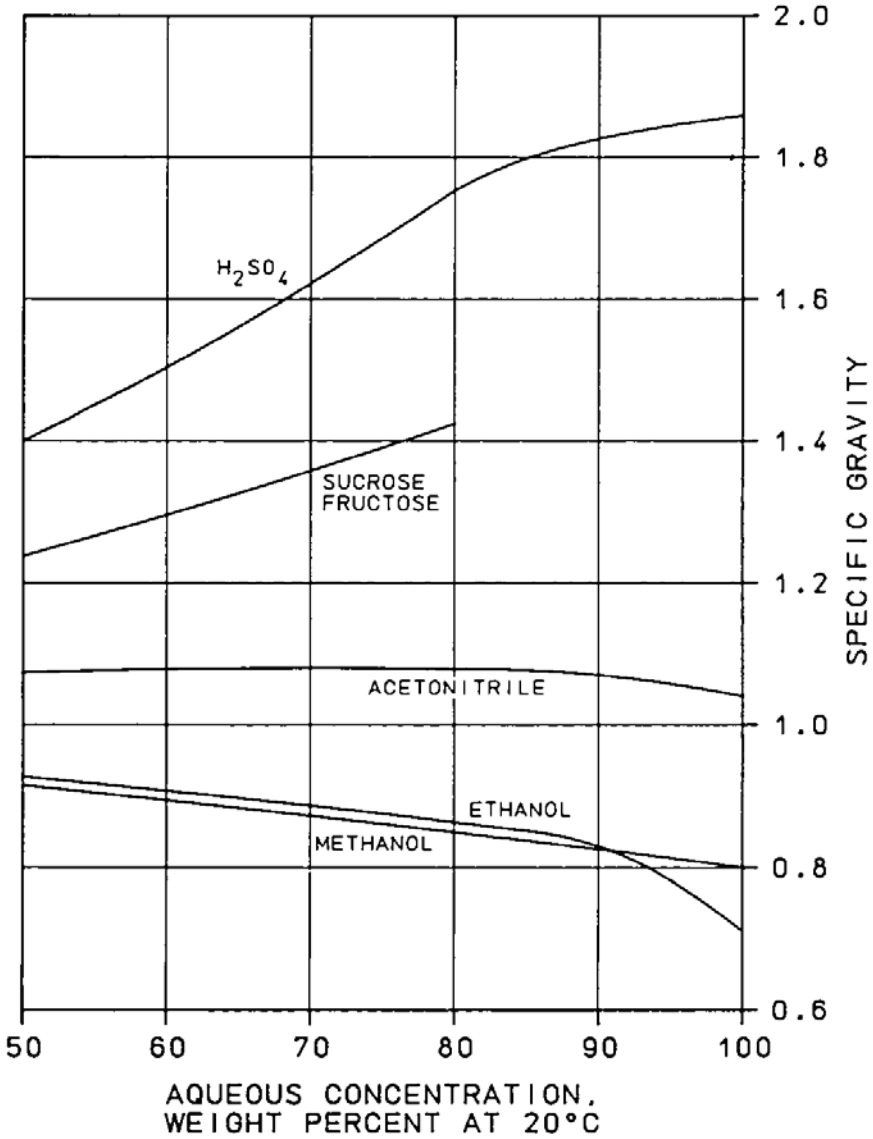

TORQUE CONVERSION CHART

S

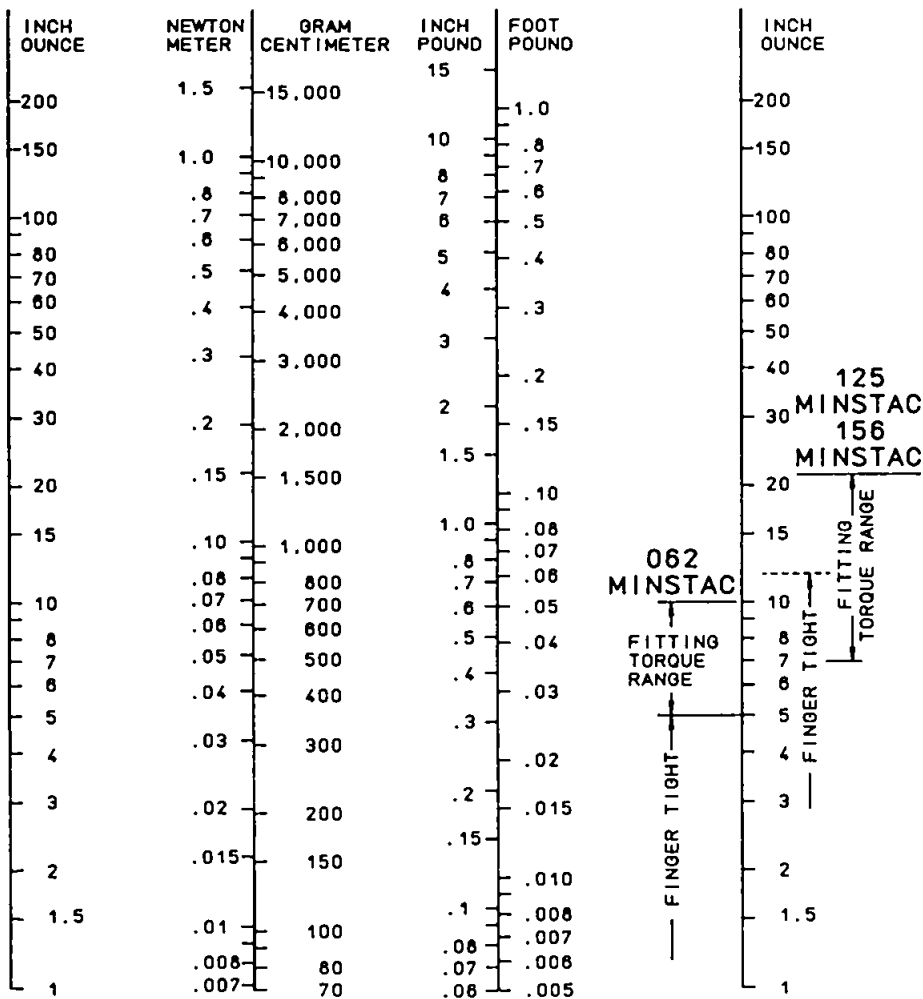

CONNECT HORIZONTALLY

TEMPERATURE CONVERSION

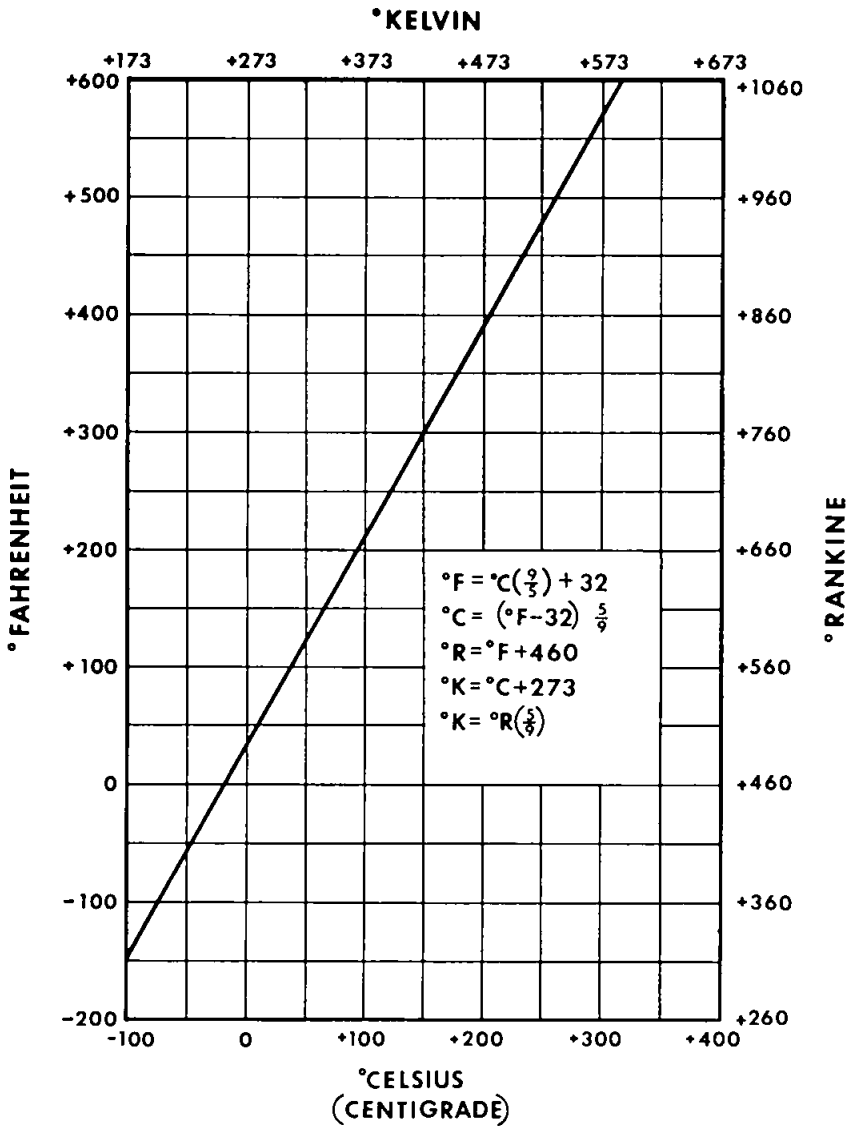

REFERENCE INFORMATION

ENGINEERING REFERENCE

S

MATERIALS – The chemical compatibilities listed are meant as guidelines only. Material samples for immersion testing can be requested from The Lee Company. This is the most accurate method of determining the chemical compatibility of our materials and our customers' specific fluids.

PLASTIC	MECHANICAL STRENGTH	GENERAL CHEMICAL RESISTANCE	THERMAL RESISTANCE	FEATURED PROPERTIES
EVA (Micro-Line™ - TSI) <i>Ethylene-vinyl acetate</i>	3	3	2	Physically conformable
LCP (Vectra® - Celanese) <i>Liquid crystal polymer</i>	5	4	4	Superior balance of all properties
PBT (Valox® - GE) <i>Polybutylene terephthalate</i>	3	3	3	Good balance of all properties
PC (Lexan® - GE) <i>Polycarbonate</i>	3	3	3	Optical clarity
PCTFE (Kel-F® 81 - 3M) <i>Polychlorotrifluoroethylene</i>	3	4	3	Resists most chemicals, zero water absorption
PES (Victrex® - ICI) <i>Polyethersulfone</i>	3	3	4	Dimensionally stable
PEEK (Victrex® - ICI) <i>Polyetheretherketone</i>	4	3	5	Thermal stability & good solvent resistance
PFA (Teflon® - DuPont Dow) <i>Perfluoroalkoxy resin</i>	2	5	2	Chemical & solvent resistant
PMMA (Acrylic) <i>Polymethyl Methacrylate</i>	3	3	3	Transparent, good general properties
PTFE (Teflon® - DuPont Dow) <i>Polytetrafluoroethylene</i>	2	5	2	Unsurpassed chemical resistance
POM (Delrin® - DuPont Dow) <i>Polyoxymethylene</i>	3	3	2	Wear resistance
PPA (Amodel®) <i>Polyphthalamide</i>	3	3	4	Thermal and dimensional stability
PPS (Fortron® - Phillips Petro.) <i>Polyphenylene sulfide</i>	4	3	4	Very good mechanical strength
PVC (<i>Polyvinylchloride</i>)	3	3	3	High flexibility
PVDF (Kynar® - Pennwalt) <i>Polyvinylidene fluoride</i>	3	4	3	Chemical & solvent resistant, porous form
UHMWPE <i>Ultra-high molecular weight polyethylene</i>	3	3	3	Porous form, solvent resistant

KEY: 5..... Superior 4..... Excellent 3..... Good 2 Fair

MATERIALS (continued)

ELASTOMER	WEAR RESISTANCE	GENERAL CHEMICAL RESISTANCE	THERMAL RESISTANCE	FEATURED PROPERTIES
EPDM <i>Ethylene/propylene rubber</i>	3	4	3	Very good solvent resistance
FKM (Viton® Fluoroelastomer - DuPont Dow)	5	4	4	Superior balance of properties
CR (Neoprene® Polychloroprene - DuPont Dow)	3	3	3	Good balance of properties
FFKM (Kalrez® Perfluoroelastomer - DuPont Dow)	3	5	5	Unsurpassed chemical resistance
Silicone (Silastic E® - DuPont Dow)	3	3	4	Good balance of properties

OTHER MATERIALS	MECHANICAL STRENGTH	GENERAL CHEMICAL RESISTANCE	THERMAL RESISTANCE	FEATURED PROPERTIES
TZP (Ceramic)	5	5	5	Superior surface finish and excellent dimensional stability
Sapphire (Aluminum Oxide)	5	5	5	Superior surface finish and excellent dimensional stability

KEY: 5 Superior 4 Excellent 3 Good 2 Fair

ADHESIVES FEATURED PROPERTIES

- Epoxy Good adhesive strength to many materials; good chemical resistance
- Cyanoacrylate..... Quick set; high strength
- Anaerobic Very high strength; very good chemical resistance

METALS FEATURED PROPERTIES

- 316 CRES..... Superior corrosion resistance
- 430 CRES..... Good magnetic properties, good corrosion resistance
- 303,304 CRES..... Good machinability, good corrosion resistance
- 17-4, 17-7 CRES .. High modulus, good corrosion resistance
- FeCr Alloy Excellent corrosion resistance, good magnetic properties
- Aluminum..... Colorability, low cost

Trade names are for reference only.

GENERAL INFORMATION

THE LEE COMPANY

OTHER REGISTERED TRADEMARKS

Throughout this handbook, The Lee Company has referred to suppliers' products by their trade names. A complete list is provided below.

COMPANY	TRADE NAME
Crawford Fitting Company	Swagelok®
CRS Holding, Inc. (Subsidiary of Carpenter Technology Corporation)	Chrome Core 18®
DuPont Dow	Delrin®, Kalrez®, Neoprene®, Silastic E®, Teflon®, Viton®
General Electric Company	Lexan®, Valox®
Green, Tweed and Company	Chemraz®
Hoechst Celanese	Vectra®
Imperial Chemical Industries	Victrex®
Pennwalt Corporation	Kynar®
Phillips Chemical Company	Ryton®
Thermoplastic Scientifics, Inc.	Micro-Line™
The 3M Company	KEL-F®

WARRANTY

The Lee Company is proud to warrant that all items described in this handbook are free from defect in design, workmanship and materials and that they conform to any applicable specifications, drawings, or approved samples.

Our products will only operate as well as the systems in which they are installed. We therefore expect the buyers of our products to be responsible for the proper design and fabrication of the systems in which our products are used. To assist our customers, we maintain a staff of sales engineers that can recommend the proper Lee Company products to satisfy a particular system requirement. However, the buyer assumes the risk of incompatibility between Lee Company products and the fluid media.

Should any Lee Company product not satisfy this warranty, we will promptly repair or replace it within a four (4) year period or the product's published cycle life, whichever is less, without responsibility for indirect or consequential damages, provided the product was used for its intended purpose, and in its intended environment.

Should any Lee product fail to perform to its specifications as stated in this handbook, a Returned Material Authorization, "RMA", number is required prior to returning the product. Please contact The Lee Company for the RMA number. Products returned without an RMA number may not be accepted.