

Servomotori C.C.

D.C. Servomotors



Coppia da 0.2Nm a 8Nm
Torque from 0.2Nm to 8Nm

MP540

Servomotore C.C. - Coppia 0.2Nm D.C. Servomotor - Torque 0.2Nm

CARATTERISTICHE PRINCIPALI

- Servomotori C.C. a norme CEI ed IEC.
- 2 poli - magnete permanente.
- Grado di protezione IP54.
- Isolamento classe F e H.
- Terminali faston.

MAIN FEATURES

- D.C. servomotors according to CEI and IEC standards.
- 2 poles - permanent magnet.
- Degree of protection IP54.
- Insulation F and H class.
- Faston terminals.

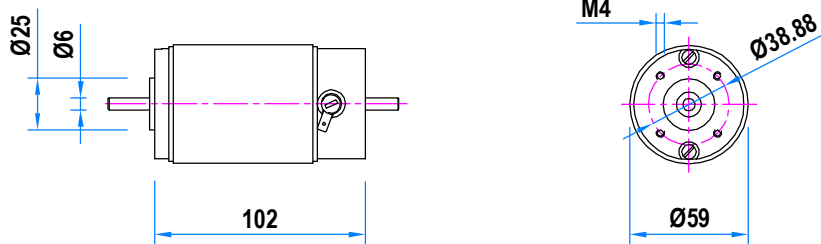

Tipo / Type	L	Coppia a rotore bloccato / Continuous stall torque	Tensione a / Voltage at 1000min ⁻¹
MP540	102	0.2 Nm	8V



OPZIONI :

- Encoder

OPTIONS :

- Encoder

Servomotori C.C. - Coppia da 0.2Nm a 0.45Nm D.C. Servomotors - Torque from 0.2Nm to 0.45Nm

CARATTERISTICHE PRINCIPALI

- Servomotori C.C. a norme CEI ed IEC.
- 2 poli - magnete permanente.
- Grado di protezione IP54.
- Isolamento classe F e H.
- Connettore.

MAIN FEATURES

- D.C. servomotors according to CEI and IEC standards.
- 2 poles - permanent magnet.
- Degree of protection IP54.
- Insulation F and H class.
- Connector.

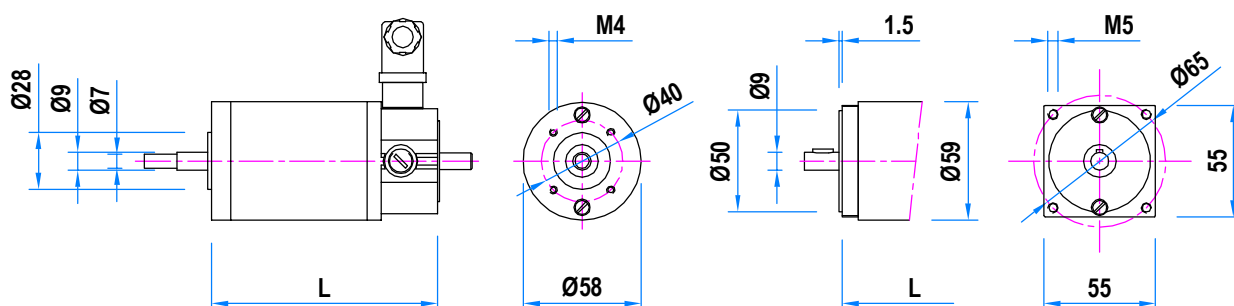

Tipo / Type	L	Coppia a rotore bloccato / Continuous stall torque	Tensione a / Voltage at 1000min ⁻¹
MP44M	112	0.2 Nm	8V - 16V - 24V - 53V
MP44L	132	0.3 Nm	8V - 16V - 24V - 53V
MP44XL	163	0.45 Nm	8V - 16V - 24V - 53V



OPZIONI :

- Flange e alberi speciali
- Freno di sicurezza esterno
- Dinamo tachimetrica
- Encoder
- Cavo o terminali faston

OPTIONS :

- Special shafts and flanges
- External safety brake
- Tachogenerator
- Encoder
- Cable or faston terminals

MP66

Servomotori C.C. - Coppia da 0.7Nm a 2.1Nm

D.C. Servomotor - Torque from 0.7Nm to 2.1Nm

CARATTERISTICHE PRINCIPALI

- Servomotori C.C. a norme CEI ed IEC.
- 2 poli - magnete permanente.
- Grado di protezione IP54.
- Isolamento classe F e H.
- Connettore.

MAIN FEATURES

- D.C. servomotors according to CEI and IEC standards.
- 2 poles - permanent magnet.
- Degree of protection IP54.
- Insulation F and H class.
- Connector.

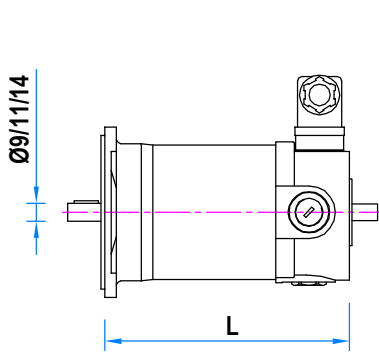

IEC 56 B5 Ø120
IEC 63 B5 105x105
IEC 71 B5 120x120

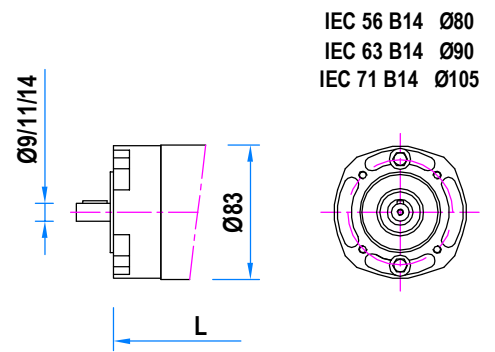
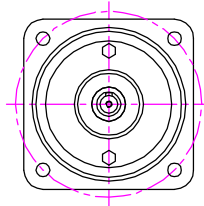

IEC 56 B14 Ø80
IEC 63 B14 Ø90
IEC 71 B14 Ø105

Tipo / Type	L	Coppia a rotore bloccato / Continuous stall torque	Tensione a / Voltage at 1000min ⁻¹
MP66S	150	0.7 Nm	16V - 24V - 40V - 53V - 80V
MP66M	197	1.4 Nm	16V - 24V - 40V - 53V - 80V
MP66L	242	2.1 Nm	16V - 24V - 40V - 53V - 80V



OPZIONI :

- Flange e alberi speciali
- Freno di sicurezza esteno
- Dinamo tachimetrica
- Encoder
- Cavo o morsettiera

OPTIONS :

- Special shafts and flanges
- External safety brake
- Tachogenerator
- Encoder
- Cable or terminal board

Servomotori C.C. - Coppia da 1.5Nm a 4.1Nm D.C. Servomotor - Torque from 1.5Nm to 4.1Nm

CARATTERISTICHE PRINCIPALI

- Servomotori C.C. a norme CEI ed IEC.
- 2 o 4 poli - magnete permanente.
- Grado di protezione IP54.
- Isolamento classe F e H.
- Cavo.

MAIN FEATURES

- D.C. servomotors according to CEI and IEC standards.
- 2 or 4 poles - permanent magnet.
- Degree of protection IP54.
- Insulation F and H class.
- Cable.

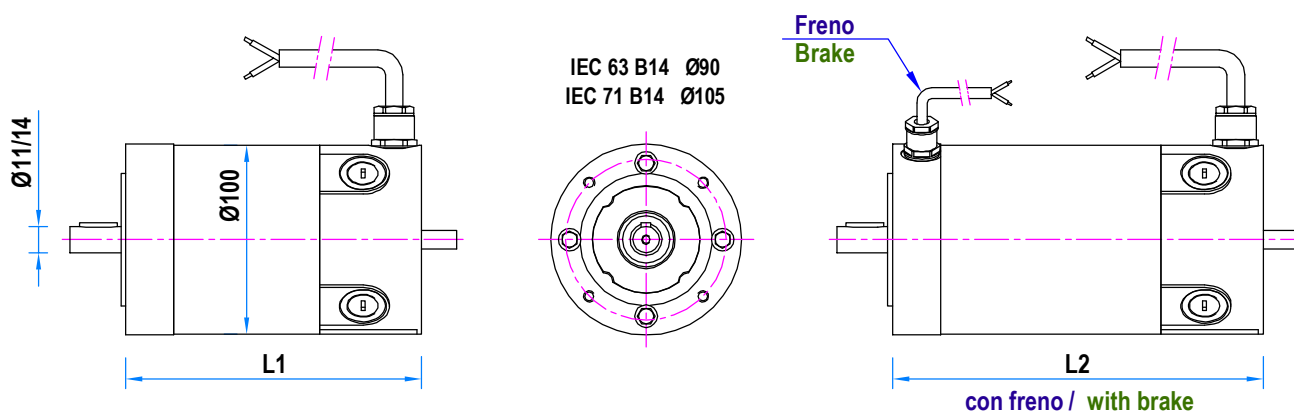

Tipo / Type	L1	L2	Coppia a rotore bloccato / Continuous stall torque	Tensione a / Voltage at 1000min ⁻¹
MP70S	156.5	187	1.5 Nm	24V - 32V - 40V - 53V
MP70M	206.5	237	2.9 Nm	24V - 32V - 40V - 53V
MP70L	256.5	287	4.1 Nm	24V - 32V - 40V - 53V



OPZIONI :

- Flange e alberi speciali
- Freno di sicurezza interno o esterno
- Dinamo tachimetrica
- Encoder
- Connettore max. 15A
- Protezione IP66

OPTIONS :

- Special shafts and flanges
- Inside or external safety brake
- Tachogenerator
- Encoder
- Connectors max. 15A
- IP66 protection

MP77

Servomotori C.C. - Coppia da 1.5Nm a 8Nm

D.C. Servomotor - Torque from 1.5Nm to 8Nm

CARATTERISTICHE PRINCIPALI

- Servomotori C.C. a norme CEI ed IEC.
- 4 poli - magnete permanente.
- Grado di protezione IP54.
- Isolamento classe F e H.
- Morsettiera.

MAIN FEATURES

- D.C. servomotors according to CEI and IEC standards.
- 4 poles - permanent magnet.
- Degree of protection IP54.
- Insulation F and H class.
- Terminal board.

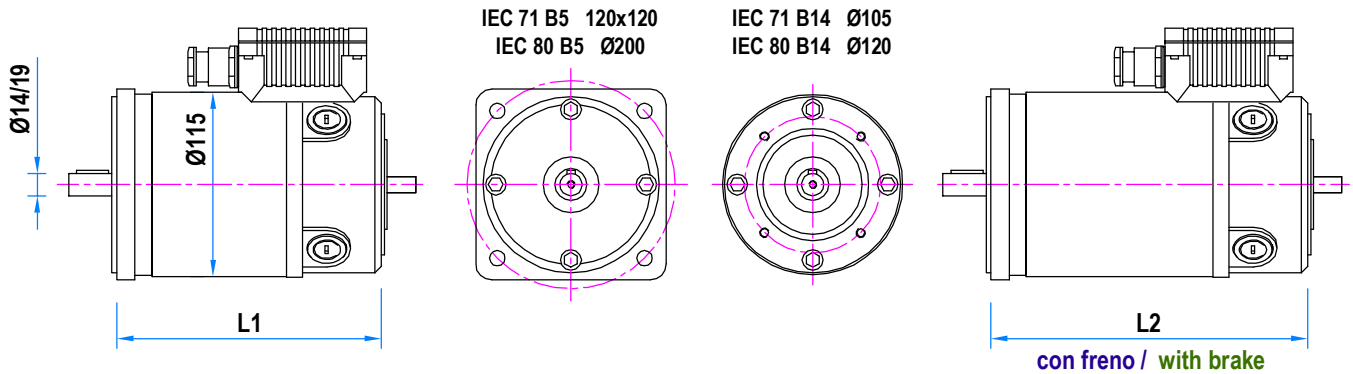
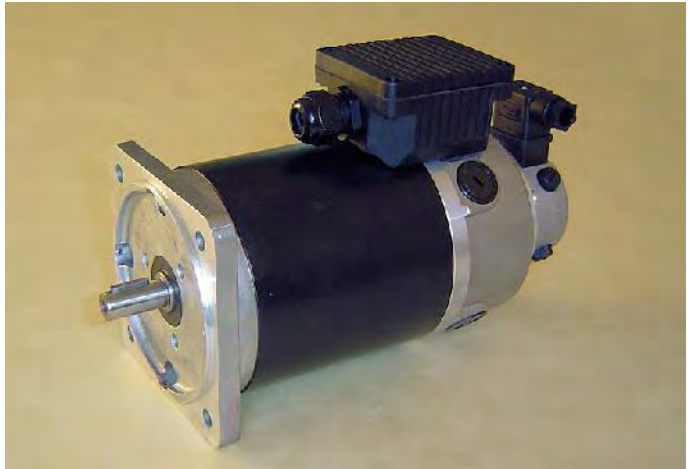

Tipo / Type	L1	L2	Coppia a rotore bloccato / Continuous stall torque	Tensione a / Voltage at 1000min ⁻¹
MP77K	158	193	1.5 Nm	24V - 30V - 40V - 53V
MP77S	192	227	2.8 Nm	30V - 40V - 53V - 80V - 107V
MP77M	222	257	4.1 Nm	30V - 40V - 53V - 80V - 107V
MP77L	252	287	5.5 Nm	30V - 40V - 53V - 80V - 107V
MP77XL	307	342	8 Nm	40V - 53V - 80V - 107V

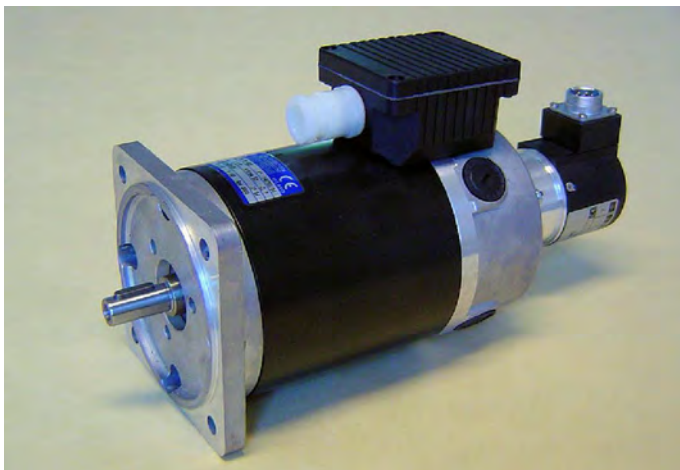

OPZIONI :

- Flange e alberi speciali
- Freno di sicurezza interno o esterno
- Dinamo tachimetrica
- Encoder
- Cavo

OPTIONS :

- Special shafts and flanges
- Inside or external safety brake
- Tachogenerator
- Encoder
- Cable