

Series Select Lube Free Multi-Vane Air Motors

Specifications



Series	Max Power		Speed at Max Power	Free Speed	Starting Torque		Stall Torque		Air Consumption at Max. Power		Weight	
	hp	kw	rpm	rpm	lb.-ft.	Nm	lb.-ft.	Nm	scfm	m³/m	lb.	kg
reversible												
SM1AMA	0.33	0.25	7600	15,200	0.29	0.39	0.38	0.52	17	0.5	1.5	0.7
SM1AMAL	0.33	0.25	7600	15,200	0.29	0.39	0.38	0.52	17	0.5	1.5	0.7
SM1UPC	0.60	0.37	6000	12,500	0.45	0.6	0.6	0.81	42	1.2	1.75	0.8
SM1UPCL	0.60	0.37	6000	12,500	0.45	0.6	0.6	0.81	42	1.2	1.75	0.8
SM1UPCR	0.60	0.37	6000	12,500	0.45	0.6	0.6	0.81	42	1.2	1.75	0.8
SM2AMAN	0.88	0.66	3000	8070	1.7	2.3	2.3	3.1	48	1.4	7.5	3.4
SM2AMC	0.88	0.66	3000	8070	1.7	2.3	2.3	3.1	48	1.4	7.5	3.4
SM4AMAN	1.5	1.1	3000	7900	2.6	3.5	4.1	5.6	67	1.9	8.25	3.7
SM4AMB	1.5	1.1	3000	7900	2.6	3.5	4.1	5.6	67	1.9	8.25	3.7
SM6AMA	3.6	2.7	3000	7900	5.3	7.2	8.7	11.8	120	3.4	16.25	7.4
SM6AMAN	3.6	2.7	3000	7900	5.3	7.2	8.7	11.8	120	3.4	16.25	7.4
SM8AMA	4.8	3.6	2500	7000	10	13.6	14	19	152	4.3	22.5	10.2
SM8AMAN	4.8	3.6	2500	7000	10	13.6	14	19	152	4.3	22.5	10.2

Model Designation Breakout

Select Series Air Motor	Power Series	Shaft/Interface	Rotation	Mounting
SM	2AM	A		N
	1AM 1UP 2AM 4AM 6AM 8AM	A = Round shaft w/ square key (Round shaft on SM1AM series) B = Round shaft with Woodruff Key (#3) C = Round shaft with flat on the shaft	L=Left Hand Bias (CCW)* R=Right Hand Bias (CW)* None=Reversible *when facing shaft	N=NEMA mount None= Face or Footmount (Footmount is an optional accessory)

Equipment Options

Series	Furnished with Cataloged Models	Optional Accessories
SM1AM	Hub Mounting Muffler	SM1AM-AG587 Footmount
SM1UP	Hub Mounting Muffler	SM1AM-AG587 Footmount
SM2AM	3 Hole Face Mounting Muffler NEMA 56C Flange with Model SM2AMAN	SM2AM-AH636 Footmount
SM4AM	3 Hole Face Mounting Muffler NEMA 56C Flange with Model SM4AMAN	SM4AM-AH634 Footmount
SM6AM	3 Hole Face Mounting Muffler NEMA 56C Flange with Model SM6AMAN	SM6AM-AH634 Footmount
SM8AM	4 Hole Face Mounting Muffler NEMA 182C Flange, 184C Flange Mount with Model SM8AMAN	SM8AM-AH640 Footmount

Interchange Chart

GAST Model Style	Rotation Bias	FENNER Model Style	IR SELECT Series Model Style (w/ Foot Bracket)	Max. Power (hp)	Max. Free Speed (rpm)	Mounting Style
1AM-NCC-12	Left Hand (CCW)		SM1AMAL	0.33	15,200	Hub Mount
1AM-NCW-14	Right Hand (CW)		SM1AMA	0.33	15,200	Hub Mount
1AM-NRV-39A	Reversible		SM1AMA	0.33	15,200	Hub Mount
1AM-NRV-63A	Reversible		SM1AMA	0.33	15,200	Hub Mount
1UP-NCC-1A	Left Hand (CCW)		SM1UPCL	0.60	12,500	Hub Mount
1UP-NCW-2A	Right Hand (CW)		SM1UPCR	0.60	12,500	Hub Mount
1UP-NRV-3A	Reversible	V1X	SM1UPC	0.60	12,500	Hub Mount
1UP-NRV-10 AG585	Reversible 1AM Foot Mount Bracket		SM1UPC (SM1AM-AG587)	0.60	12,500	Hub Mount
2AM-NCC-16	Left Hand (CCW)	2VMX/CCW	SM2AMC	0.88	8,070	Hub or Face Mount
2AM-NCC-16F	Left Hand (CCW)		SM2AMC	0.88	8,070	Hub or Face Mount
2AM-NCW-7A	Right Hand (CW)	2VMX/CW	SM2AMC	0.88	8,070	Hub or Face Mount
2AM-NCW-7B	Right Hand (CW)		SM2AMC	0.88	8,070	Hub or Face Mount
2AM-NRV-89	Reversible	VA2X	SM2AMC	0.88	8,070	Hub or Face Mount
2AM-FCC-1	Left Hand (CCW)	2VMJ/CCW	SM2AMC (w/ SM2AM-AH636)	0.88	8,070	Foot Mount
2AM-FCW-13	Right Hand (CW)	2VMJ/CW	SM2AMC (w/ SM2AM-AH636)	0.88	8,070	Foot Mount
2AM-FRV-501	Reversible	VA2J	SM2AMC (w/ SM2AM-AH636)	0.88	8,070	Foot Mount
2AM-NCC-43A	Left Hand (CCW)	2VMC/CCW	SM2AMAN	0.88	8,070	NEMA 56C Mount
	Right Hand (CW)	2VMC/CW	SM2AMAN	0.88	8,070	NEMA 56C Mount
2AM-NRV-90	Reversible	VA2C	SM2AMAN	0.88	8,070	NEMA 56C Mount
	Left Hand (CCW)	4VMX/CCW	SM4AMB	1.5	7,900	Hub or Face Mount
	Right Hand (CW)	4VMX/CW	SM4AMB	1.5	7,900	Hub or Face Mount
4AM-NRV-22B	Reversible	VA4X	SM4AMB	1.5	7,900	Hub or Face Mount
4AM-NRV-22F	Reversible		SM4AMB	1.5	7,900	Hub or Face Mount
4AM-NRV-54A	Reversible		SM4AMB	1.5	7,900	Hub or Face Mount
	Left Hand (CCW)	4VMJ/CCW	SM4AMB (w/ SM4AM-AH634)	1.5	7,900	Foot Mount
	Right Hand (CW)	4VMJ/CW	SM4AMB (w/ SM4AM-AH634)	1.5	7,900	Foot Mount
4AM-FRV-13C	Foot Mount	VA4J	SM4AMB (w/ SM4AM-AH634)	1.5	7,900	Foot Mount
4AM-FRV-13H	Foot Mount		SM4AMB (w/ SM4AM-AH634)	1.5	7,900	Foot Mount
4AM-FRV-63A	Foot Mount		SM4AMB (w/ SM4AM-AH634)	1.5	7,900	Foot Mount
	Left Hand (CCW)	4VMC/CCW	SM4AMAN	1.5	7,900	NEMA 56C Mount
	Right Hand (CW)	4VMC/CW	SM4AMAN	1.5	7,900	NEMA 56C Mount
4AM-NRV-50C	Reversible	VA4C	SM4AMAN	1.5	7,900	NEMA 56C Mount
4AM-NRV-70C	Reversible		SM4AMAN	1.5	7,900	NEMA 56C Mount
6AM-NRV-7A	Reversible	VA6X	SM6AMA	3.6	7,900	Face Mount
6AM-FRV-5A	Reversible	VA6J	SM6AMA (w/ SM6AM-AH634)	3.6	7,900	Foot Mount
6AM-FRV-23A	Reversible		SM6AMA (w/ SM6AM-AH634)	3.6	7,900	Foot Mount
6AM-NRV-11A	Reversible	VA6C	SM6AMAN	3.6	7,900	NEMA 56C Mount
6AM-NRV-22A	Reversible		SM6AMAN	3.6	7,900	NEMA 56C Mount
8AM-NRV-5B	Reversible	VA8X	SM8AMA	4.8	7,000	Face Mount
8AM-NRV-42A	Reversible		SM8AMA	4.8	7,000	Face Mount
8AM-FRV-2B	Reversible	VA8J	SM8AMA (w/ SM8AM-AH640)	4.8	7,000	Foot Mount
8AM-FRV-30A	Reversible		SM8AMA (w/ SM8AM-AH640)	4.8	7,000	Foot Mount
8AM-NRV-28A	Reversible	VA8C	SM8AMAN	4.8	7,000	NEMA 145TC Mount
8AM-NRV-32A	Reversible		SM8AMAN	4.8	7,000	NEMA 145TC Mount

NOTE: All Select Series motors are provided in our Lube Free Four Vane design.

SM1AM and SM1AM-AG587 Lube Free Multi-Vane Air Motors Footmount Dimensions

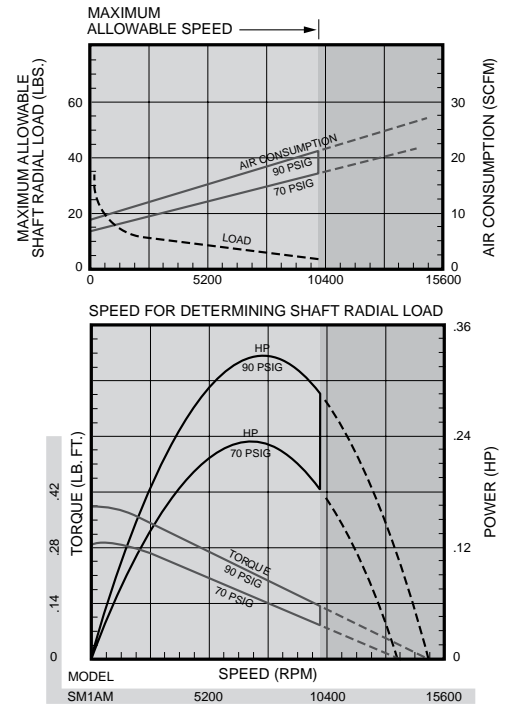
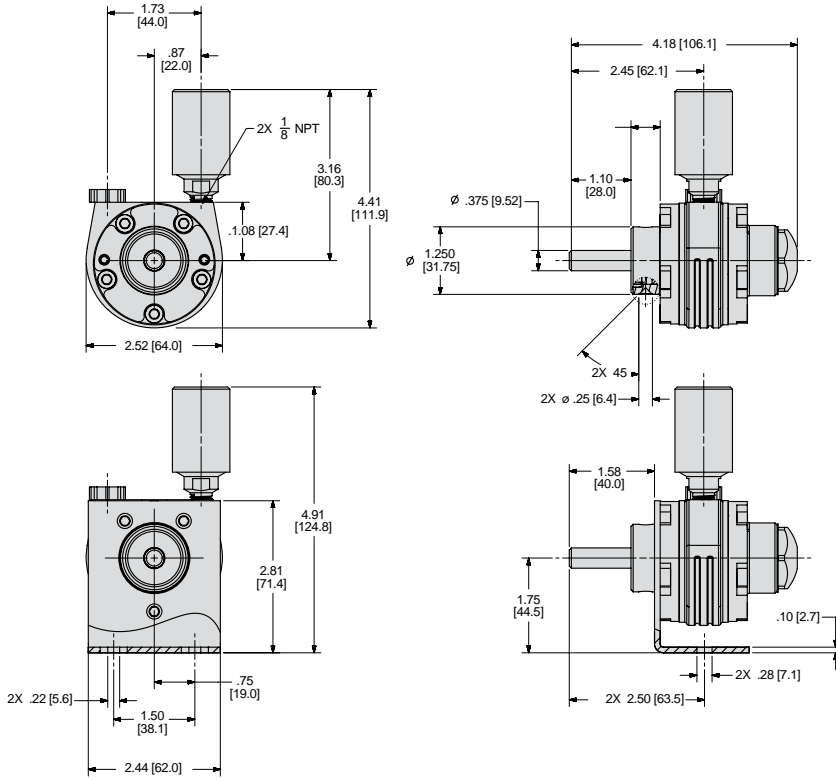

SM1UP and SM1AM-AG587 Lube Free Multi-Vane Air Motors Footmount Dimensions

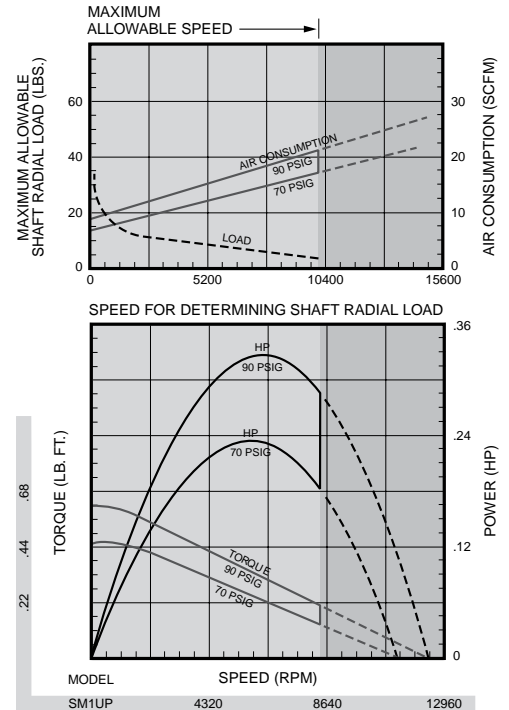
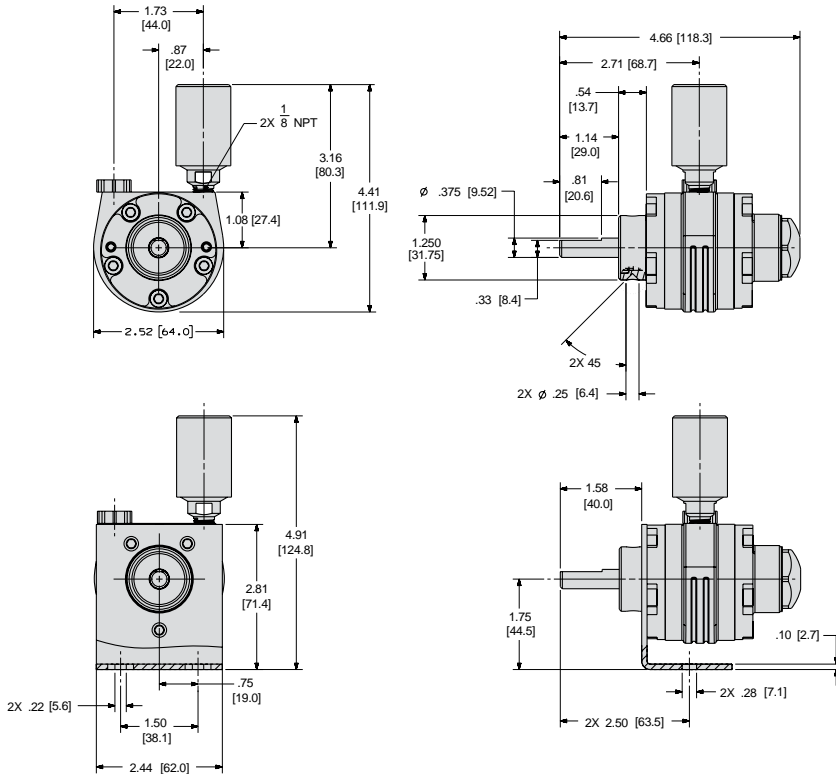

SM2AMC and SM2AM-AH636 Lube Free Multi-Vane Air Motors Footmount Dimensions

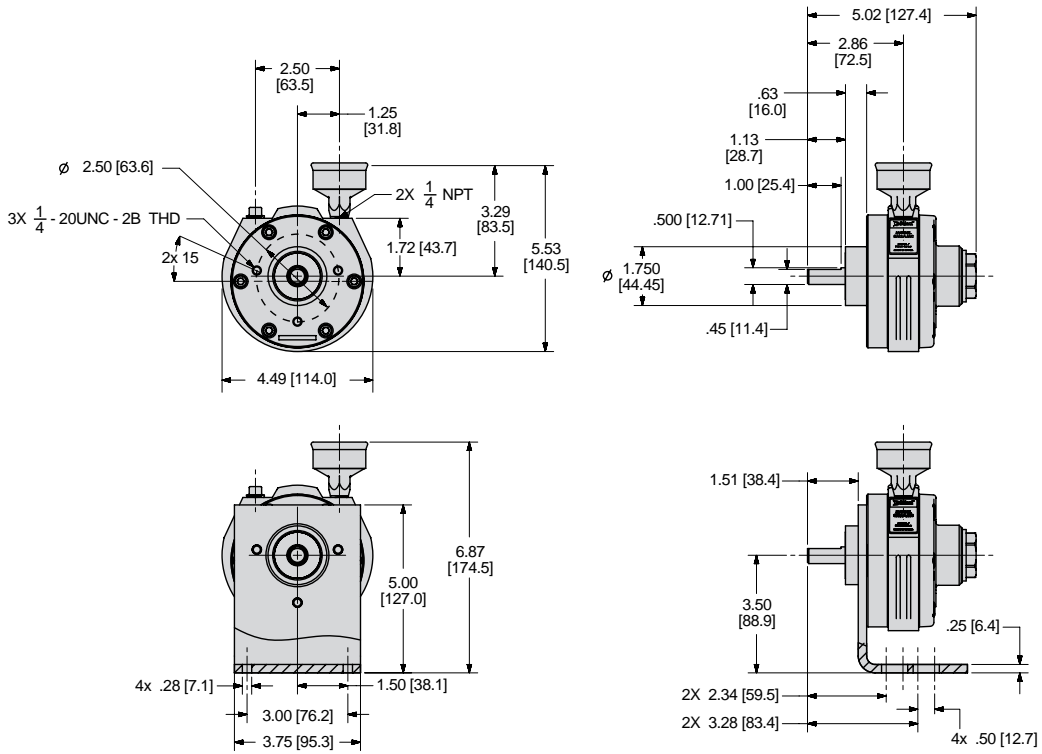

SM2AMAN Lube Free Multi-Vane Air Motors NEMA Mount Dimensions

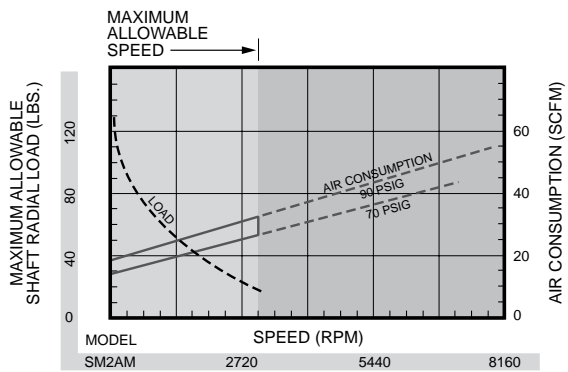
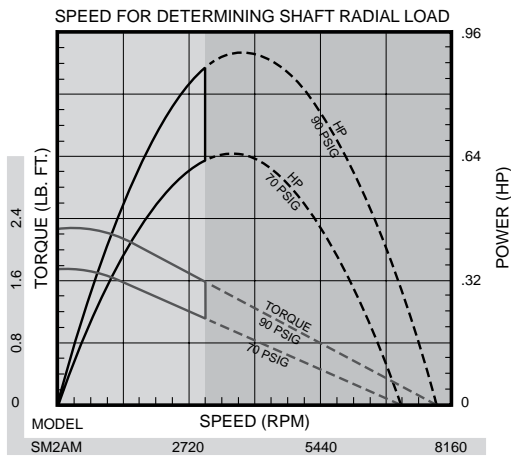
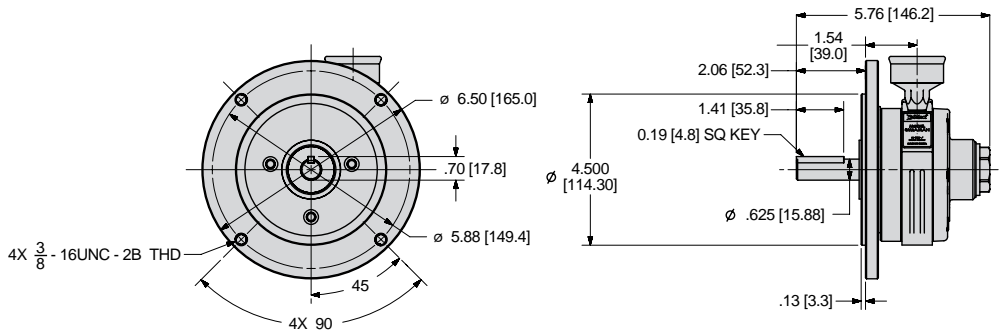

SM4AMB and SM4AM-AH634 Lube Free Multi-Vane Air Motors Footmount Dimensions

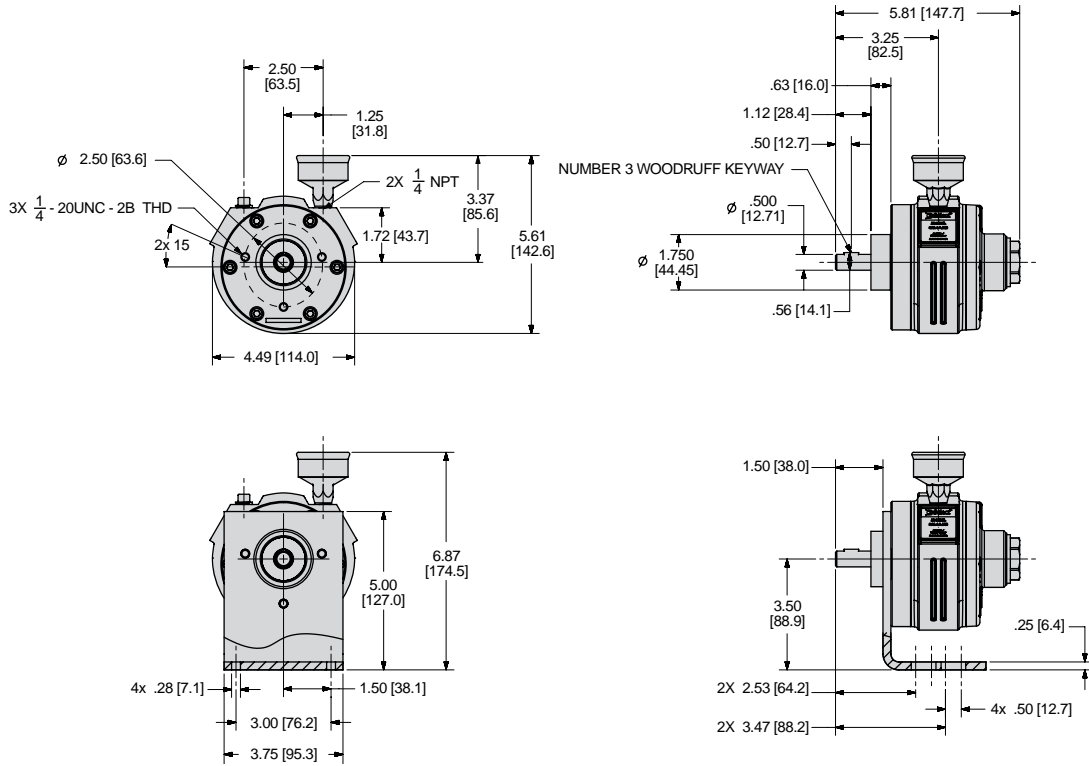

SM4AMAN Lube Free Multi-Vane Air Motors NEMA Mount Dimensions

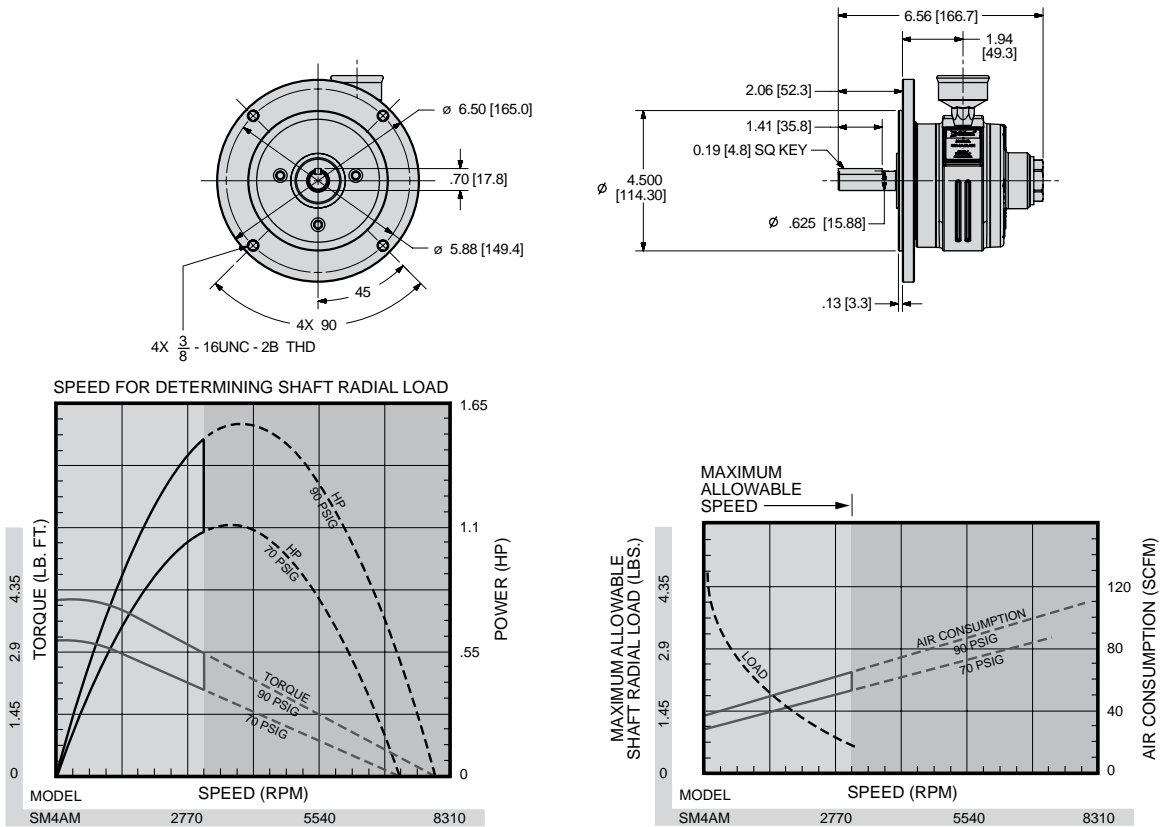

SM6AMA and SM6AM-AH636 Lube Free Multi-Vane Air Motors Footmount Dimensions

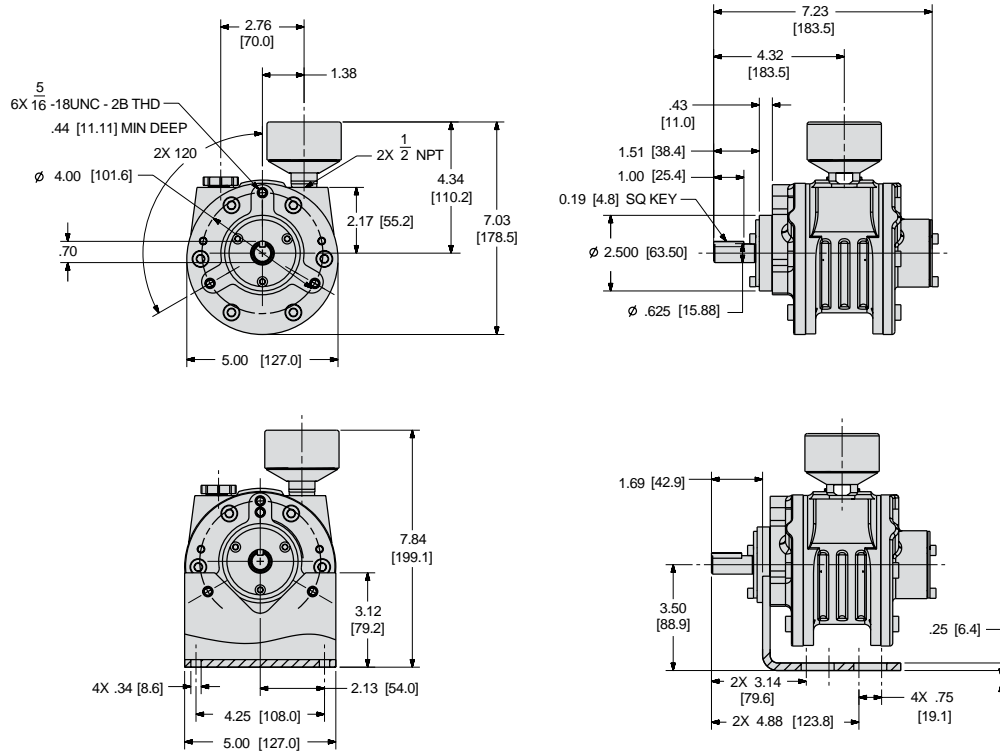

SM6AMAN Lube Free Multi-Vane Air Motors NEMA Mount Dimensions

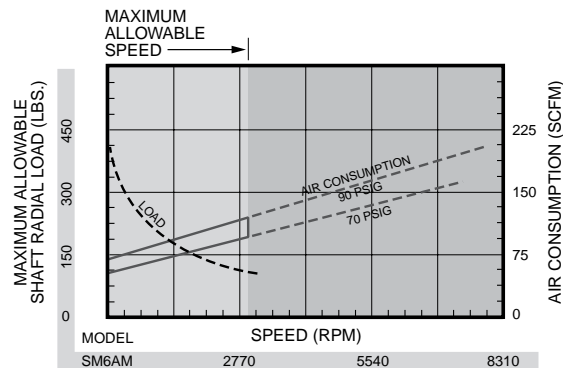
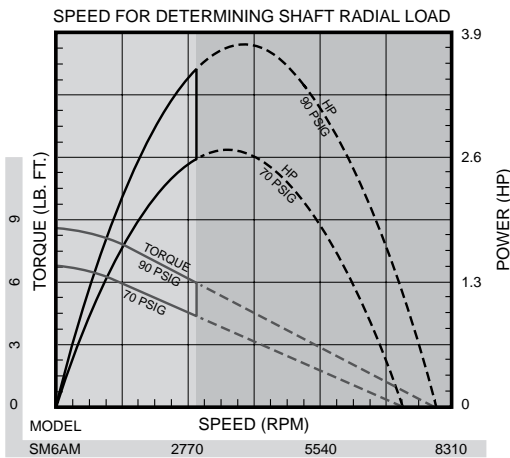
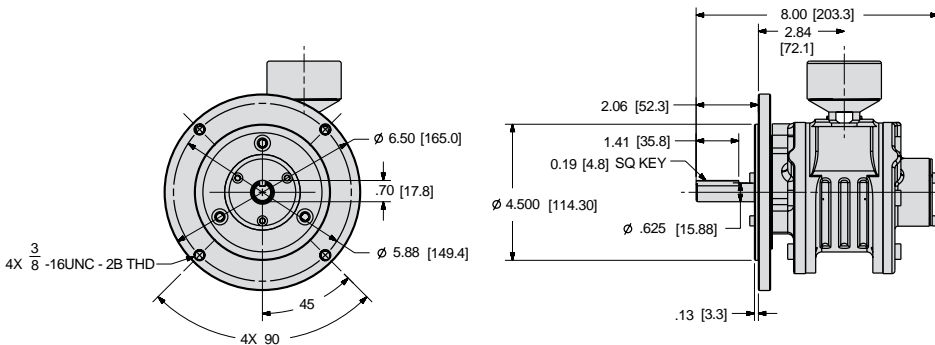

SM8AMA and SM8AM-AH640 Lube Free Multi-Vane Air Motors Footmount Dimensions

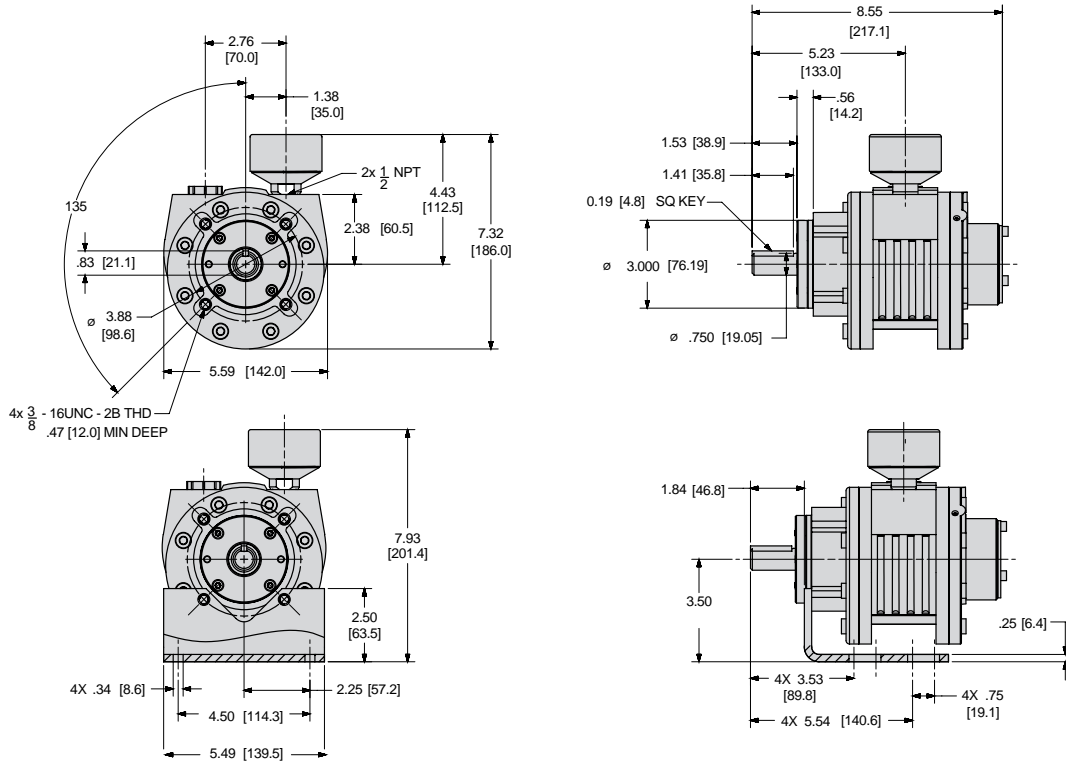

SM8AMAN Lube Free Multi-Vane Air Motors NEMA Mount Dimensions

