

Model RFA Tension Transducer

The RFA Tension Transducers measure actual tension in any moving narrow web, ribbon or filament. RFA Transducers are ideal for measuring process tension in materials such as wire, plastic, rubber, metal, glass and composites.

Tension is measured by high performance strain gages embedded on a dual cantilevered beam and connected in a full wheatstone bridge configuration. As the ribbon or filament passes over a rotating wheel assembly coupled to the end of the transducer, the beam deflects slightly in response to tension. This produces a voltage signal proportional to tension. The RFA transducer mounts cantilevered to a machine frame and may be connected to an indicator or controller for display or automatic control of web tension.

Three standard wheels are available: one for ribbon, one for filament, and an adapter wheel for custom requirements. The three mounting styles available are single bolt, flange, and pillow block.

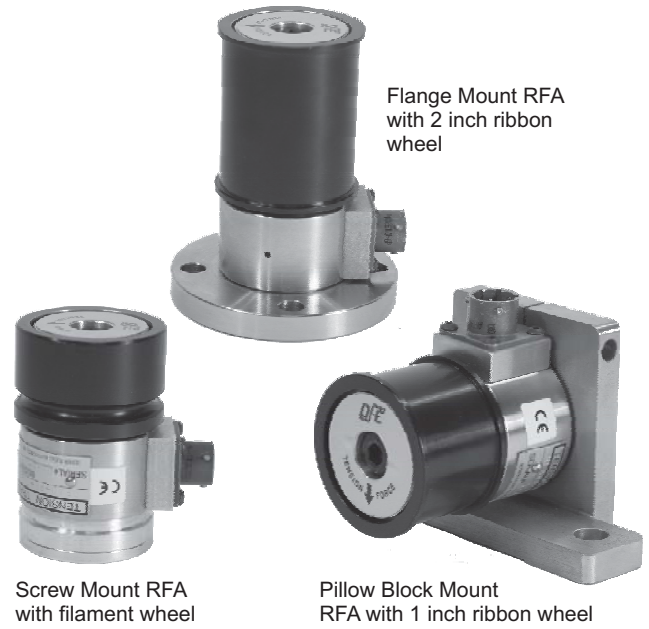

FEATURES

- Small enough to meet tight space requirements.
- Versatile and easy-to-install.
- Wheel face lengths to 4" maximum.
- High performance design and materials for long life in any web or filament application.
- Load Ratings from 10 - 150 lbs (45 - 667N) with wide operating range.

BENEFITS

- Accurate tension measurement of any narrow web, ribbon or filament.
- Improved product quality and consistency from any web or filament process.
- Reduced material waste.
- Higher production with less downtime.

OPTIONS

- **Extended Range (XR).** Produces twice the output signal for a given load rating. Electronics must have extended range also.
- **Metric Mounting Stud (MMS).** DFE's standard metric mounting stud, M10 x 1.5. (S mounting style only).

ACCESSORIES

- **Cables.** Transducer cables are available in lengths of 15, 20, 25, or 30 feet. Special lengths can also be ordered. Your DFE Applications Engineer will help you select the proper cable for your application.

ORDERING INFORMATION

You may order from description or by specifying the code below by matching each labeled digit with one of the choices given. **Example: RFA0-S-25-F-6-MMS, XR**

RFA 0 - S - 25 - F - 6 - OPTIONS (Separated by commas)

SIZE	MOUNTING STYLE	LOAD RATING	WHEEL	CONNECTOR POSITION	OPTIONS
0	S = Screw/bolt FL = Flange PB = Pillow Block	10 lbs. ² 25 lbs. 50 lbs. 100 lbs. 150 lbs.	R1 = 1" Ribbon R2 = 2" Ribbon R3 = 3" Ribbon R4 = 4" Ribbon F = Filament A = Adapter N = No wheel Z = Custom	6:00 (Standard) 1:30 3:00 4:30 7:30 9:00 10:30 12:00 R (Rear-PB only)	MMS = Metric Mounting Stud XR = Extended Range ¹ Z = Special

NOTES: 1. XR option requires electronics to have XRE option. 2. The 10 pound load rating is not available on the R4 wheel.

SPECIFICATIONS:

Excitation Voltage: 5 Vdc (10Vdc with XR option)

Output: 500mVdc nominal, at rated load
(1000 mVdc with XR option)

Strain Gauges: Semiconductor, 120 ohms (± 20 ohms), nominal resistance

Non-Repeatability: $\pm 1/4\%$ full span (FS)

Non-Linearity and Hysteresis Combined: $\pm 1/2\%$ FS

Maximum Overload Capacity: 4 times the load rating

Temperature Range: -10°F to 200°F (-23°C to 93°C)

Deflection: 0.005" typical (0.127mm typical)

Temperature Coefficient:

0.02% per degree F typical

(0.01% per degree C typical)

Load Ratings: 10, 25, 50, 100, 150, lbs.

(45, 111, 222, 445, 667 N)

Electrical Connector: ITT Canon KPT02E10-6P

Mating Electrical Connector: ITT Canon KPT06F10-6S

Connector Pin Assignments:

Pin A = negative output (WHT) Pin B = 5V+ (BLK)

Pin C = 5V- (RED)

Pin D = positive output (GRN)

Pin E = 5V- (BLU)

Pin F = 5V+ (BRN)

Break Away Torque: 0.25 in-oz (18 gram-cm) typical

Standard Connector Position:

Styles S & FL = 6 o'clock with reference to force direction

Basic Dynamic Load Rating of Bearings:

4300 lbs. (19127 N)

Wheel Weights:

Filament = 0.49 lbs (222 g), Ribbon = 0.45 lbs. (204 g),

Adapter = 0.65 lbs. (295 g)

Materials:

Transducer = Stainless Steel & Aluminum

Wheel (except adapter) = Aluminum, hard coat anodized

SELECTION OF LOAD RATING:

The correct transducer load rating for your application is determined by maximum web tension, wrap angle, and wheel weight. Choose the appropriate wrap configuration from the diagrams below. Then compute the Net Force using the formula below the diagram.

In some cases the load rating may be less than the computed Net Force. This may be acceptable because the Net Force formula contains an oversizing factor of 2, which means that the actual force exerted on the transducer will not exceed its rating.

The following applies only to non-standard wheels or other hardware used in place of the wheel:

Sometimes a wheel is so heavy that its weight uses up most of the operating range of the transducer. When this happens, it may not be possible to adjust the tension

indicating meter to read zero when tension is zero because the adjustment range of the electronic circuit has been exceeded. To find out if the wheel is too heavy, compare the load rating with the effective weight of the wheel as follows: The effective wheel weight is the "W COS (A)" term in the formula. If W COS (A) is more than 95% of the load rating chosen, the tension meter will probably not be adjustable to zero. If this is the case, one or more of the following changes must be made to reduce W COS (A) to less than 95% of the load rating:

1. Reduce the transducer wheel weight.
2. Increase angle (A).
3. Use the next higher load rating (this is the least desirable choice because it reduces transducer signal output).

WRAP 1

Tension Force F_T , above horizontal

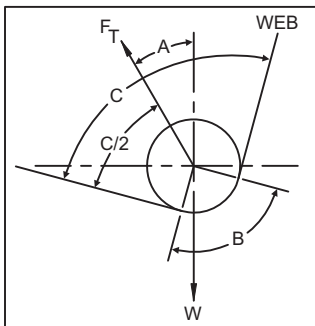

$$\text{NET FORCE} = 4T \sin\left(\frac{B}{2}\right) - W \cos(A)$$

WRAP 2

Tension Force F_T , below horizontal

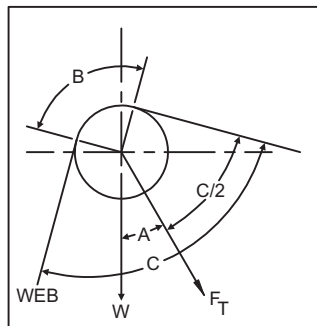

$$\text{NET FORCE} = 4T \sin\left(\frac{B}{2}\right) + W \cos(A)$$

WRAP 3

Tension Force F_T , is horizontal

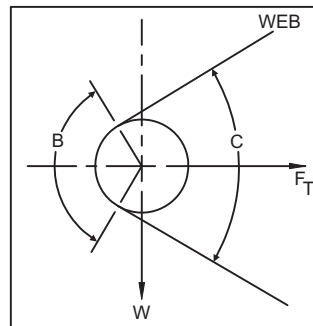

$$\text{NET FORCE} = 4T \sin\left(\frac{B}{2}\right)$$

TABLE 1

Angle (Degrees)	SINE	COSINE
0	.000	1.000
5	.087	.996
10	.174	.985
15	.259	.966
20	.342	.940
25	.423	.906
30	.500	.866
35	.574	.819
40	.643	.766
45	.707	.707
50	.766	.643
55	.819	.574
60	.866	.500
65	.906	.423
70	.940	.342
75	.966	.259
80	.985	.174
85	.996	.087
90	1.000	.000

W = idler roll weight, T = Maximum web tension, B = Wrap angle = $180^{\circ} - C^{\circ}$, A = Angle between Tension Force F_T and vertical

NOTE: Weight of standard filament wheel is 0.49 lbs. (222 grams) including bearings and fasteners.

Weight of standard ribbon wheel is 0.45 lbs. (204 grams) including bearings and fasteners.

Weight of standard adapter wheel is 0.65 lbs. (295 grams) including bearings and fasteners.

Weight of customer supplied wheel must be provided and is subject to DFE engineering approval.

DIMENSIONS Inches (mm)

STANDARD MOUNTING STYLE S

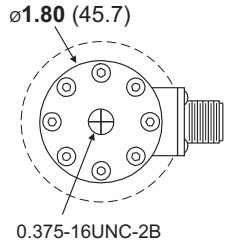
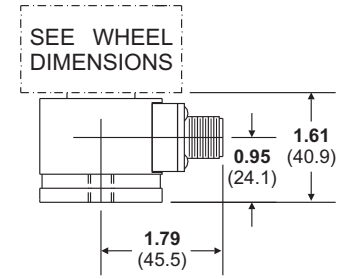

OPTIONAL MOUNTING STYLE FL Flange may be rotated

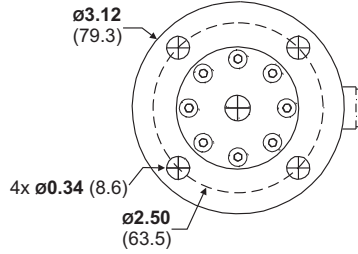
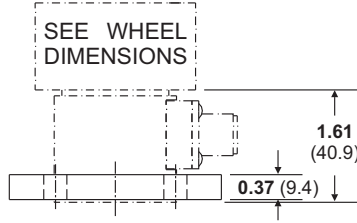

OPTIONAL MOUNTING STYLE PB

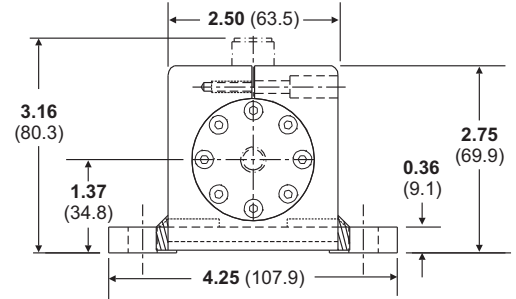
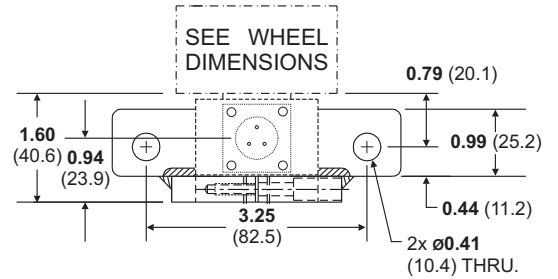

WHEEL DIMENSIONS Inches (mm)

RIBBON WHEEL

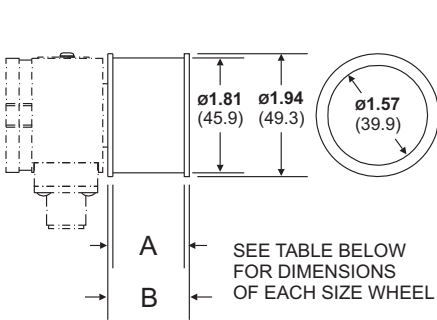

FILAMENT WHEEL

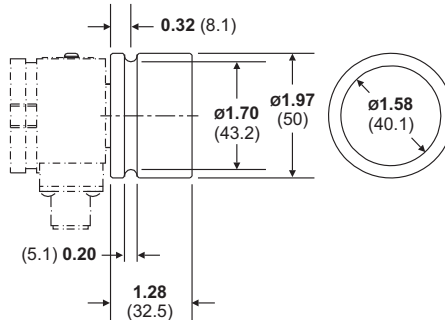

ADAPTER WHEEL

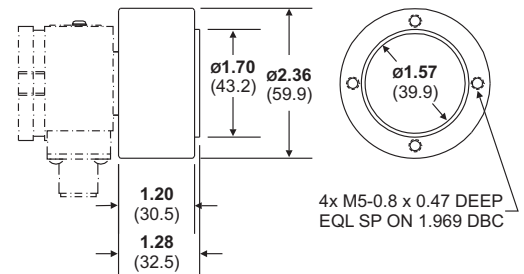

		RIBBON WHEEL SIZES			
		1	2	3	4
A	in.	1.13	2.13	3.13	4.13
	mm	28.7	54.1	79.5	104.9
B	in.	1.28	2.28	3.28	4.28
	mm	32.5	57.9	83.3	108.7

