



VAHLE POWERCOM® 485

Digital Data Transmission System



VAHLE POWERCOM® 485

Digital Data Transmission using VAHLE Conductor Systems

VAHLE POWERCOM® 485 is the latest development of the well-known VAHLE POWERCOM® data communication systems, first introduced in 1984. It was especially designed for RS 485 based industrial data bus systems with decentral control and operates at a data rate of 19.2 Kbit/s.

With new generation electronic components the dimensions of the VAHLE POWERCOM® 485 could be substantially reduced and the top-hat rail housing comprises the necessary power supply equipment. The compact design simplifies installation, e.g. on electrical overhead mono-rails.

VAHLE POWERCOM® 485 has on its front an integrated transparent RS 485 interface in accordance with PROFIBUS, below the power supply 230 V, 50 Hz, or alternatively 115 V, 60 Hz, and the 2-pole connection for the conductor system. Three-status LED inform about the status of the unit.

VAHLE POWERCOM® 485 provides safe communication for RS 485 industrial data bus systems using VAHLE conductor systems up to 5000 m length, including switches, turntables, lifting stations etc. The data rate is 19.2 Kbit/s with an internal delay of max. 3 bits. It can be used for point-to-point transmission and for bus systems with up to 31 partners.

A variety of system layouts is possible, including trans- fers, isolating sections etc. VAHLE POWERCOM® 485 is the ideal communication link for electric overhead mono- rails, straight and curved AS/RS systems, slipping bodies and other track-guided material handling equipment.

All VAHLE conductor systems can be used together with VAHLE POWERCOM® 485. Since there is a mobile com- munication at VAHLE POWERCOM® 485 we recommend to set the message repetition rate to 3. This has no influ- ence to the general data communication, because the repetition function occurs only in case of an error.

For the implementation of data systems with higher transmissiion speeds up to 10 Mbit/s and other industrial data bus systems we recommend our SMG (Slotted Microwave Guide).

- Applications:**
- Cranes
 - AS/RS Systems
 - Transfer Cars
 - Electric Monorail Systems
 - Motorized and Spring Driven Reels



VAHLE POWERCOM® 485

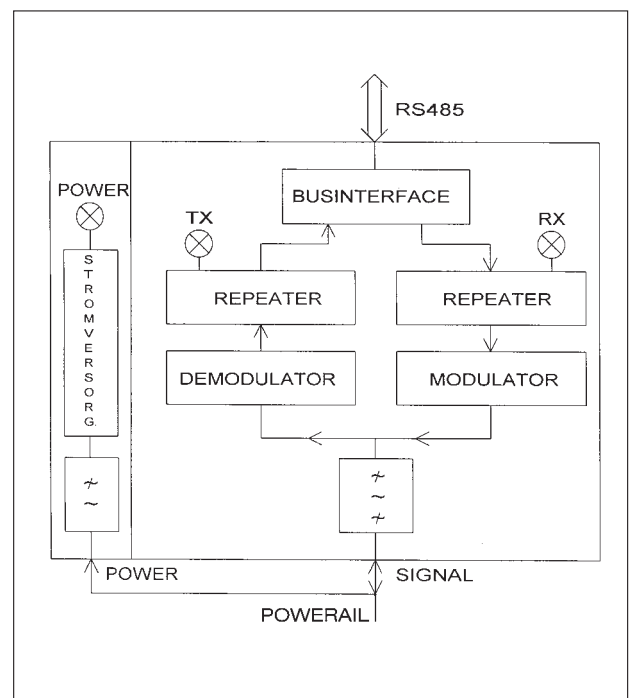

Block diagram



Technical Data:

Transmission network:	half duplex (HDx)
Transmission speed:	19.2 Kbit/s.
Number of stations:	At specification of the used network
Suitable networks:	all networks with decentral control like e.g.: Profibus-DP and FMS, EN 50 170 Vol. 2 PPI (Point to Point Interface) MPI (Multipoint Interface) Modbus Allen-Bradley DH 485 and all other RS 485 Networks with 11 or 10 bits/byte

Data line (VPC 485 – PLC): Shielded twisted pair data line (as recommended by the PLC manufacturer)

Data line (VPC 485 – conductor rail system – VPC 485):	Shielded power cable (2 x 2.5 mm ²)
Indications:	Status check for POWER, RX and TX
Supply voltage:	230 V, 50 Hz alternatively 115 V, 60 Hz
Voltage drop:	± 10 % max.
Operating temperature:	– 20° to + 50° C, – 4° to 122° F
Storage temperature:	0° to 70° C, 32° to 158° F
Enclosure dimensions:	85 x 117 x 110 mm (W x H x D) Mounting position vertical, ventilation slots at the top and at the bottom, minimum clearance to other modules 30 mm

Protection against direct contact:	IP 20
Weight:	1.1 kg
Mounting:	Back side to top-hat rail EN 50-022-35.

Cat.-No. Profibus 19.2 Kbit/s, 230 V: 910 108

Cat.-No. Profibus 19.2 Kbit/s, 115 V: 910 109

Other versions on request.

Circuit Diagram VAHLE POWERCOM® 485

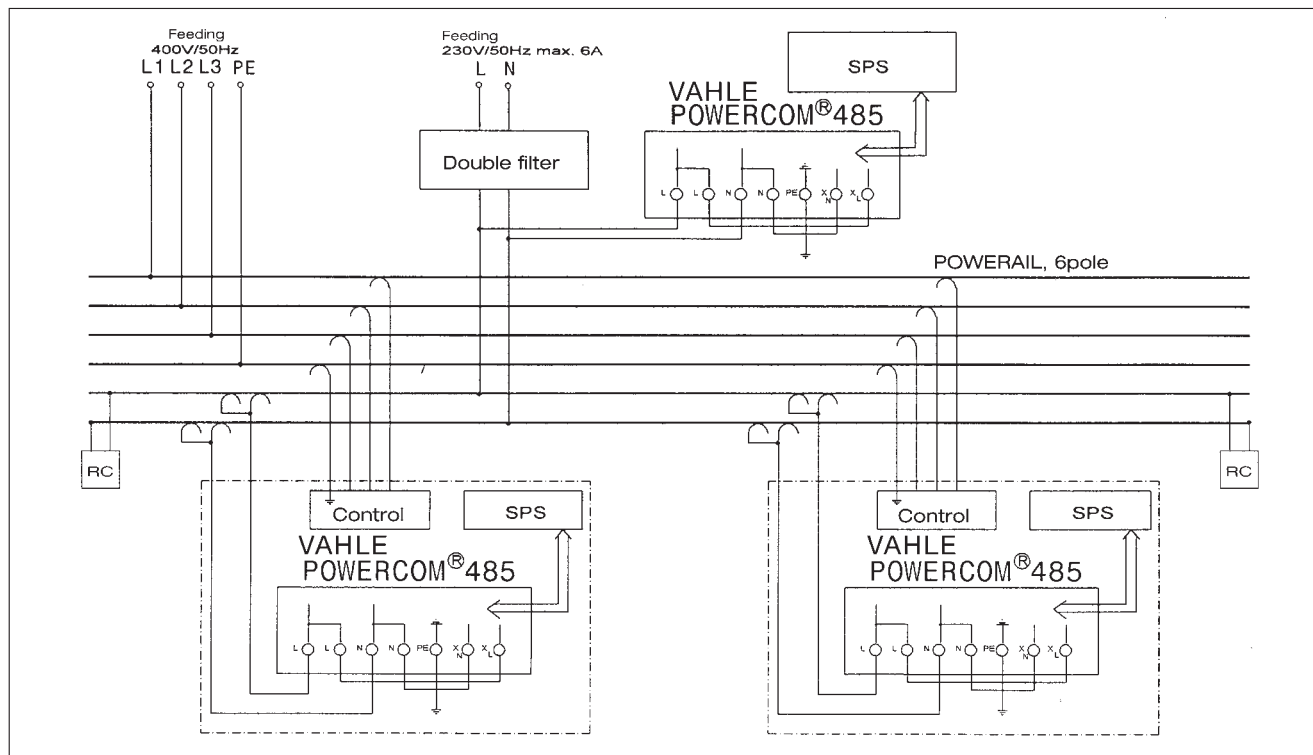



ACCESSORIES

Filter for VAHLE POWERCOM® System

Prevents interference from reaching the data network and prevents data from travelling into the remaining network

Current: 6 A max. (fuse)
Voltage: 230 VAC
Dimensions: 85 x 117 x 110 mm (W/H/D)
Weight: 1.3 kg

Order No.: 910 080



Power supply limit for VAHLE POWERCOM® System

To isolate the data circuit from site related interference if the use of our 6 A double filter is not possible.

Power supply: 6 A
Voltage: 230 VAC
Dimensions: 48 x 95 x 57 mm
Weight: 0.150 kg

Order No.: 910 032

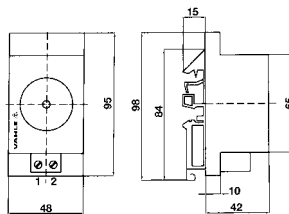

Cables and connectors available on request.

Installation Information:

For systems with frequency converters, it is important to follow the unit manufacturer's instructions, especially with measures against interference, cable support and cable shielding. Data cables must be separated at least 100 mm from the power cables.



VAHLE POWERCOM® -data transmission for coil transport system in an aluminium plant.



VAHLE POWERCOM®-data transmission at a brick kiln.

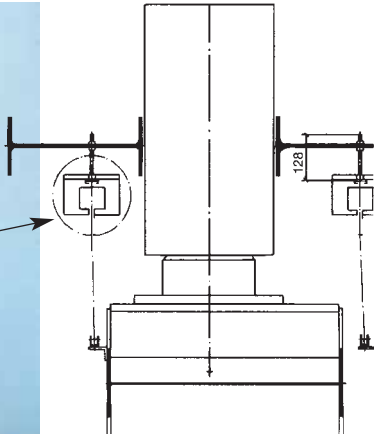

VAHLE POWERCOM®-data transmission for Lufthansa hangar gates, Hamburg.



APPLICATIONS

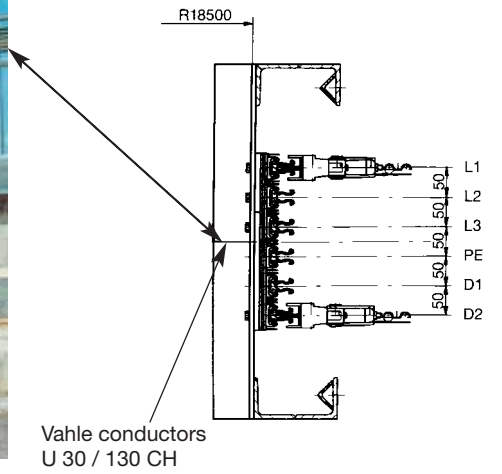

VAHLE POWERCOM®-data transmission for an asphalt testing installation

Track Layout

