

EAS[®]-Compact[®]

Backlash-free Torque Limiting Clutches

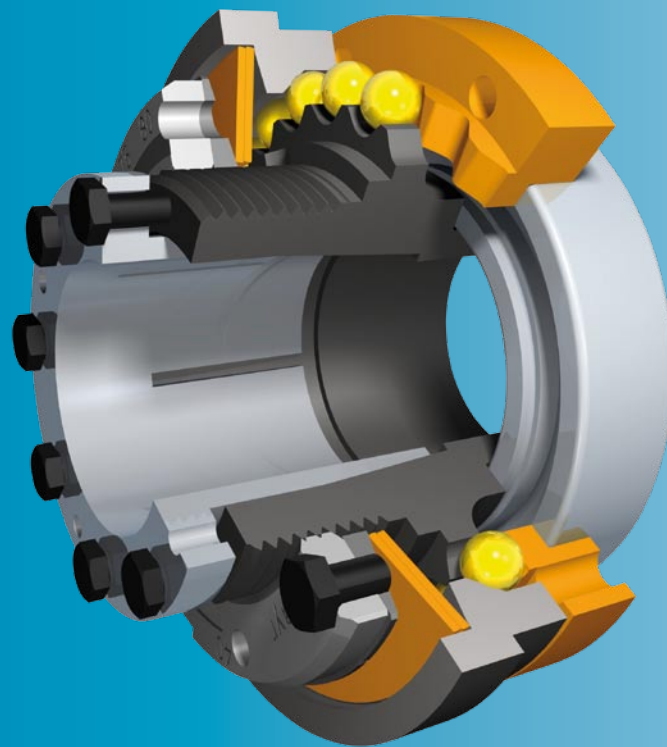

- *Instant separation on overload*
- *Permanent backlash-free torque transmission*
- *Readable torque adjustment*
- *Synchronous, ratchetting and overload designs*

www.mayr.com

K.490.V11.GB

mayr[®]
your reliable partner

mayr[®] -your reliable partner

What is your definition of reliability?

We define reliability as the highest product quality and competent service from the initial contact right up to the after-sale service

- Largest variety in selection of standard products
- Market leader's competence arising from decades of experience in the development, production and application of power transmission products
- Optimum product selection due to our expertise in design and calculation
- Reliable component dimensioning
- Intelligent platform (modular construction)
- High flexibility for individual requests and customer-tailored solutions
- Quality-inspected suppliers
- Modern, highly robust materials
- In-house production
- 100% quality control
- Certified according to DIN EN ISO 9001:2000
- Personal supervision from the first contact right up to the after-sale service
- Worldwide local service network
- CAD-files available online to save time and costs during construction
- 24-hour delivery service for preferred products
- Short delivery times and on-time delivery
- Unlimited replacement part availability worldwide



A Worldwide Presence

Our Sales and Service network is constantly expanding. We guarantee you and your customers local representation almost all over the world. With eight branch firms in France, Switzerland, Italy, England, Poland, the USA, Singapore and China as well as around 30 representatives and eight subsidiaries in Germany, we provide local service for our customers in all important industrial areas.



Total Quality Management

Product Quality

Every delivery which leaves our firm has been subjected to a careful quality inspection, meaning that you are able to rely 100 % on *mayr*® products. If required, we pre-adjust our clutches and brakes accurately to the requested values and confirm the product characteristics with an Inspection Report.

Quality Management

mayr® uses the term quality to describe its products and services. Certification of our quality management confirms the quality-consciousness of our colleagues at every level of the company.

Our integrated management system is certified according to **DIN EN ISO 9001:2000 (Quality)** and **DIN EN ISO 14001 (Environment)** and complies with the **OHSAS 18001/OHRIS (Occupational Health and Safety)** demands.



Individual and Flexible Logistics

Flexible and optimally qualified colleagues ensure that your order is delivered according to schedule and with the most appropriate delivery method. We take into account your individual packaging and dispatch regulations as a matter of course. Our modern high rack warehouse has a permanently available stock of our wide standard product selection.

And if you are really in a hurry, simply use our uniquely-quick basic product delivery service!

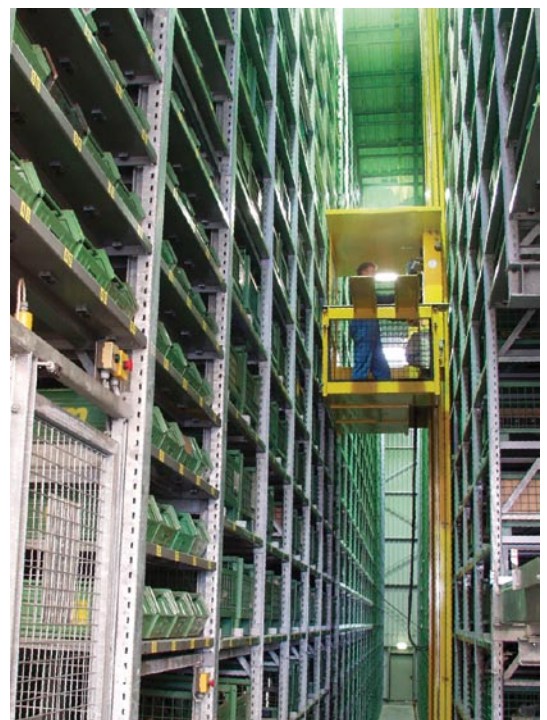

EAS®-Compact® - the economically viable protection for machines

Function

If the set limit torque is exceeded, the clutch disengages. The torque drops immediately. A mounted limit switch registers the disengagement movement and switches off the drive. The limit switch signal can also be used for further control functions.

After the malfunction has been rectified, the EAS®-Compact® ratchetting clutches and the EAS®-Compact® synchronous clutches automatically re-engage (for a detailed description of the re-engagement behaviour, see page 5). EAS®-Compact® overload clutches separate the input and the output side completely and remain in this state until they are intentionally re-engaged by hand or via a suitable device. A detailed description of the overload clutches starts on page 26.



The EAS®-Compact® matrix for success

Product characteristics	Your advantages	Your benefits
Backlash-free torque transmission	Long lifetime, low wear	Lowest maintenance effort
Safe, readable torque adjustment	Simple installation and operation	Time-saving during initial operation
High performance density	Low mass moment of inertia, compact construction	High machine dynamic
Convenient torque course in the drive line on overload	Optimised dimensioning	Effective and efficient machine construction

EAS®-Compact® – the backlash-free principle

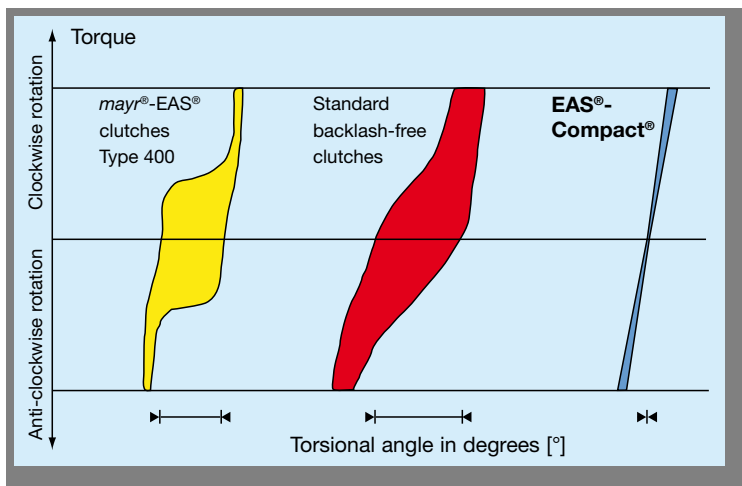

Backlash means:

- The torsional angle between the input and output of the clutch
- Also known as “torsional backlash”
- Not to be confused with the transmission backlash from the shaft onto the hub
- At mayr®, backlash-free means: backlash → 0 (see diagram)



According to German notation, decimal points in this catalogue are represented with a comma (e.g. 0,5 instead of 0.5).

**EAS®-Compact®/EAS®-NC
Ratchetting clutch**

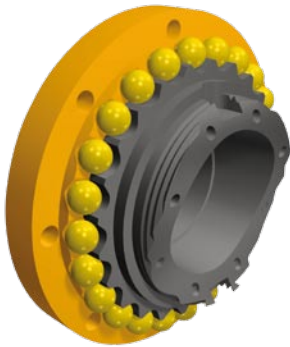

- When the set limit torque is reached, the clutch disengages; the torque drops immediately.
- The clutch ratchets.
- After the cause of overload has been removed, the clutch automatically re-engages into the next of the series of ball detents.
- The clutch is ready for operation again.

**EAS®-Compact®/EAS®-NC
Synchronous clutch**

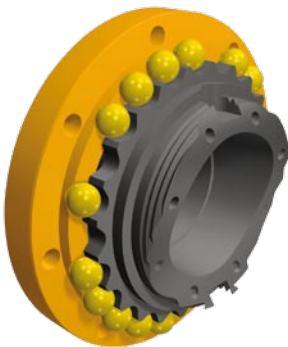

- When the set limit torque is reached, the clutch disengages; the torque drops immediately.
- After the cause of overload has been removed, the clutch re-engages automatically after 360 angular degrees. Other cycle sequences, for example 180 degrees, are also available.
- The clutch is ready for operation again.

EAS®-Compact® overload clutch

If overload occurs, the EAS®-Compact® overload clutches separate the input and output almost residual torque-free. Therefore, they are the ideal protective element for fast-running drives and high mass moments of inertia.

A detailed description starts on **page 26**.

Contents

	Page
EAS®-Compact® ratchetting clutches	
EAS®-Compact® synchronous clutches	
<i>Torque range: 5 to 1.500 Nm</i>	
Description	5
Summary of structural designs	6
Data sheets	
• EAS®-Compact® short hub	8
• EAS®-Compact® double bearing design	10
• EAS®-Compact® long protruding hub	12
• EAS®-Compact® with steel bellows coupling	14
• EAS®-Compact® torsionally rigid	16
• EAS®-Compact® lastic backlash-free	18
 <i>For small torques:</i>	
EAS®-NC ratchetting clutches	
EAS®-NC synchronous clutches	
<i>Torque range: 0,65 to 15 Nm</i>	
Data sheets:	
• EAS®-NC short hub	20
• EAS®-NC long protruding hub	20
• EAS®-NC double bearing design	22
• EAS®-NC with steel bellows coupling	24
 EAS®-Compact® overload clutches	
<i>Torque range: 5 to 3.000 Nm</i>	
Description	26
Summary of structural designs	27
Data sheets	
• EAS®-Compact® overload short hub	28
• EAS®-Compact® overload long protruding hub	30
• EAS®-Compact® overload torsionally rigid, Sizes 01 to 3	32
• EAS®-Compact® overload torsionally rigid, Sizes 4 and 5	34
• EAS®-Compact® overload lastic backlash-free	36
• EAS®-Compact® overload lastic	40
 EAS®-Compact® Options	42
Technical Explanations	44
Frictionally Locking Torque Transmission	50
Limit Switch	51
Installation Examples	54

Summary of structural designs EAS®-Compact®

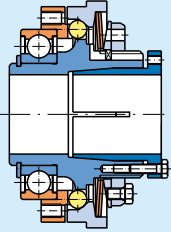
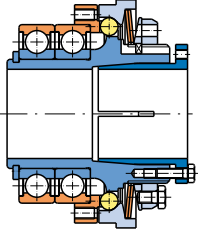
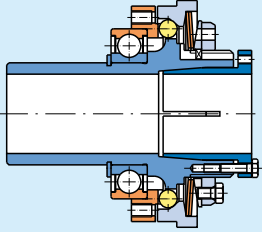
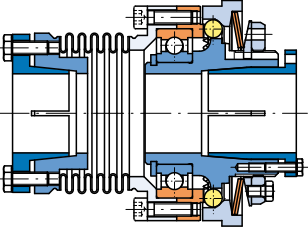
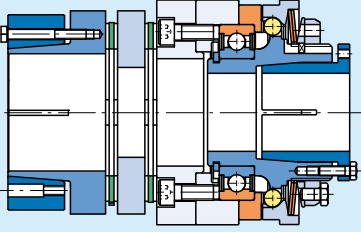
<p>EAS®-Compact® short hub</p> 	<p>Torque: 5 to 1.500 Nm</p> <p>Sizes 01 to 4 Type 490.____0</p> <p>Also available in rustproof design!</p>	<ul style="list-style-type: none"> Flange clutch for direct installation of the drive element with the resulting radial force approximately in the bearing centre See installation example, Fig. 1, page 54 <p>With cone bushing Type 490._1_.0 With keyway Type 490._2_.0</p> <p style="text-align: right;">Page 8</p>
<p>EAS®-Compact® double bearing design</p> 	<p>Torque: 5 to 1.500 Nm</p> <p>Sizes 01 to 4 Type 490.____2</p>	<ul style="list-style-type: none"> Flange clutch with a stable, double bearing for the drive element <p>With cone bushing Type 490._1_.2 With keyway Type 490._2_.2</p> <p style="text-align: right;">Page 10</p>
<p>EAS®-Compact® long protruding hub</p> 	<p>Torque: 5 to 1.500 Nm</p> <p>Sizes 01 to 4 Type 490.____1</p>	<ul style="list-style-type: none"> Flange clutch for very wide drive elements or elements with a very small diameter Suitable bearings for the drive element are ball bearings, needle bearings or plain bearings. See installation example, Fig. 2, page 54 <p>With cone bushing Type 490._1_.1 With keyway Type 490._2_.1</p> <p style="text-align: right;">Page 12</p>
<p>EAS®-Compact® with steel bellows coupling</p> 	<p>Torque: 5 to 350 Nm</p> <p>Sizes 01 to 3 Type 493.____0</p>	<ul style="list-style-type: none"> Double shaft design with a torsionally rigid steel bellows coupling Compensation for axial, radial and angular misalignments See installation example, Fig. 4, page 54 <p>Hub designs: EAS®-side/steel bellows-side Cone bushing/cone bushing Type 493._1_.0 Key hub/key hub Type 493._2_.0 Cone bushing/clamping hub Type 493._3_.0</p> <p style="text-align: right;">Page 14</p>
<p>EAS®-Compact® torsionally rigid</p> 	<p>Torque: 5 to 1.500 Nm</p> <p>Sizes 01 to 4 Type 496.____0</p>	<ul style="list-style-type: none"> Double shaft design with a robust disk pack coupling Compensation for axial, radial and angular misalignments High torsional rigidity <p>Hub designs: EAS®-side/torsionally rigid side Cone bushing/shrink disk hub Type 496._1_.0 Key hub/clamping hub Type 496._2_.0 Key hub/key hub Type 496._2_.0</p> <p style="text-align: right;">Page 16</p>

Summary of structural designs EAS®-Compact®

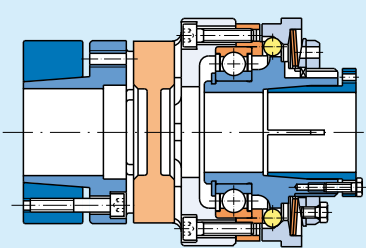
<p>EAS®-Compact® lastic backlash-free</p> 	<p>Torque: 5 to 1.200 Nm</p> <p>Sizes 01 to 4 Type 494.____</p>	<ul style="list-style-type: none"> • Double shaft design with a flexible, backlash-free coupling • Compensation for axial, radial and angular misalignments • High damping characteristics <p>See installation example, Fig. 3, page 54</p> <p>Hub designs: <u>EAS®-side/flexible side</u> Cone bushing/clamping hub Type 494._0_._ Cone bushing/shrink disk hub Type 494._1_._ Key hub/key hub Type 494._2_._</p> <p style="text-align: right;">Page 18</p>
--	---	--

Summary of structural designs EAS®-NC miniature clutch

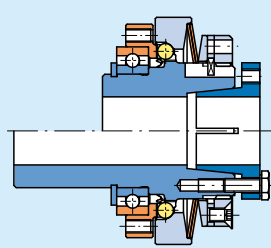
<p>EAS®-NC short hub EAS®-NC long protruding hub</p> 	<p>Torque: 0,65 to 15 Nm</p> <p>Sizes 03 and 02 Type 450.____</p>	<p>EAS®-NC short hub</p> <ul style="list-style-type: none"> • Flange clutch for direct installation of drive elements with the resulting radial force approximately in the bearing centre <p>With cone bushing Type 450._1_._0 With keyway Type 450._2_._0</p> <p>EAS®-NC long protruding hub</p> <ul style="list-style-type: none"> • Flange clutch for very wide drive elements or elements with a very small diameter <p>With cone bushing Type 450._1_._1 With keyway Type 450._2_._1</p> <p style="text-align: right;">Page 20</p>
---	---	--

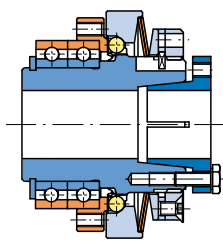
<p>EAS®-NC double bearing design</p> 	<p>Torque: 0,65 to 15 Nm</p> <p>Sizes 03 and 02 Type 450.____2</p>	<ul style="list-style-type: none"> • Flange clutch with a stable, double bearing for the drive element <p>With cone bushing Type 450._1_._2 With keyway Type 450._2_._2</p> <p style="text-align: right;">Page 22</p>
---	--	--

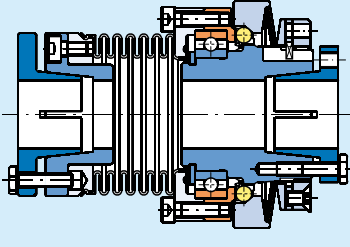
<p>EAS®-NC with steel bellows coupling</p> 	<p>Torque: 0,65 to 15 Nm</p> <p>Sizes 03 and 02 Type 453.____0</p>	<ul style="list-style-type: none"> • Double shaft design with a torsionally rigid steel bellows coupling • Compensation for axial, radial and angular misalignments <p>Hub designs: <u>EAS®-side/steel bellows-side</u> Cone bushing/cone bushing Type 453._1_._0 Key hub/key hub Type 453._2_._0</p> <p style="text-align: right;">Page 24</p>
---	--	--

EAS®-Compact® short hub with cone bushing

Type 490._1_.0
 Sizes 01 to 4

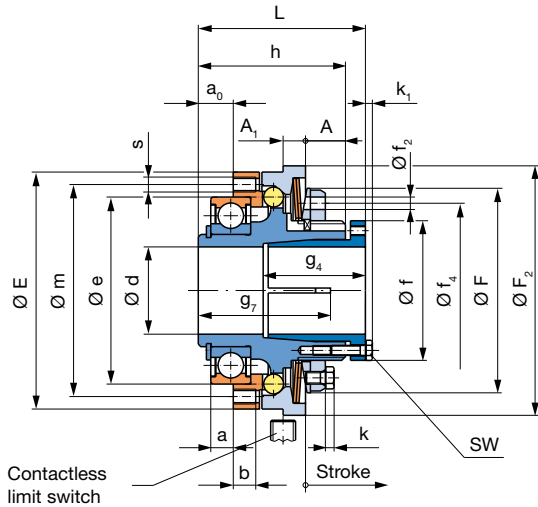

For information on rustproof designs, please order catalogue!

EAS®-Compact® short hub with keyway

Type 490._2_.0
 Sizes 01 to 4

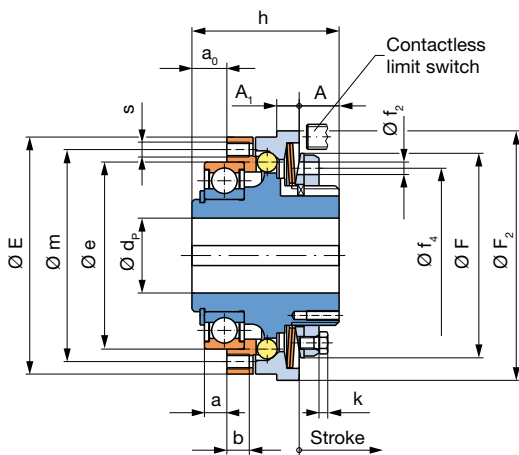

For information on rustproof designs, please order catalogue!

Order Number

		with cone bushing with keyway	1 2	0 5	Ratchetting clutch ³⁾ Synchronous clutch	Torque adjustment value (Optional)
_ / 4 9 0 . _ _ _ . 0 / _ / _ / _ / _						
Sizes	Torque range ¹⁾				Hub bore	With limit switch
01	medium		5		Ø d ^{H7}	see
to	high		6		Ø d _P ^{H7}	pages 51-53
4	very high		7			(Option)
	maximum ²⁾		8			Radial torque adjustment
						see page 42 (Option)

Example: Order number 1 / 490.620.0 / 25 / 60 / limit switch 055.002.5 / radial adjustment

1) See Technical Data, limit torque for overload M_G

2) Max. torque range only available as synchronous clutch, speed < 250 rpm

3) Standard ratchetting division is 15°; other ratchetting divisions optionally available (45°/60°/90°/120°/180°/...)

Technical Data				Size ¹⁾					
				01	0	1	2	3	4
Limit torques for overload ^{1) 2)}	Type 490.5_..0	M _G	[Nm]	5 – 12,5	10 – 25	20 – 50	40 – 100	70 – 175	120 – 300
	Type 490.6_..0	M _G	[Nm]	10 – 25	20 – 50	40 – 100	80 – 200	140 – 350	240 – 600
	Type 490.7_..0	M _G	[Nm]	20 – 50	40 – 100	80 – 200	160 – 400	280 – 700	480 – 1200
	Type 490.8_ 5.0 ¹¹⁾	M _G	[Nm]	25 – 62,5	50 – 125	100 – 250	200 – 500	350 – 875	600 – 1500
Max. speed	n _{max}		[rpm]	4000	3000	2500	2000	1200	800
Thrust washer stroke on overload			[mm]	1,2	1,5	1,8	2,0	2,2	2,5

Mass moments of inertia and weights				Size					
				01	0	1	2	3	4
Hub-side	Type 490._1_..0	I	[10 ⁻³ kgm ²]	0,211	0,531	1,388	2,846	6,858	29,432
	Type 490._2_..0	I	[10 ⁻³ kgm ²]	0,205	0,505	1,302	2,630	6,329	28,443
Pressure flange-side	Type 490._1_..0	I	[10 ⁻³ kgm ²]	0,093	0,234	0,643	1,306	2,649	6,690
	Type 490._2_..0	I	[10 ⁻³ kgm ²]	0,093	0,234	0,643	1,306	2,649	6,690
Weights	Type 490._1_..0	m	[kg]	0,68	1,14	1,98	2,88	4,59	10,63
	Type 490._2_..0	m	[kg]	0,63	1,02	1,75	2,55	4,07	10,06

Clamping screws and screw-on bores				Size					
				01	0	1	2	3	4
Clamping screws in cone bushing	Number, dimensions	M	[mm]	6 x M4	6 x M4	8 x M4	8 x M5	8 x M6	8 x M8
	Wrench opening	SW	[mm]	7	7	7	8	10	13
	Tightening torque	T _A	[Nm]	4	4	4	8	12	25
Screw-on bores in pressure flange	Number, dimensions	s	[mm]	8 x M4	8 x M5	8 x M6	8 x M6	8 x M8	8 x M10
	For clutch operation from "torque range high (Type 490.6_..0)" and above, screws quality class 12.9 must be used to secure the drive element.								

Dimensions [mm]	Size						
	01	0	1	2	3	4	
A	12	13,5	16	17	20,5	46	
A ₁	7	8	9	10	12	16	
a ⁵⁾	5	7	9	10	10	12	
a ₀	8	11	14	16	18	21	
b	6	7	9	10	12	15	
E	65	80	95	110	130	166	
e _{h5} ⁶⁾	47	62	75	90	100	130	
F	61,5	67	82	97	117	150	
F ₂	70	85	100	115	135	166	
f	38	44	56	70	84	100	
f ₂	5	5	5	6	7	-	
f ₄	50	55	70	84	100	-	
Min. shaft length	g ₄	34	39	42	48	53	93
	g ₇	31	36	48	49	62	78
h	40	48	59	64	75	115	
k	2,8	2,8	3,5	4,0	4,0	-	
k ₁	2,8	2,8	2,8	3,5	4,0	5,3	
L ⁷⁾	47	56	67	73	86	130	
m	56	71	85	100	116	150	

Bores [mm]	Size						
	01	0	1	2	3	4	
d ^{2) 3) 4)}	d _{min}	10	15	22	32	35	40
	d _{max}	20	25	35	45	55	65
d _P ^{2) 10)}	d _{P min} ⁸⁾	12	15	22	28	32	40
	d _{P max} ⁹⁾	20	25	30	40	50	65

We reserve the right to make dimensional and constructional alterations.

- 1) Further sizes for smaller and larger torques available on request
- 2) Please observe the shaft load in max. torque range.
- 3) Shaft tolerance up to $\varnothing 38_{h6}$ over $\varnothing 38_{h8}$
- 4) Transmittable torques with smaller bores available on request
- 5) Mounting tolerance + 0,1
- 6) Tolerance user-side H7
- 7) Dimensions in untightened condition (shorter in tightened condition)
- 8) Smaller bores for low torques available on request
- 9) Larger bores available on request
- 10) The position of the keyway to the mounting bore "s" in the pressure flange is not defined. Defined position available on request
- 11) Maximum speed: 250 rpm

EAS®-Compact® double bearing design with cone bushing

Type 490._1_.2
 Sizes 01 to 4

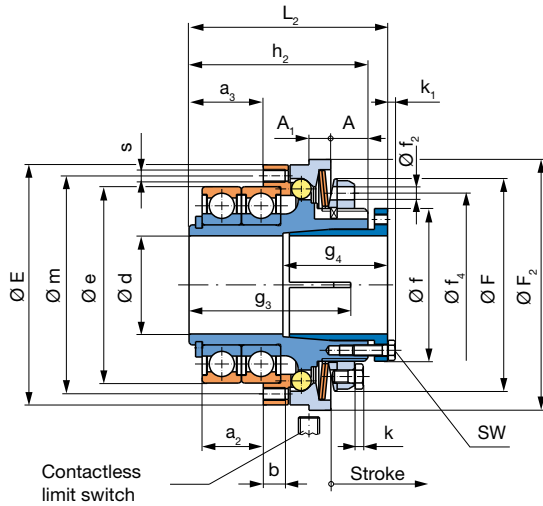

EAS®-Compact® double bearing design with keyway

Type 490._2_.2
 Sizes 01 to 4

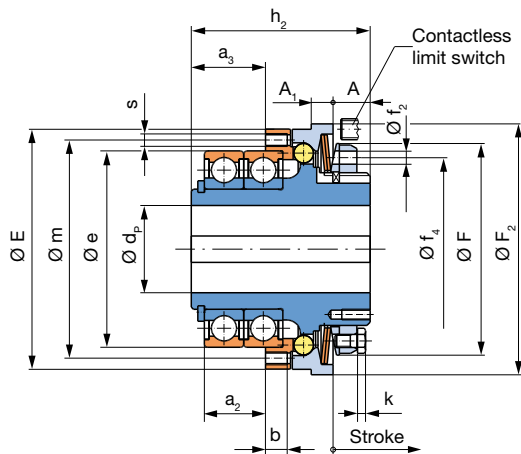

Order Number

	with cone bushing with keyway	1 2	0 5	Ratchetting clutch ³⁾ Synchronous clutch	Torque adjustment value (Optional)	With limit switch see pages 51-53 (Option)
▾ ▾ ▾ ▾ ▾ ▾ ▾						
_ / 4 9 0 . _ _ _ . 2 / _ / _ / _ / _						
▲ ▲ ▲ ▲ ▲ ▲ ▲						
Sizes	Torque range ¹⁾		2-bearing design	2	Hub bore Ø d ^{H7} Ø d _p ^{H7}	Radial torque adjustment see page 42 (Option)
01 to 4	medium high very high maximum ²⁾	5 6 7 8				

Example: Order number 1 / 490.610.2 / 25 / 60 / limit switch 055.002.5 / radial adjustment

1) See Technical Data, limit torque for overload M_G

2) Max. torque range only available as synchronous clutch, speed < 250 rpm

3) Standard ratchetting division is 15°; other ratchetting divisions optionally available (45°/60°/90°/120°/180°/...)

Technical Data				Size ¹⁾					
				01	0	1	2	3	4
Limit torques for overload ^{1) 2)}	Type 490.5_..2	M _G	[Nm]	5 – 12,5	10 – 25	20 – 50	40 – 100	70 – 175	120 – 300
	Type 490.6_..2	M _G	[Nm]	10 – 25	20 – 50	40 – 100	80 – 200	140 – 350	240 – 600
	Type 490.7_..2	M _G	[Nm]	20 – 50	40 – 100	80 – 200	160 – 400	280 – 700	480 – 1200
	Type 490.8_ 5.2 ¹¹⁾	M _G	[Nm]	25 – 62,5	50 – 125	100 – 250	200 – 500	350 – 875	600 – 1500
Max. speed	n _{max}	[rpm]		4000	3000	2500	2000	1200	800
Thrust washer stroke on overload		[mm]		1,2	1,5	1,8	2,0	2,2	2,5

Mass moments of inertia and weights				Size					
				01	0	1	2	3	4
Hub-side	Type 490._1_..2	I	[10 ⁻³ kgm ²]	0,215	0,552	1,450	2,998	7,081	30,990
	Type 490._2_..2	I	[10 ⁻³ kgm ²]	0,209	0,526	1,364	2,782	6,552	30,000
Pressure flange-side	Type 490._1_..2	I	[10 ⁻³ kgm ²]	0,100	0,273	0,799	1,675	3,162	8,570
	Type 490._2_..2	I	[10 ⁻³ kgm ²]	0,100	0,273	0,799	1,675	3,162	8,570
Weights	Type 490._1_..2	m	[kg]	0,79	1,35	2,35	3,45	5,27	11,96
	Type 490._2_..2	m	[kg]	0,74	1,23	2,12	3,12	4,75	11,35

Clamping screws and screw-on bores				Size					
				01	0	1	2	3	4
Clamping screws in cone bushing	Number, dimensions	M	[mm]	6 x M4	6 x M4	8 x M4	8 x M5	8 x M6	8 x M8
	Wrench opening	SW	[mm]	7	7	7	8	10	13
	Tightening torque	T _A	[Nm]	4	4	4	8	12	25
Screw-on bores in pressure flange	Number, dimensions	s	[mm]	8 x M4	8 x M5	8 x M6	8 x M6	8 x M8	8 x M10
	For clutch operation from "torque range high (Type 490.6_..2)" and above, screws quality class 12.9 must be used to secure the drive element.								

Dimensions [mm]	Size						
	01	0	1	2	3	4	
A	12	13,5	16	17	20,5	46	
A ₁	7	8	9	10	12	16	
a ₂ ⁵⁾	14	19	25	28	28	34	
a ₃	17	23	30	34	36	43	
b	6	7	9	10	12	15	
E	65	80	95	110	130	166	
e _{h5} ⁶⁾	47	62	75	90	100	130	
F	61,5	67	82	97	117	150	
F ₂	70	85	100	115	135	166	
f	38	44	56	70	84	100	
f ₂	5	5	5	6	7	-	
f ₄	50	55	70	84	100	-	
Min. shaft length	g ₃	40	48	63	67	80	100
	g ₄	34	39	42	48	53	93
h ₂	49	60	75	82	93	137	
k	2,8	2,8	3,5	4,0	4,0	-	
k ₁	2,8	2,8	2,8	3,5	4,0	5,3	
L ₂ ⁷⁾	56	68	83	91	104	152	
m	56	71	85	100	116	150	

Bores [mm]		Size					
		01	0	1	2	3	4
d ^{2) 3) 4)}	d _{min}	10	15	22	32	35	40
	d _{max}	20	25	35	45	55	65
d _P ^{2) 10)}	d _{P min} ⁸⁾	12	15	22	28	32	40
	d _{P max} ⁹⁾	20	25	30	40	50	65

We reserve the right to make dimensional and constructional alterations.

- 1) Further sizes for smaller and larger torques available on request
- 2) Please observe the shaft load in max. torque range.
- 3) Shaft tolerance up to Ø 38_{h6'} over Ø 38_{h8}
- 4) Transmittable torques with smaller bores available on request
- 5) Mounting tolerance + 0,1
- 6) Tolerance user-side H7
- 7) Dimensions in untightened condition (shorter in tightened condition)
- 8) Smaller bores for low torques available on request
- 9) Larger bores available on request
- 10) The position of the keyway to the mounting bore "s" in the pressure flange is not defined. Defined position available on request
- 11) Maximum speed: 250 rpm

EAS®-Compact® long protruding hub with cone bushing

Type 490._1_.1
 Sizes 01 to 4

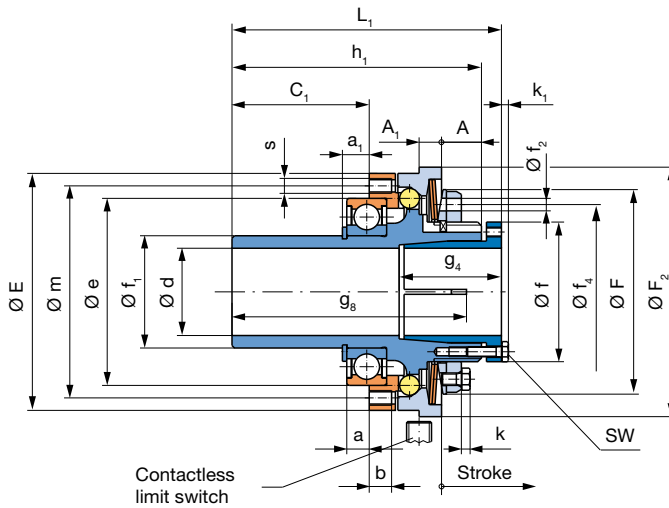

EAS®-Compact® long protruding hub with keyway

Type 490._2_.1
 Sizes 01 to 4

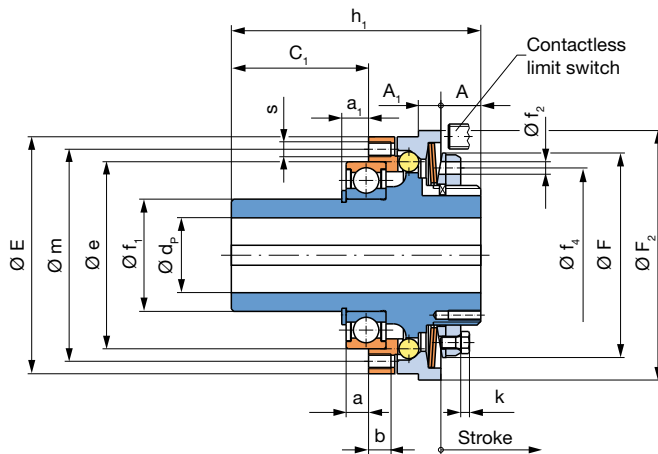

Order Number

with cone bushing		1	0	Ratchetting clutch ³⁾	Torque adjustment value (Optional)	With limit switch see pages 51-53 (Option)
with keyway		2	5	Synchronous clutch		
▾ ▾ ▾ ▾ ▾ ▾ ▾						
_ / 4 9 0 . _ _ _ . 1 / _ / _ / _ / _						
▲ ▲ ▲ ▲ ▲ ▲ ▲						
Sizes 01 to 4	Torque range ¹⁾	5	long protruding hub	1	Hub bore Ø d ^{H7} Ø d _p ^{H7}	Radial torque adjustment see page 42 (Option)
	medium	6				
	high	7				
	very high	8				
	maximum ²⁾					

Example: Order number 1 / 490.610.1 / 25 / 60 / limit switch 055.002.5 / radial adjustment

1) See Technical Data, limit torque for overload M_G

2) Max. torque range only available as synchronous clutch, speed < 250 rpm

3) Standard ratchetting division is 15°; other ratchetting divisions optionally available (45°/60°/90°/120°/180°/...)

Technical Data				Size ¹⁾					
				01	0	1	2	3	4
Limit torques for overload ¹⁾²⁾	Type 490.5_..1	M _G	[Nm]	5 – 12,5	10 – 25	20 – 50	40 – 100	70 – 175	120 – 300
	Type 490.6_..1	M _G	[Nm]	10 – 25	20 – 50	40 – 100	80 – 200	140 – 350	240 – 600
	Type 490.7_..1	M _G	[Nm]	20 – 50	40 – 100	80 – 200	160 – 400	280 – 700	480 – 1200
	Type 490.8_ 5.1 ¹¹⁾	M _G	[Nm]	25 – 62,5	50 – 125	100 – 250	200 – 500	350 – 875	600 – 1500
Max. speed	n _{max}	[rpm]		4000	3000	2500	2000	1200	800
Thrust washer stroke on overload		[mm]		1,2	1,5	1,8	2,0	2,2	2,5

Mass moments of inertia and weights				Size					
				01	0	1	2	3	4
Hub-side	Type 490_1_..1	I	[10 ⁻³ kgm ²]	0,225	0,588	1,491	3,105	7,350	30,890
	Type 490_2_..1	I	[10 ⁻³ kgm ²]	0,219	0,562	1,405	2,889	6,851	29,900
Pressure flange-side	Type 490_1_..1	I	[10 ⁻³ kgm ²]	0,093	0,234	0,643	1,306	2,649	6,690
	Type 490_2_..1	I	[10 ⁻³ kgm ²]	0,093	0,234	0,643	1,306	2,649	6,690
Weights	Type 490_1_..1	m	[kg]	0,78	1,36	2,26	3,34	5,18	11,65
	Type 490_2_..1	m	[kg]	0,73	1,24	2,04	3,00	4,66	11,04

Clamping screws and screw-on bores				Size					
				01	0	1	2	3	4
Clamping screws in cone bushing	Number, dimensions	M	[mm]	6 x M4	6 x M4	8 x M4	8 x M5	8 x M6	8 x M8
	Wrench opening	SW	[mm]	7	7	7	8	10	13
	Tightening torque	T _A	[Nm]	4	4	4	8	12	25
Screw-on bores in pressure flange	Number, dimensions	s	[mm]	8 x M4	8 x M5	8 x M6	8 x M6	8 x M8	8 x M10
	For clutch operation from "torque range high (Type 490.6_..1)" and above, screws quality class 12.9 must be used to secure the drive element.								

Dimensions [mm]	Size						
	01	0	1	2	3	4	
A	12	13,5	16	17	20,5	46	
A ₁	7	8	9	10	12	16	
a ⁵⁾	5	7	9	10	10	12	
a ₁	6,5	8,75	11,5	13	14	16	
b	6	7	9	10	12	15	
C ₁	33	43	55	67	73	76	
E	65	80	95	110	130	166	
e _{h5} ⁶⁾	47	62	75	90	100	130	
F	61,5	67	82	97	117	150	
F ₂	70	85	100	115	135	166	
f	38	44	56	70	84	100	
f _{1h6}	30	40	45	55	65	85	
f ₂	5	5	5	6	7	-	
f ₄	50	55	70	84	100	-	
Min. shaft length	g ₄	34	39	42	48	53	93
	g ₈	56	68	89	100	117	133
h ₁	65	80	100	115	130	170	
k	2,8	2,8	3,5	4,0	4,0	-	
k ₁	2,8	2,8	2,8	3,5	4,0	5,3	
L ₁ ⁷⁾	72	88	108	124	141	185	
m	56	71	85	100	116	150	

Bores [mm]	Size						
	01	0	1	2	3	4	
d ²⁾³⁾⁴⁾	d _{min}	10	15	22	32	35	40
	d _{max}	20	25	35	45	55	65
d _P ²⁾¹⁰⁾	d _{P min} ⁸⁾	12	15	22	28	32	40
	d _{P max} ⁹⁾	20	25	30	40	50	65

We reserve the right to make dimensional and constructional alterations.

- 1) Further sizes for smaller and larger torques available on request
- 2) Please observe the shaft load in max. torque range.
- 3) Shaft tolerance up to Ø 38_{h6} over Ø 38_{h8}
- 4) Transmittable torques with smaller bores available on request
- 5) Mounting tolerance + 0,1
- 6) Tolerance user-side H7
- 7) Dimensions in untightened condition (shorter in tightened condition)
- 8) Smaller bores for low torques available on request
- 9) Larger bores available on request
- 10) The position of the keyway to the mounting bore "s" in the pressure flange is not defined. Defined position available on request
- 11) Maximum speed: 250 rpm

Technical Data				Size ¹⁾				
				01	0	1	2	3
Limit torques for overload ¹⁾	Type 493.5_..0	M _G	[Nm]	5 – 12,5	10 – 25	20 – 50	40 – 100	70 – 175
	Type 493.6_..0	M _G	[Nm]	10 – 25	20 – 50	40 – 100	80 – 200	140 – 350
Max. speed		n _{max}	[rpm]	4000	3000	2500	2000	1200
Thrust washer stroke on overload			[mm]	1,2	1,5	1,8	2,0	2,2
Nominal torques, steel bellows coupling		T _{KN}	[Nm]	50	100	200	350	600
Permitted misalignments	axial	ΔK _a	[mm]	0,4	0,6	0,8	1,0	1,0
	radial	ΔK _r	[mm]	0,15	0,15	0,20	0,25	0,30
	angular	ΔK _w	[°]	2	2	2	2	2

Mass moments of inertia and weights				Size				
				01	0	1	2	3
EAS®-hub-side	Type 493.1_..0	I	[10 ⁻³ kgm ²]	0,211	0,531	1,388	2,846	6,858
	Type 493.2_..0	I	[10 ⁻³ kgm ²]	0,205	0,505	1,302	2,630	6,359
	Type 493.3_..0	I	[10 ⁻³ kgm ²]	0,211	0,531	1,388	2,846	6,858
Steel bellows-side	Type 493.1_..0	I	[10 ⁻³ kgm ²]	0,269	0,753	1,764	3,602	7,789
	Type 493.2_..0	I	[10 ⁻³ kgm ²]	0,249	0,690	1,546	3,018	6,818
	Type 493.3_..0	I	[10 ⁻³ kgm ²]	0,286	0,789	1,772	3,773	8,087
Weights	Type 493.1_..0	m	[kg]	1,09	1,88	3,08	4,60	7,19
	Type 493.2_..0	m	[kg]	1,04	1,76	2,85	4,27	6,90
	Type 493.3_..0	m	[kg]	1,22	1,91	3,10	4,65	7,12

Clamping screws				Size				
				01	0	1	2	3
In cone bushing EAS®-side	Number, dimensions	M	[mm]	6 x M4	6 x M4	8 x M4	8 x M5	8 x M6
	Wrench opening	SW	[mm]	7	7	7	8	10
	Tightening torque	T _A	[Nm]	4	4	4	8	12
In cone bushing steel bellows-side	Number, dimensions	M ₁	[mm]	4 x M4	6 x M5	6 x M6	6 x M8	6 x M8
	Wrench opening	SW ₁	[mm]	7	8	10	13	13
	Tightening torque	T _A	[Nm]	3	5	9,5	17	17
In clamping hub steel bellows-side	Number, dimensions	M ₃	[mm]	1 x M5	1 x M6	1 x M6	1 x M8	1 x M10
	Wrench opening	SW ₃	[mm]	4	5	5	6	8
	Tightening torque	T _A	[Nm]	10	18	18	43	87

Dimensions [mm]		Size				
		01	0	1	2	3
A		12	13,5	16	17	20,5
A ₁		7	8	9	10	12
C ₃		45	53	64	70	81
D ₁		47	60	70	81	98
D ₂		47	60	71	81	98
D ₃		50	60	71	82	98
E		65	80	95	110	130
F		61,5	67	82	97	117
F ₂		70	85	100	115	135
f		38	44	56	70	84
f ₂		5	5	5	6	7
f ₄		50	55	70	84	100
Min. shaft length	g ₄	34	39	42	48	53
	g ₅	24	27	29	32	35
	l ₃	24	28	28	36	40
h		40	48	59	64	75
k		2,8	2,8	3,5	4,0	4,0
k ₁		2,8	2,8	2,8	3,5	4,0
L ⁴⁾		47	56	67	73	86
L ₁ ⁴⁾		93	109	125,5	138	164
L ₂		77,5	92	107,5	119	140,5
L ₃ ⁴⁾		102	119	133	150	177
l ₁ ⁴⁾		27,5	29	33	37	45
l ₂		25	27	29	36	44

Bores [mm]			Size				
			01	0	1	2	3
EAS®-side	d ^{2) 3)}	d _{min}	10	15	22	32	35
		d _{max}	20	25	35	45	55
	d _P	d _{P min}	12	15	22	28	32
		d _{P max}	20	25	30	40	50
Steel bellows-side	d ₁ ^{2) 3)}	d _{1 min}	9	12	15	22	32
		d _{1 max}	20	25	35	42	50
	d ₂	d _{2 min}	9	12	15	22	32
		d _{2 max}	20 ⁵⁾	25 ⁶⁾	35 ⁷⁾	42 ⁸⁾	50
	d ₃	d _{3 min}	12	15	25	30	35
		d _{3 max}	25	32	42	45	55

We reserve the right to make dimensional and constructional alterations.

- 1) Further sizes for smaller and larger torques available on request
- 2) Shaft tolerance up to Ø 38_{h6} over Ø 38_{h8}
- 3) Transmittable torques with smaller bores available on request
- 4) Dimensions in untightened condition (shorter in tightened condition)
- 5) Up to Ø 18 keyway acc. DIN 6885/1, over Ø 18 keyway acc. DIN 6885/3
- 6) Up to Ø 22 keyway acc. DIN 6885/1, over Ø 22 keyway acc. DIN 6885/3
- 7) Up to Ø 33 keyway acc. DIN 6885/1, over Ø 33 keyway acc. DIN 6885/3
- 8) Up to Ø 38 keyway acc. DIN 6885/1, over Ø 38 keyway acc. DIN 6885/3

EAS®-Compact® torsionally rigid

Type 496. . . . 0

Sizes 01 to 4

EAS®-side cone bushing

ROBA®-DS-side shrink disk hub

Type 496. 1 . 0, Sizes 01 to 4

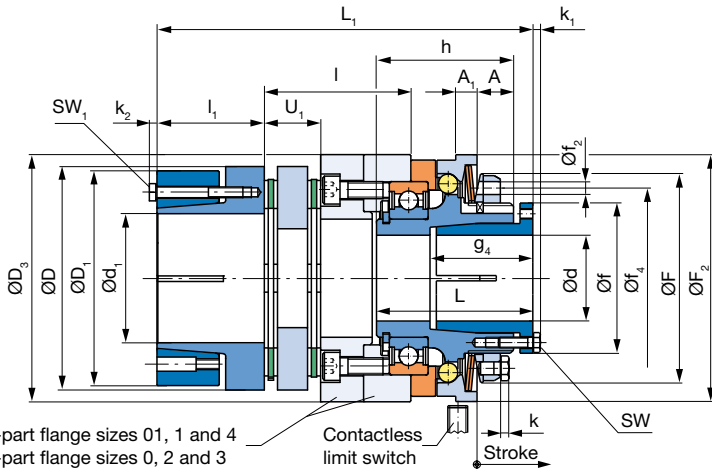

All EAS®-Compact® clutches can be combined with almost all components of the ROBA®-DS backlash-free shaft coupling. The Types shown here represent only a selection of the most established designs.

For further combination possibilities, see page 43.

We are happy to assist you in dimensioning and assembling your optimum clutch.

EAS®-side key hub

ROBA®-DS-side clamping hub with keyway

Type 496. 2 . 0, Sizes 01 and 0

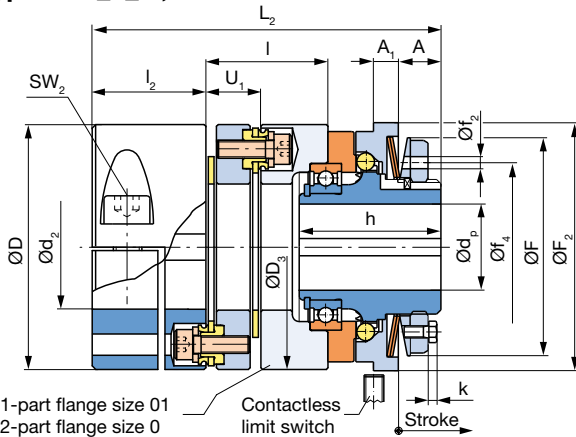

EAS®-side key hub

ROBA®-DS-side key hub

Type 496. 2 . 0, Sizes 1 to 4

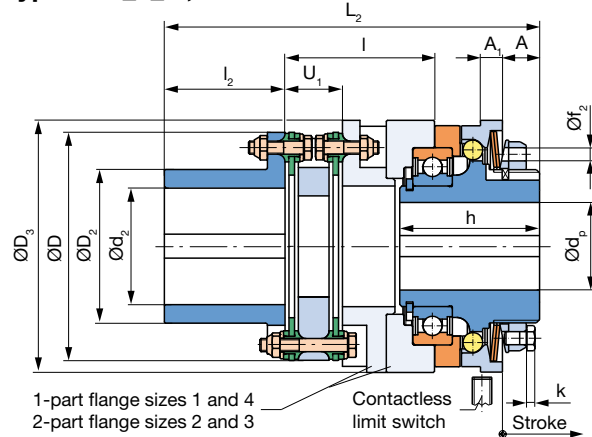

The missing dimensions (Øf₄, ØF and ØF₂) are identical to Type 496. 2 . 0

Order Number

EAS®-side Cone bushing Key hub	ROBA®-DS-side Shrink disk hub Clamping hub ⁴⁾ with keyway (sizes 01-0) / key hub (sizes 1-4)	1 2	0 5	Ratchetting clutch ³⁾ Synchronous clutch	Torque adjustment value (Optional)	With limit switch see page 51-53 (Option)
---	--	----------------------	----------------------	--	------------------------------------	---



Sizes 01 to 4	Torque range ¹⁾ medium high very high maximum ²⁾	5 6 7 8	Hub 1 bore Ø d ^{H7} Ø d _p ^{H7}	Hub 2 bore Ø d ₁ ^{H7} Ø d ₂ ^{H7}	Radial torque adjustment see page 42 (Option)
--	---	--	--	---	---

Example: Order number 1 / 496.625.0 / 22 / 25 / 60 / limit switch 055.002.5 / radial adjustment

1) See Technical Data, limit torque for overload M_G
 2) Max. torque range only available as synchronous clutch, speed < 250 rpm
 3) Standard ratchetting division is 15°; other ratchetting divisions optionally available (45°/60°/90°/120°/180°/...)
 4) Clamping hub also available without keyway (sizes 01-0)

Technical Data				Size ¹⁾					
				01	0	1	2	3	4
Limit torques for overload ¹⁾	Type 496.5__0	M_G [Nm]	5 – 12,5	10 – 25	20 – 50	40 – 100	70 – 175	120 – 300	
	Type 496.6__0	M_G [Nm]	10 – 25	20 – 50	40 – 100	80 – 200	140 – 350	240 – 600	
	Type 496.7__0	M_G [Nm]	20 – 50	40 – 100	80 – 200	160 – 400	280 – 700	480 – 1200	
	Type 496.8_5.0 ⁵⁾	M_G [Nm]	25 – 62,5	50 – 125	100 – 250	200 – 500	350 – 875	600 – 1500	
Max. speed	n_{max} [rpm]		4000	3000	2500	2000	1200	800	
Thrust washer stroke on overload	[mm]		1,2	1,5	1,8	2,0	2,2	2,5	
Nominal torques, torsionally rigid coupling	T_{KN} [Nm]		100	150	300	650	1100	1600	
Permitted misalignments	axial ⁶⁾	ΔK_a [mm]	0,9	1,1	0,8	1,1	1,3	1,5	
	radial	ΔK_r [mm]	0,20	0,20	0,20	0,25	0,30	0,30	
	angular	ΔK_w [°]	2,0	2,0	1,4	1,4	1,4	1,4	

Mass moments of inertia and weights				Size					
				01	0	1	2	3	4
EAS®-hub-side	Type 496._1_0	I [10 ⁻³ kgm ²]	0,211	0,531	1,388	2,846	6,858	29,432	
	Type 496._2_0	I [10 ⁻³ kgm ²]	0,205	0,505	1,302	2,630	6,359	28,443	
ROBA®-DS-side	Type 496._1_0	I [10 ⁻³ kgm ²]	0,849	2,395	2,915	9,543	21,443	38,996	
	Type 496._2_0	I [10 ⁻³ kgm ²]	0,709	2,086	2,417	7,815	18,215	31,480	
Weights	Type 496._1_0	m [kg]	1,63	2,95	3,80	7,04	11,45	19,16	
	Type 496._2_0	m [kg]	1,43	2,61	3,50	6,35	10,81	17,31	

Clamping screws				Size					
				01	0	1	2	3	4
In cone bushing EAS®-side	Number, dimensions	M [mm]	6 x M4	6 x M4	8 x M4	8 x M5	8 x M6	8 x M8	
	Wrench opening	SW [mm]	7	7	7	8	10	13	
	Tightening torque	T_A [Nm]	4	4	4	8	12	25	
In shrink hub ROBA®-DS-side	Number, dimensions	M_1 [mm]	4 x M5	6 x M5	6 x M5	6 x M5	6 x M6	6 x M8	
	Wrench opening	SW_1 [mm]	8	8	8	8	10	13	
	Tightening torque	T_A [Nm]	6	6	6	8,5	10	25	
In clamping hub ROBA®-DS-side	Number, dimensions	M_2 [mm]	1 x M8	1 x M8	-	-	-	-	
	Wrench opening	SW_2 [mm]	6	6	-	-	-	-	
	Tightening torque	T_A [Nm]	33	33	-	-	-	-	

Dimensions [mm]	Size					
	01	0	1	2	3	4
A	12	13,5	16	17	20,5	46
A ₁	7	8	9	10	12	16
D	69	79	77	104	123	143
D ₁	68	78	77	100	115	143
D ₂	-	-	50	70	80	100
D ₃	69	85	100	115	135	172
F	61,5	67	82	97	117	150
F ₂	70	85	100	115	135	166
f	38	44	56	70	84	100
f ₂	5	5	5	6	7	-
f ₄	50	55	70	84	100	-
Min. shaft length g ₄	34	39	42	48	53	93
h	40	48	59	64	75	115
k	2,8	2,8	3,5	4,0	4,0	-
k ₁	2,8	2,8	2,8	3,5	4,0	5,3
k ₂	3,5	3,5	3,5	3,5	4,0	5,3
L ⁴⁾	47	56	67	73	86	130
L ₁ ⁴⁾	105,3	132,8	141,2	175,2	208	237
L ₂	98,3	120,3	133,2	171,2	207	237
l	34,3	49,8	48,2	68,2	85	68
l ₁	32	37,5	40	50	55	60
l ₂	32	33,5	40	55	65	75
U ₁	15,3	15,8	21,2	26,2	34	35,2

Bores [mm]			Size					
			01	0	1	2	3	4
EAS®-side	d ²⁾	d _{min}	10	15	22	32	35	40
		d _{max}	20	25	35	45	55	65
	d _P	d _{P min}	12	15	22	28	32	40
		d _{P max}	20	25	30	40	50	65
ROBA®-DS-side	d ₁ ³⁾	d _{1 min}	19	25	25	40	45	55
		d _{1 max}	38	45	45	60	70	90
	d ₂	d _{2 min}	19	25	16	25	30	35
		d _{2 max}	35	42	32	50	55	70

We reserve the right to make dimensional and constructional alterations.

- 1) Further sizes for smaller and larger torques available on request
- 2) Shaft tolerance up to $\varnothing 38_{H8}$ over $\varnothing 38_{H8}$
- 3) Recommended shaft tolerance g_6
- 4) Dimensions in untightened condition (shorter in tightened condition)
- 5) Maximum speed: 250 rpm
- 6) Only permitted as a static or virtually static value

EAS®-Compact® lastic backlash-free

Type 494. _ _ _
 Sizes 01 to 4

EAS®-side cone bushing,
 ROBA®-ES-side clamping hub
 Type 494. 0 _ _

EAS®-side cone bushing,
 ROBA®-ES-side shrink disk hub
 Type 494. 1 _ _

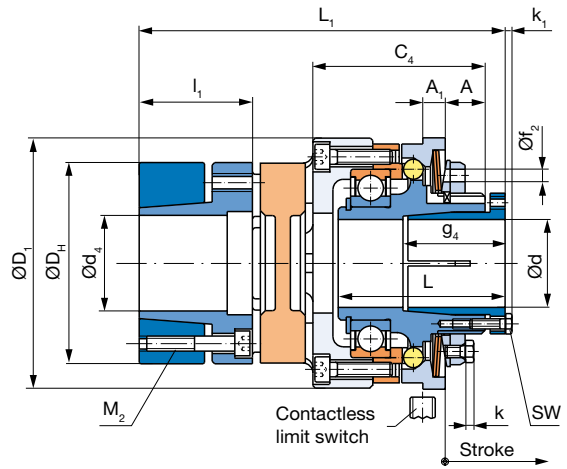
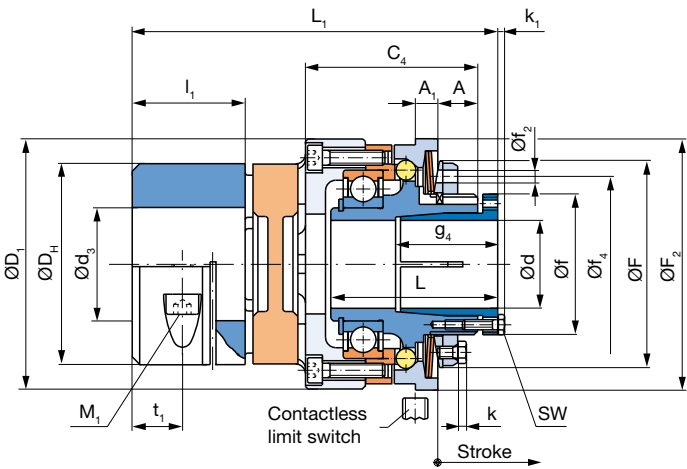

The missing dimensions (Øf, Øf₁, ØF and ØF₂) are identical to Type 494.0...

EAS®-side key hub,
 ROBA®-ES-side key hub
 Type 494. 2 _ _

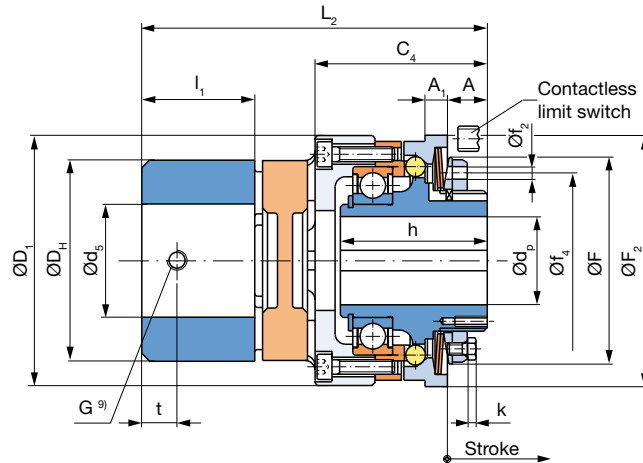

Order Number

EAS®-side Cone bushing Cone bushing Key hub	ROBA®-ES-side Clamping hub Shrink disk hub Key hub	0 1 2	0 5	Ratchetting clutch ²⁾ Synchronous clutch	Torque adjustment value (Optional)	With limit switch see page 51-53 (Option)	
_ / 4 9 4 . _ _ _ . _ / _ / _ / _ / _ / _							
Sizes 01 to 4	Torque range ¹⁾ medium high very high	5 6 7	Flexible coupling 92 Shore A 98 Shore A 64 Shore D	3 4 6	Hub 1 bore Ø d ^{H7} Ø d _p ^{H7}	Hub 2 bore Ø d ₃ ^{F7} Ø d ₄ ^{H7} Ø d ₅ ^{H7}	Radial torque adjustment see page 42 (Option)

Example: Order number 1 / 494.615.3 / 22 / 25 / 60 / limit switch 055.002.5 / radial adjustment

- 1) See Technical Data, limit torque for overload M_G
- 2) Standard ratchetting division is 15°; other ratchetting divisions optionally available (45°/60°/90°/120°/180°/...)
- 3) The transmittable torques on the flexible coupling "T_{KN}" are dependent on factors such as temperature, torsional rigidity, etc., see also coupling dimensioning ROBA®-ES catalogue K.940.V__ or contact the manufacturer. Furthermore, the transmittable torques of the flexible coupling are dependent on the bore diameter d₃ or d₄, see also Table 1 on page 50.
- 4) Shaft tolerance up to Ø 38_{h8} over Ø 38_{h8}
- 5) Transmittable torques with smaller bores available on request
- 6) Smaller bores for low torques available on request
- 7) Larger bores available on request
- 8) Shaft tolerance up to Ø 40_{j6}
- 9) Keyway 180° offset to "G"
- 10) Dimensions in untightened condition (shorter in tightened condition)

Technical Data				Größe						
				01	0	1	2	3	4	
Limit torques for overload ³⁾	Type 494.5 _ _ _	M _G	[Nm]	5 – 12,5	10 – 25	20 – 50	40 – 100	70 – 175	120 – 300	
	Type 494.6 _ _ _	M _G	[Nm]	10 – 25	20 – 50	40 – 100	80 – 200	140 – 350	240 – 600	
	Type 494.7 _ _ _	M _G	[Nm]	20 – 50	40 – 100	80 – 200	160 – 400	280 – 700	480 – 1200	
Max. speed		n _{max}	[rpm]	4000	3000	2500	2000	1200	800	
Thrust washer stroke on overload			[mm]	1,2	1,5	1,8	2,0	2,2	2,5	
Nominal and maximum torques ³⁾ , flexible coupling	92 Shore A	T _{KN} /T _{max}	[Nm]	35 / 70	95 / 190	190 / 380	265 / 530	310 / 620	- / -	
	98 Shore A	T _{KN} /T _{max}	[Nm]	60 / 120	160 / 320	325 / 650	450 / 900	525 / 1050	1040 / 2080	
	64 Shore D	T _{KN} /T _{max}	[Nm]	75 / 150	200 / 400	405 / 810	560 / 1120	655 / 1310	- / -	
Permitted misalignments	axial	ΔK _a	[mm]	1,4	1,5	1,8	2,0	2,1	2,6	
	radial	92 Shore A	ΔK _r	[mm]	0,14	0,15	0,17	0,19	0,21	-
		98 Shore A	ΔK _r	[mm]	0,10	0,11	0,12	0,14	0,16	0,18
	radial	64 Shore D	ΔK _r	[mm]	0,07	0,08	0,09	0,10	0,11	-
		92 Shore A	ΔK _w	[°]	1,0	1,0	1,0	1,0	1,0	-
	angular	98 Shore A	ΔK _w	[°]	0,9	0,9	0,9	0,9	0,9	0,9
angular	64 Shore D	ΔK _w	[°]	0,8	0,8	0,8	0,8	0,8	-	

Mass moments of inertia and weights				Size					
				01	0	1	2	3	4
EAS®-hub-side	Type 494. 0 _ _	I	[10 ⁻³ kgm ²]	0,211	0,531	1,388	2,846	6,858	29,432
	Type 494. 1 _ _	I	[10 ⁻³ kgm ²]	0,211	0,531	1,388	2,846	6,858	29,432
	Type 494. 2 _ _	I	[10 ⁻³ kgm ²]	0,205	0,505	1,302	2,630	6,359	28,443
ROBA®-ES-side	Type 494. 0 _ _	I	[10 ⁻³ kgm ²]	0,322	0,700	1,846	7,627	14,530	48,570
	Type 494. 1 _ _	I	[10 ⁻³ kgm ²]	0,381	0,833	2,280	7,475	14,167	43,038
	Type 494. 2 _ _	I	[10 ⁻³ kgm ²]	0,324	0,696	1,847	7,613	14,520	49,106
Weights	Type 494. 0 _ _	m	[kg]	1,06	1,58	2,69	6,31	9,23	21,53
	Type 494. 1 _ _	m	[kg]	1,18	1,74	3,05	6,20	8,91	21,44
	Type 494. 2 _ _	m	[kg]	1,02	2,09	2,70	6,23	9,56	21,09

Clamping screws				Size					
				01	0	1	2	3	4
In cone bushing EAS®-side	Number, dimensions	M	[mm]	6 x M4	6 x M4	8 x M4	8 x M5	8 x M6	8 x M8
	Wrench opening	SW	[mm]	7	7	7	8	10	13
	Tightening torque	T _A	[Nm]	4	4	4	8	12	25
In clamping hub ROBA®-ES-side	Number, dimensions	M ₁	[mm]	1 x M6	1 x M8	1 x M8	1 x M10	1 x M12	1 x M14
	Wrench opening	SW ₁	[mm]	5	6	6	8	10	12
	Tightening torque	T _A	[Nm]	10,5	25	25	70	120	200
In shrink hub ROBA®-ES-side	Number, dimensions	M ₂	[mm]	4 x M5	8 x M5	8 x M6	4 x M8	4 x M8	4 x M12
	Wrench opening	SW ₂	[mm]	4	4	5	6	6	10
	Tightening torque	T _A	[Nm]	6	6	10,5	25	30	75

Dimensions [mm]	Size					
	01	0	1	2	3	4
A	12	13,5	16	17	20,5	46
A ₁	7	8	9	10	12	16
C ₄	47	56,5	69	74	87	130
D ₁	70	85	100	115	135	175
D _H	55	65	80	95	105	135
F	61,5	67	82	97	117	150
F ₂	70	85	100	115	135	166
f	38	44	56	70	84	100
f ₂	5	5	5	6	7	-
f ₄	50	55	70	84	100	-
G ⁹⁾	M5	M6	M8	M8	M8	M10
Min. shaft length g ₄	34	39	42	48	53	93
h	40	48	59	64	75	115
k	2,8	2,8	3,5	4,0	4,0	-
k ₁	2,8	2,8	2,8	3,5	4,0	5,3
L ¹⁰⁾	47	56	67	73	86	130
L ₁ ¹⁰⁾	102	119,5	146	159	182	255
L ₂	95	111,5	138	150	171	240
l ₁	30	35	45	50	56	75
t	10	15	15	20	25	20
t ₁	12	13,5	20	20	21	27,5

Bores [mm]		Size						
		01	0	1	2	3	4	
EAS®-side	d ^{4) 5)}	d _{min}	10	15	22	32	35	40
		d _{max}	20	25	35	45	55	65
ROBA®-ES-side	d _p ^{6) 7)}	d _{p min}	12	15	22	28	32	40
		d _{p max}	20	25	30	40	50	65
EAS®-side	d ₃ ³⁾	d _{3 min}	15	19	20	28	35	45
		d _{3 max}	28	35	45	50	55	80
ROBA®-ES-side	d ₄ ³⁾	d _{4 min}	15	19	20	28	35 ⁸⁾	45
		d _{4 max}	28	38	45	50	60 ⁸⁾	75
EAS®-side	d ₅ ³⁾	d _{5 min}	8	10	12	14	20	38
		d _{5 max}	28	38	45	55	60	80

We reserve the right to make dimensional and constructional alterations.

EAS®-NC short hub

with cone bushing
Type 450_1_0

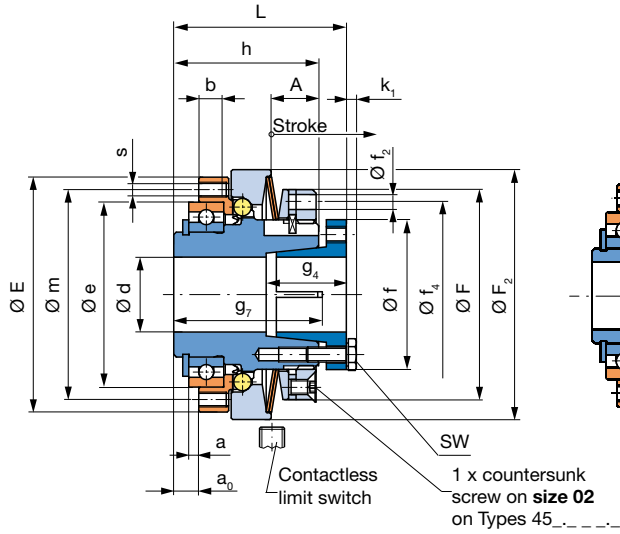

Type 450_2_0
with keyway
Type 450_2_0

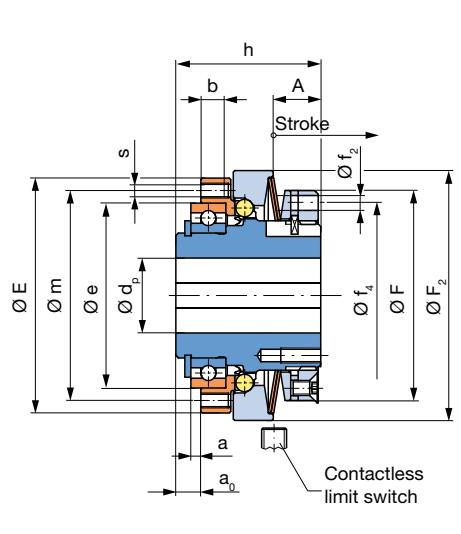

EAS®-NC long protruding hub

with cone bushing
Type 450_1_1

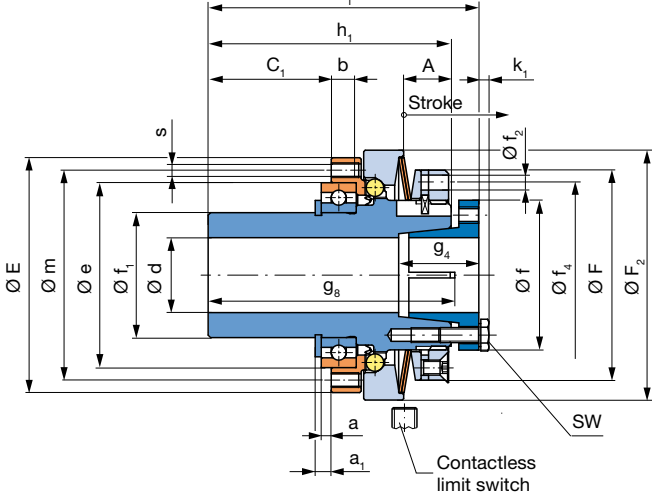

Type 450_2_1
with keyway
Type 450_2_1

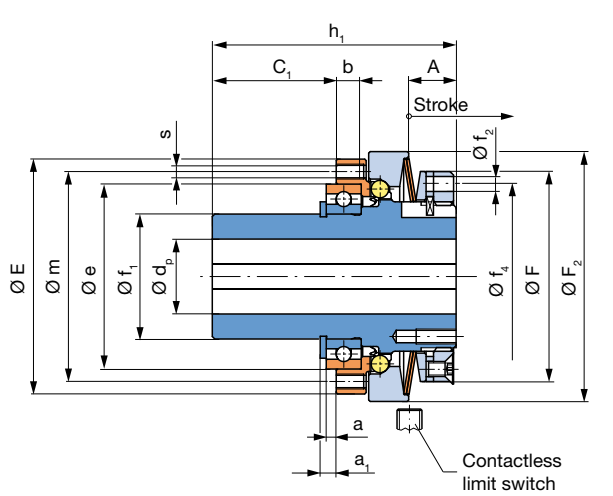

Order Number

	with cone bushing with keyway	1 2	0 5	Ratchetting clutch Synchronous clutch	Torque adjustment value (Optional)
<div style="display: flex; justify-content: space-around; align-items: center;"> — / 4 5 0 . — — . — / — / — / — </div>					
▲	▲	▲	▲	▲	▲
Sizes 03 and 02	Torque range ¹⁾ medium high very high	5 6 7	short hub long protruding hub	0 1	Hub bore Ø d ^{H7} Ø d _p ^{H7}
					With limit switch see page 51-53 (Option)

Example: Order number 02 / 450.610.0 / 15 / 8 / limit switch 055.002.5

1) See Technical Data, limit torque for overload M_G

Technical Data				Size ¹⁾	
				03	02
Limit torques for overload ¹⁾	Type 450.5_ _ _	M _G	[Nm]	0,65 – 1,30	2 – 5
	Type 450.6_ _ _	M _G	[Nm]	1,30 – 2,60	5 – 10
	Type 450.7_ _ _	M _G	[Nm]	2,00 – 3,80	6 – 15
Max. speed	n _{max}	[rpm]		4000	4000
Thrust washer stroke on overload		[mm]		0,8	1,0

Mass moments of inertia and weights				Size	
				03	02
Hub-side	Type 450._1_0	I	[10 ⁻³ kgm ²]	0,027	0,054
	Type 450._2_0	I	[10 ⁻³ kgm ²]	0,025	0,051
	Type 450._1_1	I	[10 ⁻³ kgm ²]	0,028	0,058
	Type 450._2_1	I	[10 ⁻³ kgm ²]	0,026	0,055
Pressure flange-side	Type 450. _ _ _ _	I	[10 ⁻³ kgm ²]	0,008	0,018
Weights	Type 450._1_0	m	[kg]	0,18	0,28
	Type 450._2_0	m	[kg]	0,17	0,26
	Type 450._1_1	m	[kg]	0,20	0,32
	Type 450._2_1	m	[kg]	0,19	0,30

Clamping screws and screw-on bores				Size	
				03	02
Clamping screws in cone bushing	Number, dimensions	M	[mm]	4 x M3	4 x M3
	Wrench opening	SW	[mm]	5,5	5,5
	Tightening torque	T _A	[Nm]	1	1
Screw-on bores in pressure flange	Number, dimensions	s	[mm]	6 x M3	6 x M3

Dimensions [mm]	Size	
	03	02
A	7,2	9,5
a ²⁾	2	2
a ₀	4,5	5,0
a ₁	3,0	3,2
b	5	5
C ₁	20,5	25
E	40	47
e _{h5} ⁴⁾	30	37
F	37	42
F ₂	45	50
f	26	30
f _{1 h6}	17	25
f ₂	-	3
f ₄	-	37
Min. shaft length	g ₄	11,5
	g ₇	25,5
	g ₈	41,5
h	24	29
h ₁	40	49
k ₁	2	2
L ⁶⁾	28,5	34,5
L ₁ ⁶⁾	44,5	54,5
m	35	42

Bores [mm]		Size	
		03	02
d	d _{min}	6	8
	d _{max}	12	15
d _P ³⁾	d _{P min}	6	8
	d _{P max}	11	16 ⁵⁾

We reserve the right to make dimensional and constructional alterations.

- 1) Further sizes for smaller and larger torques available on request
- 2) Mounting tolerance + 0,1
- 3) The position of the keyway to the mounting bore "s" in the pressure flange is not defined. Defined position available on request
- 4) Tolerance user-side H7
- 5) Up to Ø 14 keyway acc. DIN 6885/1, over Ø 14 keyway acc. DIN 6885/3
- 6) Dimensions in untightened condition (shorter in tightened condition)

EAS®-NC double bearing design with cone bushing

Type 450._1_.2
 Sizes 03 and 02

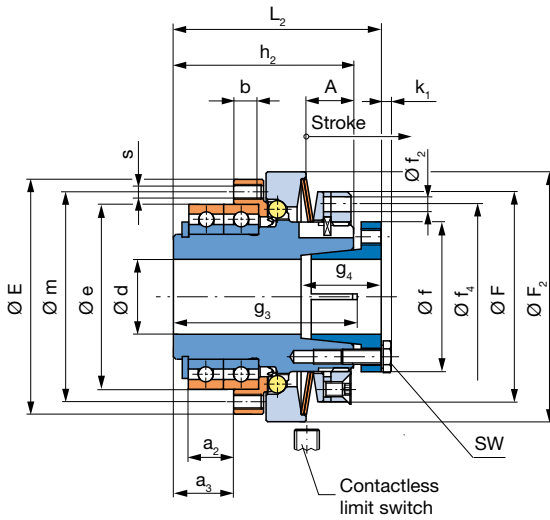

EAS®-NC double bearing design with keyway

Type 450._2_.2
 Sizes 03 and 02

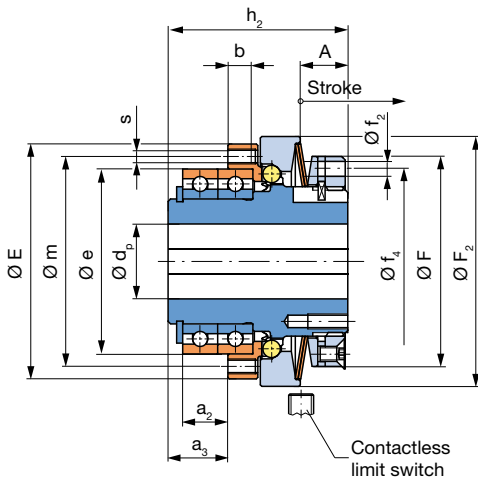

Order Number

with cone bushing		1	0	Ratchetting clutch	Torque adjustment value (Optional)
with keyway		2	5	Synchronous clutch	
▾					
__	/ 4	5	0	.	__
▴					
Sizes 03 and 02	Torque range ¹⁾ medium high very high	5 6 7	2-bearing design	2	Hub bore Ø d ^{H7} Ø d _p ^{H7}
					With limit switch see page 51-53 (Option)

Example: Order number 02 / 450.610.2 / 15 / 8 / limit switch 055.002.5

1) See Technical Data, limit torque for overload M_G

Technical Data				Size ¹⁾	
				03	02
Limit torques for overload ¹⁾	Type 450.5_..2	M _G	[Nm]	0,65 – 1,30	2 – 5
	Type 450.6_..2	M _G	[Nm]	1,30 – 2,60	5 – 10
	Type 450.7_..2	M _G	[Nm]	2,00 – 3,80	6 – 15
Max. speed		n _{max}	[rpm]	4000	4000
Thrust washer stroke on overload			[mm]	0,8	1,0

Mass moments of inertia and weights				Size	
				03	02
Hub-side	Type 450._1_..2	I	[10 ⁻³ kgm ²]	0,028	0,058
	Type 450._2_..2	I	[10 ⁻³ kgm ²]	0,026	0,055
Pressure flange-side	Type 450._..2	I	[10 ⁻³ kgm ²]	0,008	0,018
Weights	Type 450._1_..2	m	[kg]	0,13	0,31
	Type 450._2_..2	m	[kg]	0,18	0,29

Clamping screws and screw-on bores				Size	
				03	02
Clamping screws in cone bushing	Number, dimensions	M	[mm]	4 x M3	4 x M3
	Wrench opening	SW	[mm]	5,5	5,5
	Tightening torque	T _A	[Nm]	1	1
Screw-on bores in pressure flange	Number, dimensions	s	[mm]	6 x M3	6 x M3

Dimensions [mm]	Size		
	03	02	
A	7,2	9,5	
a ₂ ²⁾	9	9	
a ₃	11,5	12	
b	5	5	
E	40	47	
e _{h5} ⁴⁾	30	37	
F	37	42	
F ₂	45	50	
f	26	30	
f ₂	-	3	
f ₄	-	37	
Min. shaft length	g ₃	32,5	37,5
	g ₄	11,5	15,5
h ₂	31	36	
k ₁	2	2	
L ₂ ⁶⁾	35,5	41,5	
m	35	42	

Bores [mm]		Size	
		03	02
d	d _{min}	6	8
	d _{max}	12	15
d _P ³⁾	d _{P min}	6	8
	d _{P max}	11	16 ⁵⁾

We reserve the right to make dimensional and constructional alterations.

- 1) Further sizes for smaller and larger torques available on request
- 2) Mounting tolerance + 0,1
- 3) The position of the keyway to the mounting bore "s" in the pressure flange is not defined. Defined position available on request
- 4) Tolerance user-side H7
- 5) Up to Ø 14 keyway acc. DIN 6885/1, over Ø 14 keyway acc. DIN 6885/3
- 6) Dimensions in untightened condition (shorter in tightened condition)

EAS®-NC with steel bellows coupling

Type 453.____.0
 Sizes 03 and 02

EAS®-side cone bushing,
 Steel bellows-side cone bushing
 Type 453._1_.0

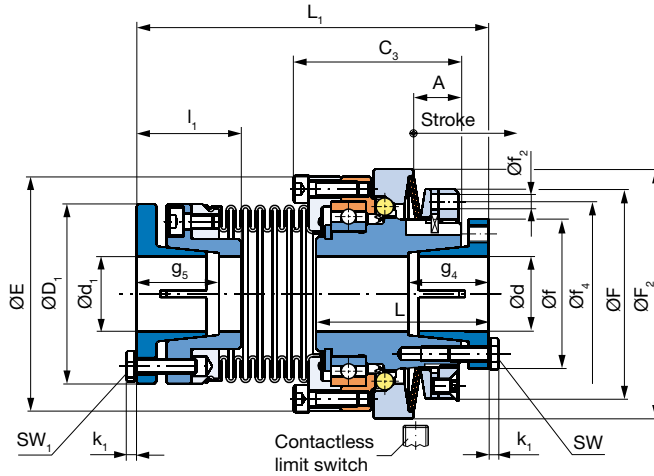

EAS®-side key hub,
 Steel bellows-side key hub
 Type 453._2_.0

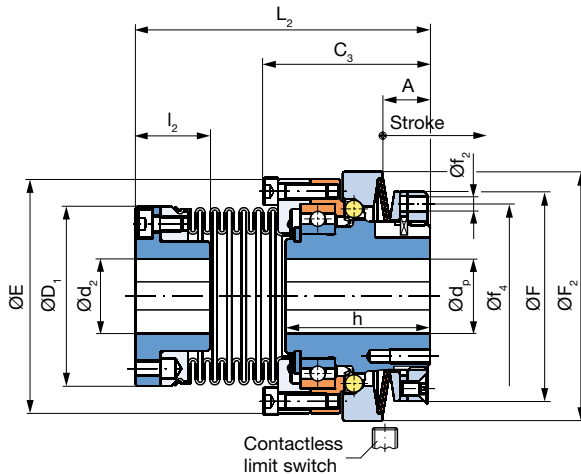

Order Number

EAS®-side Cone bushing Key hub	Steel bellows-side Cone bushing Key hub	1 2	0 5	Ratchetting clutch Synchronous clutch	Torque adjustment value (Optional)
---	--	----------------------	----------------------	--	--

__ / 4 5 3 . __ __ . 0 / __ / __ / __ / __

Sizes 03 and 02	Torque range ¹⁾ medium high very high	5 6 7	Hub 1 bore $\varnothing d^{H7}$ $\varnothing d_p^{H7}$	Hub 2 bore $\varnothing d_1^{H7}$ $\varnothing d_2^{H7}$	With limit switch see page 51-53 (Option)
---------------------------------	--	----------------------------------	--	--	---

Example: Order number 02 / 453.615.0 / 15 / 15 / 8 / limit switch 055.002.5

1) See Technical Data, limit torque for overload M_G

Technical Data				Size ¹⁾	
				03	02
Limit torques for overload ¹⁾	Type 453.5__0	M _G	[Nm]	0,65 – 1,30	2 – 5
	Type 453.6__0	M _G	[Nm]	1,30 – 2,60	5 – 10
	Type 453.7__0	M _G	[Nm]	2,00 – 3,80	6 – 15
Max. speed		n _{max}	[rpm]	4000	4000
Thrust washer stroke on overload			[mm]	0,8	1,0
Nominal torques, steel bellows coupling		T _{KN}	[Nm]	12	25
Permitted misalignments	axial	ΔK _a	[mm]	0,2	0,3
	radial	ΔK _r	[mm]	0,1	0,1
	angular	ΔK _w	[°]	2	2

Mass moments of inertia and weights				Size	
				03	02
Hub-side	Type 453._1_0	I	[10 ⁻³ kgm ²]	0,027	0,054
	Type 453._2_0	I	[10 ⁻³ kgm ²]	0,025	0,051
Steel bellows-side	Type 453._1_0	I	[10 ⁻³ kgm ²]	0,027	0,063
	Type 453._2_0	I	[10 ⁻³ kgm ²]	0,025	0,057
Weights	Type 453._1_0	m	[kg]	0,27	0,45
	Type 453._2_0	m	[kg]	0,24	0,39

Clamping screws				Size	
				03	02
In cone bushing EAS®-side	Number, dimensions	M	[mm]	4 x M3	4 x M3
	Wrench opening	SW	[mm]	5,5	5,5
	Tightening torque	T _A	[Nm]	1,3	1,3
In cone bushing steel bellows-side	Number, dimensions	M ₁	[mm]	4 x M3	4 x M3
	Wrench opening	SW ₁	[mm]	5,5	5,5
	Tightening torque	T _A	[Nm]	1,3	1,3

Dimensions [mm]		Size	
		03	02
A		7,2	9,5
C ₃		28	33,5
D ₁		30	36
E		40	47
F		37	42
F ₂		45	50
f		26	30
f ₂		-	3
f ₄		-	37
Min. shaft length	g ₄	11,5	15,5
	g ₅	12,5	16
h		24	29
k ₁		2	2
L ³⁾		28,5	34,5
L ₁ ³⁾		58,5	70,5
L ₂		49,3	59
l ₁ ³⁾		14	21
l ₂		9,5	15

Bores [mm]		Size		
		03	02	
EAS®-side	d	d _{min}	6	8
		d _{max}	12	15
	d _p	d _{p min}	6	8
		d _{p max}	11	16 ²⁾
Steel bellows-side	d ₁	d _{1 min}	6	8
		d _{1 max}	12	15
	d ₂	d _{2 min}	6	8
		d _{2 max}	11	16 ²⁾

We reserve the right to make dimensional and constructional alterations.

- 1) Further sizes for smaller and larger torques available on request
- 2) Up to Ø 14 keyway acc. DIN 6885/1, over Ø 14 keyway acc. DIN 6885/3
- 3) Dimensions in untightened condition (shorter in tightened condition)

EAS®-Compact® overload clutch

Function

If the set limit torque is exceeded, the clutch disengages. The torque drops immediately. A mounted limit switch registers the disengagement movement and switches off the drive. The limit switch signal can also be used for further control functions.

EAS®-Compact® overload clutches separate the input and the output side completely and remain in this state until they are intentionally re-engaged by hand or via a suitable device.

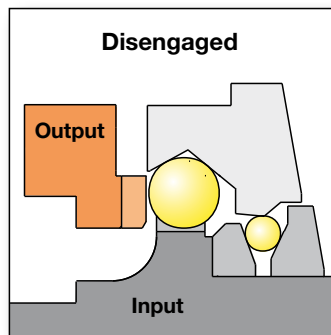
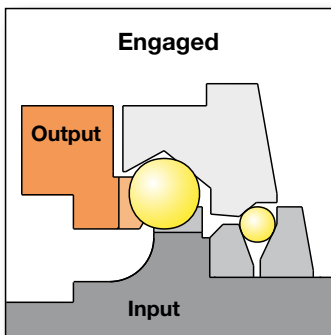
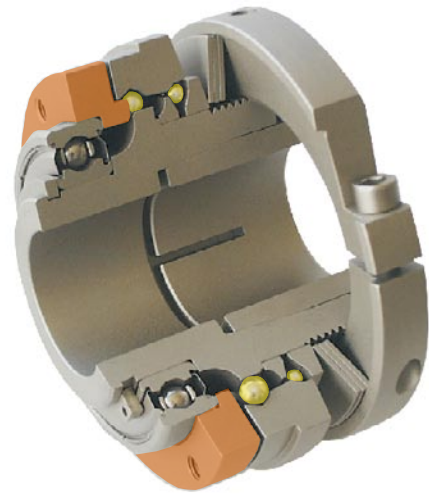

When in operation, the EAS®-Compact® overload clutches transmit the torque backlash-free. On overload occurrence, they ensure free run-out of the drive components.



The EAS®-Compact® overload clutches Type 49_5_4_, 49_6_4_ and 49_7_4_ are also available in ATEX design according to directive 94/9 EC (ATEX 95).

Summary of structural designs EAS®-Compact®

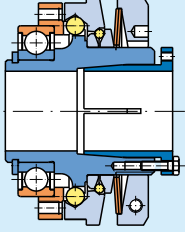
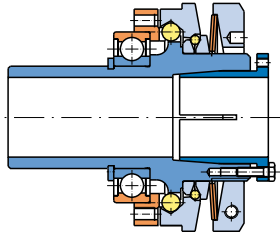
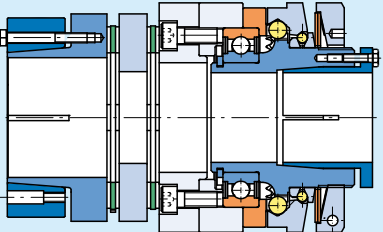
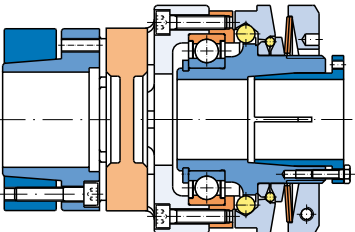
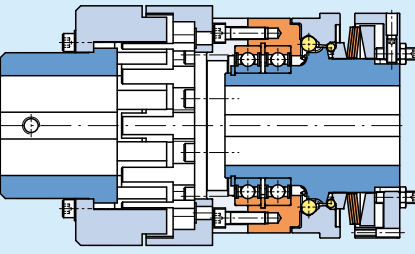
<p>EAS®-Compact® overload short hub</p> 	<p>Torque: 5 to 3.000 Nm</p> <p>Sizes 01 to 3 Type 490._ _ 4.0</p> <p>Sizes 4 and 5 as double bearing design Type 490._ _ 4.2</p>	<ul style="list-style-type: none"> Flange clutch for direct installation of the drive element with the resulting radial force approximately in the bearing centre <p>With cone bushing With keyway</p> <p>Type 490._14._ Type 490._24._</p> <p style="text-align: right;">Page 28</p>
<p>EAS®-Compact® overload long protruding hub</p> 	<p>Torque: 5 to 1.000 Nm</p> <p>Sizes 01 to 3 Type 490._ _ 4.1</p>	<ul style="list-style-type: none"> Flange clutch for very wide drive elements or elements with a very small diameter Suitable bearings for the drive element are ball bearings, needle bearings or plain bearings. <p>With cone bushing With keyway</p> <p>Type 490._14.1 Type 490._24.1</p> <p style="text-align: right;">Page 30</p>
<p>EAS®-Compact® overload torsionally rigid</p> 	<p>Torque: 5 to 3.000 Nm</p> <p>Sizes 01 to 3 Type 496._ _ 4.0</p> <p>Sizes 4 and 5 as double bearing design Type 496._ _ 4.2</p>	<ul style="list-style-type: none"> Double shaft design with a robust disk pack coupling Compensation for axial, radial and angular misalignments High torsional rigidity <p>Hub designs: <u>EAS®-side/torsionally rigid side</u> Cone bushing/Shrink disk hub Type 496._14._ Key hub/clamping hub Type 496._24.0 Key hub/key hub Type 496._24._</p> <p style="text-align: right;">Page 32</p>
<p>EAS®-Compact® overload lastic backlash-free</p> 	<p>Torque: 5 to 1.500 Nm</p> <p>Sizes 01 to 3 Type 494._ _ 4._</p> <p>Size 4 as double bearing design Type 494._ _ 4._</p>	<ul style="list-style-type: none"> Double shaft design with a flexible, backlash-free coupling Compensation for axial, radial and angular misalignments High damping characteristics <p>Hub designs: <u>EAS®-side/flexible side</u> Cone bushing/clamping hub Type 494._04._ Cone bushing/shrink disk hub Type 494._14._ Key hub/key hub Type 494._24._</p> <p style="text-align: right;">Page 36</p>
<p>EAS®-Compact® overload lastic</p> 	<p>Torque: 240 to 3.000 Nm</p> <p>Size 5 as double bearing design Type 494._ _ 4.2</p>	<ul style="list-style-type: none"> Double shaft design with a flexible coupling Compensation for axial, radial and angular misalignments <p>Hub designs: <u>EAS®-side/flexible side</u> Key hub/key hub Type 494._24.2 Cone bushing/key hub Type 494._34.2</p> <p style="text-align: right;">Page 40</p>

EAS®-Compact® overload short hub with cone bushing

**Type 490._14._
Sizes 01 to 5**

Type 490._14.0, Sizes 01 to 3

Type 490._14.2, Sizes 4 to 5

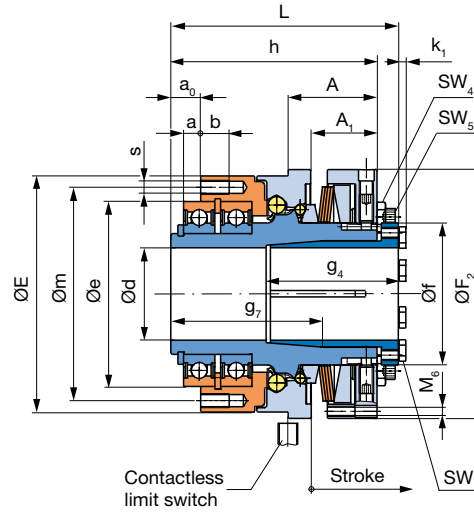
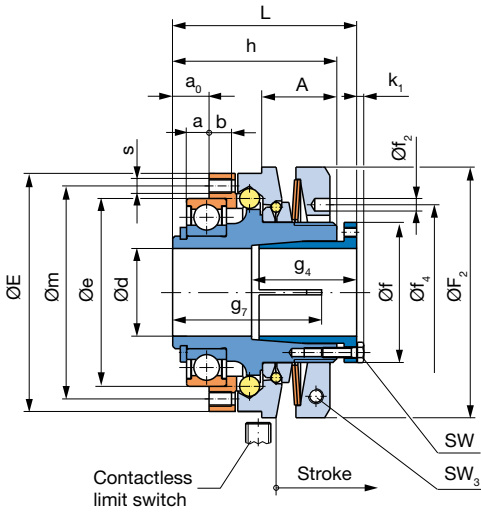

EAS®-Compact® overload short hub with keyway

**Type 490._24._
Sizes 01 to 5**

Type 490._24.0, Sizes 01 to 3

Type 490._24.2, Sizes 4 to 5

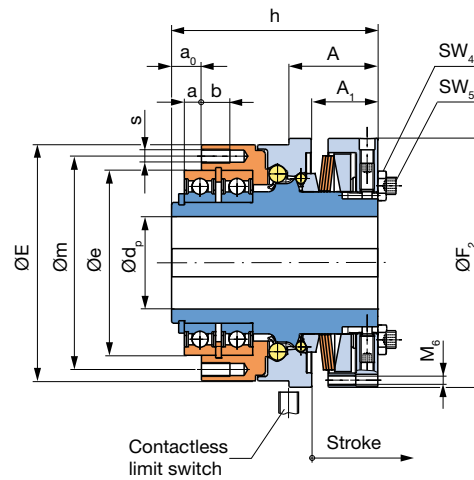
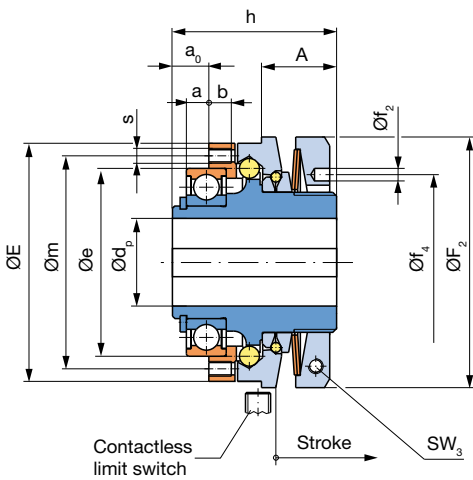

Order Number

		with cone bushing	1							Torque adjustment value (Optional)
		with keyway	2							
				4	Overload clutch					
Sizes	Torque range ¹⁾									
01	medium		5	1-bearing design (Sizes 01-3)	0	Hub bore	With limit switch see page 51 (Option)			
to	high		6	2-bearing design (Sizes 4-5)	2	Ø d ^{H7}				
5	very high maximum		7			Ø d _p ^{H7}				
			8							

Example: Order number 1 / 490.614.0 / 25 / 60 / limit switch 055.002.5

1) See Technical Data, limit torque for overload M_G

Technical Data				Size ¹⁾						
				01	0	1	2	3	4	5
Limit torques for overload ¹⁾	Type 490.5_4_	M _G	[Nm]	5–12,5	10– 25	20– 50	40–100	80– 200	120– 300	240– 600
	Type 490.6_4_	M _G	[Nm]	10–25	20– 50	40–100	80–200	160– 400	240– 600	480–1200
	Type 490.7_4_	M _G	[Nm]	20–50	40–100	80–200	160–400	320– 800	480–1200	960–2400
	Type 490.8_4_	M _G	[Nm]	25–62,5	50–125	100–250	200–500	400–1000	600–1500	1200–3000
Max. speed	n _{max}		[rpm]	8000	7000	6000	5000	4000	3500	3000
Thrust washer stroke on overload			[mm]	2,0	2,6	3,2	3,8	4,5	5,5	6,5

Mass moments of inertia and weights				Size						
				01	0	1	2	3	4	5
Hub-side	Type 490_14_	I	[10 ⁻³ kgm ²]	0,383	0,943	2,279	4,421	10,396	39,730	120,834
	Type 490_24_	I	[10 ⁻³ kgm ²]	0,377	0,917	2,193	4,205	9,867	37,215	112,399
Pressure flange-side	Type 490_14_	I	[10 ⁻³ kgm ²]	0,093	0,234	0,643	1,306	2,649	19,950	65,760
	Type 490_24_	I	[10 ⁻³ kgm ²]	0,093	0,234	0,643	1,306	2,649	19,950	65,760
Weights	Type 490_14_	m	[kg]	0,92	1,55	2,58	3,70	5,83	17,10	34,70
	Type 490_24_	m	[kg]	0,87	1,43	2,35	3,37	5,31	16,50	34,30

Screws and screw-on bores				Size						
				01	0	1	2	3	4	5
Clamping screws in cone bushing	Number, dimensions	M	[mm]	6 x M4	6 x M4	8 x M4	8 x M5	8 x M6	8 x M8	8 x M10
	Wrench opening	SW	[mm]	7	7	7	8	10	13	16
	Tightening torque	T _A	[Nm]	4	4	4	8	12	25	71
Locking screw in adjusting nut Sizes 01 - 3	Number, dimensions	M ₃	[mm]	1 x M4	1 x M4	1 x M5	1 x M5	1 x M6	-	-
	Wrench opening	SW ₃	[mm]	3	3	4	4	5	-	-
	Tightening torque	T _A	[Nm]	3	5	9	9	15	-	-
Pins/threads in adjusting nut Sizes 4 - 5	Wrench opening	SW ₄	[mm]	-	-	-	-	-	18	18
	Wrench opening	SW ₅	[mm]	-	-	-	-	-	6	6
	Number, dimensions	M ₆	[mm]	-	-	-	-	-	3 x M8	3 x M8
Screw-on bores in pressure flange	Number, dimensions	s	[mm]	8 x M4	8 x M5	8 x M6	8 x M6 *	8 x M8 *	8 x M10	8 x M12
	* For clutch operation from "torque range high (Type 490.6_4_)" and above, screws quality class 12.9 must be used to secure the drive element.									

Dimensions [mm]	Size						
	01	0	1	2	3	4	5
A	24	28	30	34	40	62,5	80
A ₁	-	-	-	-	-	46,5	60
a ²⁾	5	7	9	10	10	12	13
a ₀	8	11	14	16	18	21	23
b	6	7	9	10	12	20	20
E	65	80	95	110	130	166	215
e _{h5} ³⁾	47	62	75	90	100	130	160
F ₂	70	85	100	115	135	175	225
f	38	44	56	70	84	100	134
f ₂	5	5	5	6	7	-	-
f ₄	50	55	70	84	100	-	-
Min. shaft length	g ₄	34	39	42	48	53	93
	g ₇	36	43	54	57	69	110
h	45	55	65	72	82	145	175
k ₁	2,8	2,8	2,8	3,5	4,0	5,3	6,4
L ⁴⁾	52	63	73	81	93	160	193
m	56	71	85	100	116	150	185

Bores [mm]		Size						
		01	0	1	2	3	4	5
d ^{5) 6)}	d _{min}	10	15	22	32	35	40	45
	d _{max}	20	25	35	45	55	65	85
d _p	d _{p min} ⁷⁾	12	15	22	28	32	40	45
	d _{p max} ⁸⁾	20	25	30	40	50	65	80

We reserve the right to make dimensional and constructional alterations.

- 1) Further sizes for smaller and larger torques available on request
- 2) Mounting tolerance + 0,1
- 3) Tolerance user-side H7
- 4) Dimensions in untightened condition (shorter in tightened condition)
- 5) Shaft tolerance up to Ø 38_{h6} over Ø 38_{h8}
- 6) Transmittable torques with smaller bores available on request
- 7) Smaller bores for low torques available on request
- 8) Larger bores available on request

Technical Data				Size ¹⁾				
				01	0	1	2	3
Limit torques for overload ¹⁾	Type 490.5_4.1	M _G	[Nm]	5 – 12,5	10 – 25	20 – 50	40 – 100	80 – 200
	Type 490.6_4.1	M _G	[Nm]	10 – 25	20 – 50	40 – 100	80 – 200	160 – 400
	Type 490.7_4.1	M _G	[Nm]	20 – 50	40 – 100	80 – 200	160 – 400	320 – 800
	Type 490.8_4.1	M _G	[Nm]	25 – 62,5	50 – 125	100 – 250	200 – 500	400 – 1000
Max. speed	n _{max}	[rpm]	8000	7000	6000	5000	4000	
Thrust washer stroke on overload		[mm]	2,0	2,6	3,2	3,8	4,5	

Mass moments of inertia and weights				Size				
				01	0	1	2	3
Hub-side	Type 490._14.1	I	[10 ⁻³ kgm ²]	0,397	1,000	2,382	4,680	10,888
	Type 490._24.1	I	[10 ⁻³ kgm ²]	0,391	0,974	2,296	4,464	10,389
Pressure flange-side	Type 490._14.1	I	[10 ⁻³ kgm ²]	0,093	0,234	0,643	1,306	2,649
	Type 490._24.1	I	[10 ⁻³ kgm ²]	0,093	0,234	0,643	1,306	2,649
Weights	Type 490._14.1	m	[kg]	1,02	1,77	2,86	4,16	6,42
	Type 490._24.1	m	[kg]	0,97	1,65	2,64	3,82	5,90

Screws and screw-on bores				Size				
				01	0	1	2	3
Clamping screws in cone bushing	Number, dimensions	M	[mm]	6 x M4	6 x M4	8 x M4	8 x M5	8 x M6
	Wrench opening	SW	[mm]	7	7	7	8	10
	Tightening torque	T _A	[Nm]	4	4	4	8	12
Locking screw in adjusting nut	Number, dimensions	M ₃	[mm]	1 x M4	1 x M4	1 x M5	1 x M5	1 x M6
	Wrench opening	SW ₃	[mm]	3	3	4	4	5
	Tightening torque	T _A	[Nm]	3	5	9	9	15
Screw-on bores in pressure flange	Number, dimensions	s	[mm]	8 x M4	8 x M5	8 x M6	8 x M6 *	8 x M8 *
	* For clutch operation from "torque range high (Type 490.6_4.1)" and above, screws quality class 12.9 must be used to secure the drive element.							

Dimensions [mm]	Size					
	01	0	1	2	3	
A	24	28	30	34	40	
a ²⁾	5	7	9	10	10	
a ₁	6,5	8,75	11,5	13	14	
b	6	7	9	10	12	
C ₁	33	43	55	67	73	
E	65	80	95	110	130	
e _{h5} ³⁾	47	62	75	90	100	
F ₂	70	85	100	115	135	
f	38	44	56	70	84	
f _{1,h6}	30	40	45	55	65	
f ₂	5	5	5	6	7	
f ₄	50	55	70	84	100	
Min. shaft length	g ₄	34	39	42	48	53
	g ₈	61	75	95	108	124
h ₁	70	87	106	123	137	
k ₁	2,8	2,8	2,8	3,5	4,0	
L ₁ ⁴⁾	77	95	114	132	148	
m	56	71	85	100	116	

Bores [mm]	Size					
	01	0	1	2	3	
d ^{5) 6)}	d _{min}	10	15	22	32	35
	d _{max}	20	25	35	45	55
d _p	d _{p min} ⁷⁾	12	15	22	28	32
	d _{p max} ⁸⁾	20	25	30	40	50

We reserve the right to make dimensional and constructional alterations.

- 1) Further sizes for smaller and larger torques available on request
- 2) Mounting tolerance + 0,1
- 3) Tolerance user-side H7
- 4) Dimensions in untightened condition (shorter in tightened condition)
- 5) Shaft tolerance up to Ø 38_{h6} over Ø 38_{h8}
- 6) Transmittable torques with smaller bores available on request
- 7) Smaller bores for low torques available on request
- 8) Larger bores available on request

EAS®-Compact® overload clutch torsionally rigid

Type 496._ 4.0

Sizes 01 to 3

EAS®-side cone bushing,
ROBA®-DS-side shrink disk hub
Type 496._14.0, Sizes 01 to 3

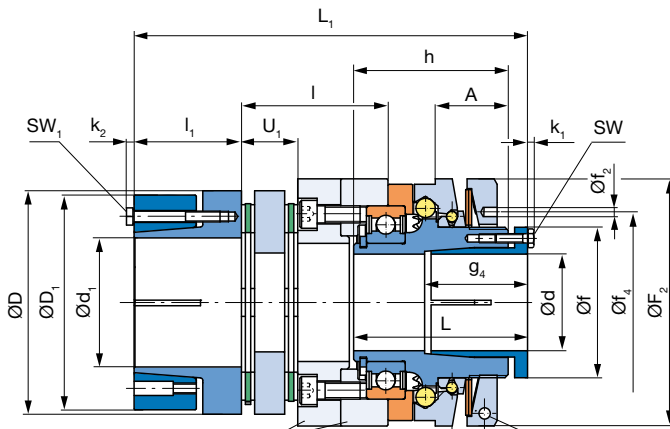

1-part flange sizes 01 and 1
2-part flange sizes 0, 2 and 3

Contactless limit switch
Stroke
SW₂

All EAS®-Compact® clutches can be combined with almost all components of the ROBA®-DS backlash-free shaft coupling. The Types shown here represent only a selection of the most established designs.
For further combination possibilities, see page 43.
We are happy to assist you in dimensioning and assembling your optimum clutch.

EAS®-side key hub,
ROBA®-DS-side clamping hub with keyway
Type 496._24.0, Sizes 01 and 0

EAS®-side key hub,
ROBA®-DS-side key hub
Type 496._24.0, Sizes 1 to 3

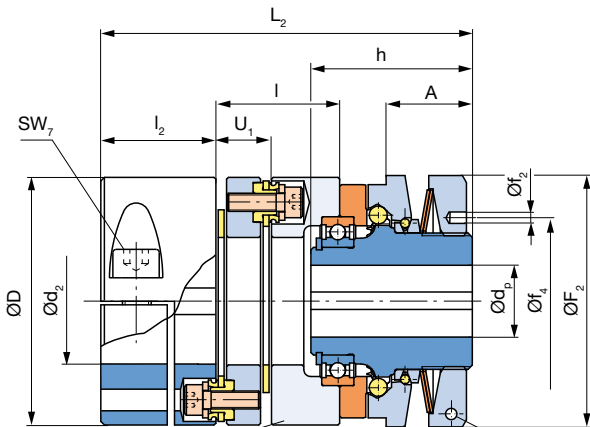

1-part flange size 01
2-part flange size 0

Contactless limit switch
Stroke
SW₂

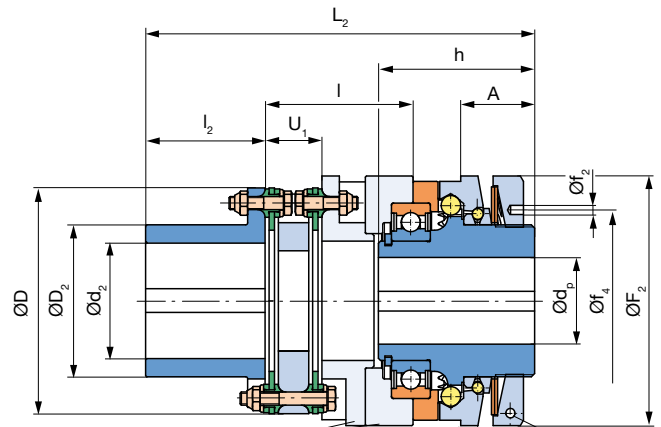

1-part flange size 1
2-part flange sizes 2 and 3

Contactless limit switch
Stroke
SW₂

Order Number

EAS®-side Cone bushing Key hub	ROBA®-DS-side Shrink disk hub Clamping hub with keyway (sizes 01-0)/key hub (sizes 1-3)	1 2	4	Overload clutch	Torque adjustment value (Optional)
--------------------------------------	--	--------	---	-----------------	------------------------------------

— / 4 9 6 . — — 4 . 0 / — / — / — / —

Sizes 01 to 3	Torque range ¹⁾ medium high very high maximum	5 6 7 8	Hub 1 bore Ø d ^{H7}	Hub 2 bore Ø d ^{H7} Ø d _p ^{H7}	With limit switch see page 51 (Option)
-------------------------------	---	------------------	---------------------------------	---	--

Example: Order number 1 / 496.614.0 / 30 / 30 / 60 / limit switch 055.002.5

1) See Technical Data, limit torque for overload M_G

Technical Data				Size				
				01	0	1	2	3
Limit torques for overload	Type 496.5_4.0	M_G	[Nm]	5 – 12,5	10 – 25	20 – 50	40 – 100	80 – 200
	Type 496.6_4.0	M_G	[Nm]	10 – 25	20 – 50	40 – 100	80 – 200	160 – 400
	Type 496.7_4.0	M_G	[Nm]	20 – 50	40 – 100	80 – 200	160 – 400	320 – 800
	Type 496.8_4.0	M_G	[Nm]	25 – 62,5	50 – 125	100 – 250	200 – 500	400 – 1000
Max. speed	n_{max}	[rpm]	8000	7000	6000	5000	4000	
Thrust washer stroke on overload		[mm]	2,0	2,6	3,2	3,8	4,5	
Nominal torques, torsionally rigid coupling	T_{KN}	[Nm]	100	150	300	650	1100	
Permitted misalignments	axial ¹⁾	ΔK_a	[mm]	0,9	1,1	0,8	1,1	1,3
	radial	ΔK_r	[mm]	0,20	0,20	0,20	0,25	0,30
	angular	ΔK_w	[°]	2,0	2,0	1,4	1,4	1,4

Mass moments of inertia and weights				Size				
				01	0	1	2	3
EAS®-hub-side	Type 496_14.0	I	[10 ⁻³ kgm ²]	0,383	0,943	2,279	4,421	10,396
	Type 496_24.0	I	[10 ⁻³ kgm ²]	0,377	0,917	2,193	4,205	9,867
ROBA®-DS-side	Type 496_14.0	I	[10 ⁻³ kgm ²]	0,894	2,395	2,915	9,543	21,443
	Type 496_24.0	I	[10 ⁻³ kgm ²]	0,709	2,086	2,417	7,815	18,215
Weights	Type 496_14.0	m	[kg]	1,81	3,34	4,34	7,81	12,75
	Type 496_24.0	m	[kg]	1,65	3,07	4,01	7,12	14,94

Screws				Size				
				01	0	1	2	3
In cone bushing EAS®-side	Number, dimensions	M	[mm]	6 x M4	6 x M4	8 x M4	8 x M5	8 x M6
	Wrench opening	SW	[mm]	7	7	7	8	10
	Tightening torque	T_A	[Nm]	4	4	4	8	12
Locking screw in adjusting nut	Number, dimensions	M_3	[mm]	1 x M4	1 x M4	1 x M5	1 x M5	1 x M6
	Wrench opening	SW_3	[mm]	3	3	4	4	5
	Tightening torque	T_A	[Nm]	3	5	9	9	15
In shrink disk ROBA®-DS-side	Number, dimensions	M_1	[mm]	4 x M5	6 x M5	6 x M5	6 x M5	6 x M6
	Wrench opening	SW_1	[mm]	8	8	8	8	10
	Tightening torque	T_A	[Nm]	6	6	6	8,5	10
In clamping hub ROBA®-DS-side	Number, dimensions	M_7	[mm]	1 x M8	1 x M8	-	-	-
	Wrench opening	SW_7	[mm]	6	6	-	-	-
	Tightening torque	T_A	[Nm]	33	33	-	-	-

Dimensions [mm]	Size				
	01	0	1	2	3
A	24	28	30	34	40
D	69	79	77	104	123
D ₁	68	78	77	100	115
D ₂	-	-	50	70	80
F ₂	70	85	100	115	135
f	38	44	56	70	84
f ₂	5	5	5	6	7
f ₄	50	55	70	84	100
Min. shaft length g ₄	34	39	42	48	53
h	45	55	65	72	82
k ₁	2,8	2,8	2,8	3,5	4,0
k ₂	3,5	3,5	3,5	3,5	4,0
L ²⁾	52	63	73	81	93
L ₁ ²⁾	110,3	140,1	147,1	183,2	215
L ₂	103,3	128,1	139,1	177,2	219
l	34,3	50,6	48,2	68,2	85
l ₁	32	37,5	40	50	55
l ₂	32	33,5	40	55	65
U ₁	15,3	16,6	21,2	26,2	34

Bores [mm]		Size					
		01	0	1	2	3	
EAS®-side	d ³⁾	d _{min}	10	15	22	32	35
		d _{max}	20	25	35	45	55
	d _p	d _{p min}	12	15	22	28	32
		d _{p max}	20	25	30	40	50
ROBA®-DS-side	d ₁ ⁴⁾	d _{1 min}	19	25	25	40	45
		d _{1 max}	38	45	45	60	70
	d ₂	d _{2 min}	19 ⁵⁾	25 ⁵⁾	16	25	30
		d _{2 max}	35 ⁵⁾	42 ⁵⁾	32	50	55

We reserve the right to make dimensional and constructional alterations.

- 1) Only permitted as a static or virtually static value
- 2) Dimensions in untightened condition (shorter in tightened condition)
- 3) Shaft tolerance up to Ø 38 _{h6} over Ø 38 _{h8}
- 4) Recommended shaft tolerance _{g6}
- 5) Recommended shaft tolerance _{k6}

EAS®-Compact® overload torsionally rigid

Type 496._ 4.2
 Sizes 4 and 5

EAS®-side cone bushing,
 ROBA®-DS-side shrink disk hub
 Type 496._14.2

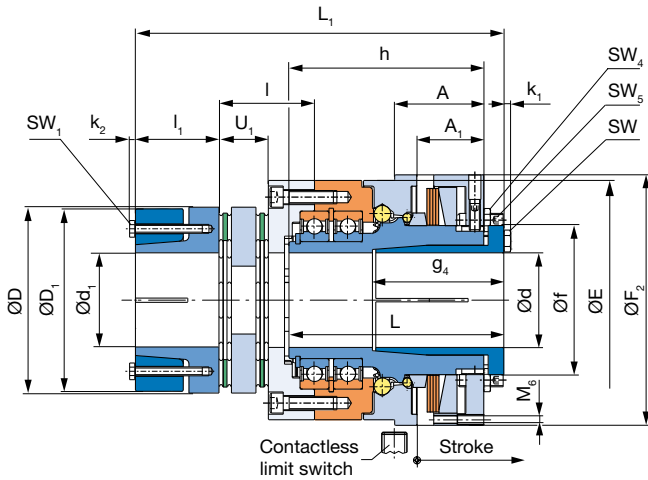

All EAS®-Compact® clutches can be combined with almost all components of the ROBA®-DS backlash-free shaft coupling. The Types shown here represent only a selection of the most established designs.

For further combination possibilities, see page 43.

We are happy to assist you in dimensioning and assembling your optimum clutch.

EAS®-side key hub,
 ROBA®-DS-side key hub
 Type 496._24.2

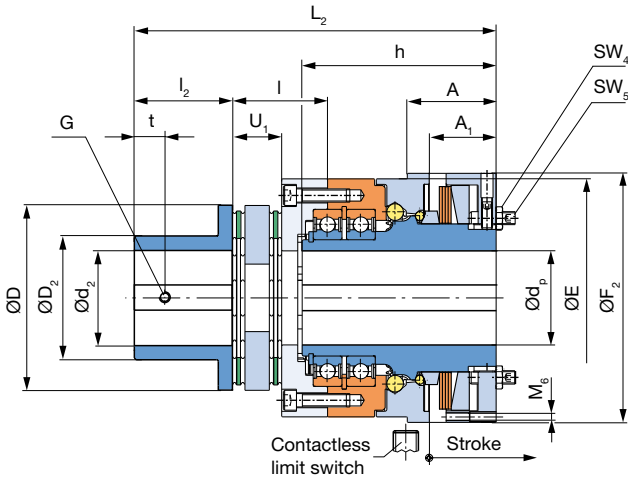

Order Number

EAS®-side Cone bushing Key hub	ROBA®-DS-side Shrink disk hub Key hub	1 2	4	Overload clutch	Torque adjustment value (Optional)
---	--	----------------------	----------	-----------------	------------------------------------

___ / 4 9 6 . ___ ___ 4 . 2 / ___ / ___ / ___ / ___

Sizes 4 and 5	Torque range ¹⁾ medium high very high maximum	5 6 7 8	2-bearing design	2	Hub 1 bore $\odot d^{H7}$ $\odot d_p^{H7}$	Hub 2 bore $\odot d_1^{H7}$ $\odot d_2^{H7}$	With limit switch see page 51 (Option)
-------------------------------	---	--	------------------	----------	--	--	--

Example: Order number 5 / 496.714.2 / 70 / 70 / 1500 / limit switch 055.002.5

1) See Technical Data, limit torque for overload M_G

Technical Data				Size	
				4	5
Limit torques for overload	Type 496.5_4.2	M_G [Nm]	120 – 300	240 – 600	
	Type 496.6_4.2	M_G [Nm]	240 – 600	480 – 1200	
	Type 496.7_4.2	M_G [Nm]	480 – 1200	960 – 2400	
	Type 496.8_4.2	M_G [Nm]	600 – 1500	1200 – 3000	
Max. speed	n_{max} [rpm]		3500	3000	
Thrust washer stroke on overload		[mm]	5,5	6,5	
Nominal torques, torsionally rigid coupling	T_{KN} [Nm]		1600	3500	
Permitted misalignments	axial ¹⁾	ΔK_a [mm]	1,5	1,2	
	radial	ΔK_r [mm]	0,30	0,25	
	angular	ΔK_w [°]	1,4	1,0	

Mass moments of inertia and weights				Size	
				4	5
EAS®-hub-side	Type 496._14.2	I [10^{-3} kgm ²]	39,730	120,834	
	Type 496._24.2	I [10^{-3} kgm ²]	37,215	112,399	
ROBA®-DS-side	Type 496._14.2	I [10^{-3} kgm ²]	32,310	147,080	
	Type 496._24.2	I [10^{-3} kgm ²]	26,050	128,580	
Weights	Type 496._14.2	m [kg]	27,30	52,18	
	Type 496._24.2	m [kg]	26,10	48,60	

Screws				Size	
				4	5
In cone bushing EAS®-side	Number, dimensions	M [mm]	8 x M8	8 x M10	
	Wrench opening	SW [mm]	13	16	
	Tightening torque	T_A [Nm]	25	71	
In shrink disk ROBA®-DS-side	Number, dimensions	M_1 [mm]	6 x M8	8 x M8	
	Wrench opening	SW_1 [mm]	13	13	
	Tightening torque	T_A [Nm]	25	35	
Pins/threads in adjusting nut	Wrench opening	SW_4 [mm]	18	18	
	Wrench opening	SW_5 [mm]	6	6	
	Number, dimensions	M_6 [mm]	3 x M8	3 x M8	

Dimensions [mm]	Size	
	4	5
A	62,5	80
A ₁	46,5	60
D	143	167
D ₁	143	164
D ₂	100	121
E	166	215
F ₂	175	225
f	100	134
G	²⁾	M12
Min. shaft length g ₄	93	118
h	145	175
k ₁	5,3	6,4
k ₂	5,3	5,3
L ³⁾	160	193
L ₁ ³⁾	267	331
L ₂	267	328
l	68	86
l ₁	60	75
l ₂	75	90
t	21	25
U ₁	35,2	44,4

Bores [mm]		Size		
		4	5	
EAS®-side	d ⁴⁾	d _{min}	40	45
		d _{max}	65	85
	d _p	d _{p min}	40	45
		d _{p max}	65	80
ROBA®-DS-side	d ₁ ⁵⁾	d _{1 min}	55	50
		d _{1 max}	90	85
	d ₂	d _{2 min}	35	45
		d _{2 max}	70	90

We reserve the right to make dimensional and constructional alterations.

- 1) Only permitted as a static or virtually static value
- 2) Up to Ø 44 M8, over Ø 44 M10
- 3) Dimensions in untightened condition (shorter in tightened condition)
- 4) Shaft tolerance h_8
- 5) Recommended shaft tolerance g_6

EAS®-Compact® overload lastic backlash-free

Type 494._4._

Sizes 01 to 4

EAS®-side cone bushing, ROBA®-ES-side shrink disk hub

Type 494._14._, Sizes 01 to 3

Type 494._14._, Size 4

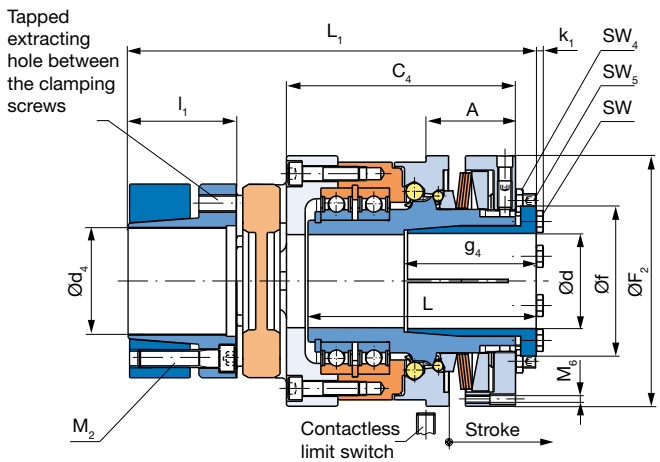
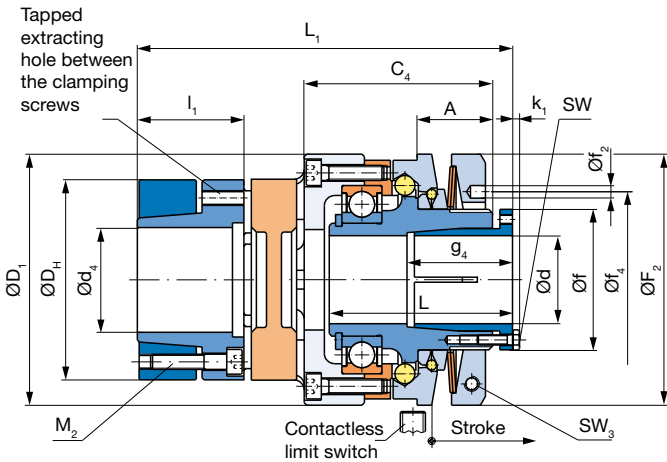

The missing dimensions (ØD, and ØD_H) are identical to sizes 01 to 3, Type 494._14._

EAS®-side cone bushing, ROBA®-ES-side clamping hub

Type 494._04._, Sizes 01 to 3

Type 494._04._, Size 4

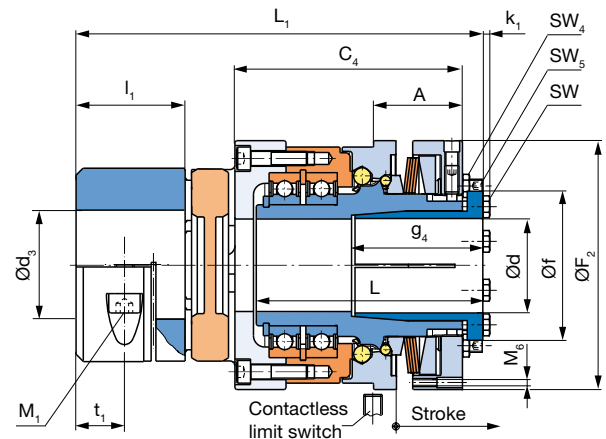
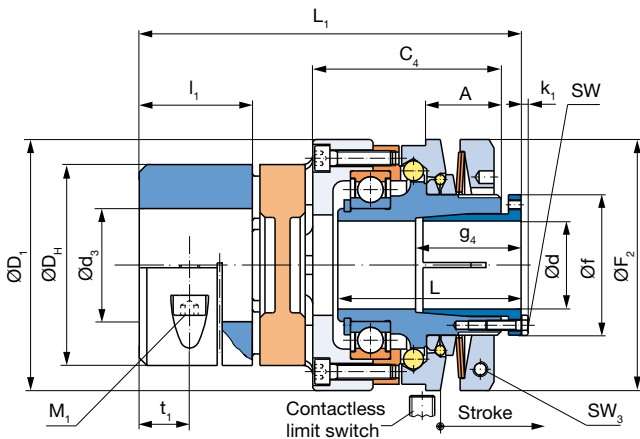

The missing dimensions (ØD, and ØD_H) are identical to sizes 01 to 3, Type 494._04._

Order Number

EAS®-side	ROBA®-ES-side		Overload clutch				Torque adjustment value (Optional)	
Cone bushing	Clamping hub	0						
Cone bushing	Shrink disk hub	1	4					
		▼	▼			▼		
		▲	▲			▲		
Sizes	Torque range ¹⁾		Flexible coupling		Hub 1 bore	Hub 2 bore	With limit switch	
01	medium	5	92 Shore A	3	Ø d ^{H7}	Ø d ₃ ^{F7}	see page 51	
to	high	6	98 Shore A	4		Ø d ₄ ^{H7}	(Option)	
4	very high	7	64 Shore D	6				
	maximum	8						

Example: Order number 1 / 494.614.3 / 22 / 25 / 60 / limit switch 055.002.5

1) See Technical Data, limit torque for overload M_G
 2) The transmittable torques on the flexible coupling "TKN" are dependent on factors such as temperature, torsional rigidity, etc., see also coupling dimensioning ROBA®-ES catalogue K.940.V__ or contact the manufacturer. Furthermore, the transmittable torques of the flexible coupling are dependent on the bore diameter d₃ or d₄, see also Table 1 on page 50.

3) Dimensions in untightened condition (shorter in tightened condition)
 4) Shaft tolerance Ø 38_{h6/7} over Ø 38_{h8}
 5) Transmittable torques with smaller bores available on request
 6) Shaft tolerance Ø 40_{j6}

Technical Data				Size						
				01	0	1	2	3	4	
Limit torques for overload ²⁾	Type 494.5_4_	M_G	[Nm]	5 – 12,5	10 – 25	20 – 50	40 – 100	80 – 200	120 – 300	
	Type 494.6_4_	M_G	[Nm]	10 – 25	20 – 50	40 – 100	80 – 200	160 – 400	240 – 600	
	Type 494.7_4_	M_G	[Nm]	20 – 50	40 – 100	80 – 200	160 – 400	320 – 800	480 – 1200	
	Type 494.8_4_	M_G	[Nm]	25 – 62,5	50 – 125	100 – 250	200 – 500	400 – 1000	600 – 1500	
Max. speed		n_{maxi}	[rpm]	8000	7000	6000	5000	4000	3500	
Thrust washer stroke on overload										
Nominal and maximum torques ²⁾ , flexible coupling	92 Shore A	$T_{KN}/T_{K max}$	[Nm]	35 / 70	95 / 190	190 / 380	265 / 530	310 / 620	900 / 1800	
	98 Shore A	$T_{KN}/T_{K max}$	[Nm]	60 / 120	160 / 320	325 / 650	450 / 900	525 / 1050	1040 / 2080	
	64 Shore D	$T_{KN}/T_{K max}$	[Nm]	75 / 150	200 / 400	405 / 810	560 / 1120	655 / 1310	1250 / 2500	
Permitted misalignments	axial	ΔK_a	[mm]	1,4	1,5	1,8	2,0	2,1	2,6	
		92 Shore A	ΔK_r	[mm]	0,14	0,15	0,17	0,19	0,21	0,25
	radial	98 Shore A	ΔK_r	[mm]	0,10	0,11	0,12	0,14	0,16	0,18
		64 Shore D	ΔK_r	[mm]	0,07	0,08	0,09	0,10	0,11	0,13
	angular	92 Shore A	ΔK_w	[°]	1,0	1,0	1,0	1,0	1,0	1,0
		98 Shore A	ΔK_w	[°]	0,9	0,9	0,9	0,9	0,9	0,9
		64 Shore D	ΔK_w	[°]	0,8	0,8	0,8	0,8	0,8	0,8

Mass moments of inertia and weights				Size					
				01	0	1	2	3	4
EAS®-hub-side	Type 494_4_	I	[10 ⁻³ kgm ²]	0,383	0,943	2,279	4,421	10,396	39,730
ROBA®-ES-side	Type 494_14_	I	[10 ⁻³ kgm ²]	0,378	0,832	2,277	7,25	14,167	61,674
	Type 494_04_	I	[10 ⁻³ kgm ²]	0,320	0,691	1,843	7,40	14,529	62,369
Weights	Type 494_14_	m	[kg]	1,38	2,16	3,64	6,69	10,11	27,61
	Type 494_04_	m	[kg]	1,27	1,98	3,25	6,81	10,42	27,67

Screws				Size					
				01	0	1	2	3	4
In cone bushing EAS®-side	Number, dimensions	M	[mm]	6 x M4	6 x M4	8 x M4	8 x M5	8 x M6	8 x M8
	Wrench opening	SW	[mm]	7	7	7	8	10	13
	Tightening torque	T_A	[Nm]	4	4	4	8	12	25
In shrink disk ROBA®-ES-side	Number, dimensions	M_2	[mm]	4 x M5	8 x M5	8 x M6	4 x M8	4 x M8	4 x M12
	Wrench opening	SW_2	[mm]	4	4	5	6	8	10
	Tightening torque	T_A	[Nm]	6	6	10,5	25	30	120
In clamping hub ROBA®-ES-side	Number, dimensions	M_1	[mm]	1 x M6	1 x M8	1 x M8	1 x M10	1 x M12	1 x M14
	Wrench opening	SW_1	[mm]	5	6	6	8	10	12
	Tightening torque	T_A	[Nm]	10	25	25	70	120	200
Locking screw in adjusting nut Sizes 01 - 3	Number, dimensions	M_3	[mm]	1 x M4	1 x M4	1 x M5	1 x M5	1 x M6	-
	Wrench opening	SW_3	[mm]	3	3	4	4	5	-
	Tightening torque	T_A	[Nm]	3	5	9	9	15	-
Pins/threads in adjusting nut Size 4	Wrench opening	SW_4	[mm]	-	-	-	-	-	18
	Wrench opening	SW_5	[mm]	-	-	-	-	-	6
	Number, dimensions	M_6	[mm]	-	-	-	-	-	3 x M8

Dimensions [mm]	Size					
	01	0	1	2	3	4
A	24	28	30	34	40	62,5
C ₄	52	63,5	75	82	94	160
D ₁	70	85	100	115	135	175
D _H	55	65	80	95	105	135
F ₂	70	85	100	115	135	175
f	38	44	56	70	84	100
f ₂	5	5	5	6	7	-
f ₄	50	55	70	84	100	-
Min. shaft length g ₄	34	39	42	48	53	93
k ₁	2,8	2,8	2,8	3,5	4,0	5,3
L ³⁾	52	63	73	81	93	160
L ₁ ³⁾	107	126,5	152	167	189	270
l ₁	30	35	45	50	56	75
t ₁	12	13,5	20	20	21	27,5

Bores [mm]		Size						
		01	0	1	2	3	4	
EAS®-side	d ^{4) 5)}	d _{min}	10	15	22	32	35	40
		d _{max}	20	25	35	45	55	65
ROBA®-ES-side	d ₃ ²⁾	d _{3 min}	15	19	20	28	35	45
		d _{3 max}	28	35	45	50	55	80
	d ₄ ²⁾	d _{4 min}	15	19	20	28	35 ⁶⁾	45
		d _{4 max}	28	38	45	50	60 ⁶⁾	75

We reserve the right to make dimensional and constructional alterations.

EAS®-Compact® overload lastic backlash-free

Type 494._24._

Sizes 01 to 4

EAS®-side key hub, ROBA®-ES-side key hub

Type 494._24._, Sizes 01 to 3

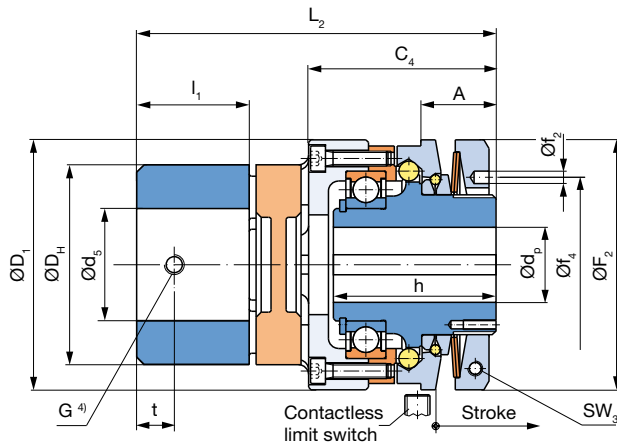

Type 494._24._, Size 4

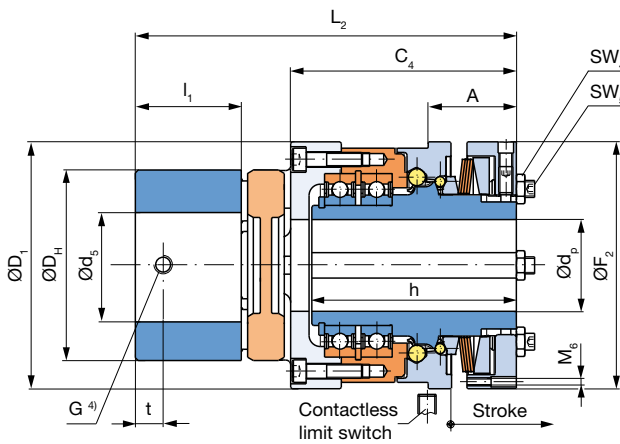

Order Number

EAS®-side Key hub	ROBA®-ES-side Key hub	2	4	Overload clutch	Torque adjustment value (Optional)
▾					
_ / 4 9 4 . _ 2 4 . _ / _ / _ / _ / _					
▲					
Sizes 01 to 4	Torque range ¹⁾ medium high very high maximum	5 6 7 8	Flexible coupling 92 Shore A 98 Shore A 64 Shore D	3 4 6	Hub 1 bore Ø d _p ^{H7} Hub 2 bore Ø d ₅ ^{H7} With limit switch see page 51 (Option)

Example: Order number 1 / 494.624.3 / 22 / 25 / 60 / limit switch 055.002.5

1) See Technical Data, limit torque for overload M_G

Technical Data				Size						
				01	0	1	2	3	4	
Limit torques for overload ¹⁾	Type 494.524._	M_G	[Nm]	5 – 12,5	10 – 25	20 – 50	40 – 100	80 – 200	120 – 300	
	Type 494.624._	M_G	[Nm]	10 – 25	20 – 50	40 – 100	80 – 200	160 – 400	240 – 600	
	Type 494.724._	M_G	[Nm]	20 – 50	40 – 100	80 – 200	160 – 400	320 – 800	480 – 1200	
	Type 494.824._	M_G	[Nm]	25 – 62,5	50 – 125	100 – 250	200 – 500	400 – 1000	600 – 1500	
Max. speed	n_{maxi}	[rpm]		8000	7000	6000	5000	4000	3500	
Thrust washer stroke on overload		[mm]		2,0	2,6	3,2	3,8	4,5	5,5	
Nominal and maximum torques ¹⁾ , flexible coupling	92 Shore A	$T_{KN}/T_{K max}$	[Nm]	35 / 70	95 / 190	190 / 380	265 / 530	310 / 620	900 / 1800	
	98 Shore A	$T_{KN}/T_{K max}$	[Nm]	60 / 120	160 / 320	325 / 650	450 / 900	525 / 1050	1040 / 2080	
	64 Shore D	$T_{KN}/T_{K max}$	[Nm]	75 / 150	200 / 400	405 / 810	560 / 1120	655 / 1310	1250 / 2500	
Permitted misalignments	axial	ΔK_a	[mm]	1,4	1,5	1,8	2,0	2,1	2,6	
	radial	92 Shore A	ΔK_r	[mm]	0,14	0,15	0,17	0,19	0,21	0,25
		98 Shore A	ΔK_r	[mm]	0,10	0,11	0,12	0,14	0,16	0,18
		64 Shore D	ΔK_r	[mm]	0,07	0,08	0,09	0,10	0,11	0,13
	angular	92 Shore A	ΔK_w	[°]	1,0	1,0	1,0	1,0	1,0	1,0
		98 Shore A	ΔK_w	[°]	0,9	0,9	0,9	0,9	0,9	0,9
	64 Shore D	ΔK_w	[°]	0,8	0,8	0,8	0,8	0,8	0,8	

Mass moments of inertia and weights				Size					
				01	0	1	2	3	4
EAS®-hub-side	Type 494._24._	I	[10 ⁻³ kgm ²]	0,377	0,917	2,193	4,205	9,867	37,215
ROBA®-ES-side	Type 494._24._	I	[10 ⁻³ kgm ²]	0,321	0,695	1,844	7,39	14,519	62,873
Weights	Type 494._24._	m	[kg]	1,23	1,92	3,26	6,73	10,28	27,19

Screws				Size					
				01	0	1	2	3	4
Locking screws in adjusting nut Sizes 01 - 3	Number, dimensions	M_3	[mm]	1 x M4	1 x M4	1 x M5	1 x M5	1 x M6	-
	Wrench opening	SW_3	[mm]	3	3	4	4	5	-
	Tightening torque	T_A	[Nm]	3	5	9	9	15	-
Pins/threads in adjusting nut Size 4	Wrench opening	SW_4	[mm]	-	-	-	-	-	18
	Wrench opening	SW_5	[mm]	-	-	-	-	-	6
	Number, dimensions	M_6	[mm]	-	-	-	-	-	3 x M8

Dimensions [mm]	Size					
	01	0	1	2	3	4
A	24	28	30	34	40	62,5
C ₄	52	63,5	75	82	94	160
D ₁	70	85	100	115	135	175
D _H	55	65	80	95	105	135
F ₂	70	85	100	115	135	175
f ₂	5	5	5	6	7	-
f ₄	50	55	70	84	100	-
G ⁴⁾	M5	M6	M8	M8	M8	M10
h	45	55	65	72	82	145
L ₂	100	118,5	144	158	178	270
l ₁	30	35	45	50	56	75
t	10	15	15	20	25	20

Bores [mm]		Size						
		01	0	1	2	3	4	
EAS® - side	d _p	d _{p min} ²⁾	12	15	22	28	32	40
		d _{p max} ³⁾	20	25	30	40	50	65
ROBA® - ES - side	d _s	d _{s min}	8	10	12	14	20	38
		d _{s max}	28	38	45	55	60	80

We reserve the right to make dimensional and constructional alterations.

- 1) The transmittable torques on the flexible coupling "T_{KN}" are dependent on factors such as temperature, torsional rigidity, etc., see also coupling dimensioning ROBA®-ES catalogue K.940.V_ _ or contact the manufacturer.
- 2) Smaller bores for low torques available on request
- 3) Larger bores available on request
- 4) Keyway 180° offset to "G"

Technical Data				Size
				5
Limit torques for overload	Type 494.5_4.2	M_G	[Nm]	240 – 600
	Type 494.6_4.2	M_G	[Nm]	480 – 1200
	Type 494.7_4.2	M_G	[Nm]	960 – 2400
	Type 494.8_4.2	M_G	[Nm]	1200 – 3000
Max. speed		n_{max}	[rpm]	3000
Thrust washer stroke on overload			[mm]	6,5
Nominal torques, flexible coupling	Type 494.5_4.2	T_{KN}	[Nm]	2400
	Type 494.6_4.2	T_{KN}	[Nm]	2400
	Type 494.7_4.2	T_{KN}	[Nm]	2400
	Type 494.8_4.2	T_{KN}	[Nm]	3700
Permitted misalignments ²⁾	axial	ΔK_a	[mm]	2,0
	radial	ΔK_r	[mm]	0,3
	angular	ΔK_w	[°]	0,07

Mass moments of inertia and weights				Size
				5
EAS®-hub side	Type 494._24.2	I	[10 ⁻³ kgm ²]	112,399
	Type 494._34.2	I	[10 ⁻³ kgm ²]	120,834
Lastic-side	Type 494._4.2	I	[10 ⁻³ kgm ²]	420,870
Weights	Type 494._24.2	m	[kg]	69,780
	Type 494._34.2	m	[kg]	70,150

Screws				Size
				5
In cone bushing EAS®-side	Number, dimensions	M	[mm]	8 x M10
	Wrench opening	SW	[mm]	16
	Tightening torque	T_A	[Nm]	71
Pins/threads in adjusting nut	Wrench opening	SW ₄	[mm]	18
	Wrench opening	SW ₅	[mm]	6
	Number, dimensions	M ₆	[mm]	3 x M8

Dimensions [mm]	Size
	5
A	80
A ₁	60
D	240
D ₁	146
E	215
F ₂	225
f	134
G	M12
g ₄	118
h	175
k ₁	6,4
L ¹⁾	193
L ₂	400
L ₃ ¹⁾	418
l	117
l ₁	75,5
l ₂	108
S	4
t	35

Bores [mm]			Size
			5
EAS®-side	d _p	d _{p min}	45
		d _{p max}	80
Lastic-side	d	d _{min}	45
		d _{max}	85
Lastic-side	d ₂	d _{2 min}	60
		d _{2 max}	100

We reserve the right to make dimensional and constructional alterations.

1) Dimensions in untightened condition (shorter in tightened condition)
 2) The values refer to 1500 rpm.

EAS®-Compact® Options

EAS®-Compact® with adjusting nut for radial torque adjustment

The EAS®-Compact® can be equipped with an adjusting nut for radial torque adjustment if the clutch cannot be accessed axially due to narrow installation conditions.

On this variant, the graduation scale for reading and adjusting the torque is mounted radially visible on the outer diameter.

Dimensions [mm]	Size				
	01	0	1	2	3
A ₂	12	13,5	16	17	20,5
F ₁	59	73	88	104	125
F ₂	70	85	100	115	135
X	6	7	7	8	10
x	3	4	4	4,5	4

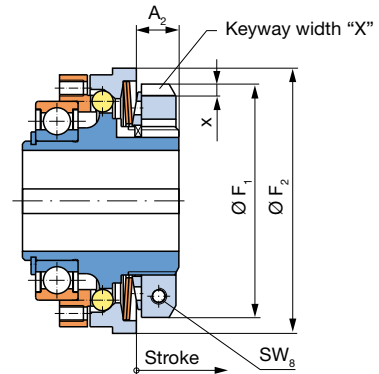

EAS®-Compact® with clamping ring

EAS®-Compact® clutches with clamping ring hubs can be mounted extremely quickly and easily onto the shaft. The slotted clamping ring is tensioned using one single screw. Due to the equipment with an adjusting nut for radial torque adjustment, the limit torque for overload can be altered even in installed condition.

Dimensions [mm]	Size				
	01	0	1	2	3
A ₃	15,5	19	20,5	23,5	26
F ₂	70	85	100	115	135
F ₃	60	72	84	97	115
L ₄	43,5	53,5	63,5	70,5	80,5
L ₅	65	77	90	103	117
I ₄	18	22	26	32	36

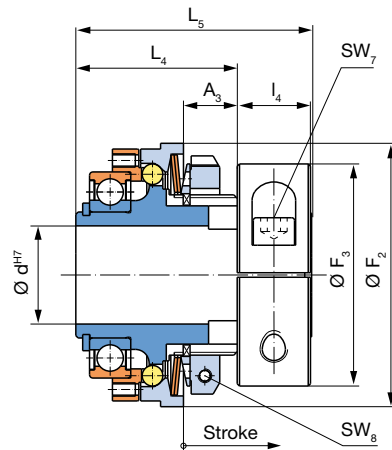

Bores [mm]		Size				
d ^{H7}	d _{min}	01	0	1	2	3
		d _{max}	25 ¹⁾	32 ²⁾	40 ³⁾	45 ⁴⁾

- 1) On bores Ø 10 – 14 set limit torque for overload M_G = 70 %
- 2) On bores Ø 15 – 19 set limit torque for overload M_G = 70 %
- 3) On bores Ø 22 – 29 set limit torque for overload M_G = 70 %
- 4) On bores Ø 32 – 40 set limit torque for overload M_G = 70 %
- 5) On bores Ø 35 – 45 set limit torque for overload M_G = 70 %

EAS®-Compact® torsionally rigid Modular Structure

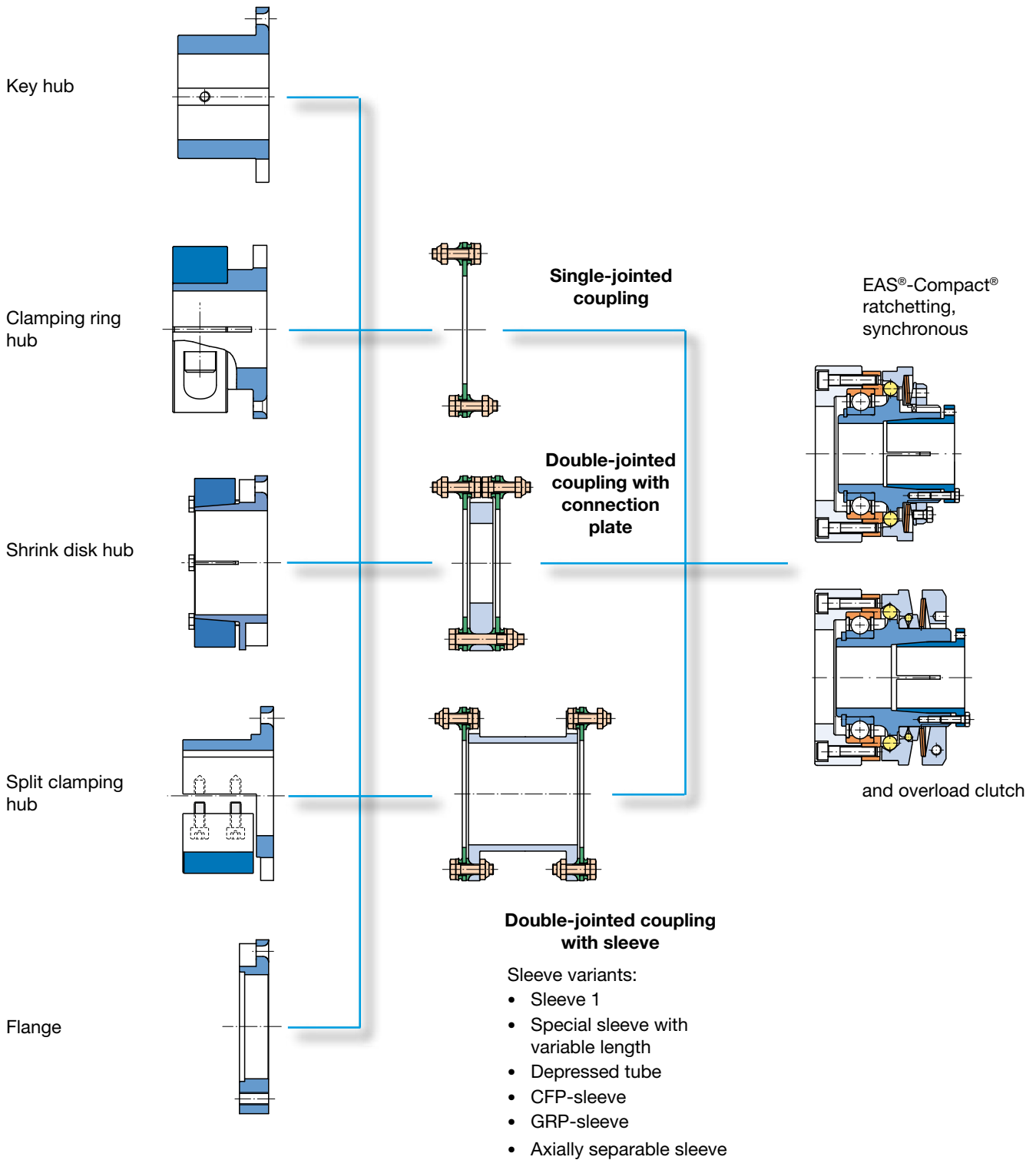

EAS®-Compact® ratchetting, synchronous and overload clutches can be combined with almost all components of the ROBA®-DS backlash-free shaft coupling. For a current selection of different Types, please see pages 16 and 17 as well as pages 32 and 35.

We are happy to assist you in dimensioning and assembling your optimum clutch.

Readable Torque Adjustment

The EAS®-Compact® overload clutch offers easily readable torque adjustment on the adjusting nut (for sizes 01 to 3). This readability makes adjusting the torque far more simple, and also allows easy checks on the set release value on the installed clutch.

- The limit torque can be finely adjusted and accurately read due to the adjusting nut with the fine thread and the easily-readable graduation scale.
- The positive-locking (or frictionally-locking) safeguard on the adjusting nut protects against self-turning, inadvertent adjustment of the set limit torque. The integral blocking protection prevents the cup springs from becoming spring-bound.

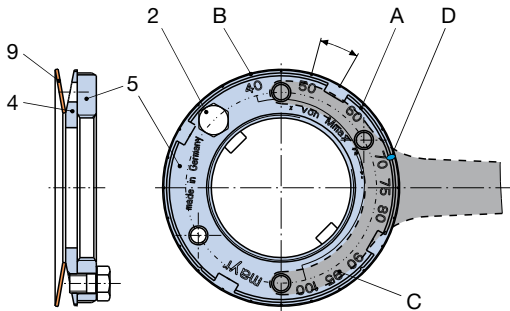

Fig. 1: EAS®-Compact® ratchetting and synchronous clutch

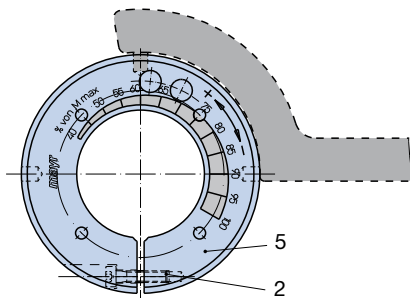

Fig. 2: EAS®-Compact® overload clutch

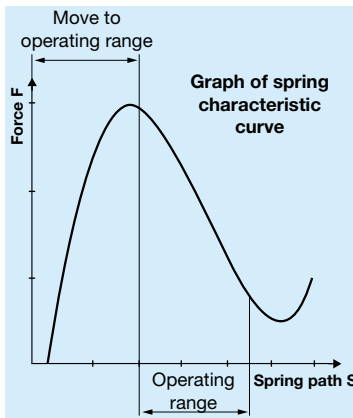

Fig. 3 (The diagram only serves as an example)

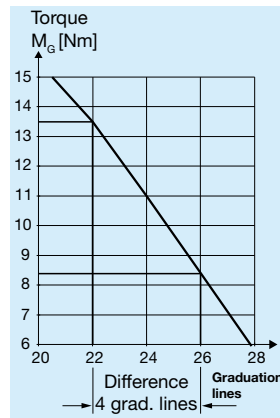

Fig. 4 (The diagram only serves as an example)

i Depending on the drive and the drive constellation, torque peaks (e.g. via start-up torque impacts on asynchronous motors) can occur which lie substantially above the system (motor) operating torque. This behaviour is to be taken into account customer-side when dimensioning or adjusting the clutch.

Torque Adjustment

Adjustment takes place by turning the adjusting nut (5) (sizes 03 to 3) or the set screws (6) (sizes 4 and 5).

The installed cup springs (9) are operated in the negative range of the characteristic curve (Fig. 3). A stronger pre-tension produces a decrease in spring force. Turning the adjusting nut (5) (sizes 03 to 3) or the set screws (6) (sizes 4 and 5) clockwise therefore produces a decrease in spring force. Turning it anti-clockwise produces an increase in torque (facing direction towards the adjusting nut (5) – Figs. 1 and 2).

If no other torque adjustment is requested customer-side, the **EAS®-Compact® ratchetting, synchronous and overload clutch** is **generally** set and marked (calibrated) manufacturer-side to c. 70 % of the respective maximum torque. The respective torque adjustment or the adjustable torque range are visible on the Type tag.

A control “spring application in the operating range” can be carried out via the dimension “a”.

- EAS®-Compact® ratchetting and synchronous clutch (sizes 01-3): Dimension “a” is the distance between the adjusting nut facing side (5) to the pressure plate facing side (3) (Fig. 5).
- EAS®-Compact® overload clutch (sizes 01-3): Dimension “a” is the distance between the adjusting nut facing side (5) to the hub edge (1) (Fig. 6).

For the corresponding data, please see the Installation and Operational Instructions.

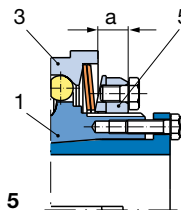

Fig. 5

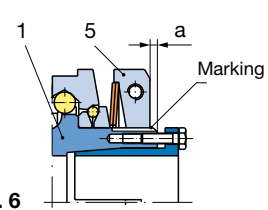

Fig. 6

EAS®-NC sizes 03 and 02 must be adjusted according to the Adjustment Diagram (please order if necessary) if no adjustment or calibration was made manufacturer-side.

EAS®-NC size 03 (Fig. 7):

- Unscrew both set screws (8) from the adjusting nut (5).
- Grease the thread surfaces on the adjusting nut (5) and the hub (1).
- Set the adjusting nut (5) to the required dimension “a” (acc. Adjustment Diagram) using a hook wrench.
- Paint both set screws (8) with Loctite 243, screw them into the adjusting nut (5) and tighten them.

EAS®-NC size 02 (Fig. 8 and Fig. 4):

- Loosen the locking screw (2).
- Grease the contact surfaces on the adjusting nut (5), the locking ring (4) and the hub (1).
- Set the adjusting nut (5) by hand to the contact on the cup spring (9).
- Continue to turn until the four notches on the circumference of the adjusting nut (5) and the notches in the locking ring (4) align.
- Turn the adjusting nut (5) further using a face wrench to the number of graduation lines which equal the required torque (Fig. 4, number of graduation lines in the Adjustment Diagram). The 4 notches on the circumference of the adjusting nut (5) and on the locking ring (4) must be in the same position.
- Paint the locking screw (2) with Loctite 243 and screw it into the adjusting nut (5).

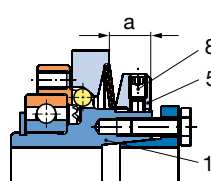

Fig. 7

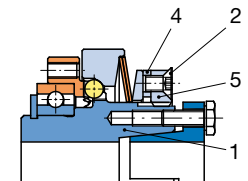

Fig. 8

Torque Adjustment

Sizes 01 to 3 (Figs. 1, 2 and 6):

- Convert the required torque (acc. formula below) in percent of the max. adjustment value:

$$\frac{\text{Required torque}}{\text{Max. torque adjustment (see Table Technical Data)}} \times 100 = \text{Adjustment \%}$$

- Loosen the locking screw (2) in the adjusting nut (5).
- Turn the adjusting nut (5) clockwise or anti-clockwise according to the engraved adjustment scale (Figs. 1 and 2) using a hook wrench or a face wrench, until the required torque is set.
- The required torque results from:
 - the locking ring (4) marking (D) overlap and the percent value (C) on the adjusting nut (5) (ratchetting and synchronous clutch, Fig. 1), or
 - the hub (1) marking overlap and the percent value on the adjusting nut (5) (overload clutch, Figs. 2 and 6).
- Paint the locking screw (2) with Loctite 243 and screw it into the adjusting nut (5); the 4 notches (A) in the adjusting nut (5) and the notches (B) in the locking ring (4) must be in the same position (Fig. 1). Correct slightly if necessary.

Example:

EAS®-Compact® size 3, Type 490.610.0 (M_G max. = 350 Nm):
Torque pre-adjustment = 70 % of M_G max. = 245 Nm.
The adjustment should be increased from 245 Nm to 280 Nm.

- Define the torque adjustment in percent of M_G max. using the formula below:

$$\frac{280}{350} \times 100 = 80 \%$$

- Turn the adjusting nut (5) according to the facing-side scale (Fig. 1) **anti-clockwise** from 70 % to 80 % on the adjustment scale using a face wrench.

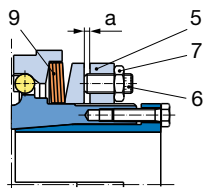

Fig. 9

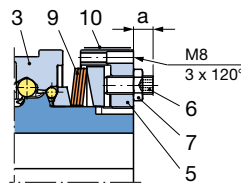

Fig. 10

Sizes 4 and 5 (Figs. 9 and 10):

Adjustment only takes place by turning the set screws (6) and not by turning the adjusting nut (5):

- Loosen all hexagon nuts (7).
- Tighten all set screws (6) evenly using an Allen wrench to the required dimension "a".
 - EAS®-Compact® ratchetting and synchronous clutch, size 4: find dimension "a" in the Adjustment Table glued to the clutch (Fig. 9).
 - EAS®-Compact® overload clutch, sizes 4-5: find dimension "a" in the Adjustment Table glued to the adjusting nut (5) (Fig. 10).
- Counter the set screws (6) again using hexagon nuts (7).



After clutch disassembly (e.g. due to cup spring or cup spring layering replacement), the clutch must be re-set!

Re-engagement of the EAS®-Compact® overload clutch

EAS®-Compact® overload clutch re-engagement is carried out by applying axial pressure to the thrust washer (3). It may be necessary to turn slightly between the clutch input and output sides.



Re-engagement must only take place when the device is not running or at low differential speeds (< 10 rpm). For a more detailed explanation on re-engagement, please see the respective Installation and Operational Instructions.

Depending on the application possibilities, the ease of entrance at the installation point etc., re-engagement can take place in different ways:

Sizes 01 to 3:

- Manually, e.g. using a plastic hammer or installation levers supported on the adjusting nut (5) (e.g. 2 screwdrivers placed opposite each other).
- By using an engagement mechanism.
The engagement procedure can also be automated using pneumatic or hydraulic cylinders.

Sizes 4 and 5:

- By evenly screwing 3 hexagon head screws M8 (provided by the user) into the adjusting nut (5) (Fig. 10).



After re-engagement has taken place, the three hexagon head screws must be removed immediately, as they could stop the clutch functioning (blockage).

- By using two screwdrivers, applied opposite each other and supported by the cup springs (9).
- By using an engagement mechanism.
The engagement procedure can also be automated using pneumatic or hydraulic cylinders.

Permitted Bearing Load

The output element is centred on the deep groove ball bearing (tolerance H7/h5) and screwed together with the pressure flange (3).

If the resulting radial force from the output element is anywhere near the centre of the ball bearing and under the maximum permitted radial load according to Table 1, an additional bearing for the output element is unnecessary.

No appreciable axial forces (see Table 1) should be transferred from the output element onto the clutch pressure flange (3).

Permitted bearing load		Size								
		03	02	01	0	1	2	3	4	5
Axial forces	F_A [kN]	0,12	0,28	0,65	1	1,5	2,4	4,2	5	7,7
Radial forces	F_R [kN]									
1-bearing design		0,1	0,25	0,65	1	1,5	2,4	4,2	5	-
2-bearing design		0,15	0,375	1	1,5	2,25	3,6	6,3	7,5	11,5
Transverse force torques*	M_G [Nm]	0,5	1,5	5	10	20	30	40	50	70

Table 1

* Torques, which put strain on the deep groove ball bearing due to the non-centric axial forces having an effect on the pressure flange.

Size Selection, Energy Calculation, Torque Adjustment for Horizontal Servo Axes

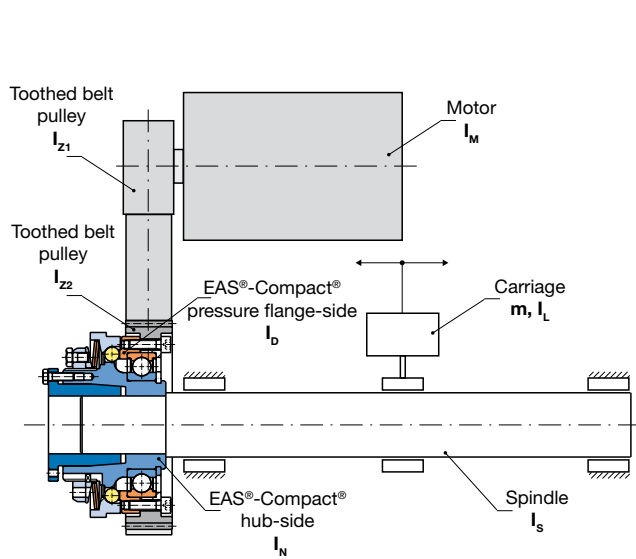

Fig. 1

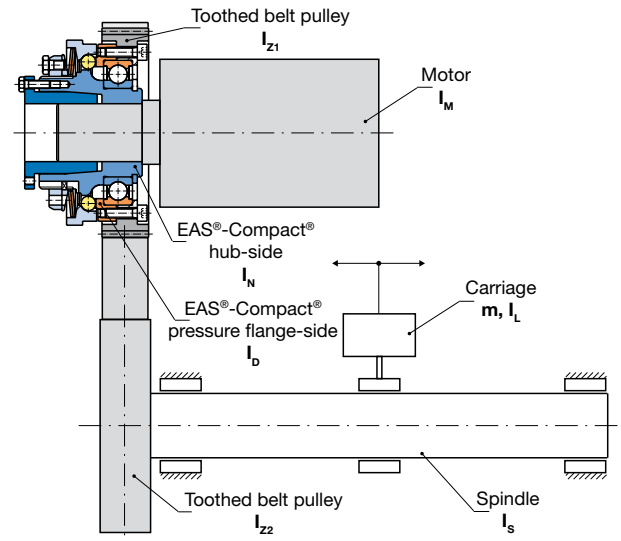

Fig. 2

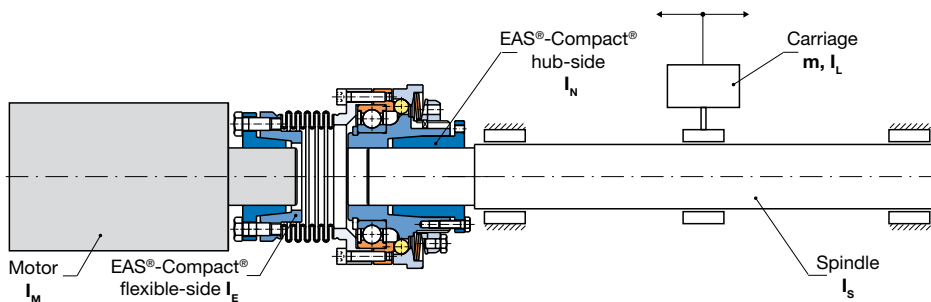
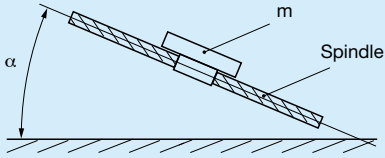

Fig. 3

Configuration Fig. 1	Configuration Fig. 2	Configuration Fig. 3
Total mass moment of inertia without EAS®-Compact® clutch		
$I_g = I_M + I_{z1} + (I_{z2} + I_s + I_L) \cdot \left(\frac{n_2}{n_1}\right)^2$ $I_L \text{ from equation (7)}$	$I_g = I_M + I_{z1} + (I_{z2} + I_s + I_L) \cdot \left(\frac{n_2}{n_1}\right)^2$ $I_L \text{ from equation (7)}$	$I_g = I_M + I_{ku} + I_s + I_L$ $I_L \text{ from equation (7)}$
Mass moment of inertia input-side with reference to the shaft with EAS®-Compact® clutch		
$I_1 = I_b + I_{z2} + (I_{z1} + I_M) \cdot \left(\frac{n_1}{n_2}\right)^2$	$I_1 = I_M + I_N$	$I_1 = I_M + I_E$
Mass moment of inertia output-side (spindle-side) with reference to the shaft with EAS®-Compact® clutch		
$I_2 = I_N + I_s + I_L$ $I_L \text{ from equation (7)}$	$I_2 = I_b + I_{z1} + (I_{z2} + I_s + I_L) \cdot \left(\frac{n_2}{n_1}\right)^2$ $I_L \text{ from equation (7)}$	$I_2 = I_N + I_s + I_L$ $I_L \text{ from equation (7)}$
Clutch pre-selection		
$M_{req.} = 1,5 \cdot M_2$ $M_2 \text{ from equation (4)}$	$M_{req.} = 1,5 \cdot M_1$	$M_{req.} = 1,5 \cdot M_1$

Configuration Fig. 1	Configuration Fig. 2	Configuration Fig. 3	
Torque on the spindle			
$M_2 = M_1 \cdot \frac{n_1}{n_2}$	As configuration Fig. 1	As configuration Fig. 1	[Nm] (4)
Carriage feed drive speed			
$v = \frac{p \cdot n_2}{6 \cdot 10^4}$	As configuration Fig. 1	As configuration Fig. 1	$\left[\frac{m}{s}\right]$ (5)
Angular speed of the motor shaft ω_1 and the spindle ω_2			
$\omega_1 = \frac{n_1 \cdot \pi}{30}$ $\omega_2 = \frac{n_2 \cdot \pi}{30}$	As configuration Fig. 1	As configuration Fig. 1	[s ⁻¹] (6)
Mass of the carriage reduced on the spindle			
$I_L = m \cdot \frac{v^2}{\omega_2^2}$ v from equation (5), ω_2 from equation (6)	As configuration Fig. 1	As configuration Fig. 1	[kgm ²] (7)
Energy on collision without EAS®-Compact® clutch			
$W_g = \frac{1}{2} \cdot I_g \cdot \omega_1^2$ I_g from equation (1), ω_1 from equation (6)	As configuration Fig. 1	As configuration Fig. 1	[J] (8)
Energy on collision with EAS®-Compact® clutch			
$W_2 = \frac{1}{2} \cdot I_2 \cdot \omega_2^2$ I_2 from equation (3), ω_2 from equation (6)	$W_2 = \frac{1}{2} \cdot I_2 \cdot \omega_1^2$ I_2 from equation (3), ω_1 from equation (6)	$W_2 = \frac{1}{2} \cdot I_2 \cdot \omega_1^2$ I_2 from equation (3), ω_1 from eq. (6)	[J] (9)
Remaining residual energy			
$W_R = \frac{W_2}{W_g} \cdot 100$ W_g from equation (8), W_2 from equation (9)	As configuration Fig. 1	As configuration Fig. 1	[%] (10)
Uncoupled energy			
$\Delta W = W_g - W_2$	As configuration Fig. 1	As configuration Fig. 1	[J] (11)
$\Delta W = 100 - W_R$ W_g from equation (8), W_2 from equation (9), W_R from equation (10)			[%] (12)
Required disengagement torque in the acceleration phase (horizontal axis)			
$M_A = M_B \cdot \frac{I_2}{I_2 + I_1} \cdot \frac{n_1}{n_2}$ I_1 from equation (2), I_2 from equation (3)	Speed ratio $\frac{n_1}{n_2}$ not applicable.	Speed ratio $\frac{n_1}{n_2}$ not applicable.	[Nm] (13)
Required disengagement torque in the acceleration phase torque (axis in any direction)			
$M_A = [(M_B \cdot \frac{n_1}{n_2} - M_L) \cdot \frac{I_2}{I_2 + I_1} + M_L] \times 1,2$ M_L from equation (15)	$M_A = [(M_B - M_L \cdot \frac{n_2}{n_1}) \cdot \frac{I_2}{I_2 + I_1} + M_L \cdot \frac{n_2}{n_1}] \times 1,2$ M_L from equation (15)	$M_A = [(M_B - M_L) \cdot \frac{I_2}{I_2 + I_1} + M_L] \times 1,2$ M_L from equation (15)	[Nm] (14)
Load torque from carriage mass in any direction			
$M_L = \frac{m \cdot g \cdot \sin \alpha \cdot p}{2 \cdot \pi \cdot 1000}$ 	As configuration Fig. 1	As configuration Fig. 1	[Nm] (15)
Limit torque adjustment			
$M_G = 1,5 \cdot M_2$ M_2 from equation (4)	$M_G = 1,5 \cdot M_1$	$M_G = 1,5 \cdot M_2$ M_2 from equation (4)	[Nm] (16)
Condition: The disengagement torque M_A from equation (13) or (14) (multiplied by a factor of 1,2) must be smaller than the torque M_G set on the clutch.			

Calculation Example

Configuration as shown in Fig. 1

Indications:

Mass of the carriage	m	= 560 kg
Mass moment of inertia of the motor	I_M	= 0,0037 kgm ²
Mass moment of inertia of the toothed belt pulleys	I_{Z1}	= 0,0006 kgm ²
	I_{Z2}	= 0,01132 kgm ²
Mass moment of inertia of the spindle	I_S	= 0,00067 kgm ²
Drive speed of the motor	n_1	= 2000 rpm
Speed of the spindle	n_2	= 1000 rpm
Pitch of the spindle	p	= 10 mm
Nominal torque of the motor	M_1	= 14 Nm
Max. torque of the motor	M_B	= 40 Nm

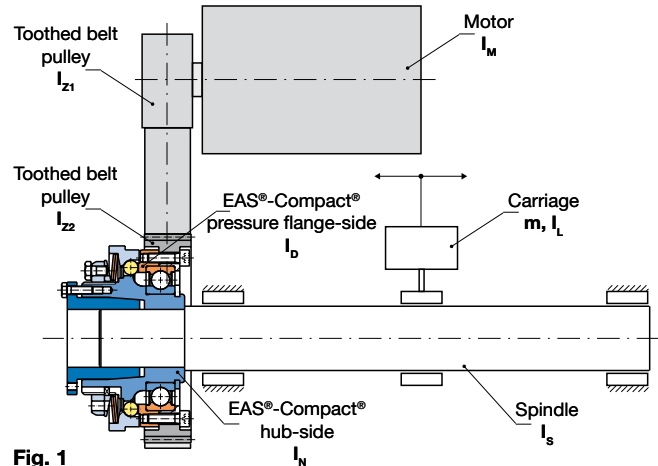

Fig. 1

Pre-selection of the clutch

$$M_{req.} = 1,5 \cdot M_2 \quad M_{req.} = 1,5 \cdot 28 = 42 \quad [\text{Nm}]$$

M_2 from equation (4)

Selected: EAS®-Compact® size 0, Type 490.610.0
 Torque range $M_G = 20 \div 50 \text{ Nm}$
 (see Technical Data, page 9)

Total mass moment of inertia of the EAS®-Compact®

Hub side $I_N = 0,000531 \text{ kgm}^2$ (see Techn. Data. page 9)
 Pressure flange side $I_b = 0,000234 \text{ kgm}^2$ (see Techn. Data, page 9)

Mass moment of inertia without EAS®-Compact® clutch

$$I_g = I_M + I_{Z1} + (I_{Z2} + I_S + I_L) \cdot \left(\frac{n_2}{n_1}\right)^2 \quad I_L \text{ from equation (7)}$$

$$I_g = 0,0037 + 0,0006 + (0,01132 + 0,00067 + 0,00142) \cdot \left(\frac{2000}{1000}\right)^2$$

$$I_g = 0,00765 \quad [\text{kgm}^2] \quad (1)$$

Mass moment of inertia input-side referring to the shaft with the EAS®-Compact® clutch

$$I_1 = I_b + I_{Z2} + (I_{Z1} + I_M) \cdot \left(\frac{n_1}{n_2}\right)^2$$

$$I_1 = 0,000234 + 0,01132 + (0,006 + 0,0037) \cdot \left(\frac{2000}{1000}\right)^2$$

$$I_1 = 0,0287 \quad [\text{kgm}^2] \quad (2)$$

Mass moment of inertia output-side (spindle-side) corresponding to the shaft with the EAS®-Compact® clutch

$$I_2 = I_N + I_S + I_L \quad I_L \text{ from equation (7)}$$

$$I_2 = 0,000531 + 0,00067 + 0,00142 = 0,00262 \quad [\text{kgm}^2] \quad (3)$$

Torque on the spindle

$$M_2 = M_1 \cdot \frac{n_1}{n_2} = 14 \cdot \frac{2000}{1000} = 28 \quad [\text{Nm}] \quad (4)$$

Carriage feed rate

$$v = \frac{p \cdot n_2}{6 \cdot 10^4} = \frac{10 \cdot 1000}{6 \cdot 10^4} = 0,1667 \quad \left[\frac{\text{m}}{\text{s}}\right] \quad (5)$$

Angular velocity of the motor shaft ω_1 and the spindle ω_2

$$\omega_1 = \frac{n_1 \cdot \pi}{30} = \frac{2000 \cdot \pi}{30} = 209 \quad [\text{s}^{-1}] \quad (6)$$

$$\omega_2 = \frac{n_2 \cdot \pi}{30} = \frac{1000 \cdot \pi}{30} = 104,7 \quad [\text{s}^{-1}] \quad (6)$$

Mass of the carriage reduced on the spindle

$$I_L = m \cdot \frac{v^2}{\omega_2^2} = 560 \cdot \frac{0,1667^2}{104,7^2} = 0,00142 \quad [\text{kgm}^2] \quad (7)$$

v from equation (5), ω_2 from equation (6)

Energy on collision without EAS®-Compact® clutch

$$W_g = \frac{1}{2} \cdot I_g \cdot \omega_1^2 = \frac{1}{2} \cdot 0,00765 \cdot 209^2 = 167 \quad [\text{J}] \quad (8)$$

I_g from equation (1), ω_1 from equation (6)

Energy on collision with EAS®-Compact® clutch

$$W_2 = \frac{1}{2} \cdot I_2 \cdot \omega_2^2 = \frac{1}{2} \cdot 0,00262 \cdot 104,7^2 = 14 \quad [\text{J}] \quad (9)$$

I_2 from equation (3), ω_2 from equation (6)

Remaining residual energy

$$W_R = \frac{W_2}{W_g} \cdot 100 = \frac{14}{167} \cdot 100 = 8,4 \quad [\%] \quad (10)$$

W_g from equation (8), W_2 from equation (9)

Uncoupled energy

$$\Delta W = W_g - W_2 = 167 - 14 = 153 \quad [\text{J}] \quad (11)$$

$$\Delta W = 100 - W_R = 100 - 8,4 = 91,6 \quad [\%] \quad (12)$$

Required disengagement torque in the acceleration phase (horizontal axis)

$$M_A = M_B \cdot \frac{I_2}{I_2 + I_1} \cdot \frac{n_1}{n_2} \quad I_1 \text{ from equation (2)}$$

$$M_A = 40 \cdot \frac{0,00262}{0,00262 + 0,0287} \cdot \frac{2000}{1000} = 6,7 \quad [\text{Nm}] \quad (13)$$

Limit torque adjustment

$$M_G = 1,5 \cdot M_2 = 1,5 \cdot 28 = 42 \quad [\text{Nm}] \quad (16)$$

Condition: The disengagement torque $1,2 \cdot M_A = 1,2 \cdot 6,7 = 8,04 \text{ Nm}$ is smaller than the torque $M_G = 42 \text{ Nm}$ set on the clutch.

Classifications:

I_g	[kgm ²]	Total mass moment of inertia without EAS [®] -Compact [®] clutch
I_1	[kgm ²]	Mass moment of inertia input-side corresponding to the shaft with the EAS [®] -Compact [®] clutch
I_2	[kgm ²]	Mass moment of inertia output-side (spindle-side) referring to the shaft with the EAS [®] -Compact [®] clutch
I_M	[kgm ²]	Mass moment of inertia of the motor
I_{Z1}	[kgm ²]	Mass moment of inertia of the motor-side toothed belt pulley
I_{Z2}	[kgm ²]	Mass moment of inertia of the second toothed belt pulley
I_S	[kgm ²]	Mass moment of inertia of the spindle
I_L	[kgm ²]	Mass of the carriage reduced on the spindle
I_N	[kgm ²]	Mass moment of inertia of the EAS [®] -Compact [®] , hub-side
I_D	[kgm ²]	Mass moment of inertia of the EAS [®] -Compact [®] , pressure flange-side
I_E	[kgm ²]	Mass moment of inertia of the EAS [®] -Compact [®] , flexible coupling
I_{Ku}	[kgm ²]	Mass moment of inertia of the double shaft connection before installation of the EAS [®] -Compact [®] clutch
M_1	[Nm]	Motor nominal torque
M_2	[Nm]	Torque on the spindle
M_A	[Nm]	Required disengagement torque in the acceleration phase
M_B	[Nm]	Maximum motor torque
M_G	[Nm]	Limit torques for overload
M_L	[Nm]	Load torque from the carriage mass in any direction
$M_{req.}$	[Nm]	Required torque (pre-selection of the clutch)
g	[m.s ⁻²]	Drop acceleration
m	[kg]	Carriage mass
n_1	[rpm]	Drive speed on the motor (rapid movement)
n_2	[rpm]	Spindle speed (rapid movement)
p	[mm]	Spindle pitch
v	[m.s ⁻¹]	Carriage feed rate
W_g	[J]	Total energy on collision without EAS [®] -Compact [®] clutch
W_2	[J]	Energy on collision with EAS [®] -Compact [®] clutch
W_R	[%]	Remaining residual energy
ΔW	[J]	Uncoupled energy
ΔW	[%]	Uncoupled energy
ω_1	[s ⁻¹]	Angular speed of the motor shaft
ω_2	[s ⁻¹]	Angular speed of the spindle

Table 1: Assignment of the bore diameters d_3/d_4 on the flexible coupling to the transmittable torque “ T_R “ EAS®-Compact® synchronous, ratchetting and overload clutches Types 494_0_./494_1_.

		Bore	Size						
			01	0	1	2	3	4	
Frictionally locking transmittable torques	Clamping hub $\varnothing d_3$ Valid for F7/k6	$\varnothing 15$	d_3	34	-	-	-	-	-
			d_4	56	-	-	-	-	-
		$\varnothing 16$	d_3	36	-	-	-	-	-
			d_4	62	-	-	-	-	-
		$\varnothing 19$	d_3	43	79	-	-	-	-
			d_4	81	141	-	-	-	-
		$\varnothing 20$	d_3	45	83	83	-	-	-
			d_4	87	153	197	-	-	-
		$\varnothing 22$	d_3	50	91	91	-	-	-
			d_4	100	177	228	-	-	-
		$\varnothing 24$	d_3	54	100	100	-	-	-
			d_4	120	203	261	-	-	-
		$\varnothing 25$	d_3	57	104	104	-	-	-
			d_4	125	216	279	-	-	-
		$\varnothing 28$	d_3	63	116	116	208	-	-
			d_4	135	256	332	300	-	-
		$\varnothing 30$	d_3	-	124	124	228	-	-
			d_4	-	282	368	350	-	-
		$\varnothing 32$	d_3	-	133	133	248	-	-
			d_4	-	308	405	400	-	-
		$\varnothing 35$	d_3	-	145	145	280	350	-
			d_4	-	343	460	500	450	-
		$\varnothing 38$	d_3	-	-	158	315	390	-
			d_4	-	-	373	513	500	-
		$\varnothing 40$	d_3	-	-	166	340	420	-
			d_4	-	-	547	680	600	-
		$\varnothing 42$	d_3	-	-	174	365	455	-
			d_4	-	-	577	730	720	-
		$\varnothing 45$	d_3	-	-	187	404	505	545
			d_4	-	-	617	790	850	1402
		$\varnothing 48$	d_3	-	-	-	442	560	590
			d_4	-	-	-	850	1000	1596
		$\varnothing 50$	d_3	-	-	-	470	600	630
			d_4	-	-	-	880	1180	1731
		$\varnothing 52$	d_3	-	-	-	-	640	662
			d_4	-	-	-	-	1270	1873
		$\varnothing 55$	d_3	-	-	-	-	705	710
			d_4	-	-	-	-	1353	2095
		$\varnothing 58$	d_3	-	-	-	-	-	764
			d_4	-	-	-	-	1428	2308
$\varnothing 60$	d_3	-	-	-	-	-	800		
	d_4	-	-	-	-	1471	2420		
$\varnothing 62$	d_3	-	-	-	-	-	840		
	d_4	-	-	-	-	-	2570		
$\varnothing 65$	d_3	-	-	-	-	-	900		
	d_4	-	-	-	-	-	2750		
$\varnothing 68$	d_3	-	-	-	-	-	954		
	d_4	-	-	-	-	-	2989		
$\varnothing 70$	d_3	-	-	-	-	-	990		
	d_4	-	-	-	-	-	3157		
$\varnothing 72$	d_3	-	-	-	-	-	1032		
	d_4	-	-	-	-	-	3306		
$\varnothing 75$	d_3	-	-	-	-	-	1095		
	d_4	-	-	-	-	-	3550		
$\varnothing 78$	d_3	-	-	-	-	-	1158		
	d_4	-	-	-	-	-	-		
$\varnothing 80$	d_3	-	-	-	-	-	1200		
	d_4	-	-	-	-	-	-		

Frictionally locking transmittable torques

Clamping hub $\varnothing d_3$
Valid for F7/k6

Shrink disk hub $\varnothing d_4$
Valid for H7/k6

The transmittable torques of the clamping connection take the max. tolerance backlash of the shaft tolerance k6/ bores F7 or H7 into account.

On larger tolerance backlash, the torque decreases.

T_R [Nm]

Limit Switch



Limit Switch Type 055.00_.5 (Contactless)

Application

This device is used for measuring and monitoring axial and radial disengaging movements, e.g. on EAS®-clutches. It acts as a control sensor for electronic and mechanical sequences.

Function

When the sensor surface of the NAMUR sensor scans a metal control flag (damped), the signal relay is triggered, is deenergised and drops. Contacts 1 - 2 are opened. Damping is possible from all sides.

Electrical Connection (Terminal)

1 – 2 – 3 Floating changeover contacts
5 – 6 Connection input voltage

Design

The electronic amplifier is installed in a light metal housing. The limit switch is fixed using two screw-on mounting links attached diagonally with M4 cap screws.

Technical Data

Input voltage (dependent on design)	230 VAC, ±10 %, 50 – 60 Hz 115 VAC, ±10 %, 50 – 60 Hz 24 VDC, PELV, ±5 %, protected against reverse polarity, for overvoltage category II connection
Power consumption	max. 1,5 VA
Ambient temperature	-10 °C up to +60 °C limit switch -25 °C up to +60 °C NAMUR sensor
Protection	IP54
Conductor cross-section	max. 2,5 mm ² / AWG 14
Weight	400 g / 14 oz
Protection fuse	0,1 A/ fast acting at 24 VDC (in system)
Signalling relay	Floating changeover contacts Contact load max. 250 VAC / 12 A Contact material AgNi 90/10 max. switching frequency 20 Hz at min. load, 0,1 Hz at max. load
NAMUR sensor internal	Installed in a light metal housing, switching distance S_s 2 mm, flush fitting, max. switching frequency 2 kHz, the zero point can be set per 1 mm by means of the lateral adjusting screw SW 7
NAMUR sensor external	metal housing M12 x 1, switching distance S_s 2 mm, flush fitting, max. switching frequency 2 kHz, standard cable length 2 m, max. 100 m with special design, protection IP67

Installation

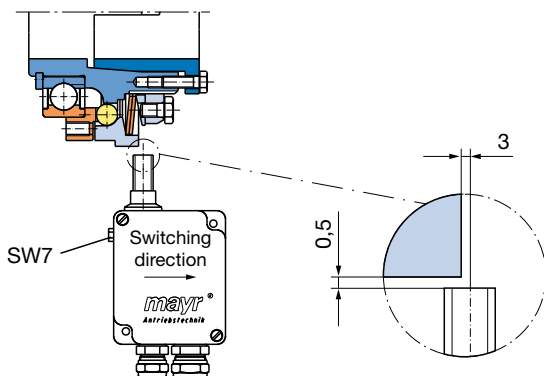

Dimensions (internal NAMUR sensor)

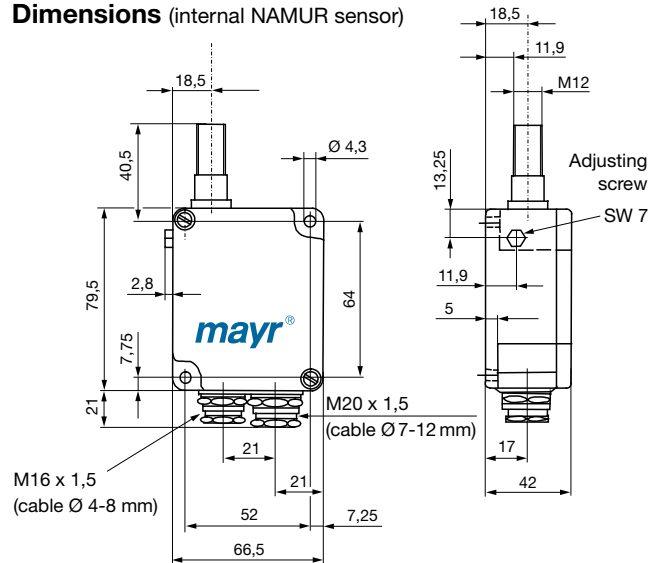

Dimensions (external NAMUR sensor)

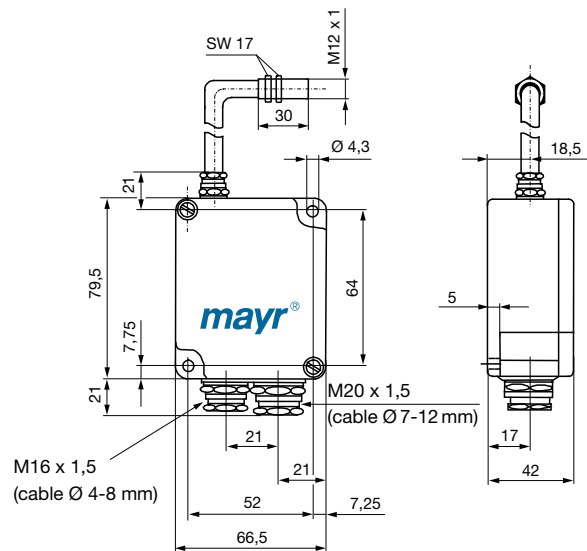

Order Number

0 5 5 . 0 0 _ . 5 / _

Contactless sensing		Connection voltage	
Sensor external	1	230 VAC	
Sensor internal	2	115 VAC	
		24 VDC	

Limit Switch Type 055.000.5 (Mechanical Operation)



Application

This device is used to monitor mechanical movements and end positions. It is a controlling sensor for electronic and mechanical sequences. It also registers axial disengaging movements, e.g. on EAS®-clutches.

Function

The pre-tensioned contact is discharged by actuating the switching lever:
 Contacts 11 – 14 (21 – 24) open, contacts 11 – 12 (21 – 22) close.

Design

The microswitch is fitted into a light metal housing and is actuated by a switching lever. Operation is only possible in one direction. The limit switch is fixed using M4 cap screws via two screw-on mounting links attached diagonally.



Technical Data

Contact	1 changeover contact (special design: 2 changeover contacts)
Switching capacity	250 VAC / 15 A (with 2 contacts: 10 A) 24 VDC / 6 A 60 VDC / 1,5 A 250 VDC / 0,2 A min. 12 VDC / 10 mA
Contact material	AgCdO 90/10
Switching frequency	Max. 200 switching operations/min
Ambient temperature	-10 °C up to +85 °C
Protection	IP54
Weight	275 g
Switching travel setting	Using the adjusting screw (SW 7), the zero point can be moved right or left by max. 5 mm
Switching travel	Pretravel: min. 0,15 to 0,5 mm Overtravel: max. 10 mm, depending on the zero point setting
Special types	Different switching lever lengths as well as a design with 2 changeover contacts are possible on request

Dimensions (mm)

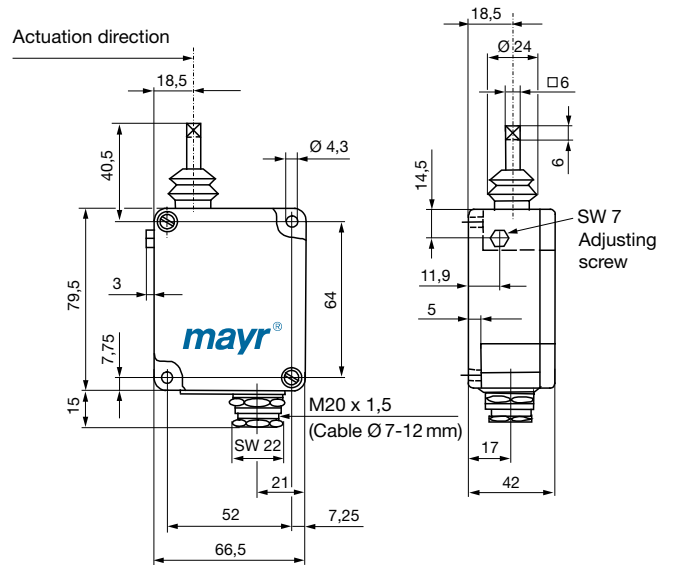

Installation

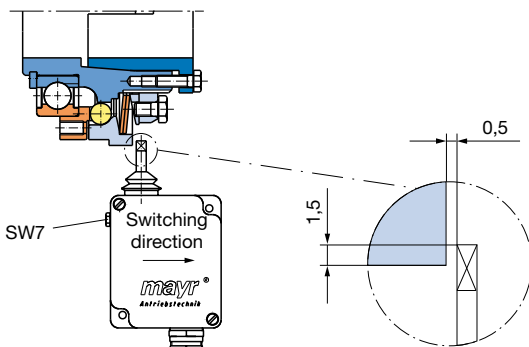

Electrical Connection

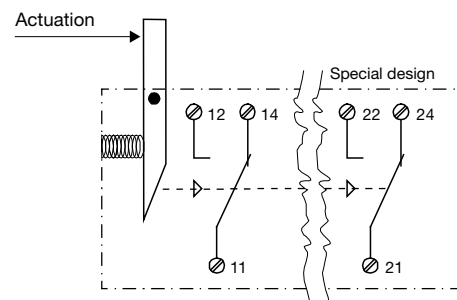

Order Number

0 5 5 . 0 0 0 . 5

Limit Switch Type 055.010.6 (Mechanical Operation, Multi-directional)

Application

The limit switch is used to monitor and measure axial or radial mechanical movements and adjustments e.g. on EAS®-clutches. The device is suitable for clutches with a minimum stroke of 1,1 mm with radial actuation and 0,9 mm with axial actuation.

Function

By actuating the metal tappet, contacts 11 – 12 are opened.

Electrical Connection (Terminals)

11 – 12 NC contact

Technical Data

Contact	1 x NC contact, forced disconnection contacts
Contact (Special Design)	additional 1 x NO contact, terminals 23 – 24, galvanically separated (Zb)
Contact-opening	see Switching Travel Diagram
Contact-closing	see Switching Travel Diagram
Contact-load	NC contact 250 VAC / 2,5 A 24 VDC / 1 A min. 12 VDC / 10 mA
Contact distance 250 VAC	>1,25 mm axial, forced opening
Contact distance 24 VDC	<1,25 mm, min. 0,5 mm
Contact material	Ag90Ni10
Max. input current	acc. DIN EN 60947-5-1 AC15 / DC13
Metal tappet travel	max. 4 mm axial or radial
Switching frequency	max. 100/min.
Mechanical lifetime	1 x 10 ⁶ switching cycles, unloaded
Conductor cross-section	1,5 mm ² / AWG 16
Ambient temperature	-30 °C up to +80 °C
Protection	IP65
Protection insulation	acc. Protection Class II
Housing	thermoplastic, self extinguishing acc. UL94-V0
Weight	120 g / 4,2 oz

Installation

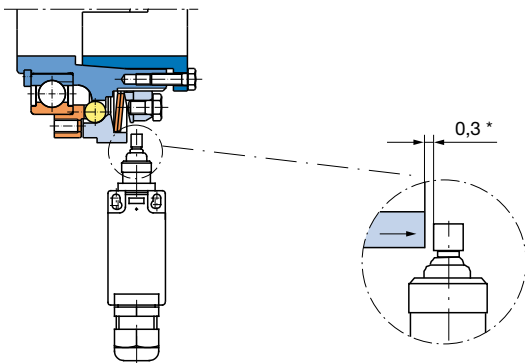

* Switch distance on engaged clutch



Dimensions (mm)

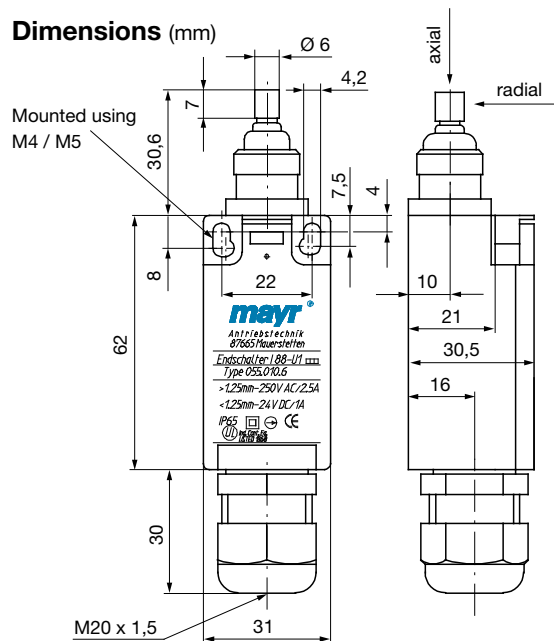

Fixed positioning for safety application with fixing screws 2 x M5 (DIN 912).

Switching Travel Diagram

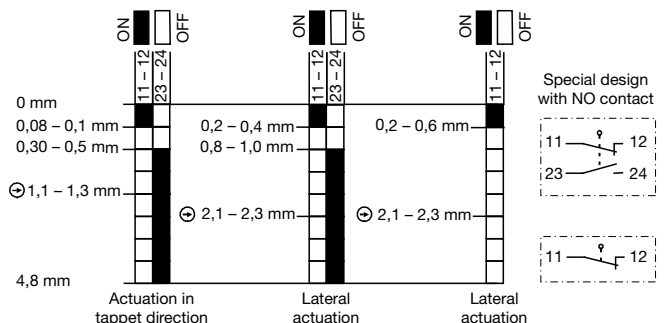

Do not install switch so that it drags and observe max. actuation travel (travel of metal tappet).

Order Number

0 5 5 . 0 1 0 . 6

Installation Examples

EAS®-Compact® short hub

The drive elements of the EAS®-Compact® short hub are centred on the deep groove ball bearing and are screwed together with the pressure flange. If the resulting radial force from the drive element is anywhere near the centre of the ball bearing, an additional bearing for the drive element is unnecessary.



The screw quality and the tightening torque for the fixing screws of the drive element are to be selected so that the set limit torque can be safely transmitted using frictional locking.

Fig. 1

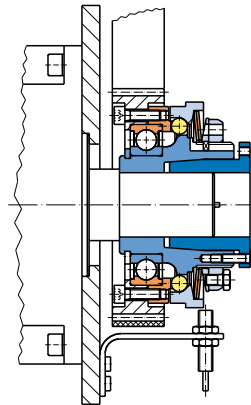

EAS®-Compact® long protruding hub

The EAS®-Compact® long protruding hub is recommended for very wide drive elements or for elements with very small diameters. On a small diameter, the drive element is screwed together via a customer-side intermediate flange with the clutch pressure flange. Ball bearings, needle bearings or plain bearings are suitable as bearings for the drive element, depending on the installation situation and the installation space.

Fig. 2

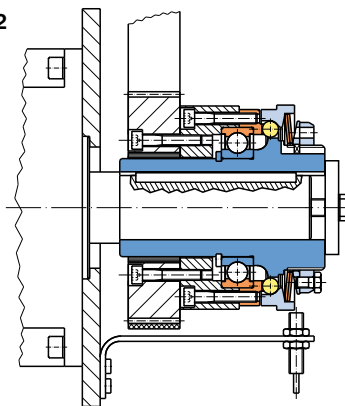

EAS®-Compact® with flexible shaft coupling

The EAS®-Compact® with a backlash-free, torsionally flexible and vibration-damping shaft coupling for the connection of two shafts. The coupling compensates for axial, radial and angular misalignments. In comparison to the EAS®-Compact® with steel bellows coupling, this product is torsionally flexible to a small extent in the circumferential direction.

In the installation example on the right, the EAS®-Compact® lastic is mounted backlash-free between the rotor and a ball screw spindle. The torque is transmitted backlash-free up to the point of disengagement and drops immediately on overload. The contactless limit switch (sensor) emits a signal to switch off the drive.

Fig. 3

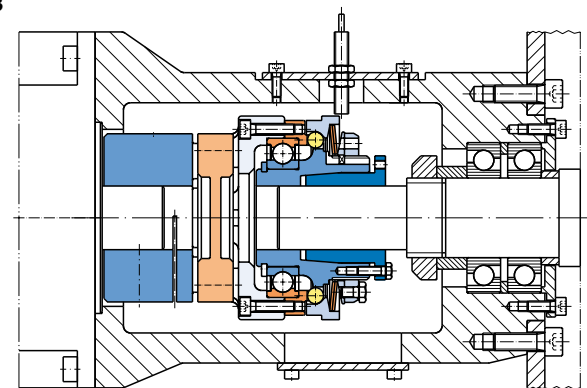

EAS®-Compact® with steel bellows coupling

The EAS®-Compact® with a torsionally rigid flexible steel bellows coupling for the connection of two shafts. The coupling compensates for axial, radial and angular misalignments. It is torsionally rigid in the circumferential direction.

In comparison to the EAS®-Compact® with ROBA®-D coupling, the EAS®-Compact® with steel bellows coupling has a lower mass moment of inertia.

In the installation example on the right, the EAS®-Compact® with steel bellows coupling is mounted between the rotor and a ball screw spindle. The torque is transmitted backlash-free up to the point of disengagement and drops immediately on overload. The contactless limit switch (sensor) emits a signal to switch off the drive.

Fig. 4

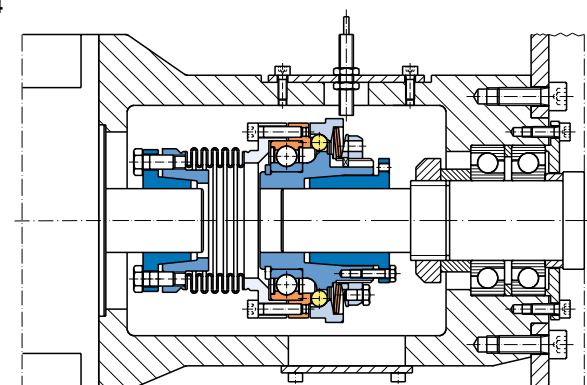

Safety Clutches/Overload Clutches

- ❑ **EAS[®]-Compact[®]/EAS[®]-NC**
Positive locking and completely backlash-free torque limiting clutches
- ❑ **EAS[®]-smartic[®]**
Cost-effective torque limiting clutches, quick installation
- ❑ **EAS[®]-element clutch/EAS[®]-elements**
Load-disconnecting protection against high torques
- ❑ **EAS[®]-axial**
Exact limitation of tensile and compressive forces
- ❑ **EAS[®]-Sp/EAS[®]-Sm/EAS[®]-Zr**
Load-disconnecting torque limiting clutches with switching function
- ❑ **ROBA[®]-slip hub**
Load-holding, frictionally locked torque limiting clutches
- ❑ **ROBA[®]-contitorque**
Magnetic continuous slip clutches



Shaft Couplings

- ❑ **smartflex[®]**
Perfect precision couplings for servo and stepping motors
- ❑ **ROBA[®]-ES**
Backlash-free and damping for vibration-sensitive drives
- ❑ **ROBA[®]-DS/ROBA[®]-D**
Backlash-free, torsionally rigid all-steel couplings
- ❑ **EAS[®]-control-DS**
Cost-effective torque-measuring couplings

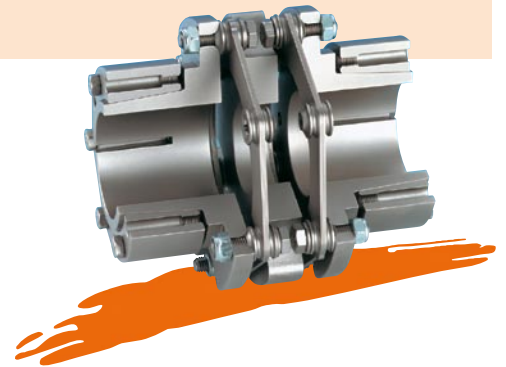

Electromagnetic Brakes/Clutches

- ❑ **ROBA-stop[®] standard**
Multifunctional all-round safety brakes
- ❑ **ROBA-stop[®]-M motor brakes**
Robust, cost-effective motor brakes
- ❑ **ROBA-stop[®]-S**
Water-proof, robust monoblock brakes
- ❑ **ROBA-stop[®]-Z/ROBA-stop[®]-silenzio[®]**
Doubly safe elevator brakes
- ❑ **ROBA[®]-diskstop[®]**
Compact, very quiet disk brakes
- ❑ **ROBA[®]-topstop[®]**
Brake systems for gravity loaded axes
- ❑ **ROBA[®]-linearstop**
Backlash-free brake systems for linear motor axes
- ❑ **ROBATIC[®]/ROBA[®]-quick/ROBA[®]-takt**
Electromagnetic clutches and brakes, clutch brake units



DC Drives

- ❑ **tendo[®]-PM**
Permanent magnet-excited DC motors
- ❑ **tendo[®]-SC**
1 quadrant and 4 quadrant transistor controllers

