

Manual P5/EP5

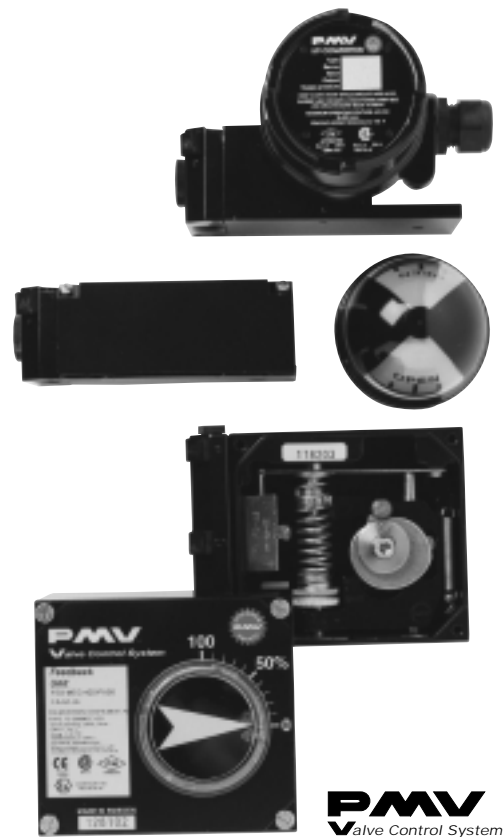

PMV Valve Control System



PMV
Valve Control System



GB

Manufacturers declaration

in compliance with EC directive 89/392/EEC, annex II B and 89/336/EEC.
We hereby confirm that the appliances described in this sheet has been manufactured in compliance with the applicable standards and is intended for installation in a machine/application, and that commissioning is strictly prohibited until evidence has been provided that the machine/application in question is also in compliance with EC directive 89/392/EEC and 89/336/EEC.

This manufacturers declaration is applicable to the following PMV-Positioner series:
P5, EP5, F5.

D

Hersteller-Erklärung

im Sinne der EG-Richtlinie 89/392/EWG, Anhang II B und 89/336/EWG.
Hiermit erklären wir, daß die in diesem Blatt beschriebenen Geräte entsprechend den gültigen Normen gebaut und zum Einbau in eine Maschine oder Applikation bestimmt sind, sowie daß deren Inbetriebnahme so lange untersagt ist, bis festgestellt wurde, daß diese Maschine/Applikation ebenfalls der EG-Richtlinie 89/392/EWG und 89/336/EWG entspricht.
Diese Herstellererklärung hat für folgende PMV-Stellungsregler-Serien Gültigkeit:
P5, EP5, F5.

F

Déclaration de fabricant

au sens de la directive de la CE 89/392/CEE, annexe II B et CE/89/336/CEE.
Nous déclarons par la présente que les appareils décrits sur cette page sont construits en conformité avec les normes en vigueur et qu'ils sont destinés à être montés dans une machine ou une application, nous déclarons également que leur mise en service est interdite tant qu'il n'a pas été constaté que cette machine/application satisfait également à la directive CE 89/392 CEE et CE/89/336/CEE.
Cette déclaration de fournisseur est valable pour les types d'appareils PMV suivants:
P5, EP5, F5.



Mr. Roland Wedebrand
President, Palmstiernas Instrument AB



Contents

	Page
1. Introduction	4
1.a Storage Instructions, Storage Seal	5-6
2. Function	7
3. Air requirements	8
4. Installation	8
5. Connections	9
6. Front cover and the indicator cover	10
7. Span and zero adjustment	11
8. Indicator adjustment	12
9. Cam adjustment	12
10. Dampers	12
11. I/P Unit, EP5	13
12. How to mount the I/P Unit	14
13. Maintenance	15-19
Pilot valve	15
Diaphragm	16
Feedback spring	17
Balance arm	17
Lower arm	18
O-rings	18
Filter plug	19
14. Feedback Unit	20
15. Trouble shooting	21
16. Technical Data	21
17. Exploded Drawing	22
18. Spare part list	23
Approvals	24-27



1. Introduction

Always check www.pmv.nu for latest edition of manual.

The P5 Valve Control System is a valve positioning system from PMV with a modular design concept.

The base unit of the system is the pneumatic positioner, used in either single or double acting applications. P5 comes standard with built in dampers, a 5 mm high gain spool valve assembly, gauge ports and an O-ring sealed housing. The housing utilizes a unique O-ring seal that can be adjusted to a sealed or drained position.

The modular design concept allows for easy addition of accessories such as I/P converter and/or a feedback package, both which are isolated from the basic pneumatic unit. These accessories can be factory or field mounted.

Ease of calibration and maintenance are built into to the design with easily accessible span and zero adjustment, and very simple parts replacement.

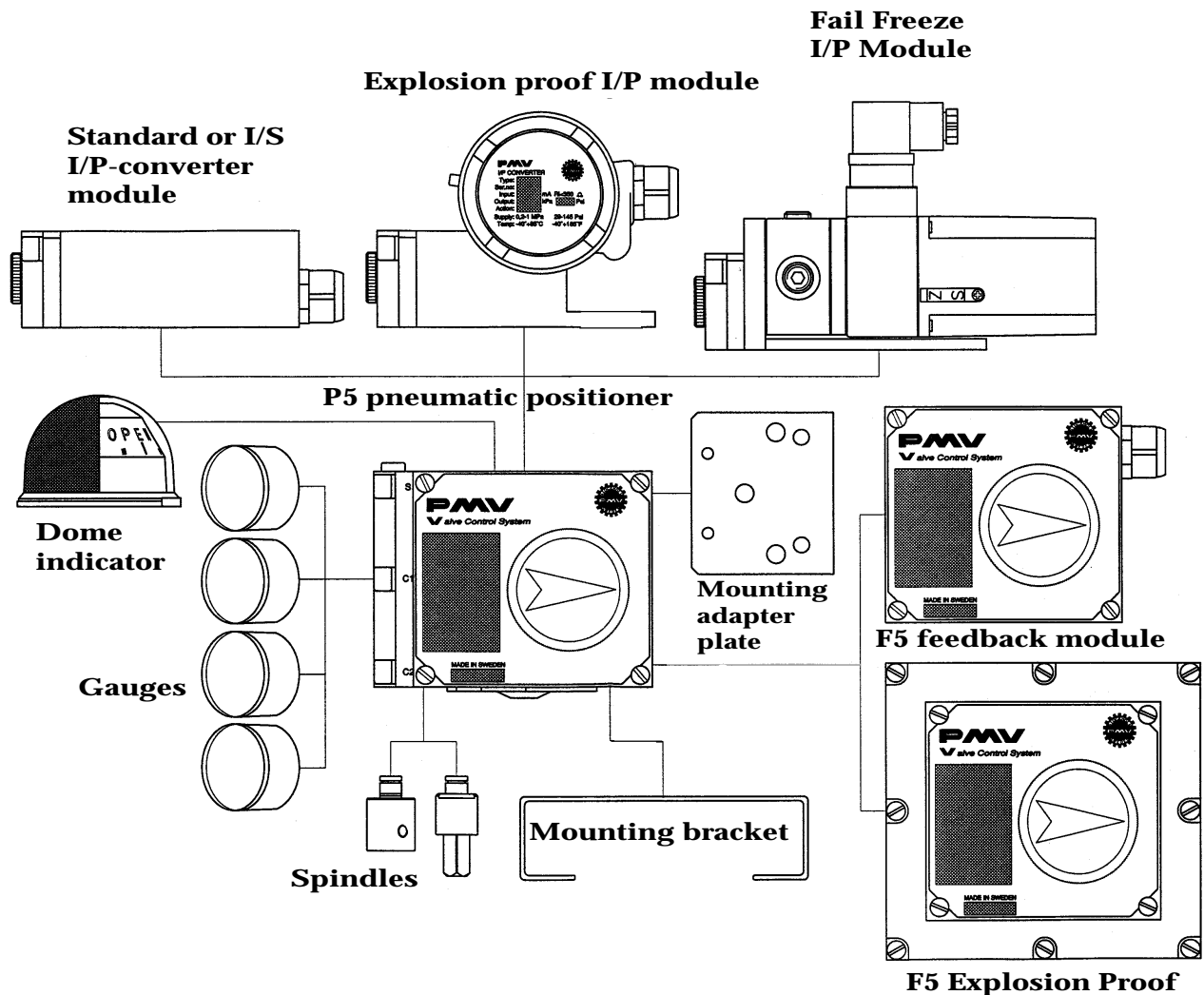

1.a Storage instructions

PMV Positioner and feedback module storage and handling procedures

PMV Positioners and feedback modules are precision instruments which should be stored and handled accordingly to avoid problems or damage.

Electropneumatic positioners/feedback modules contain electronic components which can be damaged by exposure to excessive water. Appropriate precautions should be taken to protect units while in storage.

Warehouse storage

Stored in original PMV shipping containers, units should be stored in an environmentally controlled area, i.e. clean, cool (15-26°C, 60-80°F) and dry, out of direct sunlight or weather exposure.

Field storage

Note: Once the air supply to the positioner is connected and turned on, internal air bleed will prevent the ingress of moisture and protect the unit from corrosion. It is recommended that the air supply be left on at all times.

- If units are installed immediately, turn, and leave on, the air supply.
- If positioners must be stored outdoors, tighten all covers which may have loosened in shipment, make sure all open enclosure entry points are sealed.

Feedback modules should have cover tightened and conduits entries sealed. Positioners/Feedback modules should be wrapped and sealed air and watertight with desiccant inside the plastic, units should be securely covered with an opaque cover and not exposed to direct sunlight, rain or snow.

Pneumatic positioners

Units should have all ports sealed and be protected from direct exposure to weather. For long term storage (>1 month) or overseas shipment units should be protected with plastic and desiccant.

Potential damage mechanism

When units are stored in hot, humid climates, the daily heating/cooling cycle will cause air to expand/contract and be drawn in and out of the positioner/feedback housing. Dependent on the local temperature variations, humidity and dew points and time in storage condensation could occur and accumulate inside on the I/P Converter causing erratic operation or failure due to water and corrosion. The potential for condensation damage is especially high in southern climates and aggravated if units are exposed to direct sunlight.

For further assistance, please contact you nearest PMV office.



Storage Seal

P5/EP5 is supplied with all enclosure entry points sealed. The seal is only a storage seal, not to be used as seal when P5/EP5 is in operation. If Storage Seal is removed or damaged, make sure all open enclosure entry points are properly resealed before further shipping or storage. Use circular stickers marked I, S and OUT, supplied on Storage Seal or vapour proof tape.

P5

Remove Storage Seal from connection block, mount positioner on actuator/valve, make connections according to section 5, (Page 9). Calibrate span and Zero according to section 7, (Page 11).

Clean any oil/debris off the connecting block, then reseal open enclosure entry ports, use circular stickers marked I, S and OUT, supplied on Storage Seal or vapour proof tape.

EP5

Follow P5 instructions as above. Remove Storage Seal for conduit entry I_E, connect input signal cable and install proper cable gland to secure the units sealing.

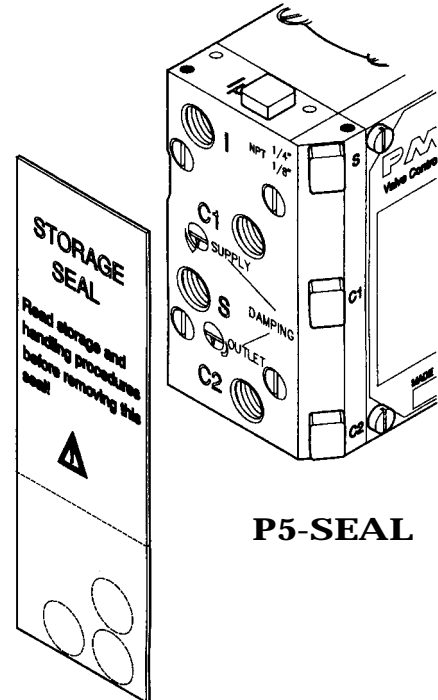

P5-SEAL

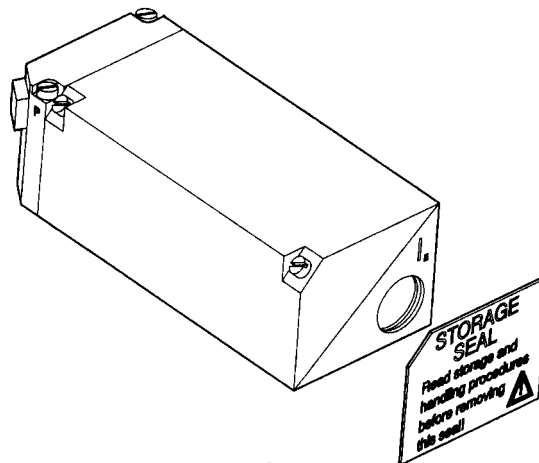

IP5-SEAL



2. Function

The P5 operates on a force balance principal. Force is originated by the signal pressure transmitted through a diaphragm on to the balance arm. The opposing force is achieved through the feedback spring and is proportional to the position of the lower arm. The lower arm position is determined by the position of the cam which is secured to the spindle and connected to the actuator shaft thus providing the feedback from the actuator/valve. When these two forces are equal, the balance arm and the spool in the pilot valve are in a neutral position -the complete unit is in a balanced position. Air is supplied to the pilot valve through port S, and controls the air flow through ports C1 and C2

Assume an equilibrium position.

An increased control pressure will deflect the diaphragm 1 down, compressing the feedback spring 3. The balance arm 2 moves the spool 7 in the pilot valve 8 furnishing supply air to the actuator, while at the same time air is exhausted from actuator and is vented to atmosphere through the pilot valve and the OUT port .

With the increased supply air, the actuator rotates (or moves linearly) moving the positioner spindle 6. The spindle and cam 5 rotate, forcing the lower arm 4 upwards compressing the feedback spring 3. This motion will continue until the two forces are equal and the unit is in an equilibrium position.

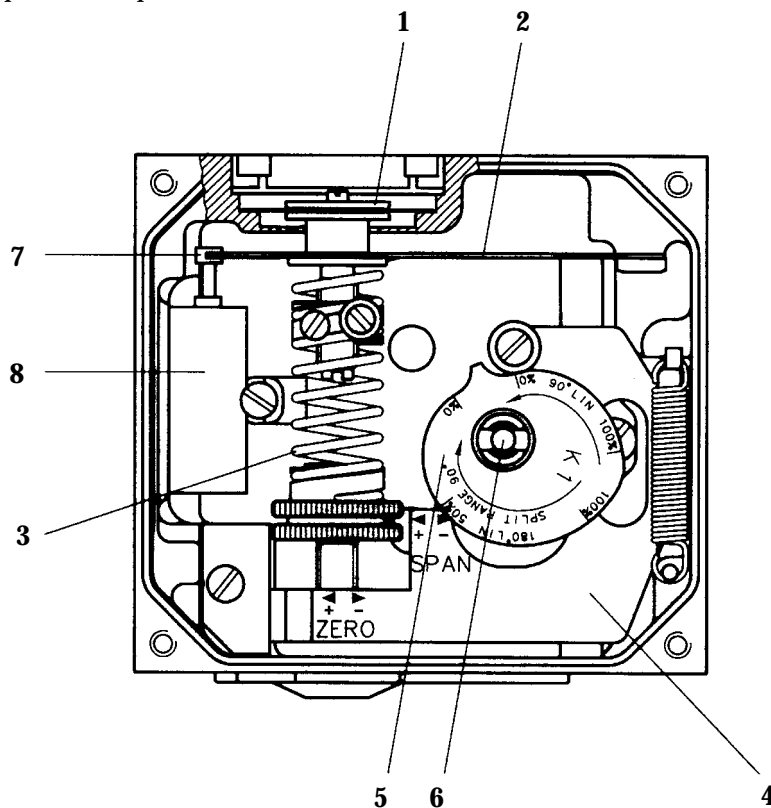

3. Air requirements

Maximum supply pressure is 1 MPa (150 psi).

Supply air shall be clean, dry and free from oil, water, moisture, foreign parts and debris.

The air shall be freeze-dried or similar to a dew point of at least 10°C (18°F) below lowest expected ambient temperature.

A <40µ filter/regulator is recommended to be installed as close to P5/EP5 as possible to ensure proper supply air quality.

Before making pneumatic connections to the positioner, it is recommended that the supply air lines are opened up and allowed to vent for 2-3 minutes to clear any debris from the line. It is further recommended that a large paper bag is used to collect any oil or humidity that may be present in the line during this purging, direct the air flow into the bag. Should excessive amounts of oil and/or humidity be present at this stage, a review of the pneumatic system should be carried out and the problem corrected.

Poor air quality is one of the major causes of premature failure of pneumatic equipment.

4. Installation

P5 mounts on to the actuator using either the ISO F05 holes 4 and a PMV ISO mounting kit or by using the optional mounting adaptor and screws 5 to mount P5 on to existing PMV mounting kits.

Proper alignment of the positioner spindle to the actuator shaft is very important since improper alignment can cause excessive wear and friction to the positioner.

The spindle/positioner shaft assembly allows for quick and simple spindle changes. To ensure the proper connection, the spindle 3 has a spring clip 2 that must be properly installed. A solid "click" should be felt when assembling the two pieces insuring that the two flats 1 are engaged into the positioner shaft groove.

The spindle can be removed, by inserting two screwdrivers under the two tapered surfaces of the spindle and bending carefully. When the spring clip releases the spindle will eject.

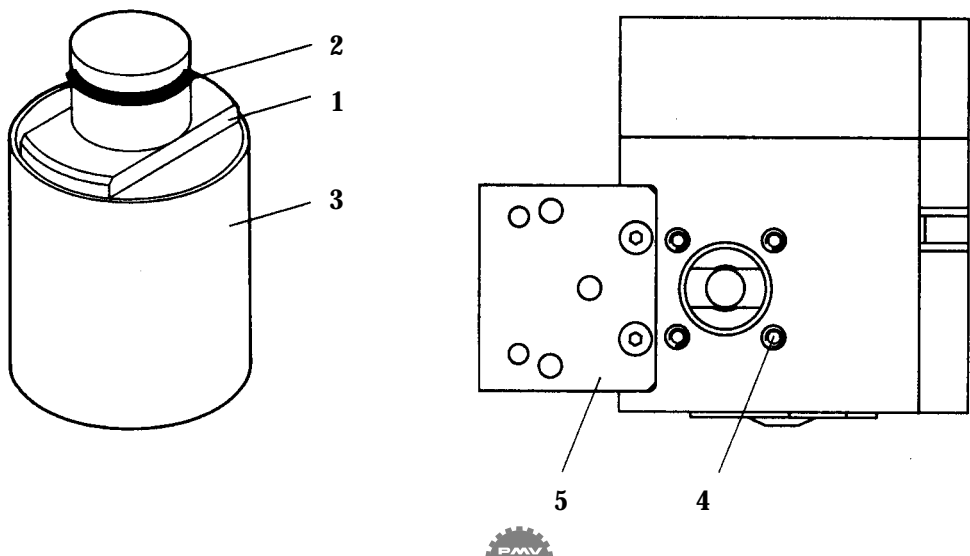

5. Connections

Air connections are tapped for 1/4" G or NPT male connectors and are clearly marked. Gauge ports are for 1/8" G or NPT.

We recommend use of tape, Loctite® 577 or similar user preferred for sealing.

Electrical connection on I/P unit accepts 1/2" NPT or PG 13,5 (M20) cable gland.

Port I	Input instrument pneumatic signal 20-100kPa (3-15 psi)
Port S	Supply air, maximum 1 MPa (150 psi) Minimum 0,15 MPa (21 psi) for EP5
Port C1, C2	Actuator connections (0,2-1 MPa). C2 opening port.
OUT	Exhaust air port. Do not block! Exhaust filter optional.
Port Ip	Gauge port for pneumatic input signal.
Port I_E	Input electric signal (4-20 mA) (On the I/P unit.)
Port P	Gauge port for I/P unit output pressure (On the I/P unit)

Ports **Ip, P, S, C1 and C2** are sealed with plugs. To install gauges, unscrew plugs and replace with gauges.

We recommend use of tape, Loctite® 577 or similar user preferred for sealing.

Port **OUT** is for venting the unit. All air from the positioner, actuator and I/P unit is vented to atmosphere through this port. **Do not block this port.** A high flow silencer or an exhaust pipe can be connected to this port to prevent foreign objects from entering and blocking the units exhaust. Connector in exhaust port must not have less than 9 mm (3/8") orifice.

When using gases other than air for supply – Please contact PMV.

On EP5 (P5 with I/P unit installed) I/P unit is supplied with air from port S. Port I is automatically sealed off and protected. No connection shall be made to this port. See pages 13 and 14 for more information.

For single acting operation plug port **C1** for increasing signal to open valve. Plug **C2** for decreasing (reverse) signal to open valve.

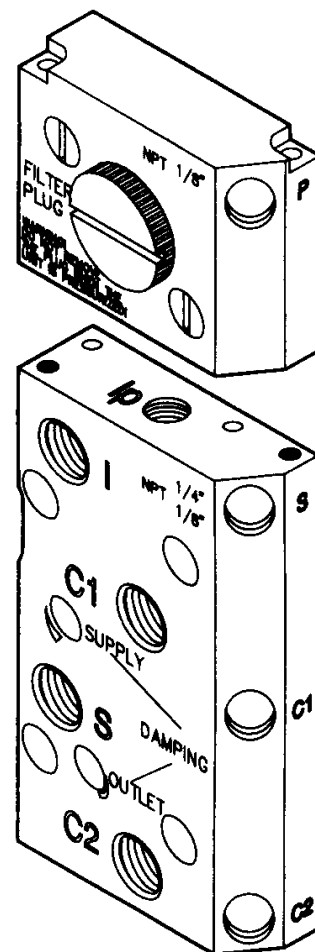

6. Front cover and indicator cover

The front cover of P5 is secured to the pneumatic unit with four captured screws and sealed with an O-ring **1**. The O-ring can be looped over notches **2** in the front cover to allow for drainage.

There are eight locations on the front cover where the O-ring can be looped. This O-ring system is common to the Pneumatic unit, I/P unit and Feedback unit in the PMV Valve Control System P5. This unique sealing system allows for complete sealing or draining of the units by changing the position of the O-ring.

The indicator cover **3** is O-ring sealed and secured by a bayonet coupling. The indicator cover is also used to secure the identification cover **4**.

To remove the indicator cover turn it slightly counterclockwise until it loosens. Identification cover and O-ring **5** are now removable.

When installing indicator cover and identification cover make sure that the O-ring is properly engaged.

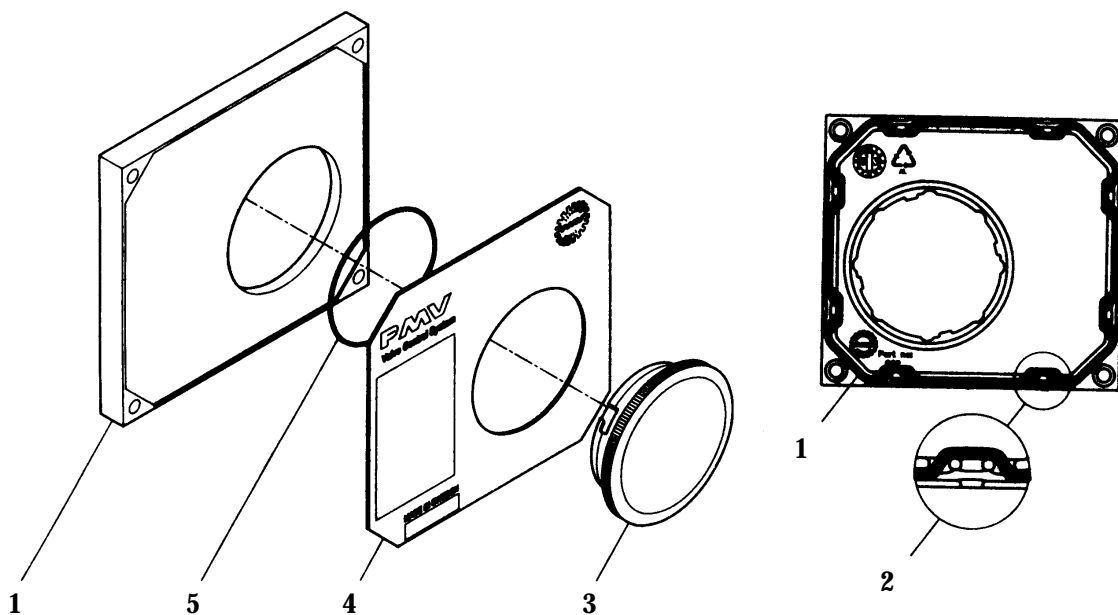

7. Calibration

P5/EP5 is when shipped from PMV pre-calibrated for $90 \pm 0,5$ deg rotation, (can also be 30, 45 or 60 deg, see installed cam).

For most applications the valve closed position is more critical than valve open position, most attention should be paid at valve closed position. Always start calibration procedure by applying 0 % input signal, then adjusting zero. P5/EP5 is calibrated by turning thumb wheels 1 & 4.

Arrows on arm 5 indicate turning direction of thumb wheels.

< "+" = Increase zero/span

> "-" = Decrease zero/span

Calibration procedure

Check cam seating, section 9 before starting calibration procedure.

1. Apply 0 % input signal (0% = 20 kPa/3 psi or 4 mA)
2. Wait for steady state.
3. Adjust zero by turning the silver (lower) thumb wheel 4 with finger or with screw driver 7 from the outside.
4. Apply 100% input signal (100% = 100 kPa/ 15 psi or 20 mA)
5. Wait for steady state then memorize result.
6. Apply 0% input signal.
7. Adjust span if necessary. This is done by first loosening screw 2, then turning the yellow (upper) thumb wheel 1 "+" or "-" and finally tighten screw 2. Spring top must not be in contact with spring guide 3.
8. Check zero and adjust if needed.
9. Repeat steps 2 to 8 until desired calibration is achieved.

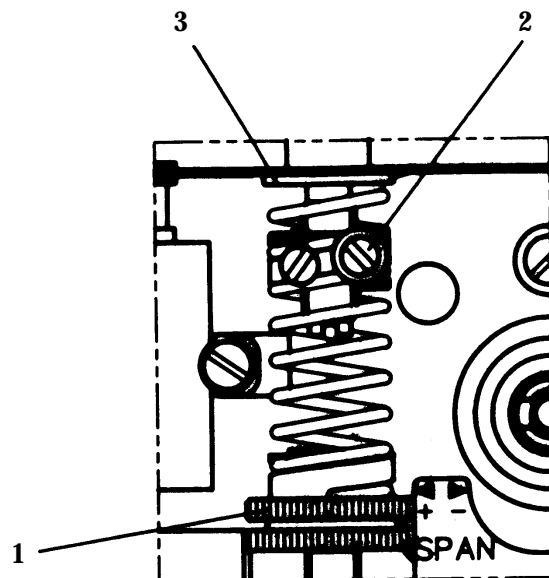
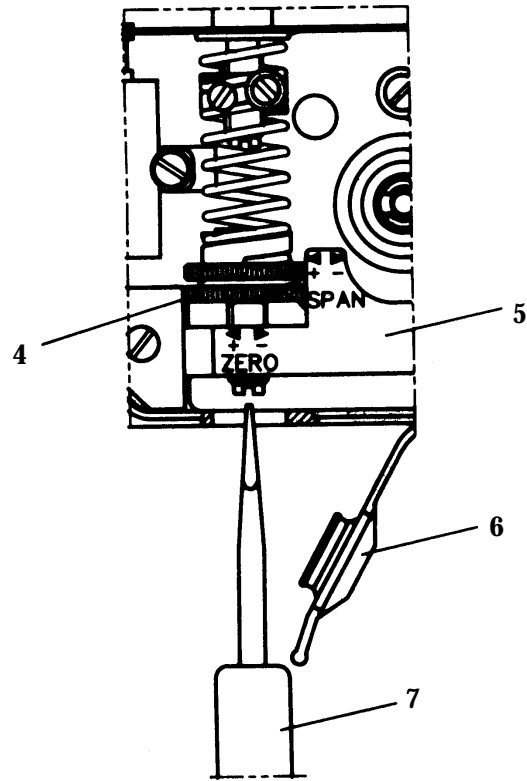

8. Indicator adjustment

To adjust the indicator, take off front cover and pull the indicator upwards until it comes off the Allen screw.

Before installing the indicator make sure that the Allen screw is tightened. Press the indicator on the screw and adjust it by rotating clockwise to desired position.

9. Cam adjustment

With the cover and indicator removed, loosen the screw 1 and turn the cam locking nut 2 counterclockwise until the cam loosens. Adjust the cam 3 as desired making sure that the ball bearing 4 always is riding on an active lobe on the cam. To secure the cam, make sure that screw 1 is backed out from the locking nut 2 then finger tighten the locking nut and tighten screw 1. Install and adjust the indicator and reinstall cover.

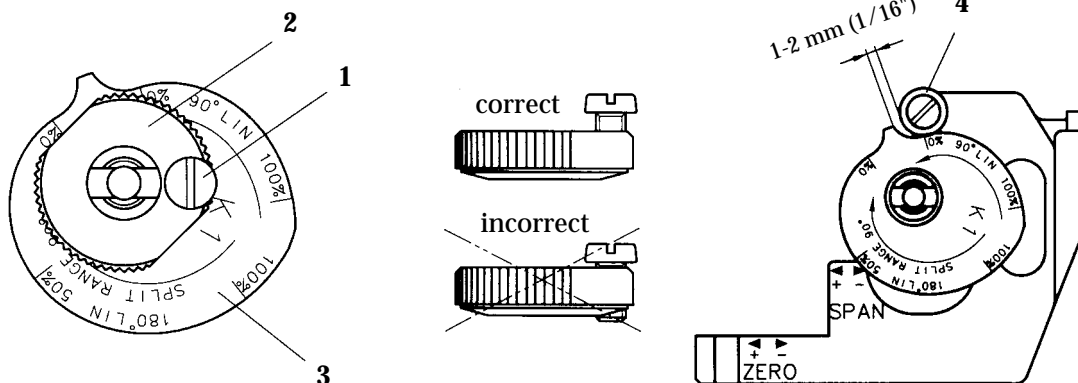

10. Dampers

The standard built in dampers 5 located on the connecting block provide a simple means of adjusting the actuator travel speed.

For maximum actuator travel speed dampers shall be adjusted to minimum damping position. (Fig).

Double acting actuators – adjust only OUTLET damper, set SUPPLY damper in minimum damping position.

Single acting actuators – adjust both dampers for desired operation.

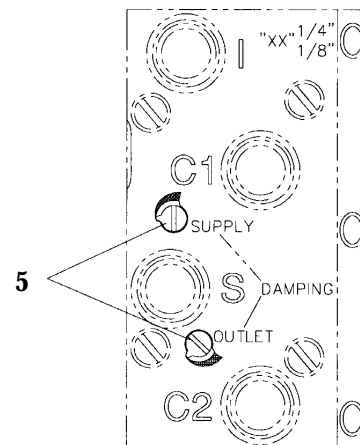

11. I/P Unit, EP5

WARNING! Units installed in hazardous areas must have proper approvals.

The I/P unit is mounted directly on top of the positioner unit. No external air supply is needed since the I/P unit is supplied with air from the positioner unit.

Port I on the positioner unit will be plugged when the I/P unit and the appropriate gauge block gasket installed. The I/P unit accepts a 4-20 mA input signal.

The I/P unit is equipped with a built in 30 micron filter (Fig 4).

Caution: Do not operate the unit without filter and filterplug installed. Do not unscrew filterplug when the positioner is pressurized.

Span and Zero for the I/P converter is factory set and can not be adjusted

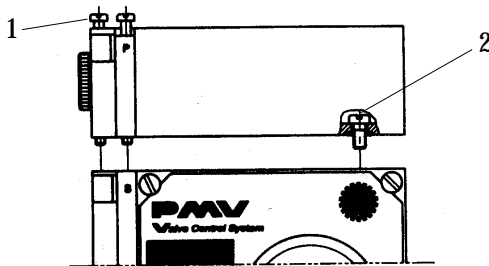

Fig 1

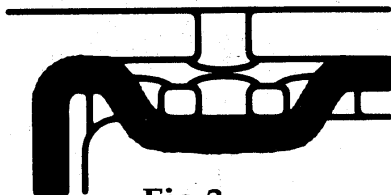

Fig 3

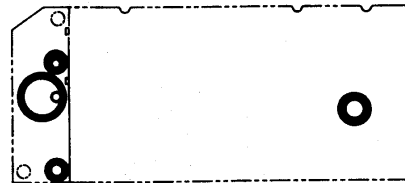

Fig 2

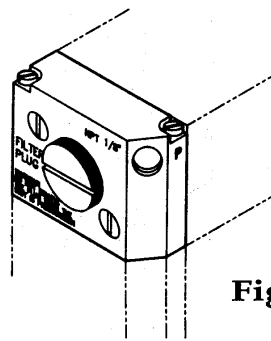

Fig 4

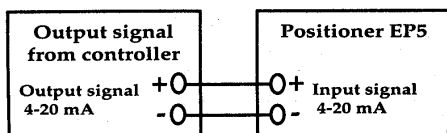

Fig 5

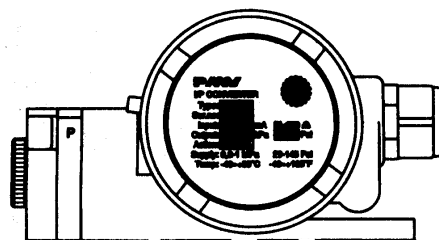

Fig 6



12. How to mount the I/P Unit to the positioner Unit

Switch off supply air and disconnect input signal – port I.

Loosen screws **3** and remove connection block **1**, the gauge or plug from port **I_p**, the fitting from port **I** and existing gasket **4**. Carefully install gasket **6** supplied together with I/P unit. When correct installed port **I** will be blocked by the gasket.

Make sure that relief valve spring **5** is installed properly. Install the connection block **1** to the positioner unit **2**.

Remove cover on I/P unit.

Install the I/P unit to the top of the Positioner unit, making sure that the four O-rings are present and properly seated. Tighten the unit with the three screws. (See fig. 1 and 2 page 13) Screw 1 first, screw 2 last.

WARNING! Units installed in hazardous areas must have proper approvals.

Connect input signal cable to port **I_E** and tighten the cable gland (see fig 5 on page 13). Adjust the O-ring on the I/P Unit housing to desired position - sealed or drained. (See fig 3 on page 13 or section 6 on page 10).

A gauge indicating output signal from the I/P converter can be installed in port **P**. Make sure that the filter plug is tightened before supply air is switched on (Fig 4 on page 13).

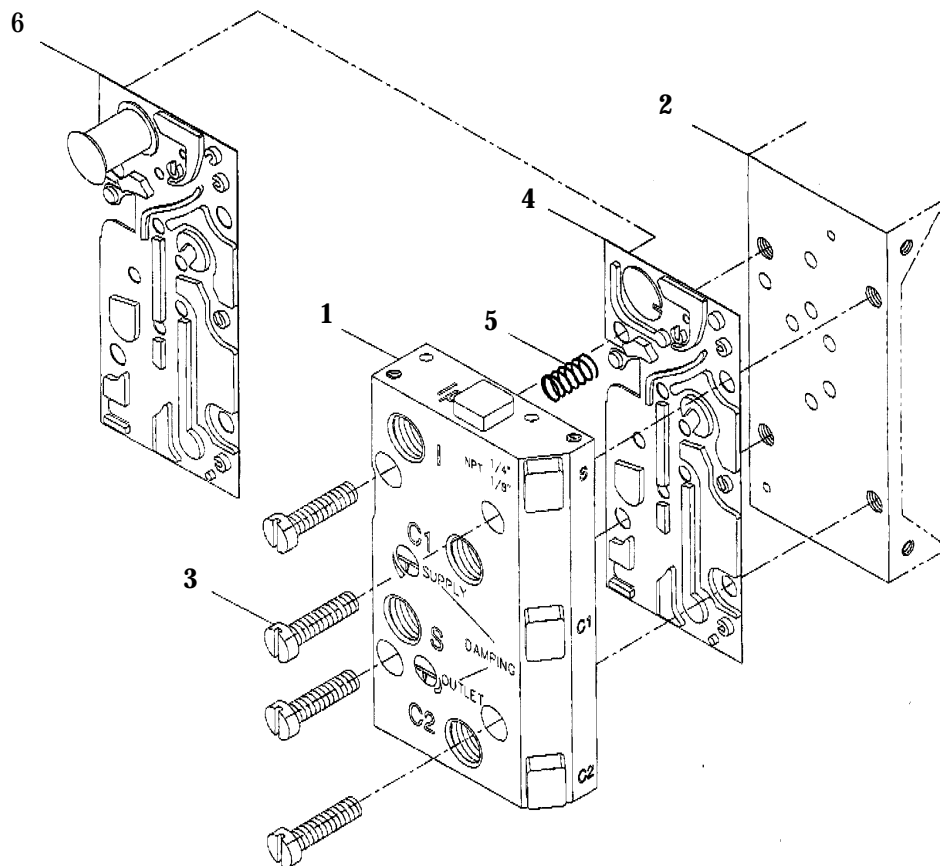

13. Maintenance

Pilot valve

To remove the pilot valve for cleaning or inspection, remove the screw **1** and carefully lift out the complete assembly **2**. Gently remove the spool **3** from the block and clean the parts, using methylate cleaner or similar. Blow the parts dry with compressed air. Install the spool into the pilot valve housing, place it on a flat surface, then lift it carefully in one end. Before reaching 20 deg angle the spool should move by itself.

Should the parts show signs of wear, a new assembly is recommended. Mixing spool valves and valve bodies may result in very high bleed rates and poor performance. Check the O-rings, then secure and install the pilot valve assembly into positioner unit, press it towards the positioner housing wall and secure it with screw **1**. Make sure that the leaf spring **4** on the balance arm **5** is properly fitted in the groove on the spool **6**. Check again to insure smooth operation of the assembly.

To maintain original factory performance specifications, use only spool valve assemblies supplied by PMV

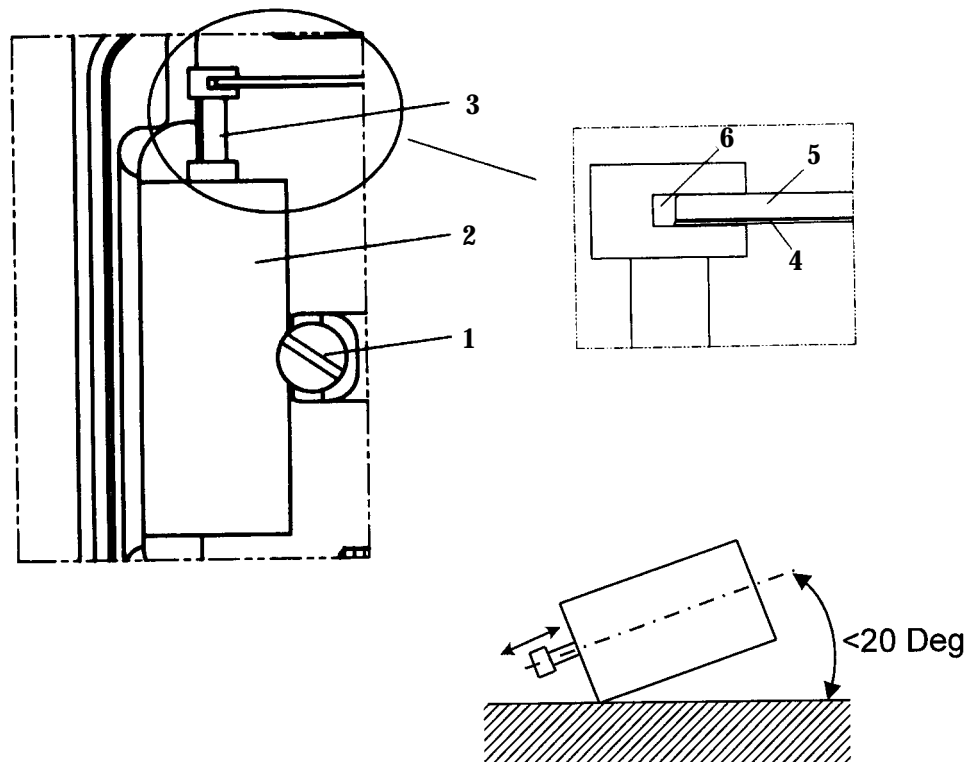

Diaphragm

If P5 is equipped with I/P unit (EP5), the I/P unit must be removed to access the diaphragm.

When installing the diaphragm make sure to place one washer on each side of the diaphragm.

Put some Loctite 577 on the thread, install the screw **3** and tighten. Make sure the diaphragm is centered.

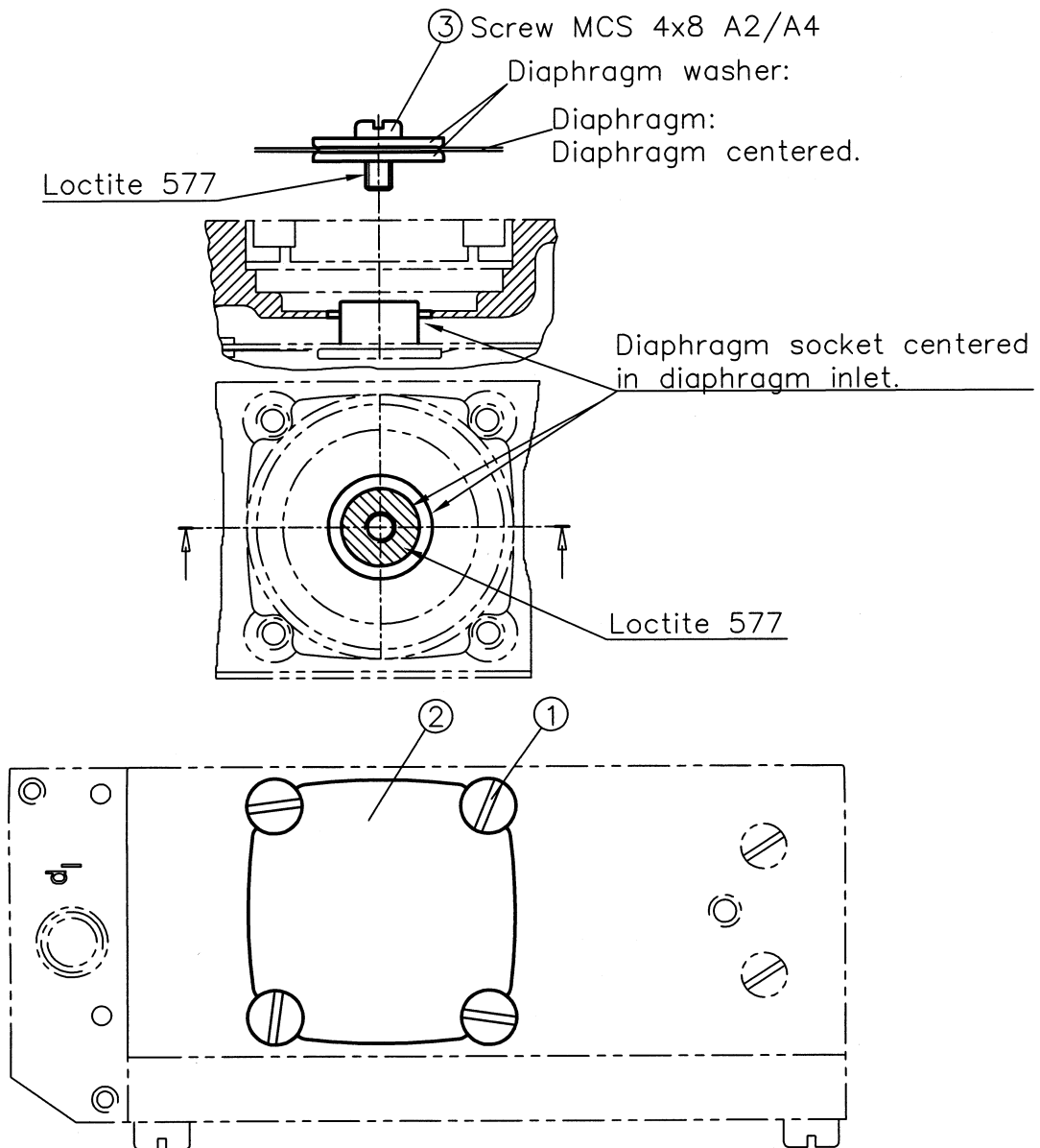

Check the O-ring for the diaphragm cover **2**, install the O-ring into the positioner housing, then install cover **2**. Secure crosswise with screws **1**, first turn loosely. Torque shall be 4,5 Nm (40 in-lbs).



Feedback spring

Once the front cover and indicator are removed, the feedback spring can be easily accessed.

Hold the spring 1 from the top, pull down and out.

When installing, hold the assembly at the top, guide the lower part to position on the zero screw, then press down until it fits easily under the balance arm 2. Make sure that the assembly is aligned properly against the lower arm and the notch is engaged in the tab on the balance arm 2.

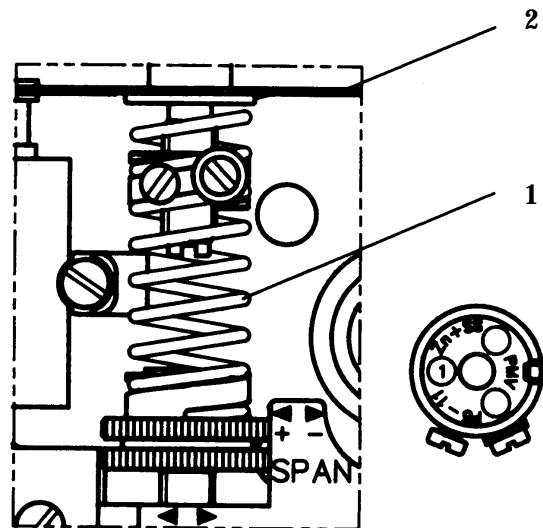

Balance arm

The balance arm can only be removed after I/P unit, diaphragm and feedback spring have been removed. (See sections above and on page 13, 14 and 16).

Loosen the screws 3 and the balance arm can be removed.

When installing the balance arm make sure that the leafspring 4 on the underside of the balance arm 5 is properly engaged into the groove 6 of the spool in the pilot valve.

Tighten the two screws 3 holding the balance arm to the positioner.

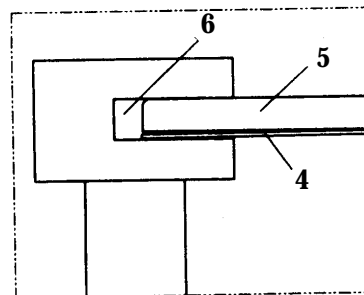
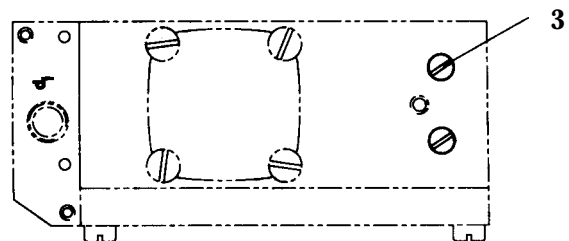

Lower arm

Once the front cover is removed, the lower arm can be easily accessed. Remove the indicator, feedback spring and the cam.

Loosen screw 2 and remove twist stop 1.

Remove screw 3, lower arm 4, rod 5 and spring 6.

Check rod and lower arm for wear, replace if necessary. Clean the rod and install it in the lower arm. The lower arm should move easily and smoothly.

Install the lower arm and rod assembly into the positioner housing, making sure that the spring 6 is attached properly to the lower arm and positioner housing.

Secure the lower arm and rod assembly with the screw 3.

Check again that the lower arm moves smoothly.

Apply a small amount of grease on the small tongue on the lower arm, then install and secure the twist stop.

Install cam, feedback spring, indicator and front cover.

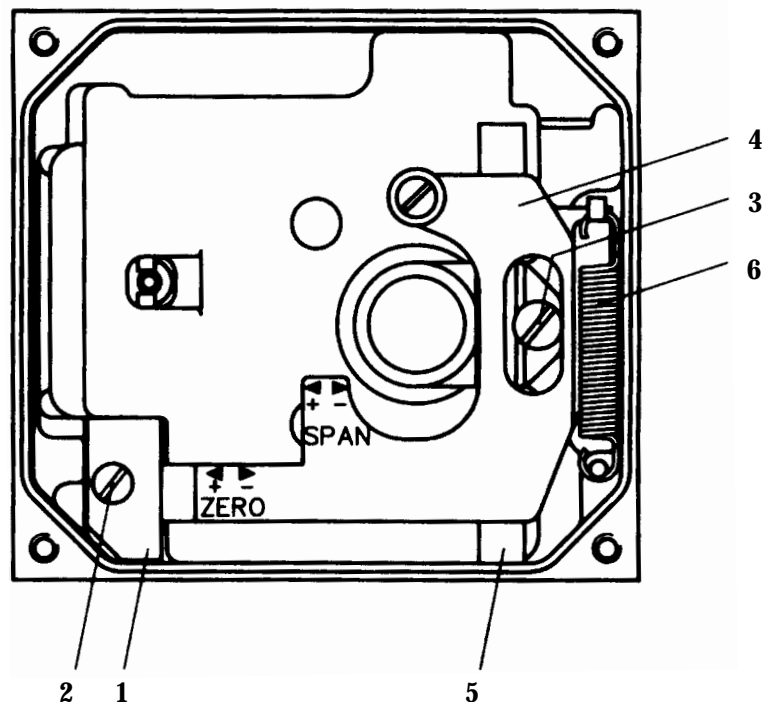

O-rings

With time and use, O-rings can become brittle. This can cause poor operation and even failure of the positioner.

Always check O-rings when performing any work on the positioner and replace bad O-rings.

A thin layer of silicon grease applied on the NBR (Black) O-rings prolongs their life. On Q (red) O-rings, use a non silicon based grease.



Filter plug

Caution! Do not operate the unit without filter and filter plug installed. Do not attempt to unscrew filter plug while positioner is pressurized.

EP5 is equipped with a built in secondary filter located on the side of the I/P unit.

For replacement or inspection, make sure that positioner unit is not pressurized, then unscrew filter plug **1**. Remove filter **3** and install a new into the filter plug . Check condition of O-ring **2** and filter compartment. If moisture is found, check upstream filters/oil-water separators. Moisture can cause I/P failure.

Reinstall filter plug.

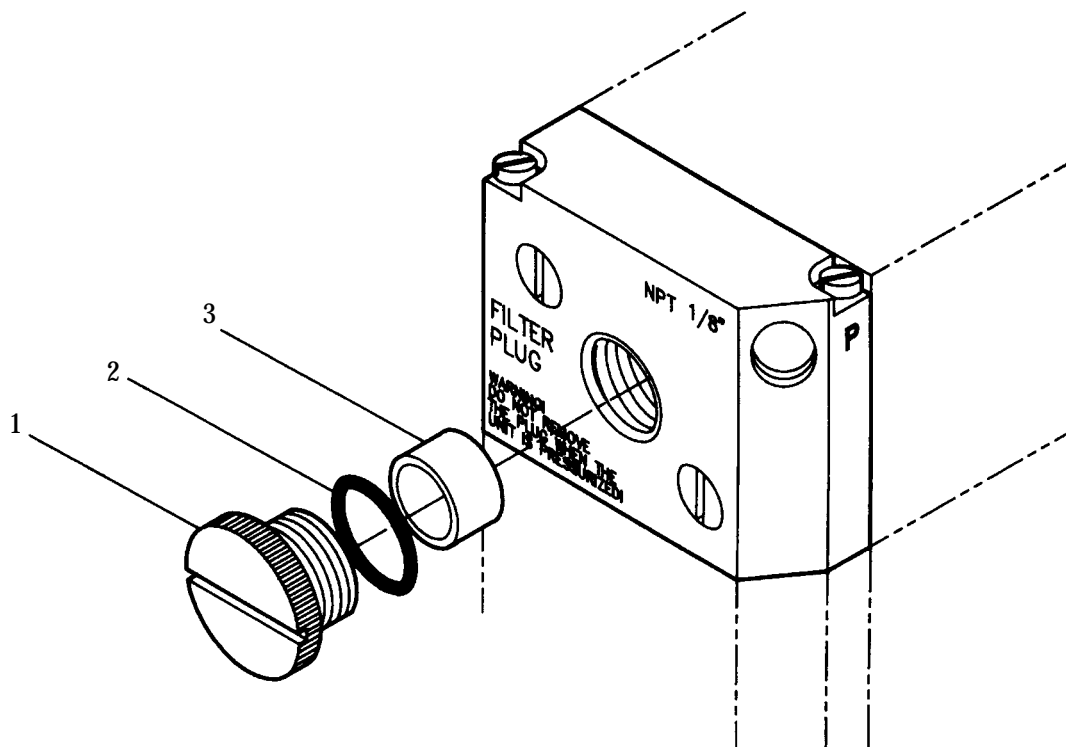

14. Feedback Unit

See feedback module instructions for connections and calibration.

The P5 or EP5, Valve Control System, can easily be equipped with a Feedback unit, model F5. This unit will mount directly on top of the Pneumatic positioner replacing the positioner front cover. The O-ring located on the bottom of the Feedback unit, F5, will provide the same sealing or draining capabilities as the front cover. The indicator and front cover from the positioner unit can then be installed on to the Feedback unit.

WARNING! Units installed in hazardous locations must have proper approvals.

Installing the feedback unit.

- Remove the front cover, indicator, and Allen head screw from the top of the positioner spindle.
- Install the drive coupling 4 and adjust the O-ring seal on the bottom in either sealed or draining position. (See section 6, page 10).
- Install the Feedback unit 9 on top of the Positioner unit, making sure the coupling is properly engaged before tightening the four screws 5.
- Make electrical connections and tighten cable glands. (See F5 manual for details).
- Adjust cams and/or potentiometer to desired position.
- Install the indicator and front cover.

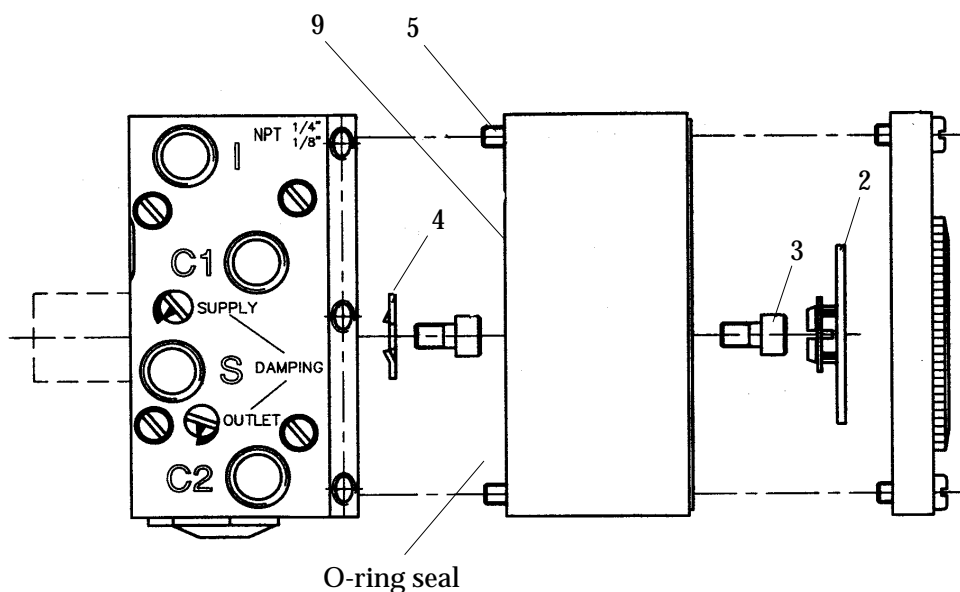

15. Trouble shooting

Note: All PMV-positioners are serialized. Please note down, and provide the serial number when contacting the factory for trouble shooting or service.

Signal change has no effect on the actuator position.

- Check indicator and screw.
- Check air supply to positioner and tubing to the actuator.
- Check input signal to positioner.
- Check diaphragm for damage or leakage.
- Check pilot valve function.
- Check cam for correct setting.
- Check I/P output

Signal change results in actuator running to end positions.

- Check coupling between positioner and actuator.
- Check cam position and locking screw.
- Check input signal.

Inaccurate positioning.

- Dirty or worn pilot valve.
- Defective or leaking diaphragm.
- Input signal fluctuates.
- Incorrect sizing of actuator.
- Valve/actuator "stiction".
- High valve/actuator breakaway torque.
- Loose cam.

16. Technical Data

	P5	EP5
Input Signal	20-100 kPa/3-15 Psi (6-30 optional)	4-20 mA
Linearity	≤ 0,5%*	≤ 0,5%*
Hysteresis	≤ 0,75%*	≤ 0,5%*
Repeatability	≤ 0,5%*	≤ 0,5%*
Gain	(pressure 600 kPa/87 Psi) 1 000 (kPa/kPa) Min 66%/ % ISA S75.13	
Air consumption at Supply pressure:		
0,2 MPa/29 Psi	5,4 nl/min 0.19 SCFM	6,1 nl/min 0.22 SCFM
0,4 MPa/58 Psi	12,3 nl/min 0.43 SCFM	13,6 nl/min 0.48 SCFM
0,6 MPa/87 Psi	20 nl/min 0.71 SCFM	22 nl/min 0.78 SCFM
0,8 MPa/116 Psi	27,8 nl/min 0.98 SCFM	30,5 nl/min 1.08 SCFM
1 MPa/145 Psi	35,7 nl/min 1.26 SCFM	39 nl/min 1.38 SCFM
Air delivery at Supply Pressure:		
0,2 MPa/29 Psi	200 nl/min 6.9 SCFM	
0,4 MPa/58 Psi	370 nl/min 12.8 SCFM	
0,6 MPa/87 Psi	540 nl/min 18.8 SCFM	
0,8 MPa/116 Psi	710 nl/min 24.7 SCFM	
1 MPa/145 Psi	880 nl/min 30.6 SCFM	
Supply Pressure	Max 1 MPa/150 Psi	0,15-1 MPa/21,8-150 Psi
Temperature range	-20°C to +85°C (-4°F to 185°F)	
Connector threads	1/4" NPT or G	
Gauge threads	1/8" NPT or G	
Weight std.	1,1 kg/2.4 lbs	1,5 kg/3.4 lbs
Weight with gauges	1,3 kg/2.9 lbs	1,8 kg/3.9 lbs
Ingress protection	IP 66/NEMA 4	

* Per cent of full scale.

(The information in this manual is subject to change without notice.)



17. Exploded Drawing

00-13

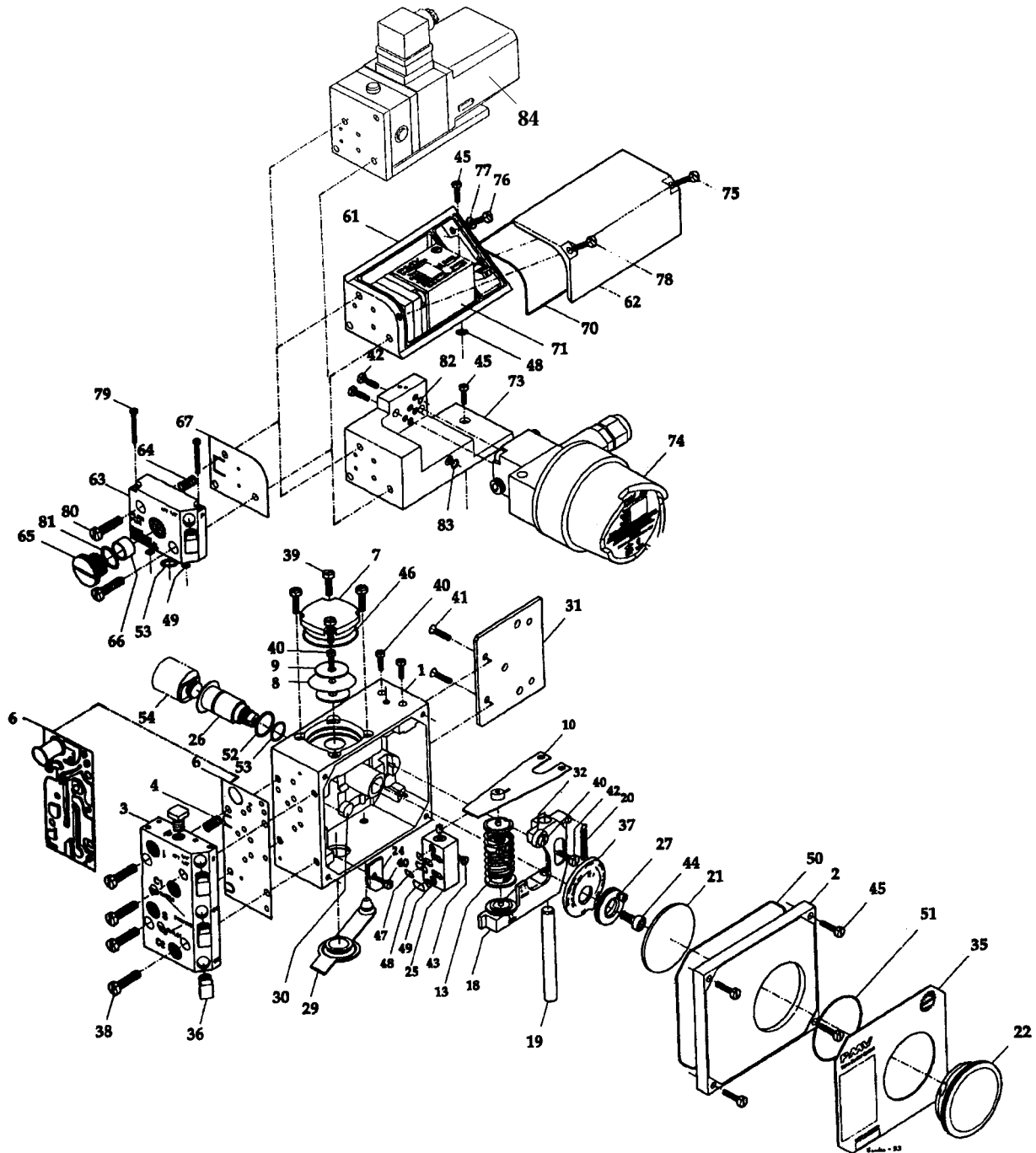

18. Spare part list

98.9

Pos	Part no	Qty	Description
1		1	Housing
2	P5-2	1	Front Cover incl. O-ring
3	P5-AS3N	1	Connecting block NPT 1/4" assembly
3	P5-AS3G	1	Connecting block G 1/4" assembly
4	P5-4	1	Relief valve spring
6	P5-6P	1	Gasket for P5
6	P5-6EP	1	Gasket for EP5
7	P5-7	1	Diaphragm cover incl. O-ring
8	P5-8	1	Diaphragm
9	P5-9	2	Diaphragm washer
10	P5-10	1	Balance arm
13	P5-AS13/315	1	Feedback spring 3-15 psi assembly
13	P5-AS13/630	1	Feedback spring 6-30 psi assembly
18	P5-18	1	Lower arm assembly
19	P5-19	1	Rod
20	P5-20	1	Spring
21	P5-21A	1	Indicator Arrow
21	P5-21F	1	Indicator Flag
21	P5-21P	1	Indicator Pointer
22	P5-22T	1	Indicator cover Transparent incl. O-ring
22	P5-22F	1	Indicator cover Flag incl. O-ring
22	P5-22B	1	Indicator cover Blind incl. O-ring
24	P5-24	1	Twist stop
25	P5-25	1	Pilot valve incl. O-rings
26	P5-26	1	Shaft incl. O-rings, screw
27	P5-27	1	Cam locking nut incl. screw
29	P5-29	1	Zero cover
30	P5-30	1	Cover
31	P5-31	1	Mounting adapter, incl screws
32	P5-32	1	Ball bearing
35	P5-xx/xx	1	Identification cover
36	12047N	4	Plug NPT 1/8"
36	12047G	4	Plug 1/8" G
37	P5-Kxx	1	Cam
38-45, P5-Screws		1	Screw set P5/EP5
75-80			
46-53 P5-Seal NBR		1	O-ring set P5/EP5
81-83, 6, 67, 70			Nitrile, NBR
46-53 P5-Seal Q		1	O-ring set P5/EP5
81-83, 6, 67, 70			Silicone, Q
54	P5-Sxx	1	Spindle adaptor

I/P UNIT Part list.

61		1	I/P box
62	E5-2	1	I/P cover incl. screws
63	E5-AS3N	1	I/P nose NPT 1/4" assembly
63	E5-AS3G	1	I/P nose G 1/4" assembly
64	P5-4	1	Relief valve spring
65	E5-5	1	Filter plug incl. Filter 66, O-ring, 81
66	E5-6	1	Filters (5 per package)
67	E5-7	1	Gasket I/P
71	E5-STD	1	I/P converter
73	E5 N-AS 11	1	Mounting bracket Round I/P
	E5 G-AS 11		incl. screws, O-rings, I/P Nose
74	FU-STD	1	Enclosure incl. I/P converter Std.
74	E5-EX/EU	1	Enclosure incl. I/P converter, flameproof Cenelec
74	E5-EX/US	1	Enclosure incl. I/P converter, Explosionproof FM, CSA
84	E5-FS	1	I/P converter fail in last position incl. bracket





(1) KONFORMITÄTSBESCHEINIGUNG

(2) PTB Nr. Ex-94.C.2071 X

(3) Diese Bescheinigung gilt für das elektrische Betriebsmittel

I/P-Converter Typ Doc. 900826

(4) der Firma Palmsternas Instrument AB
S-113 53 Stockholm

(5) Die Bauart dieses elektrischen Betriebsmittels sowie die verschiedenen zulässigen Ausführungen sind in der Anlage zu dieser Konformitätsbescheinigung festgelegt.

(6) Die Physikalisch-Technische Bundesanstalt bescheinigt als Prüfstelle nach Artikel 14 der Richtlinie des Rates der Europäischen Gemeinschaften vom 18. Dezember 1975 (76/117/EWG) die Übereinstimmung dieses elektrischen Betriebsmittels mit den harmonisierten Europäischen Normen

Elektrische Betriebsmittel für explosionsgefährdete Bereiche

EN 50 014:1977 + A1...A5 (VDE 0170/0171 Teil 1/1.87) Allgemeine Bestimmungen
EN 50 020:1977 + A1...A2 (VDE 0170/0171 Teil 7/1.87) Eigensicherheit "i"

nachdem das Betriebsmittel mit Erfolg einer Bauartprüfung unterzogen wurde. Die Ergebnisse dieser Bauartprüfung sind in einem vertraulichen Prüfprotokoll festgelegt.

(7) Das Betriebsmittel ist mit dem folgenden Kennzeichen zu versehen:

EEx ia IIC T6

(8) Der Hersteller ist dafür verantwortlich, daß jedes derart gekennzeichnete Betriebsmittel in seiner Bauart mit den in der Anlage zu dieser Bescheinigung aufgeführten Prüfungsunterlagen übereinstimmt und daß die vorgeschriebenen Stückprüfungen erfolgreich durchgeführt wurden.

(9) Das elektrische Betriebsmittel darf mit dem hier abgedruckten gemeinschaftlichen Unterscheidungszeichen gemäß Anhang II der Richtlinie des Rates vom 6. Februar 1979 (79/196/EWG) gekennzeichnet werden.

Im Auftrag

Braunschweig, 21.06.1994



Dr.-Ing. Johannsmeyer
Oberregierungsrat

Prüfbescheinigungen ohne Unterschrift und ohne Dienstsiegel haben keine Gültigkeit.

Die Bescheinigungen dürfen nur unverändert weiterverbreitet werden.
Auszüge oder Änderungen bedürfen der Genehmigung der Physikalisch-Technischen Bundesanstalt, Bundesallee 100, Postfach 33 45, D-3300 Braunschweig

ANLAGE zur Konformitätsbescheinigung PTB Nr. Ex-94.C.2071 X

Der I/P-Converter Typ Doc. 900826 dient zur Umformung eines eingepreßten Gleichstromes zwischen 0 und 20 mA in einen proportionalen Druck.

Als Druckmedien dürfen nur nichtbrennbare Gase verwendet werden.

Der zulässige Umgebungstemperaturbereich beträgt je nach Temperaturklasse -55 °C bis +85 °C.

Elektrische Daten

Steuerstromkreis in Zündschutzart Eigensicherheit EEx ia IIC
(Kabel) nur zum Anschluß an bescheinigte eigensichere Stromkreise
mit dem Höchstwert I_k gemäß folgender Tabelle:

Temperaturklasse	Eingangsstrom I_k	max. Umgebungstemperatur
T6	50 mA	60 °C
T6	60 mA	55 °C
T5	60 mA	70 °C
T4	60 mA	85 °C
T5	100 mA	55 °C
T4	100 mA	85 °C
T5	120 mA	45 °C
T4	120 mA	80 °C
T4	150 mA	70 °C

Die wirksame innere Kapazität und Induktivität sind vernachlässigbar klein.

Prüfungsunterlagen

1. Konformitätsbescheinigung PTB Nr. Ex-93.C.2104 X
2. Zeichnung Nr. 900853
unterschieden am 09.03.1994

Besondere Bedingung

Beim Einsatz des I/P-Converters Typ Doc. 900826 im Temperaturbereich von -55 °C bis -20 °C ist dieser durch Einbau in ein zusätzliches Gehäuse in einer Schutzart von mindestens IP 20 nach IEC 529 vor Schlägeinwirkung zu schützen.

Im Auftrag

Braunschweig, 21.06.1994



Dr.-Ing. Johannsmeyer
Oberregierungsrat

Approvals E5-EX/EU

Bergbau-Versuchsstrecke

BVS

1. Nachtrag zur Konformitätsbescheinigung BVS 93.C.2022 X

der PMW Palmstiernas Instrument AB S-11357 Stockholm/Schweden

I/P-Stellumformer Typ Doc. 900 771

Kennzeichen: EEX d IIB T4, T5 oder T6

Der I/P-Stellumformer kann auch nach den unten aufgeführten Prüfungsunterlagen ausgeführt sein:

Änderungen gemäß 1. Nachtrag zu BVS 90.C.2016 X

Der I/P-Stellumformer kann in Verbindung mit einer für diesen Temperaturbereich zugelassenen Metall-Leitungseinführung (Kennzeichen EEX d IIB oder EEX d IIC) auch bei einer Umgebungstemperatur -40 °C eingesetzt werden.

Der Stellumformer kann in Verbindung mit der Leitungseinführung Typ 1020 11 26 (IMEX 88 B.103.748) bei einer Umgebungstemperatur -30 °C eingesetzt werden.

Im Hinblick auf die höchstzulässige Umgebungstemperatur behalten die Angaben gemäß BVS 93.C.2022 X ihre Gültigkeit.

Änderungen gemäß 2. Nachtrag zu BVS 90.C.2016 X

Der I/P-Stellumformer wird in geänderter Bauform auch mit dem Kennzeichen

EEX d IIC T4, T5 oder T6

geliefert. Der Anschluß erfolgt mit für den jeweiligen Temperaturbereich zugelassenen Leitungseinführungen (Kennzeichen EEX d IIC) und geeigneten Leitungen.

Die Nennstromstärke des I/P-Stellumformers kann, in nichteigen-sicherer Ausführung, bis 50 mA betragen; der Hinweis in der Beschilderung auf Zündschutzart Eigensicherheit entfällt dann.

Bergbau-Versuchsstrecke

BVS

Seite 2/3 zum 1. Nachtrag zur KB BVS 93.C.2022 X vom 05.08.1994

Änderungen gemäß 3. Nachtrag zu BVS 90.C.2016 X

Das Gehäuse des Stellumformers wird mit geringfügigen Änderungen versehen.

Weitere Änderungen

Das Gehäuse des Stellumformers kann mit einem geänderten Steuerkopf (Typ Doc. 900826; PTB Nr. Ex-94.C.2071 X) bestückt werden. Die Zuordnung von Kurzschlussstromstärke, Umgebungstemperatur und Temperaturklasse ändert sich wie folgt:

Umgebungstemperatur	bis 60	55	70	85	55	85	45	80	70	°C
Kurzschlussstromstärke	50	60	60	100	100	120	120	150	150	mA
Temperaturklasse	T6	T6	T5	T4	T5	T4	T5	T4	T5	T4

Prüfungsunterlagen

1 Nachträge Nr. 1, Nr. 2 und Nr. 3 zu BVS 90.C.2016 X

2 Zeichnung Nr.	vom	unterschieden am
900867	04.07.94	28.07.94
900868	04.07.94	28.07.94

Kennzeichnung

Die Kennzeichnung muß gut sichtbar, lesbar und dauerhaft sein; sie muß die folgenden Angaben umfassen:

- Name des Herstellers oder sein Warenzeichen
Typ Doc. 900 771
EEX d IIB T4, T5 oder T6 bzw.
EEX d IIC T4, T5 oder T6
Fertigungsnummer
BVS Nr. 93.C.2022 X

2 Die Kennzeichnung, die normalerweise für das betreffende elektrische Betriebsmittel in den Konstruktionsnormen vorgesehen ist

3 Kennzeichnung des Gewindes der Leitungseinführungsböhrung bei nicht metrischem Gewinde

Bergbau-Versuchsstrecke

BVS

Seite 3/3 zum 1. Nachtrag zur KB BVS 93.C.2022 X vom 05.08.1994

Besondere Auflagen/Bestimmungen für die sichere Anwendung

- gemäß 7.1 BVS 93.C.2022 X
- gemäß 7.2 BVS 93.C.2022 X

3 Der Betrieb des Stellumformers in explosionsgefährdeten Bereichen mit einer Umgebungstemperatur unter -20 °C in Verbindung mit einer hierfür geeigneten Leitungseinführung ist nur mit für diesen Temperaturbereich geeigneter Anschlußleitung zulässig.

44329 Dortmund, den 05.08.1994
BVS-Dr. We/Tc A 9400325

DMT-Gesellschaft für Forschung und Prüfung mbH
Fachstelle für Sicherheit elektrischer Betriebsmittel
Bergbau-Versuchsstrecke



Dr. Dill

Der Sachverständige
Dr. Wenzel

Approvals E5-IS/US & E5-EX/US 1

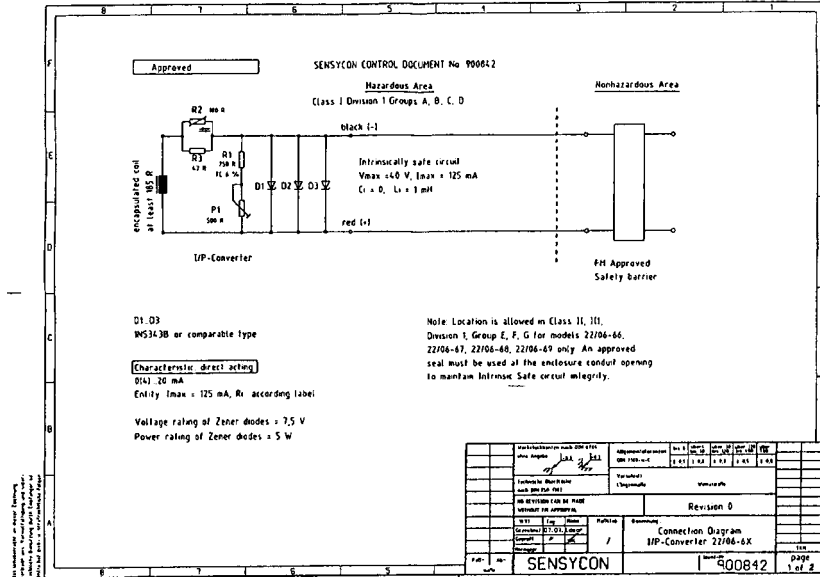

1151 Boston Providence Turnpike
P.O. Box 9102
Norwood, Massachusetts 02062
Telephone (617) 762-4300
Telex 924415



Factory Mutual Research
PRIVATE LABELER AGREEMENT

This Agreement is made by and between Factory Mutual Research Corporation, (herein called FMRC), and SENSYCON GmbH, Hannover, Germany (herein called the Manufacturer), and Palmis Lasermas Inst AB, Sweden (herein called the Private Labeler).

The Manufacturer is making the below described approved or listed product(s) to be marked or labelled with the Private Labelers identification as herein set forth.

MANUFACTURER'S		FMRC		GENERIC		PRIVATE LABELER	
Trade Name	Product Identification	Product Identification	Identification	Description	Trade Name	Product Identification	Product Identification
I/P Converter	22/06-65	1987 AX	I/P Converter	I/P Converter	E5-IS/US		
	22/06-67	1987 AX	I/P Converter	I/P Converter	E5-EX/US		
	22/06-66	1987 AX	I/P Converter	I/P Converter	E5-EX/US-SS		

In consideration of extending FMRC Approval or Listing of the above product(s) to be marketed by the Private Labeler herein named, the Private Labeler is authorized to indicate such approval or listing as stated by the referenced job identification, and the Manufacturer and Private Labeler agree to the terms stated on the reverse side of this Agreement.

SENSYCON Corporation
Palmis Lasermas Inst AB
Manufacturer

George A. Orrison, IV
Name
Roland Wedsbrand
Name
Vice President
Title
210A Fort Collier Road
Tulington 1E
Winchester, VA 22603
Address
November 15, 1993
Date
November 25, 1993
Date

Factory Mutual Research Corporation
Palmis Lasermas Inst AB
Manufacturer

Larry D. Chase
Signature
Larry D. Chase
Name
Vice President
Title
November 3, 1993
Date

SENSYCON
Hermann & Braun

02.02.1994
Dr. Karte

Declaration
issued by
SENSYCON GmbH
Hackethalstr. 7
D-30179 Hannover

We hereby state that by
Certification Record Nr. 83572, issued on September 21, 1993

Canadian Standards Association,
we are authorized to place labels with CSA-Marks on PMV devices
model Nr. E5-IS/US, E5-EX/US, E5-EX/US-SS.

SENSYCON GmbH
i.V. Dr. Th. Karte
Hackethalstraße 7 · 30173 Hannover
Postfach 229 · 30052 Hannover

30179 Hannover
Hermannstr. 7
30173 Hannover
Business (0511) 6982-0
Telefax (0511) 6982-1
Telex 8 927 145 army of
Telex 41 626 10 by 41

30179 Hannover
Hermannstr. 7
30173 Hannover
Business (0511) 6982-0
Telefax (0511) 6982-1
Telex 8 927 145 army of
Telex 41 626 10 by 41

30179 Hannover
Hermannstr. 7
30173 Hannover
Business (0511) 6982-0
Telefax (0511) 6982-1
Telex 8 927 145 army of
Telex 41 626 10 by 41

Approvals E5-IS/US & E5-EX/US 2

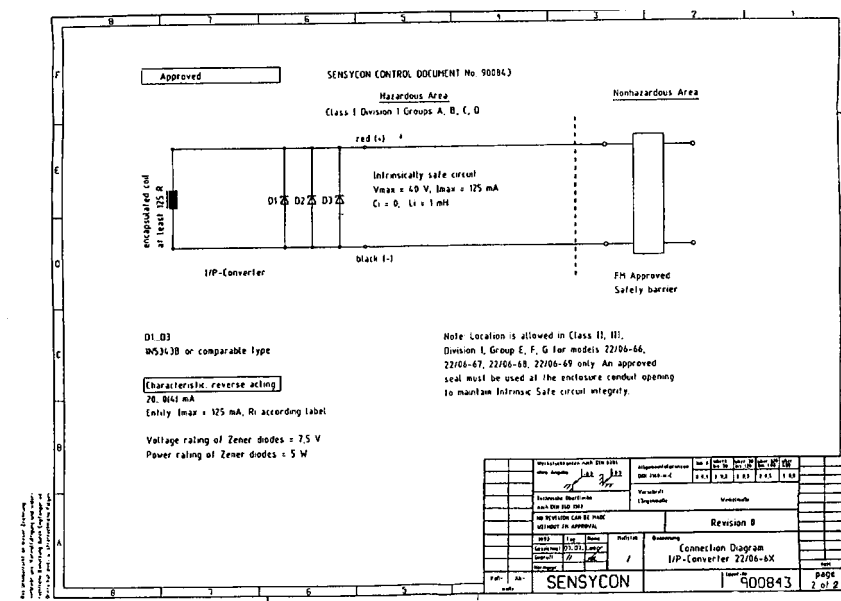
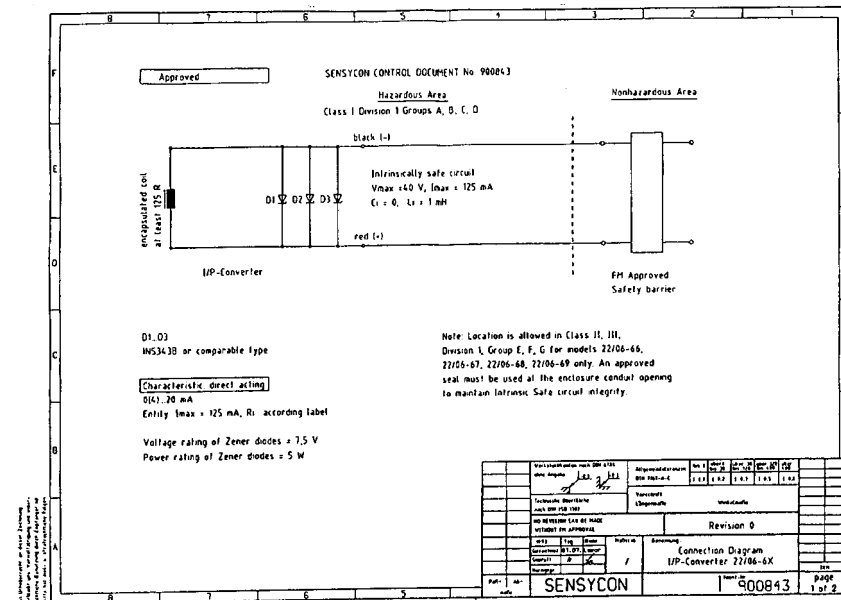
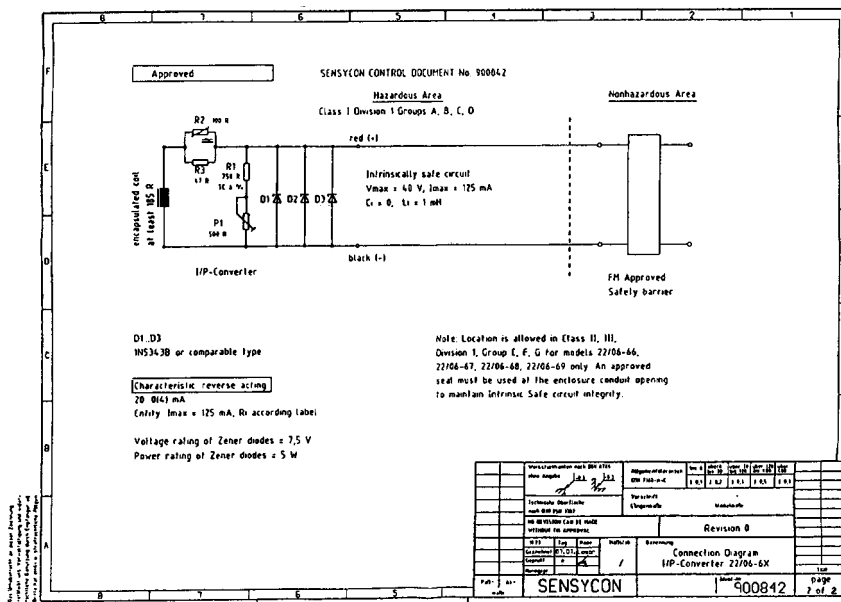

Approvals EP5-IS (I/P-converter with white label)

CSA APPROVED VERSION

Intrinsically Safe Approval for Class I, Groups A, B, C and D with a temperature classification of:

T4A at 85°C
T6 at 55°C

The unit must be installed according to drawing 96-111.

Division 2 Approval for Class I, Division 2, Groups A, B, C and D

These devices are certified as components for use in a suitable enclosure subject to the acceptance of CSA or the Inspection authority having jurisdiction.

GENELEC APPROVED VERSION

Intrinsically Safe Approval as E Ex ia IIC T4 at 80°C T6 at 55°C

Certificate number Ex96D2004X Ambient -40°C to 80°C (except for T6)

The following table applies for Is input currents and ambient temperatures

Current Is mA	Maximum Ambient Temperature °C		
	T4	T5	T6
50	80	80	53
60	80	80	47
100	80	80	
120	80	75	
150	80	57	

The unit must be installed alone in a metallic enclosure with
i) a magnesium content of less than 6% by weight.
and ii) a minimum IP rating of IP20

The distance from the terminals to any earthed metal must be greater than 3mm and the circuit must be capable of withstanding a voltage of 500 Vrms to case or earth for one minute.

The unit must be installed according to drawing 96-108.

WARNING!

These instruments must be installed in accordance with local and national codes of practice, especially for hazardous area installations. The instruments are fully isolated from ground and therefore grounding is unnecessary for functional purposes. However, grounding may be necessary to conform to installation codes.

HAZARDOUS AREA VERSIONS

The instrument is available in versions suitable for use in hazardous areas. The hazardous area versions carry information on their certification on a special label. This gives an indication to the correct areas of use.

WARNING!

Installation of any hazardous area equipment should be made in accordance with hazardous area installation codes and also of course to the installation to the installation and operating instructions provided. The manufacturer cannot be held responsible for incorrect installation or any customer modifications to, or repair of, a certified instrument as this may invalidate the certified design. If a certified instrument should fail, no attempt should be made by the user to effect repair. The unit should be returned to the factory.

FM APPROVED VERSION

Intrinsically Safe Approval for Class I, Division 1, Groups A B C D hazardous locations with a temperature classification of:

T4 ambient 40°C
T3B ambient 70°C
T3A ambient 85°C
T6 ambient 55°C

These units must be installed in accordance with:

- The National Electrical Code (ANSI/NFPA 70) and ANSI/ISA RP 12.6, "Installation of Intrinsically Safe Instrument Systems in Class 1 Hazardous (Classified) Locations".
- The installation drawing 96-114.
- The Installation and Operating Instructions provided with each unit.
- The I/P shall be installed in a properly grounded metal enclosure.



96-114 ISSUE 'C'-FM IS SYSTEM
DO NOT SCALE DRAWING. IF IN DOUBT ASK.

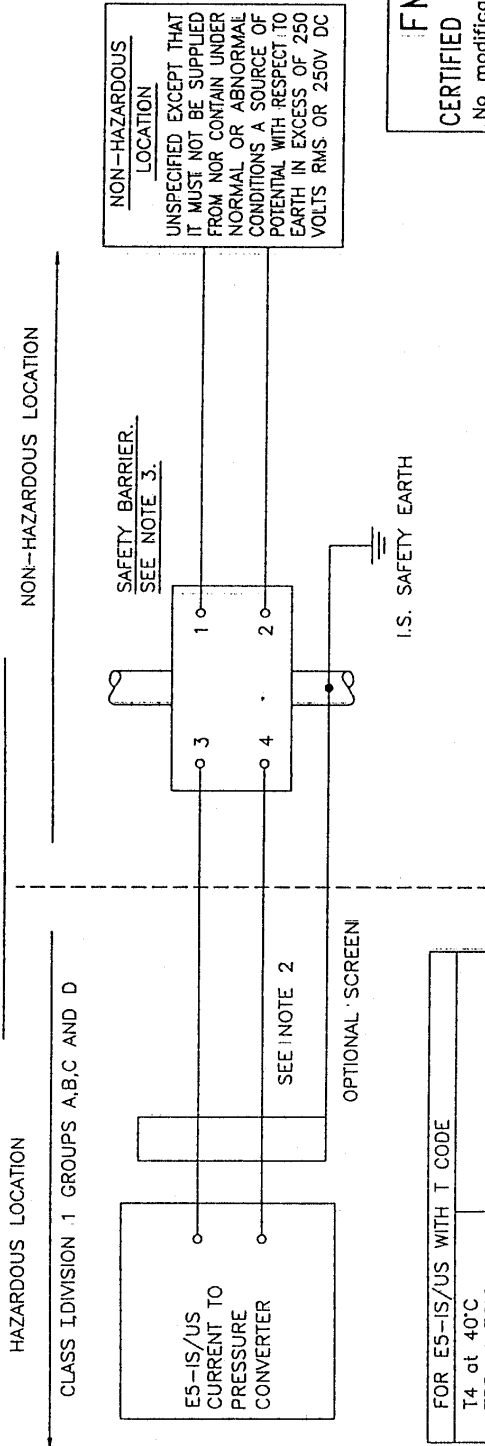

NON-HAZARDOUS LOCATION
UNSPECIFIED EXCEPT THAT IT MUST NOT BE SUPPLIED FROM NOR CONTAIN UNDER NORMAL OR ABNORMAL CONDITIONS A SOURCE OF POTENTIAL WITH RESPECT TO EARTH IN EXCESS OF 250 VOLTS RMS OR 250V DC

SAFETY BARRIER
SEE NOTE 3.

NON-HAZARDOUS LOCATION

HAZARDOUS LOCATION

CLASS I DIVISION 1 GROUPS A,B,C AND D

SEE NOTE 2

OPTIONAL SCREEN

I.S. SAFETY EARTH

FM
CERTIFIED PRODUCT
No modifications are permitted without reference to FMRC.

3. ANY POSITIVE POLARITY SAFETY BARRIER APPROVED BY FMRC FOR GROUPS A,B,C AND D WHOSE OUTPUT PARAMETERS ARE :-

FOR E5-IS/US WITH T CODE	
T4 at 40°C T3B at 70°C T3A at 85°C	T6 at 55°C
V _{max} or V _t ≥ 12V and ≤ 30V I _{sc} or I _t ≤ 96mA P _{max} ≤ 0.8W eg. MIL 728 P & F Z42B/Ex	V _{oc} or V _t ≥ 12V and ≤ 28V I _{sc} or I _t ≤ 46.7mA P _{max} ≤ 0.33W

NOTES

1. THE ELECTRICAL CIRCUIT IN THE HAZARDOUS AREA MUST BE CAPABLE OF WITHSTANDING AN A.C. TEST VOLTAGE OF 500 VOLTS R.M.S. TO EARTH OR FRAME OF THE APPARATUS FOR 1 MINUTE.

2. CABLE CAPACITANCE AND INDUCTANCE PLUS THE I.S. APPARATUS UNPROTECTED CAPACITANCE (C_i) AND INDUCTANCE (L_i) MUST NOT EXCEED THE ALLOWED CAPACITANCE (C_o) AND INDUCTANCE (L_o) INDICATED ON THE ASSOCIATED APPARATUS.

THE OUTPUT CURRENT MUST BE LIMITED BY A RESISTOR R SUCH THAT $R \geq V_{oc} / I_{sc}$

4. THE INSTALLATION INCLUDING THE BARRIER EARTHING ARRANGEMENTS MUST COMPLY WITH THE INSTALLATION REQUIREMENTS OF THE COUNTRY OF USE, ie ANSI/ISA RP12.6 (INSTALLATION OF INTRINSICALLY SAFE SYSTEMS FOR HAZARDOUS (CLASSIFIED) LOCATIONS) AND THE NATIONAL ELECTRICAL CODE. INSTALLATION MUST BE IN ACCORDANCE WITH THE MANUFACTURERS GUIDELINES.

ISS NO.	DATE	ISS NO.	DATE	ISS NO.	DATE	WHERE USED	CHECKED	APPROVED	MATERIAL	FINISH	T	N.T.S. SCALE				
D (3084)	14-08-96															
C (3084)	06-06-96															
B (3084)	16-7-96															
A	20-5-96															
UNSPECIFIED TOLERANCES X ±0.5mm X.XX ±0.15mm X X ±0.2mm ANGLES 90° REMOVE ALL BURRS & SHARP EDGES TO 0.25 MAX SURFACE FINISH UNLESS OTHERWISE STATED											WATSON SMITH LTD 1000 S. CAROLINA ST. TEL 013 245 7887 THIS DRAWING IS CONFIDENTIAL. COPYRIGHT © 1996 DRAWN BY: B3008		TYPE E5-IS/US PMV IS FM SYSTEM TITLE		96-114 DRG NO.	

DO NOT SCALE DRAWING, IF IN DOUBT ASK.

96-111 ISSUE 'E' - CSA IS SYSTEM

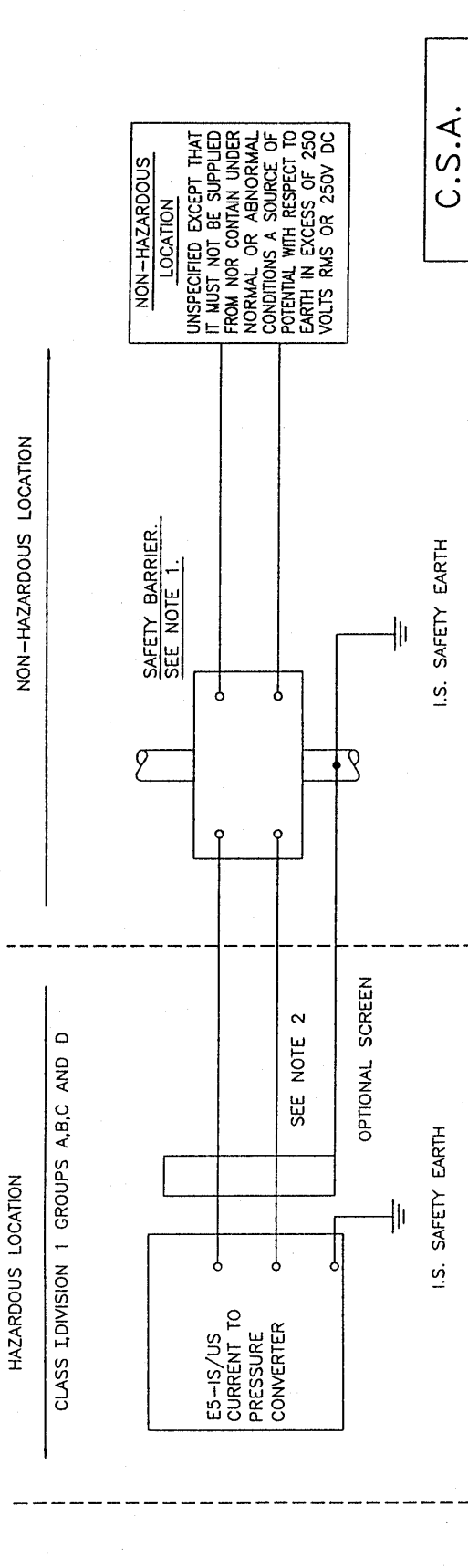

C.S.A.
CERTIFIED PRODUCT
 No modifications are permitted without reference to C.S.A.

TEMPERATURE CODE	(MAX) AMBIENT
T4A	85°C
T6	55°C

NOTES

1. ANY POSITIVE POLARITY SAFETY BARRIER APPROVED BY C.S.A. FOR GROUPS A,B,C AND D WHOSE OUTPUT PARAMETERS ARE :-
 28V (max)
 300 Ohms (min)
 eg. MTL 728 + P & F Z428/Ex
2. THE INSTALLATION INCLUDING THE BARRIER EARTHING ARRANGEMENTS MUST COMPLY WITH THE CANADIAN ELECTRICAL CODE PART I
3. THE DEVICE IS ALSO SUITABLE FOR CLASS II, GROUPS E,F,G, & CLASS III HAZARDOUS LOCATIONS WHEN INSTALLED IN A SUITABLE DUST EXCLUDING ENCLOSURE.
4. SUBSTITUTION OF COMPONENTS MAY IMPAIR INTRINSIC SAFETY & DIV 2 SUITABILITY.
 LA SUBSTITUTION DE COMPOSANTS PEUT COMPROMETTRE LA SECURITE INTRINSEQUE ET DIV 2.
5. THE TYPE E5-IS/US TERMINALS WHEN SUPPLIED AS FLYING LEADS MUST BE SUITABLY SECURED TO AN ENCLOSURE WITH AN APPROPRIATE FASTENER.

E 3084	18-9-96	ISS NO.	DATE	ISS NO.	DATE	UNLESS OTHERWISE STATED	WHERE USED	DRAWN	DATE APPROVED	FINISH	MATERIAL	WATSON SMITH LTD GROSS CHANCELLOR ST. LEEDS, LS99PT 5T. TEL:0113 245 7587 DRAWN TO ESC08	TYPE E5-IS/US PMV IS C.S.A. SYSTEM	T	N.T.S.
	3-9-96													DISC	SCALE
C 3084	21-06-96														96-111
B 3068	3-7-96														DRG NO.
A	20-5-96														

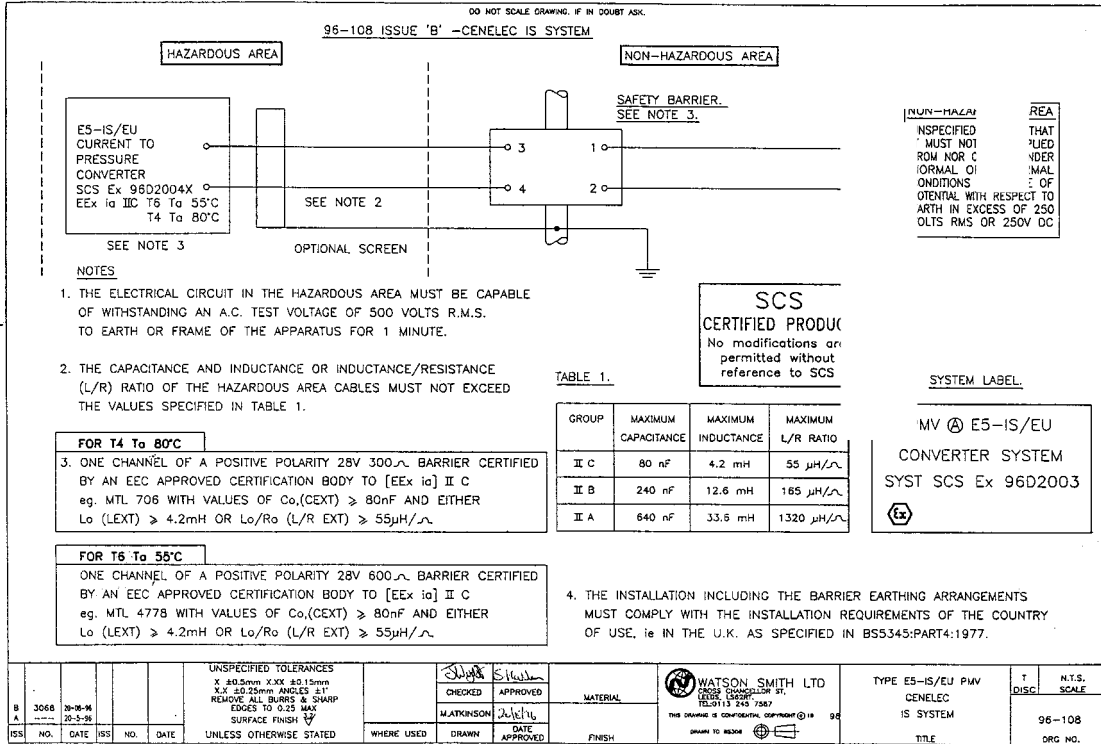

Translation

EC-Type Examination Certificate

- Directive 94/9/EC -
Equipment and protective systems intended for use in potentially explosive atmospheres

DMT 02 ATEX E 121 X

- Equipment: EP-converter type Doc. 980771
- Manufacturer: ABB Automation Products GmbH
- Address: D 31425 Minden
- The design and construction of this equipment and any acceptable variation thereto are specified in the schedule to this type examination certificate.
- The certification body of Deutsche Montan Technologie GmbH, notified body no. 0018 in accordance with Article 9 of the Directive 94/9/EC of the European Parliament and the Council of 23 March 1994, certifies that this equipment has been found to comply with the Essential Health and Safety Requirements relating to the design and construction of equipment and protective systems intended for use in potentially explosive atmospheres, given in Annex II to the Directive. The examination and test results are recorded in the test and assessment report RVR PP 01.206T EG.
- The Essential Health and Safety Requirements are covered by compliance with:
EN 50114: 1997+A1-A2 General requirements
EN 50118: 2000 Hazardous enclosure
- If the sign "X" is placed after the certificate number, it indicates that the equipment is subject to special conditions for safe use specified in the schedule to this certificate.
- This EC-Type Examination Certificate relates only to the design, examination and tests of the specified equipment in accordance with Directive 94/9/EC. Further requirements of the Directive apply to the manufacturing process and supply of this equipment. These are not covered by this certificate.
- The marking of the equipment shall include the following:

II 2G EEx d IIC T4/T5/T6
Deutsche Montan Technologie GmbH
Essen, dated 28. June 2002

Signed Jockers
DMT-Certification body

Signed Eickhoff
Head of special services unit

