

Dipl.-Ing. Herwarth Reich GmbH

D2C
Designed to Customer

MULTI MONT

- SELLA

- DEKA

- GIGANT

Torsionally flexible claw couplings

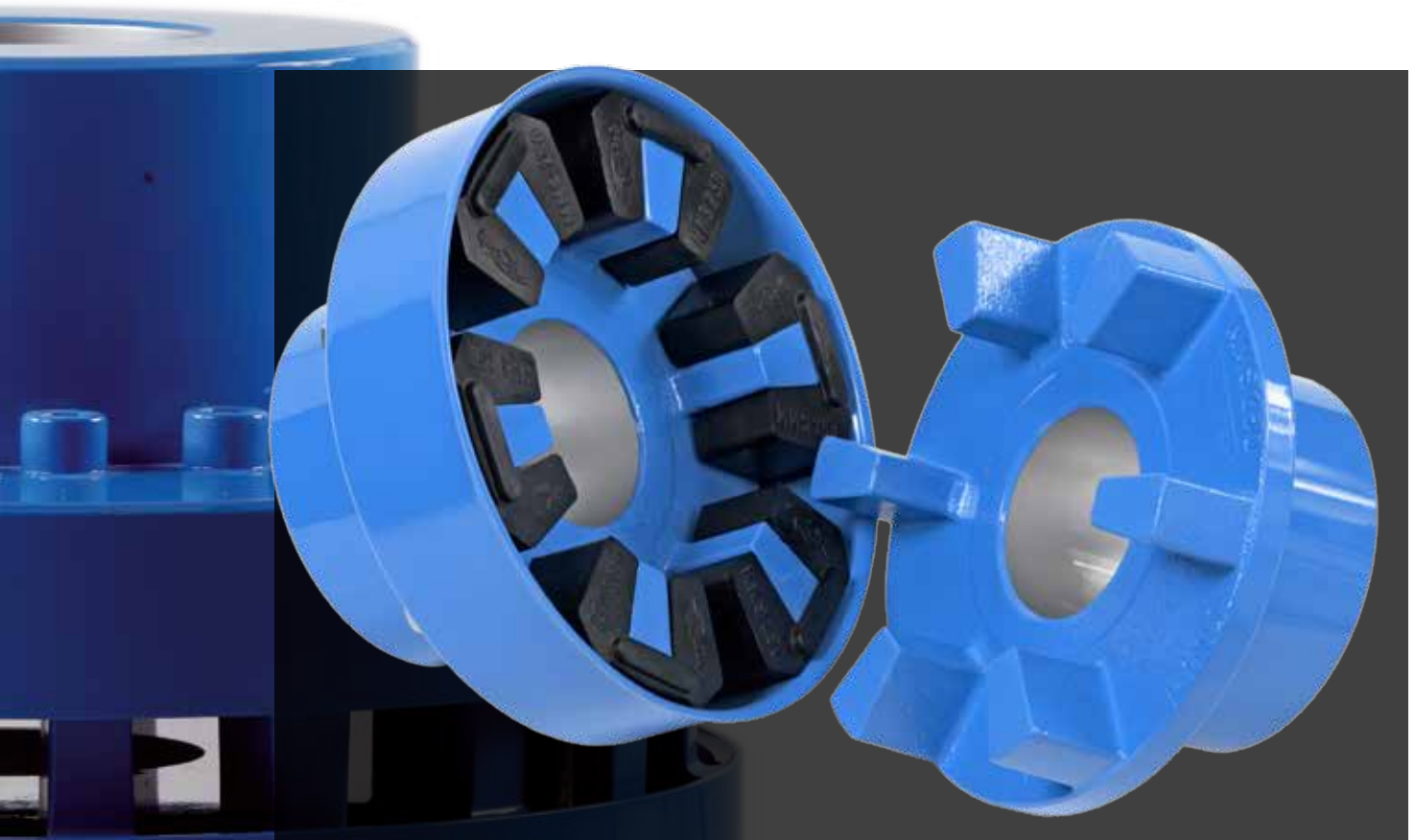

Your drive is our strength. Your strength is our drive.



Contents

	Page
General technical description	3
Standard types	5/6
Special types	7
Technical Data	7
Material	8
Selection of the proper coupling size	9
Assignment of the load classification factors to the type of driven machine	10
Assignment to IEC standard motors	11
MULTI MONT SELLA with taper bush, series MMS-T...W.....	12
MULTI MONT SELLA shaft couplings, series MMS...W	13
MULTI MONT SELLA flange couplings, series MMS...F1	14
MULTI MONT SELLA separable shaft couplings, series MMS...T	15
MULTI MONT SELLA brake disc couplings, series MMS...WBS.....	16
MULTI MONT SELLA brake disc couplings, series MMS...TBS	17
MULTI MONT SELLA brake drum couplings, series MMS...WBT	18
MULTI MONT SELLA brake drum couplings, series MMS...TBT.....	19
MULTI MONT SELLA brake drum couplings, series MMS...F1 BT.....	20
Weights and moments of inertia	21
MULTI MONT DEKA standard types, series MMD	22
MULTI MONT GIGANT standard types, series MMG	23
Mounting instructions and alignment tolerances	24
Technical note / Safety instructions	26

D2C – Designed to Customer



The principle of Designed to Customer describes the recipe for success of REICH-KUPPLUNGEN: Utilizing our product knowledge, our customers are supplied with couplings which are developed and tailor-made to their specific requirements. The designs are mainly based on modular components to provide effective and efficient customer solutions. The unique form of close cooperation with our partners includes consultation, design, calculation, manufacture and integration into existing environments. Adapting our manufacturing to customer-specific production and utilizing global logistics concepts provides better after sales service - worldwide. This customer-oriented concept applies to both standard products and production in small batch sizes.

The company policy of REICH-KUPPLUNGEN embraces, first and foremost, principles such as customer satisfaction, flexibility, quality, prompt delivery and adaptability to the requirements of our customers.

REICH-KUPPLUNGEN supplies not only a coupling, but a solution: Designed to Customer.

Edition June 2014

Proprietary notice pursuant to ISO 16016 to be observed:

The present MULTI MONT SELLA edition renders parts of the previous MULTI MONT SELLA catalogues obsolete. All dimensions in millimeters. We reserve the right to change dimensions and / or design details without prior notice.

The reproduction, distribution and utilization of this document as well as the communication of its contents to others without explicit authorization is prohibited. Offenders will be held liable for the payment of damages. All rights reserved in the event of the grant of a patent, utility model or design. © REICH-KUPPLUNGEN

General technical description

MULTI MONT couplings have been built in series since 1958. This pluggable claw coupling that has been successfully proven over a number of decades has been permanently updated to the state of the art, and the MULTI MONT SELLA, MULTI MONT DEKA and MULTI MONT GIANT series nowadays cover a torque range from 40 to 1 000 000 Nm.

The MULTI MONT product line offers a large variety of different types so that a suitable coupling is available for almost every type of power transmission requirement.

MULTI MONT SELLA nominal torques from 40 to 30 000 Nm



The MULTI MONT SELLA standard series comprises a number of different types. All coupling types allow changing the flexible transmission elements with no need for axial movement of a coupled machine part. The flexible element for the coupling sizes up to and including MMS 63 consists of a split toothed ring which has the single rubber dampers attached to an external belt. All larger coupling sizes are equipped with 6 single saddle elements each for transmission which have two rubber dampers attached to the external belt. The coupling is fitted with a separately screwed-on retaining cap which encloses the periphery of the rubber elements. This screwed connection is not involved in torque transmission. The elements of all coupling sizes can be fitted and removed radially after the retaining caps have been released and withdrawn.

MULTI MONT DEKA

nominal torques from 40 000 Nm to 100 000 Nm

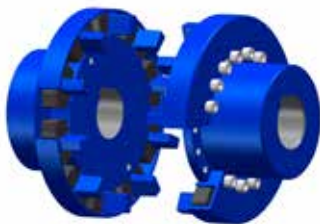

The MULTI MONT DEKA coupling series that is made of spheroidal cast iron as a standard is not only of extremely compact design but also offers a high transmission rate.

The flexible transmission elements are fixed in pockets. During torque transmission, two elements totalling 40 are always subjected simultaneously to compression by one coupling claw.

Using the flange version the flexible transmission elements can be fitted and removed radially.

MULTI MONT GIANT

nominal torques from 40 000 Nm to 1 000 000 Nm



Standardly made of cast iron the MULTI MONT GIANT coupling is available for highest torques up to 1 000 000 Nm.

The MULTI MONT GIANT uses 6 single saddle elements.

The separate retaining cap allows radial fitting of the flexible elements with no need for axial movement of a coupled machine part.

The most important attributes and advantages of MULTI MONT -SELLA, -DEKA, -GIANT:

- compensate for axial-, radial- und angular misalignments
- absorb shocks and vibrations
- are fail-safe and withstand high overloads
- are well suited as plug-in type couplings ensuring ease of assembly and alignment
- allow prompt and easy radial change of the flexible elements by sliding back the retaining cap
- are maintenance-free
- are customizable for almost every type of mounting situation
- easy and simple assembly of the shaft connections thanks to taper bushes

Standard types

Claw coupling

Equipped with a taper bush as a connection element for the shaft. The taper bush is bolted in place in the coupling hub so that a shrink-fit-like connection free from backlash is established between the coupling hub and the shaft after assembly.

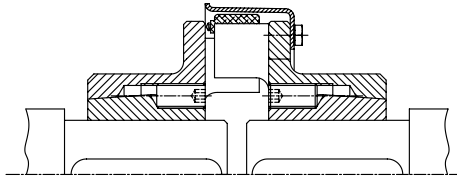
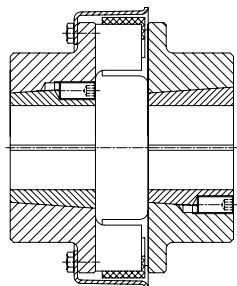

Series: MMS - T... W
up to 12 500 Nm

Shaft couplings

Standard version for connecting two shafts.

The separately screwed-on retaining cap allows changing the flexible elements with no need for axial movement of either of the coupling hubs.

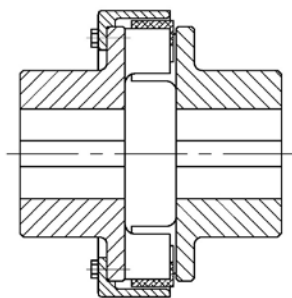

Series: MMS ... W
up to 30 000 Nm

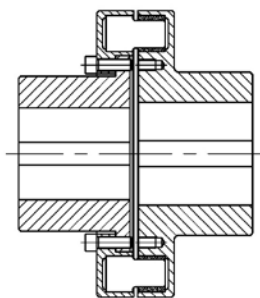

Series: MMD ... WK
up to 100 000 Nm

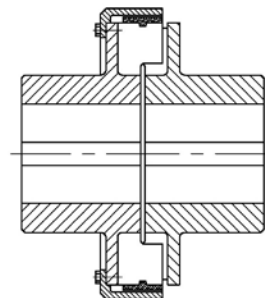

Series: MMG ... W
up to 1 000 000 Nm

Separable flange couplings

This version allows radial assembly of the coupled machines with no need for their axial movement.

The separately screwed-on retaining cap allows changing the flexible elements with no need for axial movement of either of the coupling hubs.

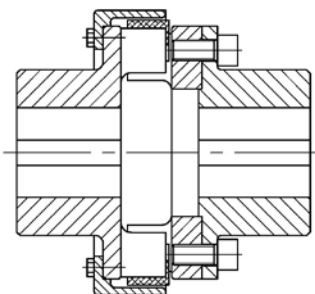

Series: MMS ... T
up to 30 000 Nm

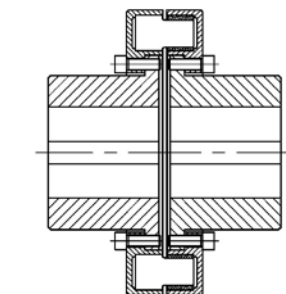

Series: MMD ... TK
up to 100 000 Nm

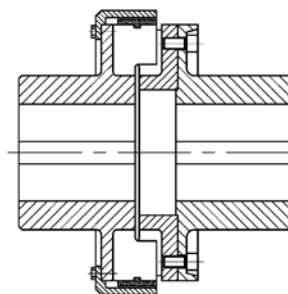

Series: MMG ... T
up to 1 000 000 Nm

Standard types

Flange couplings

For flange-mounting to discs and flywheels.

The separately screwed-on retaining cap allows changing the flexible elements with no need for axial movement of either of the coupling hubs. Different mounting options are available by the use of intermediate flanges.

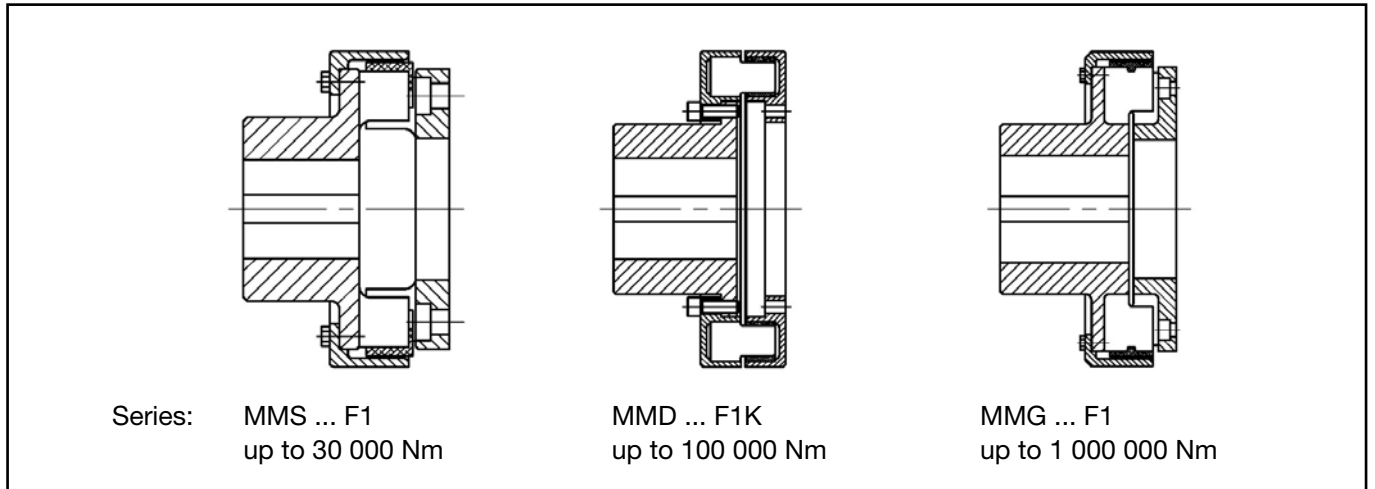

Brake disc couplings

With brake discs for disc clamps. The separable flange coupling TBS allows radial fitting and removal of the brake disc.

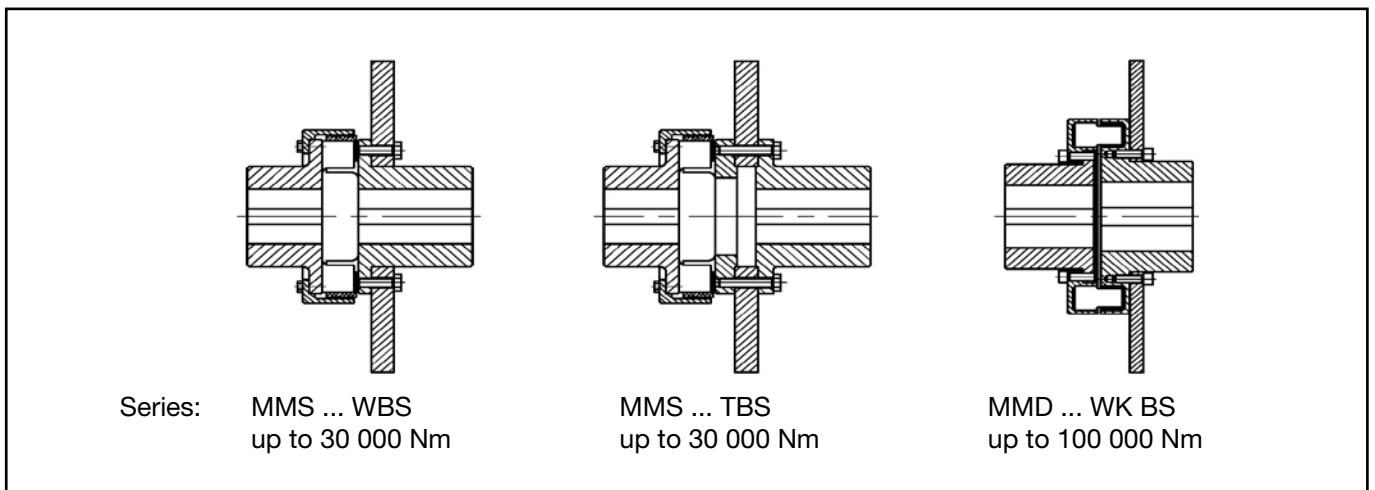

Brake drum couplings

With brake drums for external shoe brakes. Leading dimensions of the brake drum acc. to DIN 15 431.

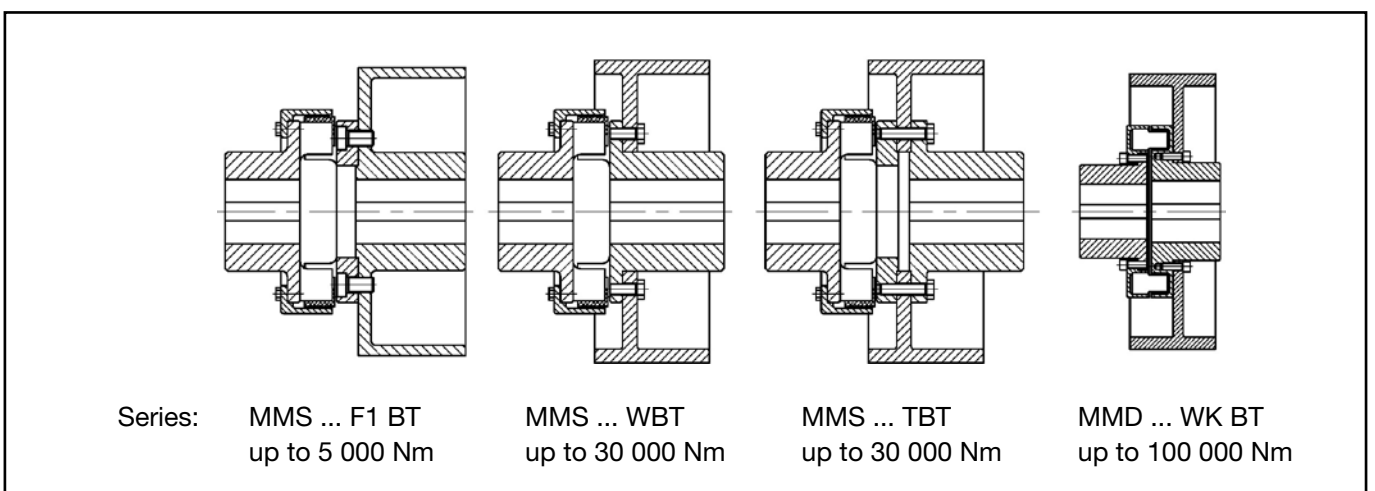

Special types

Double flange couplings

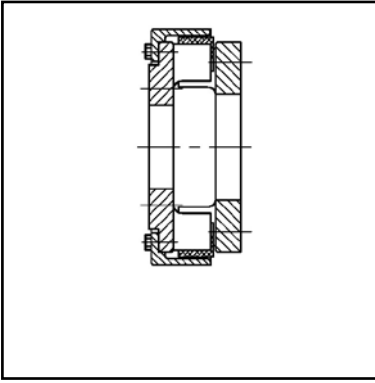

Spacer couplings

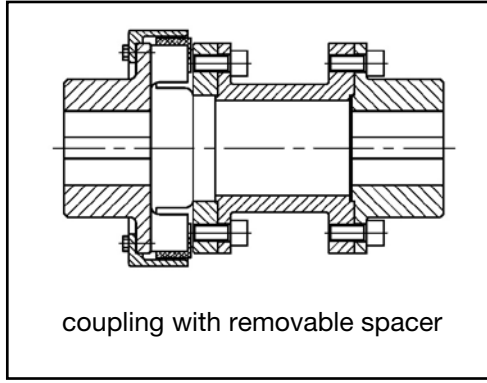

Clutches

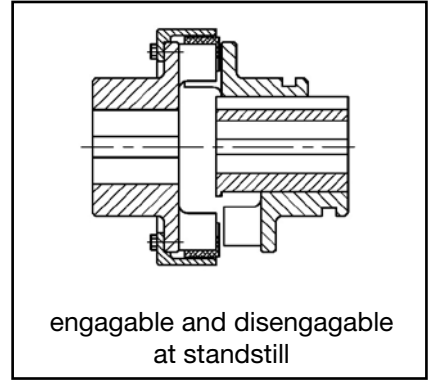

Combination couplings

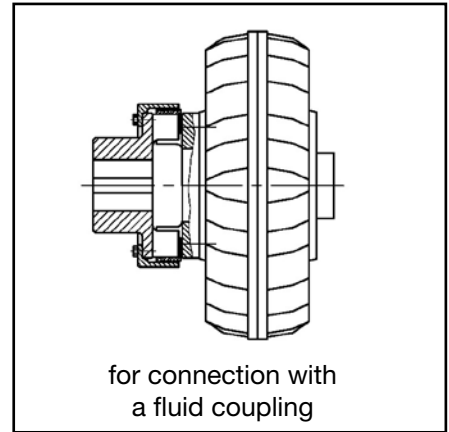
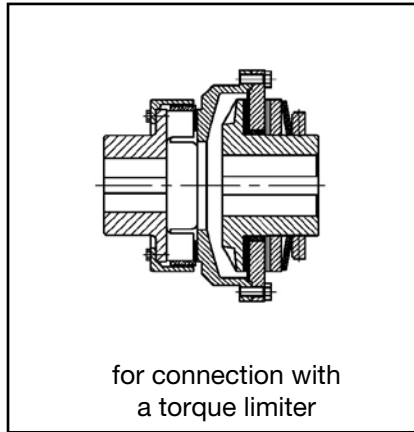
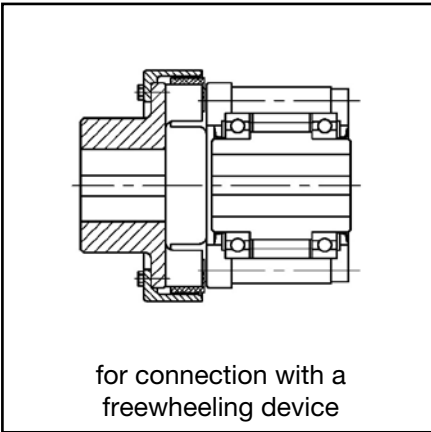

Brake disc and brake drum coupling versions

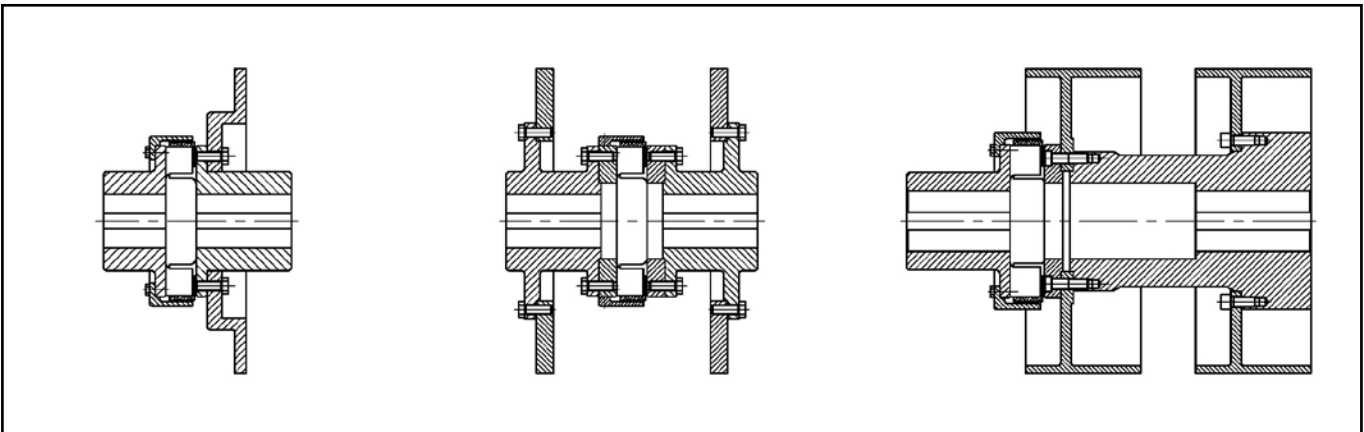

Versions with shrink disc

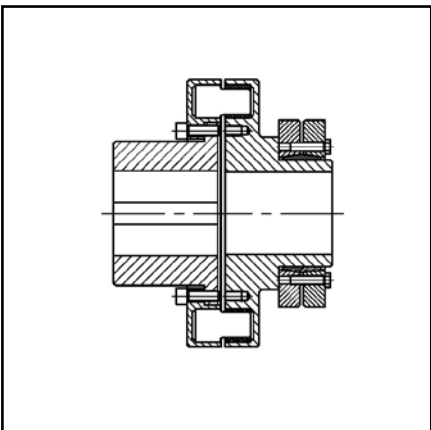

Versions with intermediate shaft in combination with a gear coupling

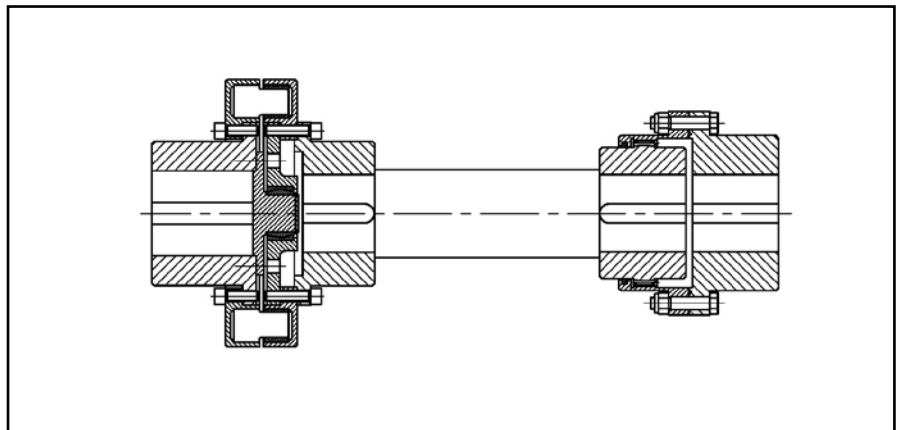

Technical data

The specified torques of T_{KN} and T_{Kmax} comply with the definition for „Flexible shaft couplings DIN 740 part 2“ and apply to the standard types with rubber elements of 75-80° Shore A.

Technical details of other flexible element materials are available on request.

Coupling size	Technical details for standard rubber elements SN								Rel. damp- ing Ψ	Max. *) speed n_{max} rpm	Max. shaft displacement		
	Nominal torque T_{KN} Nm	Maximum torque T_{Kmax} Nm	Continuous vibratory torque T_{KW} (10 Hz) Nm	Dynamic torsional stiffness C_{Tdyn} 10^3 Nm/rad				ΔK_r mm			ΔK_a mm	ΔK_u mm	
				0.25 T_{KN}	0.5 T_{KN}	0.75 T_{KN}	1.0 T_{KN}						
MMS 4-A	40	120	20	0.5	0.7	2	4	1.0	5000	0.5	1.0	1.0	
MMS 6,3-A	63	189	30	0.8	1	3	6	1.0	4000	0.5	1.0	1.0	
MMS 10	100	300	50	1.5	2	4.5	10	1.0	7100	0.6	1.0	1.2	
MMS 16	160	480	80	2	3	7.5	15	1.0	6300	0.6	1.0	1.3	
MMS 25	250	750	130	3.5	5	11	23	1.0	5700	0.7	1.0	1.4	
MMS 40	400	1200	210	5	7.5	18	37	1.0	5100	0.7	1.2	1.5	
MMS 63	630	1890	330	7	10	25	60	1.0	4500	0.8	1.2	1.6	
MMS 100	1250	3000	530	15	25	55	120	1.0	3900	0.9	1.2	1.7	
MMS 160	2000	4800	840	25	35	90	190	1.0	3400	1.0	1.5	1.8	
MMS 250	3000	7500	1300	35	55	130	280	1.0	3000	1.2	1.5	2.0	
MMS 400	5000	12000	2100	50	70	200	500	1.0	2700	1.4	1.5	2.2	
MMS 630	7500	18900	3300	120	170	380	700	1.0	2300	1.5	1.5	2.4	
MMS 1000	12500	30000	5000	230	280	600	1100	1.0	2000	1.6	2.0	2.6	
MMS 1600	20000	48000	8400	290	410	950	1900	1.0	1760	1.8	2.0	2.8	
MMS 2500	30000	75000	12000	460	600	1400	2800	1.0	1900	1.8	2.0	2.8	
MMG 4000	40000	120000	12000	400	850	1200	2100	1.0	1370	2.0	2.5	2.5	
MMG 6300	63000	189000	19000	600	1400	1900	3300	1.0	1200	2.5	3.0	3.0	
MMG 10000	100000	300000	30000	950	2200	3100	5300	1.0	1050	2.5	3.5	3.5	
MMG 16000	160000	480000	48000	2300	3000	7500	15000	1.0	910	2.0	4.0	4.0	
MMG 25000	250000	750000	75000	4500	5000	12000	25000	1.0	806	2.5	5.0	4.5	
MMG 40000	400000	1200000	120000	5500	8000	18000	38000	1.0	650	2.5	6.0	5.0	
MMG 63000	630000	1890000	200000	on request				1.0	580	3.0	7.0	5.0	
MMG 100000	1000000	3000000	300000	on request				1.0	520	3.0	8.0	5.0	
MMD 4000	40000	75000	12500	600	850	1900	3800	1.0	2300	2.0	2.5	3.0	
MMD 6300	63000	120000	20000	900	1000	1300	1600	1.0	2000	2.0	2.5	3.2	
MMD 10000	100000	189000	31500	1400	1640	2120	2560	1.0	1800	2.0	2.5	3.5	

*) max. speeds refer to standard couplings made of grey cast iron; higher rotational speeds can be obtained with other materials

Shaft displacements

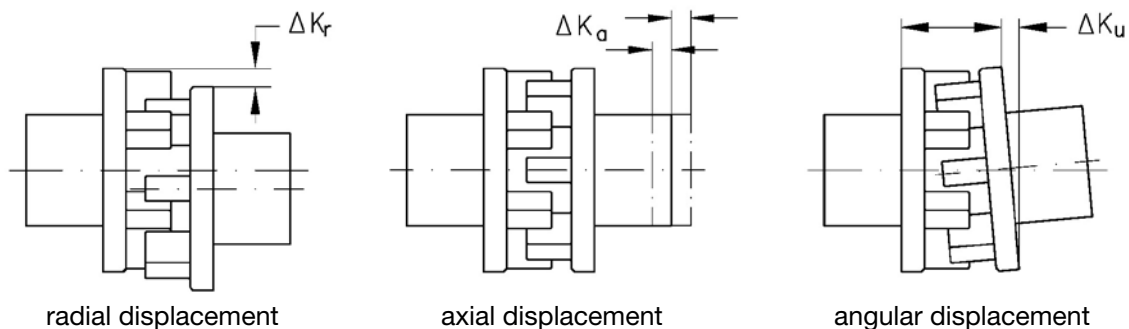

The above shaft displacements are approximate values as the compensating capability of the coupling primarily depends on the rotational speed and coupling load. Precise alignment of the coupling contributes to a long service life of the flexible elements (see “Alignment tolerances“ on page 24).

Permissible rotational speeds

The maximum speeds specified in “Technical data“ only refer to the actual coupling components.

For brake drum and brake disc combined couplings the following n_{max} speeds in rpm are permissible:

Diameter BT/BS	[mm]	200	250	315	400	500	630	710	800	1000	Material
Brake drum BT	n_{max} [rpm]	5250	4200	3300	2600	2100	1650	1450	-	-	0.7050/0.7060 (GGG50/60)
Brake disc BS	n_{max} [rpm]	7000	6000	4800	3800	3000	2400	2150	1900	1500	1.0570 (St 52-3) / 1.0503 (C45)

Materials

Standard coupling hubs of grey cast iron are used unless specified otherwise. Other materials are available as an option.

Part No.	Specification of the coupling components		Material of group A	Material of group C
1, 1g 1a 1	Hub	MMS; MMS-A; MMG MMS TBS and MMS...TBT MMD	0.6025 (GG 25) ¹⁾ 0.7040 (GGG 40) ¹⁾ 0.7040 (GGG 40)	0.7040 (GGG 40) ¹⁾ 0.7040 (GGG 40) ¹⁾ 0.7040 (GGG 40)
2	Retaining cap	Size MMS 10 - 16 Size MMS 25 - 40 Size MMS 63 - 400 Size MMS 630 - 2 500 Size MMG 4 000 - 100 000	polyamide sheet steel sheet steel opt. 0.7040 (GGG 40) 0.7040 (GGG 40) / 1.0570 (St 52-3) 1.0570 (St 52-3)	polyamide sheet steel sheet steel opt. 0.7040 (GGG 40) 0.7040 (GGG 40) / 1.0570 (St 52-3) 1.0570 (St 52-3)
3	Flexible coupling element		see table below	
4	Flange	F1 for MMS and MMG F1 for MMS...TBS and MMS...TBT F1 for MMD	0.7040 (GGG 40) 0.7040 (GGG 40) 0.7040 (GGG 40)	0.7040 (GGG 40) 0.7040 (GGG 40) 0.7040 (GGG 40)
6 6a	Seperable flange hub	MMS MMD MMS...TBS and MMS...TBT	1.0503 (C 45) 0.7040 (GGG 40) / 1.0503 (C 45) 1.0570 (St 52-3) / 1.0503 (C 45)	1.0570 (St 52-3) / 1.0503 (C 45) 0.7040 (GGG 40) / 1.0503 (C 45) 1.0570 (St 52-3) / 1.0503 (C 45)
10	Brake disc		1.0570 (St 52-3) / 1.0503 (C 45)	
11	Brake drum up to Ø 315 mm for F1 BT Brake drum up to Ø 315 mm for WBT Brake drum from Ø 315 mm for WBT and TBT		0.7050 (GGG 50) 1.0570 (St 52-3) / 1.0503 (C 45) 0.7050 (GGG 50)	0.7050 (GGG 50) 1.0570 (St 52-3) / 1.0503 (C 45) 0.7050 (GGG 50)

Other materials on request ¹⁾ Hub also available in steel

Flexible coupling elements

Type of element	Size		Quantity per coupling
MMS toothed ring	MMS-A	4 - 6,3	1
	MMS	10 - 63	
MMS saddle elements	MMS	100 - 2 500	6
MMD rubber elements	MMD	4 000 - 10 000	40
MMG saddle elements	MMG	4 000 - 40 000	6

Material designation	Code	Permissible temperature range		Feature
		shortly		
for standard versions: natural/synthetic rubber mixture hardness range: 75 – 80° Shore A	SN	- 40 °C to 80 °C	90 °C	excellent abrasion resistance
nitrile rubber (NBR) hardness range: 73 – 78° Shore A	SP	- 40 °C to 100 °C	120 °C	mineral oil resistance and motor fuel resistance
silicone (VMQ) hardness range: 70 – 75° Shore A	SX	- 70 °C to 120 °C	140 °C	high temperature resistance
polyurethane (PUR) hardness range: 90 – 95° Shore A	UD	- 30 °C to 120 °C	130 °C	high strength excellent abrasion resistance

Technical details of the MULTI MONT couplings with elements made of NBR, VMQ and PUR on request. Other rubber materials and other shore hardnesses can also be supplied on request.

Balancing

All MULTI MONT couplings are of balancing quality G =16 for n =1500 rpm acc. to ISO 1940 as a standard which is sufficient for normal speed ranges. If a superior balancing quality is required, the coupling components can also be dynamically balanced. In such a case please advise the rotational speed and whether the hubs shall be balanced with or without keyway when placing your order.

Selection of the proper coupling size

The coupling size should be adequately dimensioned to ensure that the permissible coupling load is not exceeded in any operating condition encountered. For drives which are not subjected to periodically recurring vibratory torque loads, the coupling design may be selected based on the driving torque with reference to the corresponding service factors.

For drives with combustion engines or prime movers which are subject to periodically recurring vibratory torques, the final selection of the coupling should be verified by a full torsional vibration analysis which will be conducted by us on request.

1. Calculate the driving torque T_{AN}
Given a driving power P_{AN} and a coupling speed n_{AN} , the driving torque is calculated as follows
2. The nominal torque capacity T_{KN} of the coupling shall be at least equal to the max. drive torque T_{AN} while taking the service factors into account
3. The maximum torque capacity T_{Kmax} of the coupling shall be at least equal to the highest torque T_{max} encountered in operation while taking the temperature factor S_t into account
4. The torsional vibration analysis to verify the coupling selection should confirm that the permissible continuous vibratory torque under reversing stresses T_{KW} is at least equal to the highest vibratory torque under reversing stresses T_W encountered throughout the operating speed range while taking into account the temperature and frequency
5. The frequency factor S_f allows for the frequency dependence of the permissible continuous vibratory torque under reversing stresses $T_{KW (10 Hz)}$ when operating with a different frequency f_x

$$T_{AN} [Nm] = 9550 \frac{P_{AN} [kW]}{n_{AN} [rpm]}$$

$$T_{KN} \geq T_{AN} \cdot S_m \cdot S_t \cdot S_z$$

$$T_{Kmax} \geq T_{max} \cdot S_t$$

$$T_{KW (10 Hz)} \geq T_W \cdot S_t \cdot S_f$$

$$S_f = \sqrt{\frac{f_x}{10}}$$

Service factors

For couplings with silicon elements SX please take account of the load factors for heavy load S.

Load factor S_m

Prime mover	Load factor of the driven machine		
	U	M	H
Electric motors, turbines, hydraulics motors	1.25	1.6	2.0
Combustion engine \geq 4-cylinder Cyclic irregularity \geq 1:100	1.5	2.0	2.5

U = uniform load M = medium load H = heavy load

Temperature factor S_t

Ambient temperature	-40 °C +30 °C	+40 °C	+60 °C	+80 °C	> +80 °C
S_t	1.0	1.1	1.4	1.8	on request

Start-up factor S_z

Starts per hour	30	60	120	240	> 240
S_z	1.0	1.1	1.2	1.3	on request

Calculation example

A coupling is required between an electric motor (P = 450 kW at n = 980 rpm) and a gearbox of a belt conveyor drive.

$$T_{AN} = 9550 \frac{450 \text{ kW}}{980 \text{ rpm}} = 4385,2 \text{ Nm}$$

$$T_{KN} \geq T_{AN} \cdot S_m \cdot S_t \cdot S_z$$

$$T_{KN} \geq 4385,2 \text{ Nm} \cdot 1,25 \cdot 1,1 \cdot 1,0 = 6029,7 \text{ Nm}$$

Selected coupling: MMS 630 SN W at $T_{KN} = 6300 \text{ Nm}$

Uniform load = U : $S_m = 1.25$
Ambient temperature 40 °C : $S_t = 1.1$
Starting frequency 30/h : $S_z = 1.0$

Assignment of the load classification factors to the type of driven machine

U = uniform load	M =medium shock load	H =heavy shock load
------------------	----------------------	---------------------

For drives with periodic excitation of the plant, the coupling selection shall be verified by means of a full torsional vibration analysis.

- BLOWERS, FANS¹⁾**
- U Blowers (axial/centrif.) P:n ≤ 0.007
 - M Blowers (axial/centrif.) P:n ≤ 0.07
 - H Blowers (axial/centrif.) P:n > 0.07
 - U Cooling tower fans P:n ≤ 0.007
 - M Cooling tower fans P:n ≤ 0.07
 - H Cooling tower fans P:n > 0.07
 - U Induced draught fans P:n ≤ 0.007
 - M Induced draught fans P:n ≤ 0.07
 - H Induced draught fans P:n > 0.07
 - U Lobe blowers P:n ≤ 0.007
 - M Lobe blowers P:n ≤ 0.07
 - H Lobe blowers P:n > 0.07
 - U Turbo blowers P:n ≤ 0.007
 - M Turbo blowers P:n ≤ 0.07
 - H Turbo blowers P:n > 0.07

¹⁾ P = power of the driven machine in kW
n = rotational speed in rpm

BUILDING MACHINERY

- H Concrete mixers
- M Hoists
- M Road construction machinery

CHEMICAL INDUSTRY

- U Agitators (light liquids)
- M Agitators (viscous liquids)
- M Centrifuges (heavy)
- U Centrifuges (light-weight)
- M Cooling drums
- M Drying drums
- M Mixers

COMPRESSORS

- M Centrifugal compressors
- H Reciprocating compressors

CONVEYORS

- M Apron conveyors
- M Ballast elevators
- M Belt bucket conveyors
- U Belt conveyors (bulk material)
- H Belt conveyors (piece goods)
- M Chain conveyors
- M Circular conveyors
- U Flour bucket conveyors
- M Goods lifts
- M Hauling winches
- H Hoists
- H Inclined hoists
- M Link conveyors
- M Passenger lifts
- M Screw conveyors
- M Steel belt conveyors
- M Troughed chain conveyors

CRANES

- M Derricking jib gears
- H Hoisting gears
- H Luffing gears
- M Slewing gears
- H Travelling gears

DREDGES

- H Bucket conveyors
- H Bucket wheels
- H Cutter heads
- M Manoeuvring winches
- M Slewing gears
- M Suction pumps
- H Travelling gears (caterpillar)
- M Travelling gears (rails)

FOOD INDUSTRY MACHINERY

- M Cane crushers
- M Cane knives
- H Cane mills
- U Filling machines
- M Kneading machines
- M Mashing apparatus, crystallizers
- U Packaging machines
- M Sugar beet cutters
- M Sugar beet washing machines

GENERATORS, TRANSFORMERS

- H Frequency transformers
- H Generators
- H Welding generators

LAUNDRIES

- M Tumblers
- M Washing machines

METAL ROLLING MILLS

- H Billet shears
- M Chain transfers
- H Cold rolling mills
- H Continuous casting plants
- M Cooling beds
- H Cropping shears
- M Cross transfers
- H Descaling machines
- H Heavy and medium plate mills
- H Ingot handling machinery
- H Ingot pushers
- H Manipulators
- H Plate shears
- M Plate tilters
- M Roller adjustment drives
- M Roller straighteners
- H Roller tables (heavy)
- M Roller tables (light)
- H Sheet mills
- M Trimming shears
- H Tube welding machines
- M Winding machines (strip and wire)
- M Wire drawing benches

METAL WORKING MACHINES

- U Countershafts, line shafts
- H Forging presses
- H Hammers
- U Machine tools, auxiliary drives
- M Machine tools, main drives
- H Metal planing machines
- H Plate straightening machines
- H Presses
- H Punch presses
- H Shears
- M Sheet metal bending machines

OIL INDUSTRY

- M Pipeline pumps
- H Rotary drilling equipment

PAPER MACHINES

- H Calenders
- H Couches
- H Drying cylinders
- H Glazing cylinders
- H Pulpers
- H Pulp grinders
- H Suction rolls
- H Suction presses
- H Wet presses
- H Willows

PLASTIC INDUSTRY MACHINERY

- H Calenders
- H Crushers
- H Extruders
- M Mixers

PUMPS

- U Centrifugal pumps (light liquids)
- M Centrifugal pumps (viscous liquids)
- H Plunger pumps
- H Pressure pumps
- H Reciprocating pumps

RUBBER MACHINERY

- H Calenders
- H Extruders
- M Mixers
- H Pug mills
- H Rolling mills

STONE AND CLAY WORKING MACHINES

- H Ball mills
- H Beater mills
- H Breakers
- H Brick presses
- H Hammer mills
- H Rotary kilns
- H Tube mills

TEXTILE MACHINES

- M Batchers
- M Looms
- M Printing and dyeing machines
- M Tanning vats
- M Willows

WATER TREATMENT

- M Aerators
- H Screw pumps

WOOD WORKING MACHINES

- H Barkers
- M Planing machines
- H Saw frames
- U Wood working machines

Assignment to IEC standard motors

MULTI MONT SELLA coupling series MMS..W for IEC 3-phase motors with squirrel cage rotor acc. to DIN 42673/1

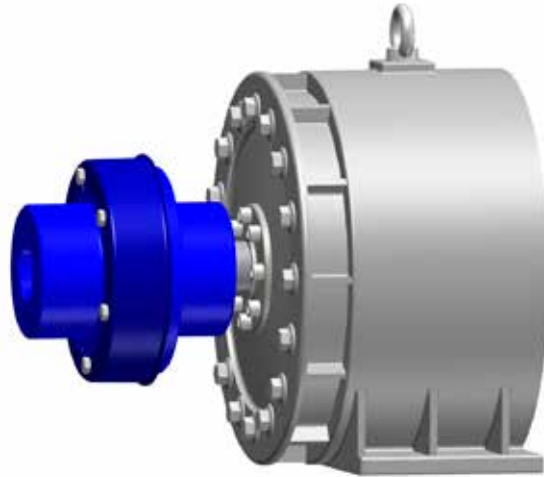

Motor size	Motor power at ~3000 rpm		Coupling size MMS	Motor power at ~1500 rpm		Coupling size MMS	Motor power at ~1000 rpm		Coupling size MMS	Motor power at ~750 rpm		Coupling size MMS	Cyl. shaft extension D x L [mm]		
	power P [kW]	torque T [Nm]		power P [kW]	torque T [Nm]		power P [kW]	torque T [Nm]		power P [kW]	torque T [Nm]		3000 rpm	≤ 1500 rpm	
56	0.09 0.12	0.29 0.38	*) *)	0.06 0.09	0.38 0.57	*) *)								9 x 20	
63	0.18 0.25	0.57 0.80	*) *)	0.12 0.18	0.76 1.1	*) *)								11 x 23	
71	0.37 0.55	1.2 1.8	*) *)	0.25 0.37	1.6 2.4	*) *)								14 x 30	
80	0.75 1.1	2.4 3.5	4 4	0.55 0.75	3.5 4.8	4 4	0.37 0.55	3.5 5.3	4 4					19 x 40	
90 S	1.5	4.8	4	1.1	7.0	4	0.75	7.2	4					24 x 50	
90 L	2.2	7.0	4	1.5	9.6	4	1.1	11	4					24 x 50	
100 L	3	9.6	4	2.2 3	14 19	4 4	1.5	14	4	0.75 1.1	10 14	4 4		28 x 60	
112 M	4	13	4	4	25	4	2.2	21	4	1.5	19	4		28 x 60	
132 S	5.5 7.5	18 24	6.3 6.3	5.5	35	6.3	3	29	6.3	2.2	28	6,3		38 x 80	
132 M	-	-	-	7.5	48	10	4 5.5	38 53	6.3 10	3	38	6,3		38 x 80	
160 M	11 15	35 48	10 10	11	70	10	7.5	72	10	4 5.5	51 70	10 10		42 x 110	
160 L	18.5	59	10	15	96	16	11	105	25	7.5	96	16		42 x 110	
180 M	22	70	16	18.5	118	25	-	-	-	-	-	-		48 x 110	
180 L	-	-	-	22	140	25	15	143	25	11	140	25		48 x 110	
200L	30 37	96 118	25 25	30	191	40	18.5 22	177 210	40 40	15	191	40		55 x 110	
225 S	-	-	-	37	236	40	-	-	-	18.5	236	40		55 x 110	
225 M	45	143	25	45	287	40	30	287	40	22	280	40	55 x 110	60 x 140	
250 M	55	175	40	55	350	63	37	353	63	30	382	63	60 x 140	65 x 140	
280 S	75	239	40	75	478	100	45	430	100	37	471	100	65 x 140	75 x 140	
280 M	90	287	40	90	573	100	55	525	100	45	573	100	65 x 140	75 x 140	
315 S	110	350	63	110	700	100	75	716	100	55	700	100		80 x 170	
315 M	132	420	63	132	840	100	90	860	100	75	955	160	65 x 140	80 x 170	
315 L	160 200	509 637	100 100	160 200	1019 1273	160 160	110 132	1051 1261	160 160	90 110	1146 1401	160 250	65 x 140	80 x 170	
355 L	250 315	796 1003	160 160	250 315	1592 2006	250 250	160 200 250	1528 1910 2388	250 250 400	132 160 200	1681 2037 2547	250 250 400	75 x 140	95 x 170	
400L	355 400	1130 1273	160 160	355 400	2260 2547	400 400	315	3008	400	250	3183	400	80 x 170	100 x 200	

*) For this power range ask for catalogue "MULTI MONT ASTRA"

The assignment takes the maximum hub bore of the couplings into account and provides adequate safety for normal load applications at a load classification factor $S_m = 1.25$. For other loads the design needs to be calculated according to "Selection of the proper coupling size" (see pages 8 and 9).

MULTI MONT SELLA – with taper bush

Series MMS-T...W

The MULTI MONT SELLA claw coupling of type MMS-T... is equipped with a taper bush as a connection element for the shaft. The taper bush is bolted in place in the coupling hub so that a shrink-fit-like connection free from backlash is established between the coupling hub and the shaft after assembly.

Due to the use of commercially available taper bushes with a number of different bore dimensions, the need for finishing the bore and keyway of the coupling hub is omitted for the MULTI MONT SELLA coupling type MMS-T. Assembly and disassembly are possible with no need for special tools!

The maximum torque depends on the respective taper bush.

Furthermore the maximum torque is limited to two times of nominal torque.

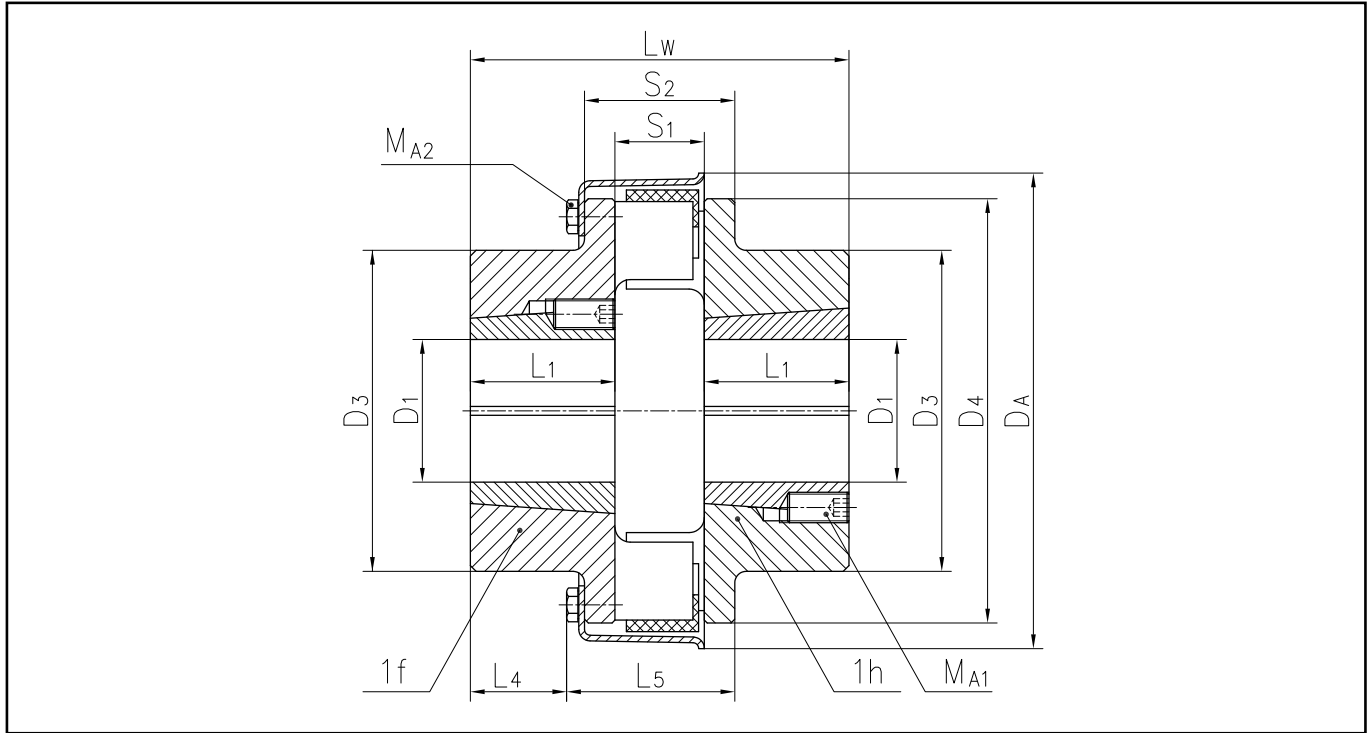

Coupling size	DA mm	TB No.	D1 max mm	D3 mm	D4 mm	L1 mm	L4 mm	L5 mm	Lw mm	S1 mm	S2 mm	m kg	J kgm ²	MA1 Nm	MA2 Nm
MMS-T 25	135	1610	40	85	120	25*	6	49	72	22	38	3.04	0.0061	20	10
MMS-T 40	155	2012	48	102	135	32*	15	52	90	26	44	4.86	0.0120	31	10
MMS-T 63	174	2517	60	123	152	45	27	58	120	30	50	8.36	0.0260	49	10
MMS-T 100	195	3030	75	145	173	76	51	75	187	35	65	16.92	0.0674	92	25
MMS-T 160	221	3030	75	150	198	76	54.2	76.8	193	41	69	20.83	0.1007	92	25
MMS-T 250	250	3535	90	180	223	89	63.6	88.4	225	47	79	33.10	0.2127	115	49
MMS-T 400	282	4040	100	210	251	102	75.6	99.4	260	56	90	51.36	0.4222	172	49
MMS-T 630	330	4040	100	215	294	102	65.5	119.5	268	64	102	69.53	0.8030	172	86
MMS-T 1000	378	4545	110	240	338	115	65.5	136.5	285	75	119	98.10	1.4774	195	86

Available taper bushes

No.	Metric bores with keyway acc. to DIN 6885/1																		
1610	12	14	15	16	18	19	20	22	24	25	28	30	32	35	38	40			
2012	14	16	17	19	20	22	24	25	28	30	32	35	38	40	42	45	48		
2517	16	18	19	20	22	24	25	28	30	32	35	38	40	42	45	48	50	55	60
3030	25	28	30	32	35	38	40	42	45	48	50	55	60	65	70	75			
3535	35	38	40	42	45	48	50	55	60	65	70	75	80	85	90				
4040	40	42	45	48	50	55	60	65	70	75	80	85	90	95	100				
4545	55	60	65	70	75	80	85	90	95	100	105	110							

* The slidback retaining cap protrudes the hub by max. 7mm in case of radial dismantling of the elements

MULTI MONT SELLA – shaft couplings

Series MMS ... W

Standard version for connecting two shafts.

The flexible elements can be easily accessed and removed radially with no need for axial movement of the coupled machines after the retaining cap has been released and withdrawn.

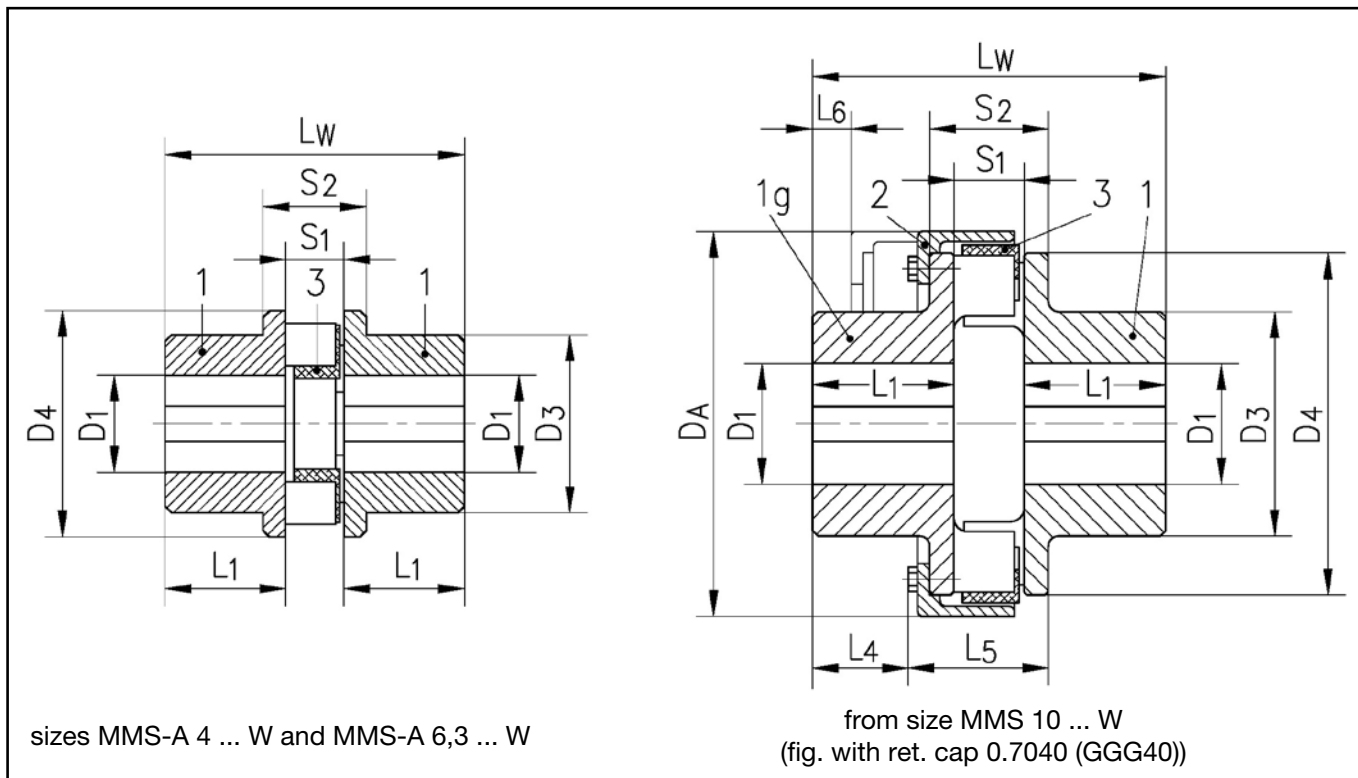

Coupling size	D _A mm	pilot bored	D ₁ [mm] max.		D ₃ mm	D ₄ mm	L ₁ mm	L ₄ mm	L ₅ mm	L ₆ mm	L _W mm	S ₁ mm	S ₂ mm
			0.6025 (GG 25)	0.7040 (GGG 40)									
MMS-A 4	-	unbored, precentered	35	-	55	70	40	-	-	-	98	18	32
MMS-A 6.3	-		40	-	65	82	45	-	-	-	110	20	38
MMS 10	117*		45	-	72	96	48	26	47	19	113	17	33
MMS 16	129*		50	-	78	108	52	29	50	20	123	19	35
MMS 25	135*		55	60	88	120	57	34	53	21	136	22	38
MMS 40	155*		60	65	96	135	61	35	60	21	148	26	44
MMS 63	174* / 175		70	75	110	152	67	40	67	22	164	30	50
MMS 100	195* / 196		75	80	120	173	75	45	77	22	185	35	59
MMS 160	221* / 223		80	85	130	198	82	48	89	21	205	41	69
MMS 250	250* / 252		90	100	145	223	89	51	100	20	225	47	79
MMS 400	282* / 290		100	105	160	251	97	56	114	17	250	56	90
MMS 630	330		56	120	130	200	294	116	80	118	25	296	64
MMS 1000	378	68	140	150	225	338	140 ¹⁾	90	137	25	335	75	119
MMS 1600	432	88	160	170	255	390	160 ¹⁾	104	147	31	373	85	129
MMS 2500	485	-	-	180	275	445	250 ¹⁾	161	173	68	510	110	160

* retaining cap made of sheet steel polyamide; larger values apply to the material 0.7040 (GGG 40)

¹⁾ figure is not in accordance with actual design

MULTI MONT SELLA – flange couplings

Series MMS ... F1

For flange-mounting to discs and flywheels.

The flexible elements can be easily accessed and removed radially with no need for axial movement of the coupled machines after the retaining cap has been released and withdrawn.

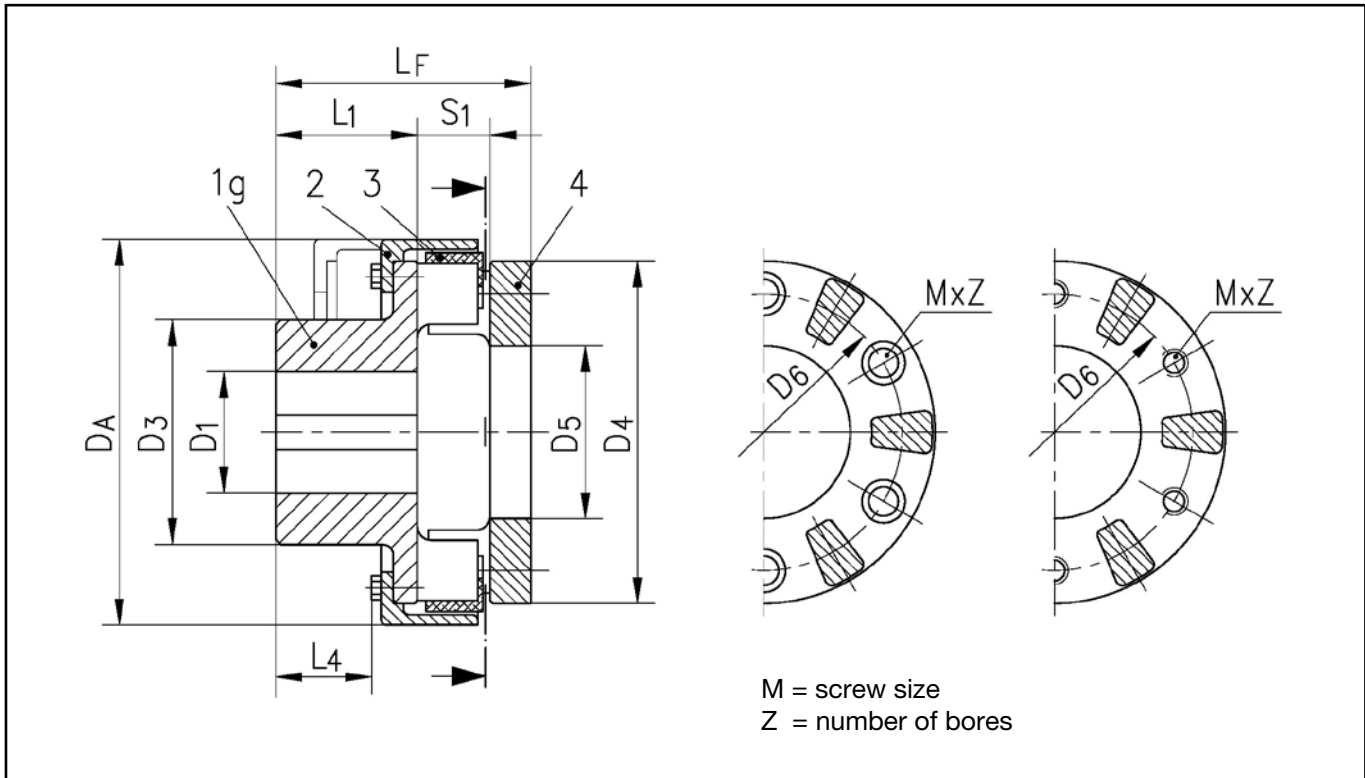

Coupling size	D _A mm	pilot bored	D ₁ [mm] max.		D ₃ mm	D ₄ mm	D ₅ H ₇ mm	D ₆ mm	M	Z	L ₁ mm	L ₄ mm	L _F mm	S ₁ mm
			0.6025 (GG 25)	0.7040 (GGG 40)										
MMS-A 4	-	unbored, precentered	35	-	55	70	35	50	M 6	4	40	-	68	18
MMS-A 6.3	-		40	-	65	82	40	60	M 6	4	45	-	75	20
MMS 10	117*		45	-	72	96	50	80	M 8	6	48	26	78	17
MMS 16	129*		50	-	78	108	58	92	M 8	6	52	29	84	19
MMS 25	135*		55	60	88	120	65	101	M 10	6	57	34	94	22
MMS 40	155*		60	65	96	135	70	114	M 10	6	61	35	102	26
MMS 63	174* / 175		70	75	110	152	78	126	M 12	6	67	40	115	30
MMS 100	195* / 196		75	80	120	173	90	148	M 12	12	75	45	131	35
MMS 160	221* / 223		80	85	130	198	100	162	M 16	6	82	48	147	41
MMS 250	250* / 252		90	100	145	223	115	180	M 16	6	89	51	163	47
MMS 400	282* / 290		100	105	160	251	125	206	M 20	12	97	56	183	56
MMS 630	330	56	120	130	200	294	150	238	M 20	12	116	80	210	64
MMS 1000	378	68	140	150	225	338	175	278	M 20	12	140 ¹⁾	90	235	75
MMS 1600	432	88	160	170	255	390	200	322	M 20	12	160 ¹⁾	104	260	85
MMS 2500	485	-	-	180	275	445	240	360	M 24	12	250 ¹⁾	161	360	110

* retaining cap made of sheet steel/polyamide; larger values apply to the material 0.7040 (GGG 40)

¹⁾ figure is not in accordance with actual design

MULTI MONT SELLA – separable shaft couplings

Series MMS ... T

This version allows radial assembly of the coupled machines with no need for their axial movement.

The separately bolted on retaining cap allows changing the flexible elements with no need for axial movement of either of the coupling hubs.

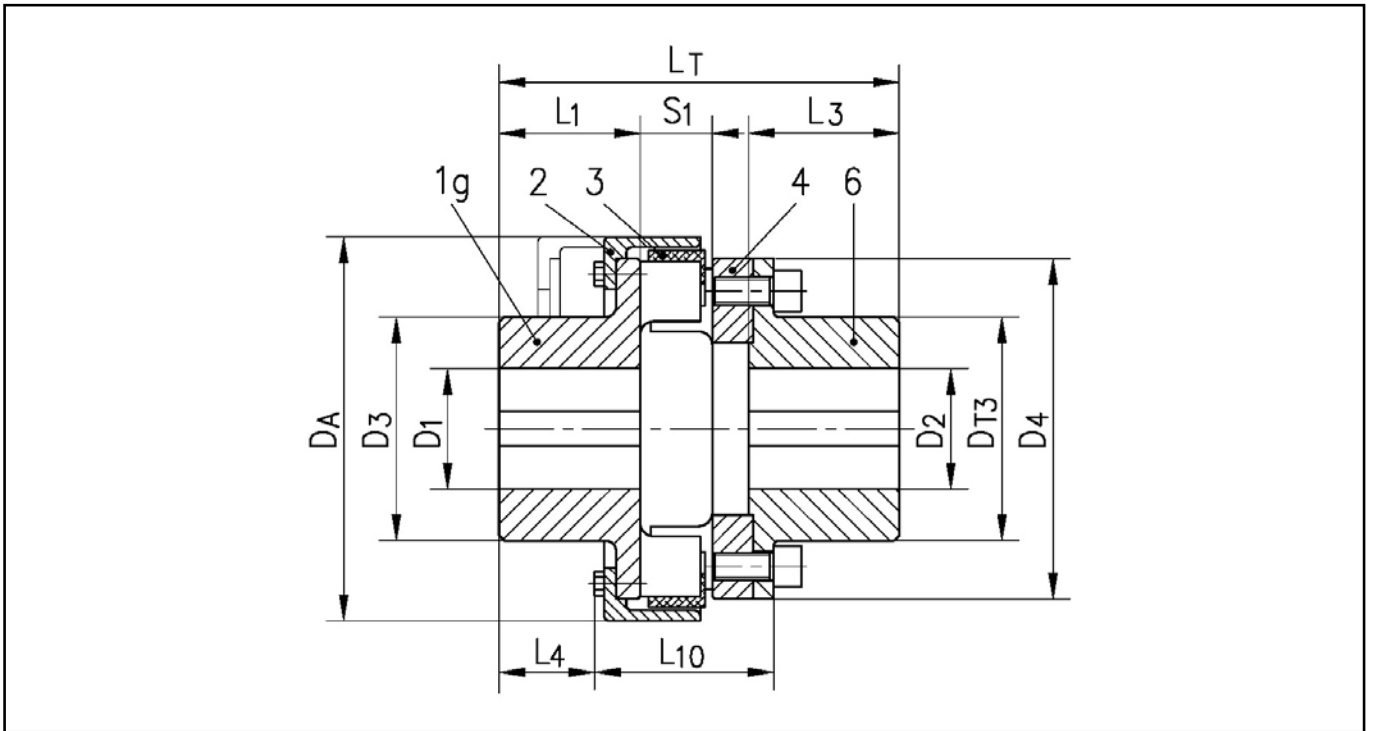

Coupling size	D _A mm	pilot bored	D ₁ D ₂ [mm]		D ₃ mm	D _{T3} mm	D ₄ mm	L ₁ mm	L ₃ mm	L ₄ mm	L ₁₀ mm	L _T mm	S ₁ mm
			max. 0.6025 (GG 25)	0.7040 (GGG 40)									
MMS 10	117*	unbored, precentered	45	-	72	64	96	48	52	26	57	128	17
MMS 16	129*		50	-	78	72	108	52	57	29	63	139	19
MMS 25	135*		55	60	88	78	120	57	62	34	68	154	22
MMS 40	155*		60	65	96	96	135	61	68	35	76	168	26
MMS 63	174* / 175		70	75	110	104	152	67	75	40	85	188	30
MMS 100	195* / 196		75	80	120	118	173	75	82	45	97	211	35
MMS 160	221* / 223		80	85	130	130	198	82	88	48	111	232	41
MMS 250	250* / 252		90	100	145	145	223	89	98	51	124	258	47
MMS 400	282* / 290		100	105	160	160	251	97	105	56	141	285	56
MMS 630	330		56	120	130	200	195	294	116	134	80	145	341
MMS 1000	378	68	140	150	225	225	338	140 ¹⁾	154	90	163	386	75
MMS 1600	432	88	160	170	255	255	390	160 ¹⁾	170	104	177	426	85
MMS 2500	485	-	-	180	275	275	445	250 ¹⁾	250	161	232	606	110

* retaining cap made of sheet steel/polyamide; larger values apply to the material 0.7040 (GGG 40)

¹⁾ figure is not in accordance with actual design

MULTI MONT SELLA – brake disc couplings

Series MMS ... WBS

The flexible elements can be easily fitted and removed radially with no need for axial movement of the coupled machines after the retaining cap has been released and withdrawn.

For higher requirements, like optimized controlled drives, from size MMS 100 on designs with accurate pitch and torsional minimized backlash are available on request.

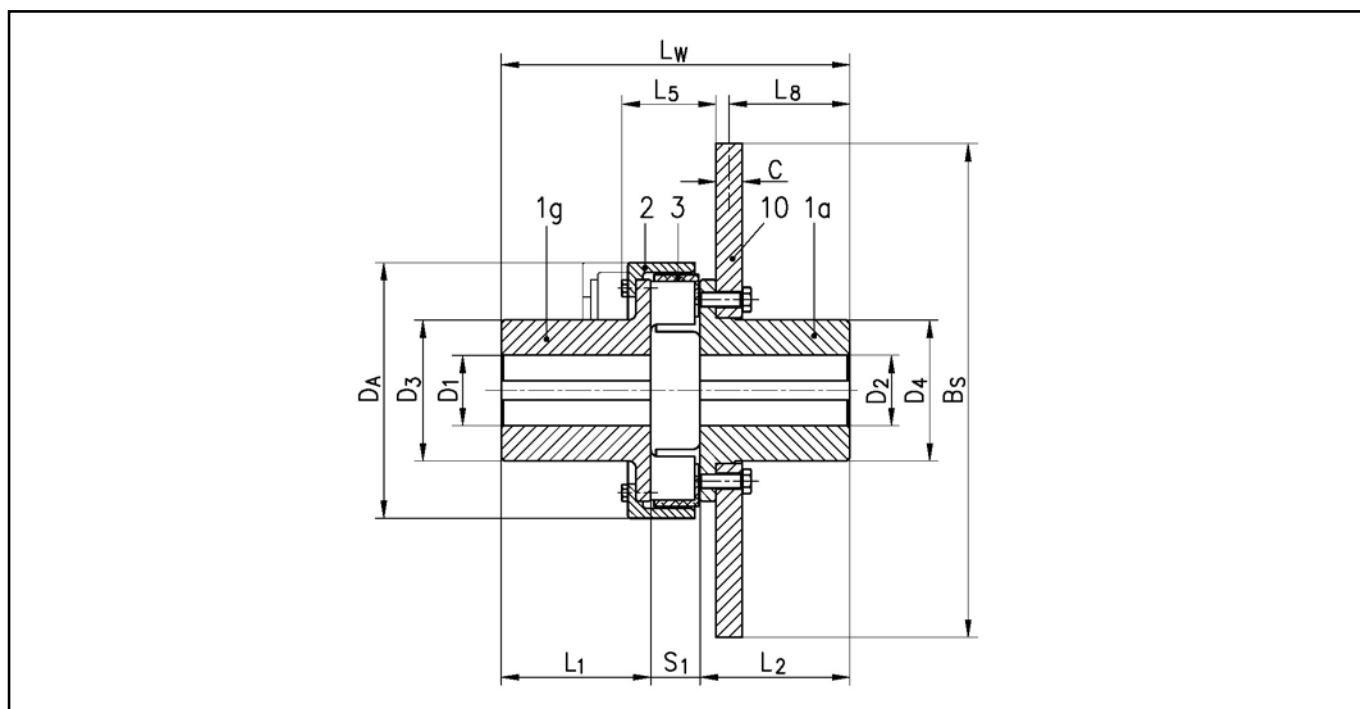

Coupling size	BS	C	DA	D ₁ /D ₂		D ₃	D ₄	L ₁		L ₂	L ₅	L ₈	L _w		S ₁
				pilot mm	max. mm			norm mm	long mm				norm mm	long mm	
MMS 40 WBS 315	30	155	unbored, precentered	65	96	94	61	110	110	60	85.5	197	246	26	
MMS 63 WBS 355	30	175		75	110	110	67	110	110	65	84.5	207	250	30	
MMS 63 WBS 400	30	175		75	110	110	67	110	110	65	84.5	207	250	30	
MMS 100 WBS 450	30	196		80	120	120	75	140	140	79	110.5	250	315	35	
MMS 100 WBS 500	30	196		80	120	120	75	140	140	79	110.5	250	315	35	
MMS 160 WBS 450	30	223		85	130	130	82	140	140	90	110.5	263	321	41	
MMS 160 WBS 500	30	223		85	130	130	82	140	140	90	110.5	263	321	41	
MMS 160 WBS 560	30	223		85	130	130	82	140	140	90	110.5	263	321	41	
MMS 250 WBS 500	30	252		100	145	145	89	170	170	101	138.5	306	387	47	
MMS 250 WBS 560	30	252		100	145	145	89	170	170	101	138.5	306	387	47	
MMS 250 WBS 630	30	252		100	145	145	89	170	170	101	138.5	306	387	47	
MMS 400 WBS 560	30	290		105	160	160	97	170	170	115	136.5	323	396	56	
MMS 400 WBS 630	30	290		105	160	160	97	170	170	115	136.5	323	396	56	
MMS 400 WBS 710	30	290		105	160	160	97	170	170	115	136.0	323	396	56	
MMS 630 WBS 630	30	330		56	130	200	192	116	210	210	121	175.5	390	484	64
MMS 630 WBS 710	30	330	56	130	200	192	116	210	210	121	175.0	390	484	64	
MMS 630 WBS 800	30	330	56	130	200	192	116	210	210	121	175.0	390	484	64	
MMS 1000 WBS 710	30	378	68	150	225	225	140 ¹⁾	210 ¹⁾	210 ¹⁾	139	162.0	405	475	75	
MMS 1000 WBS 800	30	378	68	150	225	225	140 ¹⁾	210 ¹⁾	210 ¹⁾	139	162.0	405	475	75	
MMS 1000 WBS 1000	40	378	68	150	225	225	140 ¹⁾	210 ¹⁾	210 ¹⁾	139	157.0	405	475	75	
MMS 1600 WBS 1000	40	432	88	170	255	252	160 ¹⁾	210 ¹⁾	210 ¹⁾	148	150.0	423	473	85	
MMS 2500 WBS 800	30	485	-	180	275	270	200 ¹⁾	250 ¹⁾	250 ¹⁾	173	160.0	460	510	110	

¹⁾ figure is not in accordance with actual design

MULTI MONT SELLA – brake disc couplings

Series MMS ... TBS

The TBS series allows radial removal of the brake disc with no need for axial movement of the coupling hubs. The flexible elements can also be easily fitted and removed radially with no need for axial movement of the coupled machines after the retaining cap has been released and withdrawn.

For higher requirements, like optimized controlled drives, from size MMS 100 on designs with accurate pitch and torsional minimized backlash are available on request.

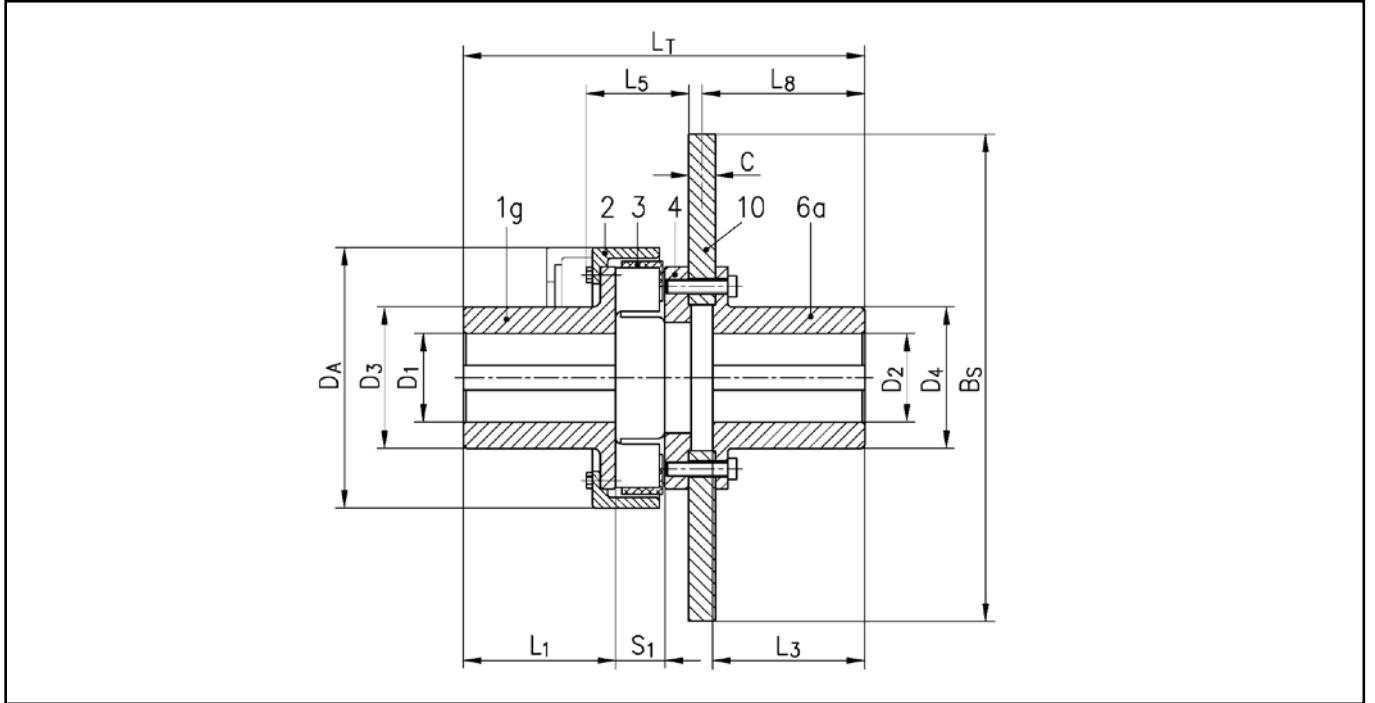

Coupling size	BS	C	D _A	D ₁ /D ₂		D ₃	D ₄	L ₁		L ₃	L ₅	L ₈	L _T		S ₁
				pilot mm	max. mm			norm mm	long mm				norm mm	long mm	
MMS 40	TBS 315	30	155	unbored, precentered	65	94	96	61	110	110	63	123.5	239	288	26
MMS 63	TBS 355	30	175		75	110	110	67	110	110	71	123.5	252	295	30
MMS 63	TBS 400	30	175		75	110	110	67	110	110	71	123.5	252	295	30
MMS 100	TBS 400	30	196		80	120	120	75	140	140	84	153.5	298	363	35
MMS 100	TBS 450	30	196		80	120	120	75	140	140	84	153.5	298	363	35
MMS 100	TBS 500	30	196		80	120	120	75	140	140	84	153.5	298	363	35
MMS 160	TBS 450	30	223		85	130	130	82	140	140	98	153.5	314	372	41
MMS 160	TBS 500	30	223		85	130	130	82	140	140	98	153.5	314	372	41
MMS 160	TBS 560	30	223		85	130	130	82	140	140	98	153.5	314	372	41
MMS 250	TBS 500	30	252		100	145	145	89	170	170	110	182.5	359	440	47
MMS 250	TBS 560	30	252		100	145	145	89	170	170	110	182.5	359	440	47
MMS 250	TBS 630	30	252		100	145	145	89	170	170	110	182.5	359	440	47
MMS 400	TBS 630	30	290		105	160	160	97	170	170	124	182.5	378	451	56
MMS 400	TBS 710	30	290		105	160	160	97	170	170	124	183.0	379	452	56
MMS 630	TBS 630	30	330	56	130	200	195	116	210	210	128	223.0	446	540	64
MMS 630	TBS 710	30	330	56	130	200	195	116	210	210	128	223.0	446	540	64
MMS 630	TBS 800	30	330	56	130	200	195	116	210	210	128	223.0	446	540	64
MMS 1000	TBS 710	30	378	68	150	225	225	140 ¹⁾	210 ¹⁾	210	143	223.0	471	541	75
MMS 1000	TBS 800	30	378	68	150	225	225	140 ¹⁾	210 ¹⁾	210	143	223.0	471	541	75
MMS 1000	TBS 1000	40	378	68	150	225	225	140 ¹⁾	210 ¹⁾	210	143	228.0	481	551	75
MMS 1600	TBS 800	30	432	88	170	255	255	160 ¹⁾	210 ¹⁾	210	153	223.0	495	545	85
MMS 1600	TBS 1000	40	432	88	170	255	255	160 ¹⁾	210 ¹⁾	210	153	228.0	505	555	85
MMS 2500	TBS 800	30	485	-	180	275	300	200 ¹⁾	250 ¹⁾	250	185	262.0	574	624	110

1) figure is not in accordance with actual design

MULTI MONT SELLA – brake drum couplings

Series MMS ... WBT

The flexible elements can be easily fitted and removed radially with no need for axial movement of the coupled machines after the retaining cap has been released and withdrawn. Thanks to the optional mounting facility of the brake drum, the dimension L_7 or L_9 can be obtained between the gear side shaft end and the brake drum.

For higher requirements, like optimized controlled drives, from size MMS 100 on designs with accurate pitch and torsional minimized backlash are available on request.

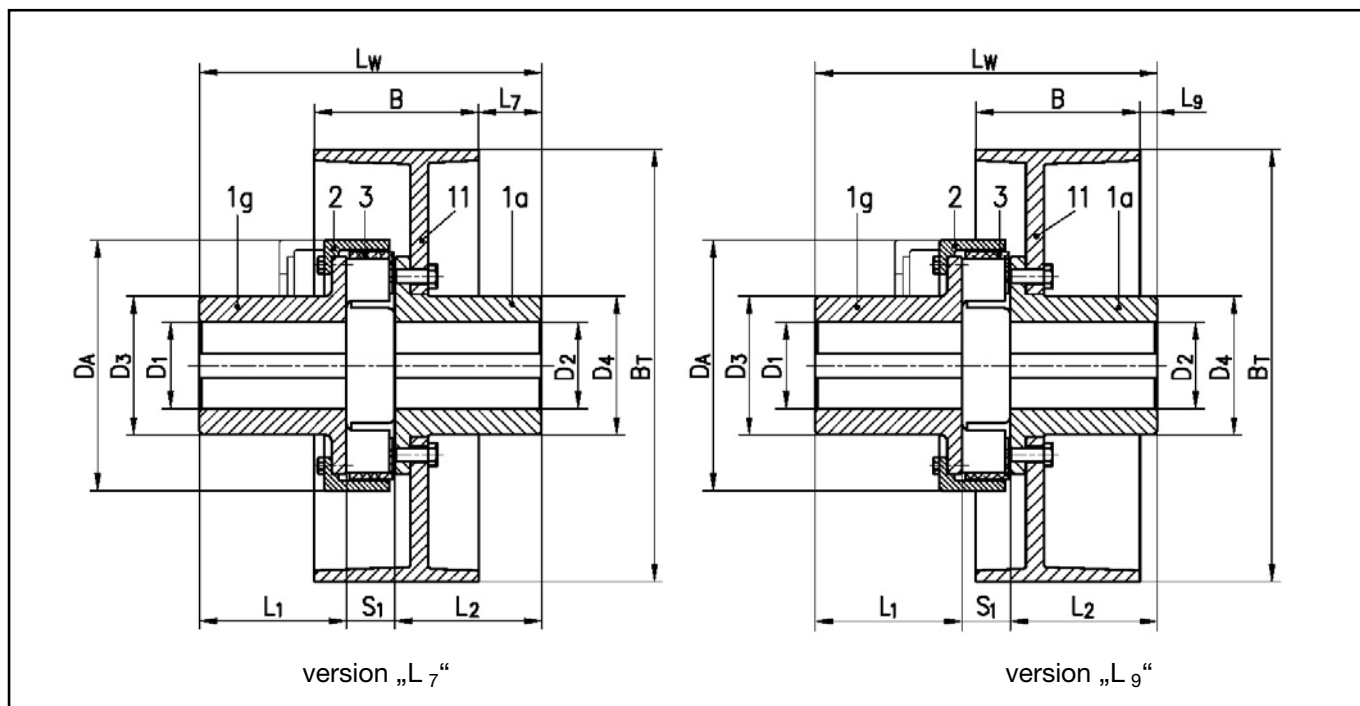

Coupling size	BT	B	D _A	D ₁ /D ₂		D ₃	D ₄	L ₁		L ₂	L ₇	L ₉	L _w		S ₁	
				pilot bored	max. mm			norm mm	long mm				norm mm	long mm		
MMS 25 WBT 200	200	75	135	unbored, precentered	60	88	87	57	110	110	71	40	189	242	22	
MMS 40 WBT 200	200	75	155		65	96	94	61	110	110	71	40	197	246	26	
MMS 40 WBT 250	250	95	155		65	96	94	61	110	110	56	35	197	246	26	
MMS 63 WBT 250	250	95	175		75	110	110	67	110	110	55	34	207	250	30	
MMS 63 WBT 315	315	118	175		75	110	110	67	110	110	61	5	207	250	30	
MMS 100 WBT 315	315	118	196		80	120	120	75	140	140	87	31	250	315	35	
MMS 160 WBT 315	315	118	223		85	130	130	82	140	140	87	31	263	321	41	
MMS 160 WBT 400	400	150	223		85	130	130	82	140	140	70	11	263	321	41	
MMS 250 WBT 400	400	150	252		100	145	145	89	170	170	98	39	306	387	47	
MMS 250 WBT 500	500	190	252		100	145	145	89	170	170	75	22	306	387	47	
MMS 400 WBT 500	500	190	290		105	160	160	97	170	170	73	20	323	396	56	
MMS 400 WBT 630	630	236	290		105	160	160	97	170	170	41	0	323	396	56	
MMS 630 WBT 500	500	190	330		56	130	200	192	116	210	210	112	59	390	484	64
MMS 630 WBT 630	630	236	330		56	130	200	192	116	210	210	80	39	390	484	64
MMS 630 WBT 710	710	265	330	56	130	200	192	116	210	210	70	20	390	484	64	
MMS 1000 WBT 630	630	236	378	68	150	225	225	140 ¹⁾	210 ¹⁾	210 ¹⁾	67	26	405	475	75	
MMS 1000 WBT 710	710	265	378	68	150	225	225	140 ¹⁾	210 ¹⁾	210 ¹⁾	57	7	405	475	75	
MMS 1600 WBT 710	710	265	432	88	170	255	252	160 ¹⁾	210 ¹⁾	210 ¹⁾	50	0	423	473	85	

¹⁾ figure is not in accordance with actual design
MMS 2500 WBT on request

MULTI MONT SELLA – brake drum couplings

Series MMS ... TBT

The flexible elements can be easily fitted and removed radially with no need for axial movement of the coupled machines after the retaining cap has been released and withdrawn. Thanks to the optional mounting facility of the brake drum, the dimension L_7 or L_9 can be obtained between the gear side shaft end and the brake drum.

The brake drum can be disassembled without having to pull off the gear side coupling hub.

For higher requirements, like optimized controlled drives, from size MMS 100 on designs with accurate pitch and torsional minimized backlash are available on request.

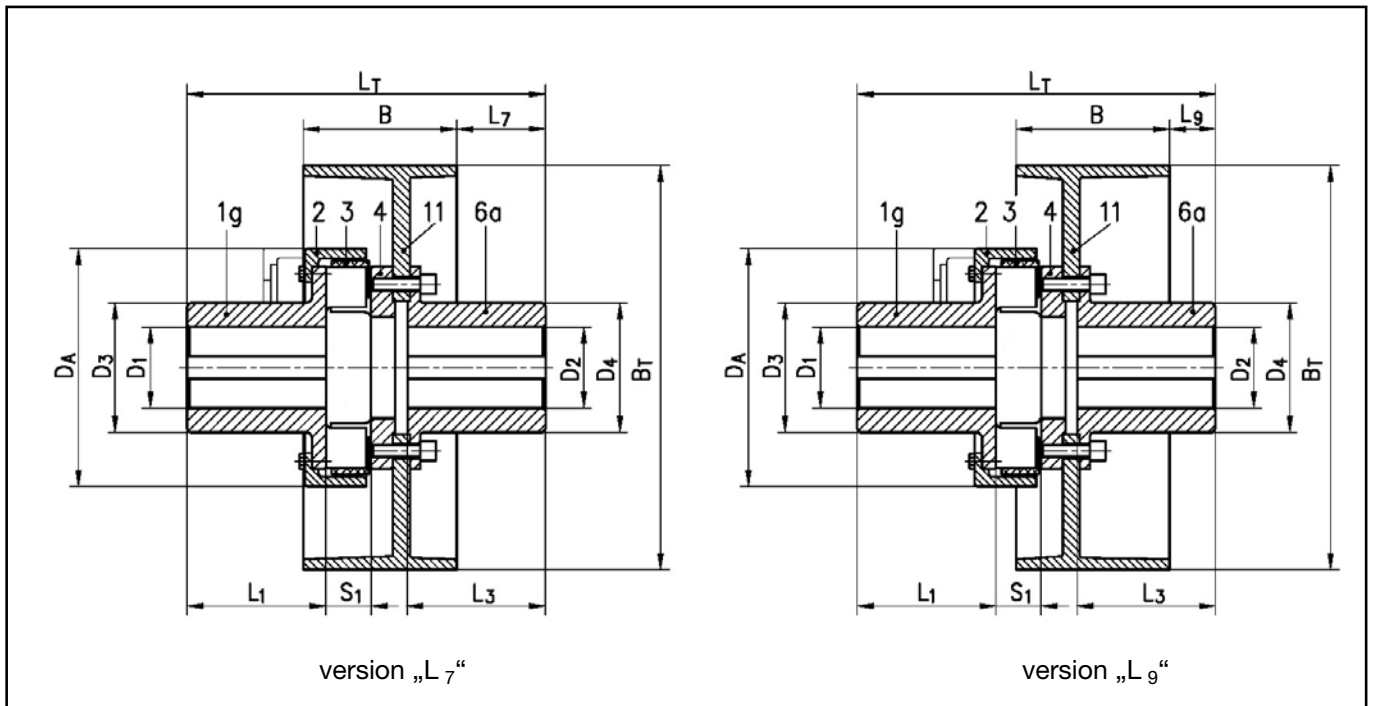

Coupling size	BT	B	D_A	D_1/D_2		D_3	D_4	L_1		L_3	L_7	L_9	L_T		S_1
				pilot bored	max. mm			norm mm	long mm				norm mm	long mm	
MMS 40 TBT 200	75	155	unbored, precentered	65	96	96	61	110	110	94	63	224	273	26	
MMS 40 TBT 250	95	155		65	96	96	61	110	110	79	58	224	273	26	
MMS 63 TBT 250	95	175		75	110	110	67	110	110	79	58	237	280	30	
MMS 63 TBT 315	118	175		75	110	110	67	110	110	85	29	237	280	30	
MMS 100 TBT 315	118	196		80	120	120	75	140	140	115	59	283	348	35	
MMS 160 TBT 315	118	223		85	130	130	82	140	140	115	59	299	357	41	
MMS 160 TBT 400	150	223		85	130	130	82	140	140	103	14	304	362	41	
MMS 250 TBT 400	150	252		100	145	145	89	170	170	132	73	349	430	47	
MMS 250 TBT 500	190	252		100	145	145	89	170	170	109	56	349	430	47	
MMS 400 TBT 500	190	290		105	160	160	97	170	170	109	56	368	441	56	
MMS 400 TBT 630	236	290		105	160	160	97	170	170	83	42	374	447	56	
MMS 630 TBT 500	190	330	56	130	200	195	116	210	210	149	96	436	530	64	
MMS 630 TBT 630	236	330	56	130	200	195	116	210	210	123	82	441	535	64	
MMS 630 TBT 710	265	330	56	130	200	195	116	210	210	113	63	441	535	64	
MMS 1000 TBT 630	236	378	68	150	225	225	140 ¹⁾	210 ¹⁾	210	123	82	466	536	75	
MMS 1000 TBT 710	265	378	68	150	225	225	140 ¹⁾	210 ¹⁾	210	113	63	466	536	75	
MMS 1600 TBT 710	265	432	68	170	255	255	160 ¹⁾	210 ¹⁾	210	113	63	490	540	85	

¹⁾ figure is not in accordance with actual design
MMS 2500 TBT on request

MULTI MONT SELLA – brake drum couplings

Series MMS ... F1 BT

The flexible elements can be easily accessed and removed radially with no need for axial movement of the coupled machines after the retaining cap has been released and withdrawn.

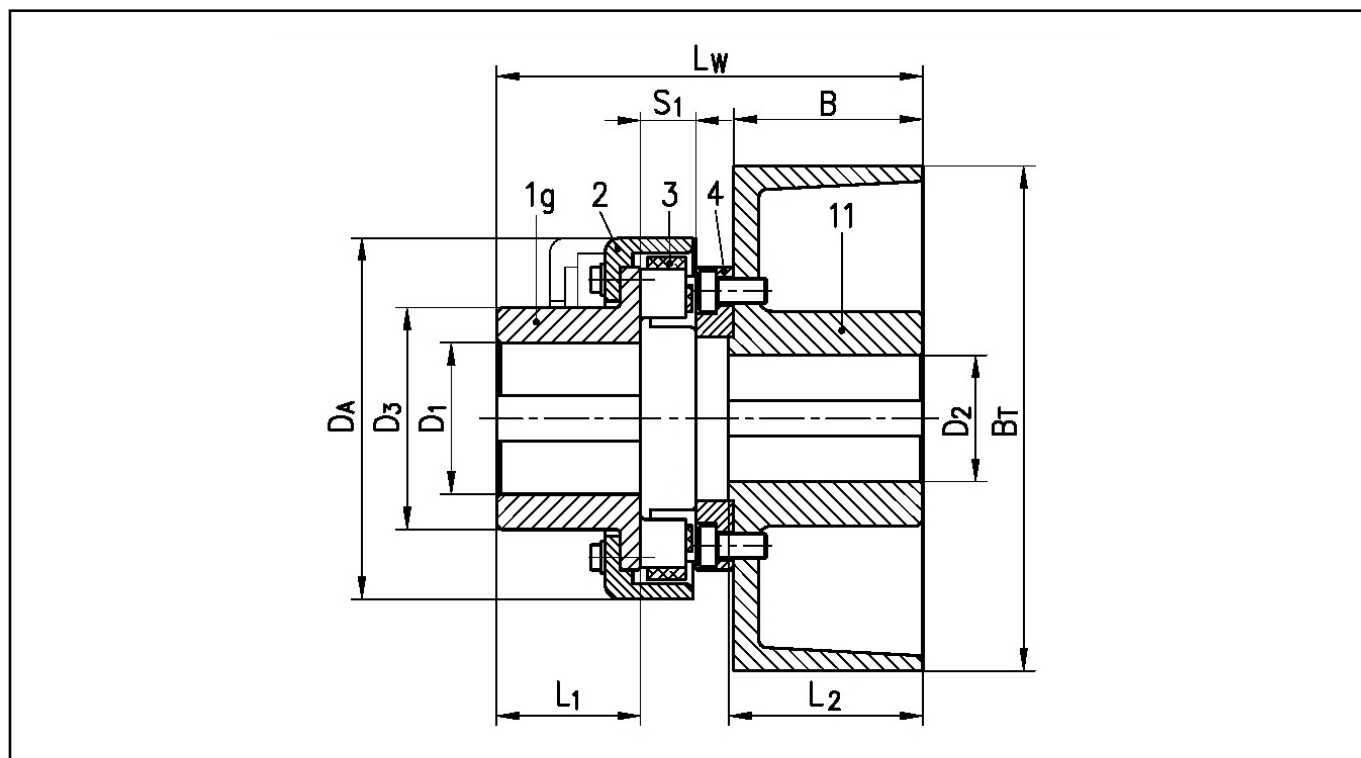

Coupling size	BT	B mm	DA mm	D ₁		D ₂		D ₃ mm	L ₁		L ₂ mm	L _w		S ₁ mm
				pilot bored	max. mm	min. mm	max. mm		norm mm	long mm		norm mm	long mm	
MMS 10	F1 BT 200	75	129	unbored, precentered	60	20	50	78	52	-	77	159	-	19
MMS 16	F1 BT 200	75	134		60	20	50	88	57	110	77	169	222	22
MMS 25	F1 BT 250	95	135		50	25	60	88	57	110	97	189	242	22
MMS 40	F1 BT 200	75	155		65	20	50	96	61	110	77	177	226	26
MMS 63	F1 BT 250	95	155		65	25	60	96	61	110	97	197	246	26
MMS 100	F1 BT 315	118	155		65	30	65	96	61	110	120	220	269	26
MMS 160	F1 BT 250	95	175		75	25	60	110	67	110	97	210	253	30
MMS 250	F1 BT 315	118	175		75	30	70	110	67	110	120	233	276	30
MMS 400	F1 BT 315	118	196		80	30	80	120	75	140	120	249	314	35

Weights and moments of inertia

The specified values apply to hubs with maximum bore diameters.

MULTI MONT SELLA shaft-, flange- and separable shaft couplings

Coupling size	MMS ... W		MMS ... F1		MMS ... T		Hub with ret. cap ¹⁾ parts 1g / 2 / 3		Hub with ret. cap ²⁾ parts 1g / 2 / 3	
	m _{total} kg	J _{total} kgm ²	m _{total} kg	J _{total} kgm ²	m _{total} kg	J _{total} kgm ²	m ₁ kg	J ₁ kgm ²	m ₁ kg	J ₁ kgm ²
MMS-A 4	1.2	0.0006	0.8	0.0005	-	-	-	-	-	-
MMS-A 6.3	1.9	0.0016	1.3	0.0012	-	-	-	-	-	-
MMS 10	2.4	0.0026	1.8	0.002	2.8	0.0028	1.3	0.0014	-	-
MMS 16	3.1	0.0042	2.4	0.004	3.7	0.0055	1.7	0.0023	-	-
MMS 25	4.2	0.007	3.3	0.006	4.9	0.008	2.2	0.004	-	-
MMS 40	5.7	0.011	4.5	0.010	7.1	0.015	3.0	0.006	-	-
MMS 63	8.2	0.023	6.6	0.021	10.0	0.029	4.4	0.013	5.2	0.018
MMS 100	11.7	0.044	9.6	0.041	14.4	0.055	6.2	0.025	7.4	0.035
MMS 160	16.6	0.078	13.9	0.076	20.5	0.102	8.8	0.044	10.7	0.064
MMS 250	23.3	0.140	19.7	0.138	28.9	0.182	12.4	0.079	15.1	0.116
MMS 400	32.5	0.256	28.3	0.257	40.4	0.331	17.5	0.149	22.6	0.242
MMS 630	62.0	0.737	51.3	0.696	73.1	0.876	-	-	36.0	0.484
MMS 1000	90.5	1.413	73.0	1.300	107.0	1.670	-	-	51.9	0.911
MMS 1600	131.0	2.689	107.0	2.487	154.0	3.193	-	-	75.4	1.742
MMS 2500	215.0	5.360	177.0	5.210	274.0	7.080	-	-	122.1	3.407

MULTI MONT SELLA brake disc and brake drum couplings

Coupling size	Hubside parts 1g / 2 / 3				BS Ø	MMS ... WBS parts 1a / 10		MMS ... TBS parts 4/6a / 10		BT Ø	MMS ... WBT parts 1a / 11		MMS ... TBT parts 4/6a / 11		MMS ... F1 BT parts 4a / 11	
	L ₁ normal		L ₁ long			m ₂ kg	J ₂ kgm ²	m ₂ kg	J ₂ kgm ²		m ₂ kg	J ₂ kgm ²	m ₂ kg	J ₂ kgm ²	m ₂ kg	J ₂ kgm ²
	m ₁ kg	J ₁ kgm ²	m ₁ kg	J ₁ kgm ²												
MMS 16 ... ¹⁾	1.7	0.0023			-					200					7.3	0.031
MMS 25 ... ¹⁾	2.2	0.004	3.3	0.006	-					200	9.0	0.048			7.4	0.060
MMS 25 ... ¹⁾	2.2	0.004	3.3	0.006	-					250					12.6	0.121
MMS 40 ... ¹⁾	3.0	0.006	4.0	0.008	-					200	9.5	0.050	10.9	0.054	7.7	0.035
MMS 40 ... ¹⁾	3.0	0.006	4.0	0.008	-					250	14.7	0.135	16.1	0.139	12.9	0.096
MMS 40 ... ¹⁾	3.0	0.006	4.0	0.008	315	20.4	0.232	21.8	0.236	315					26.0	0.315
MMS 63 ... ²⁾	5.2	0.018	6.6	0.021	355	26.2	0.376	27.9	0.382	250	15.9	0.141	17.7	0.147	13.6	0.100
MMS 63 ... ²⁾	5.2	0.018	6.6	0.021	400	32.5	0.601	34.2	0.607	315	25.0	0.387	26.8	0.393	26.8	0.318
MMS 100 ... ²⁾	7.4	0.035	10.3	0.043	400	35.3	0.613	38.4	0.626	315	28.0	0.400	31.1	0.413	27.9	0.326
MMS 100 ... ²⁾	7.4	0.035	10.3	0.043	450	43.1	0.969	46.2	0.982	-						
MMS 100 ... ²⁾	7.4	0.035	10.3	0.043	500	51.9	1.466	55.0	1.479	-						
MMS 160 ... ²⁾	10.7	0.064	13.6	0.073	450	45.0	0.984	49.9	1.013	315	30.0	0.415	34.9	0.444		
MMS 160 ... ²⁾	10.7	0.064	13.6	0.073	500	53.8	1.481	58.7	1.510	400	39.3	0.868	44.4	0.897		
MMS 160 ... ²⁾	10.7	0.064	13.6	0.073	560	65.5	2.309	70.4	2.338	-						
MMS 250 ... ²⁾	15.1	0.116	19.4	0.135	500	57.5	1.515	64.3	1.566	400	43.5	0.902	50.3	0.953		
MMS 250 ... ²⁾	15.1	0.116	19.4	0.135	560	69.3	2.343	76.1	2.394	500	64.0	2.354	70.8	2.405		
MMS 250 ... ²⁾	15.1	0.116	19.4	0.135	630	84.7	3.711	91.5	3.762	-						
MMS 400 ... ²⁾	22.6	0.242	28.8	0.274	560	74.3	2.396	83.6	2.485	500	69.3	2.409	78.6	2.498		
MMS 400 ... ²⁾	22.6	0.242	28.8	0.274	630	89.7	3.764	99.0	3.853	630	112.8	6.704	122.1	6.884		
MMS 400 ... ²⁾	22.6	0.242	28.8	0.274	710	109.8	5.999	119.1	6.088	-						
MMS 630 ... ²⁾	36.0	0.484	44.8	0.549	630	101.4	3.929	115.2	4.102	500	81.6	2.578	95.4	2.751		
MMS 630 ... ²⁾	36.0	0.484	44.8	0.549	710	121.5	6.166	135.3	6.339	630	124.8	6.869	138.6	7.042		
MMS 630 ... ²⁾	36.0	0.484	44.8	0.549	800	146.6	9.759	160.4	9.932	710	160.7	12.018	174.5	12.191		
MMS 1000 ... ²⁾	51.9	0.911	61.8	1.014	710	132.6	6.428	149.4	6.705	630	136.1	7.130	152.9	7.407		
MMS 1000 ... ²⁾	51.9	0.911	61.8	1.014	800	157.7	10.021	174.5	10.298	710	172.1	12.285	188.9	12.562		
MMS 1000 ... ²⁾	51.9	0.911	61.8	1.014	1000	282.7	31.345	299.5	31.622	-						
MMS 1600 ... ²⁾	75.4	1.742	82.7	1.851	800	170.2	10.452	196.6	10.982	710	184.6	12.706	211.0	13.236		
MMS 1600 ... ²⁾	75.4	1.742	82.7	1.851	1000	294.4	31.766	320.8	32.296	-						

¹⁾ Version with retaining cap made of sheet steel /polyamide ²⁾ Version with ret. cap made of 7.7040 (GGG40)/1.0570 (St 52-3)

Values for MMS 2500 on request

MULTI MONT DEKA standard types

Designed as shaft couplings, flange couplings or separable flange couplings.

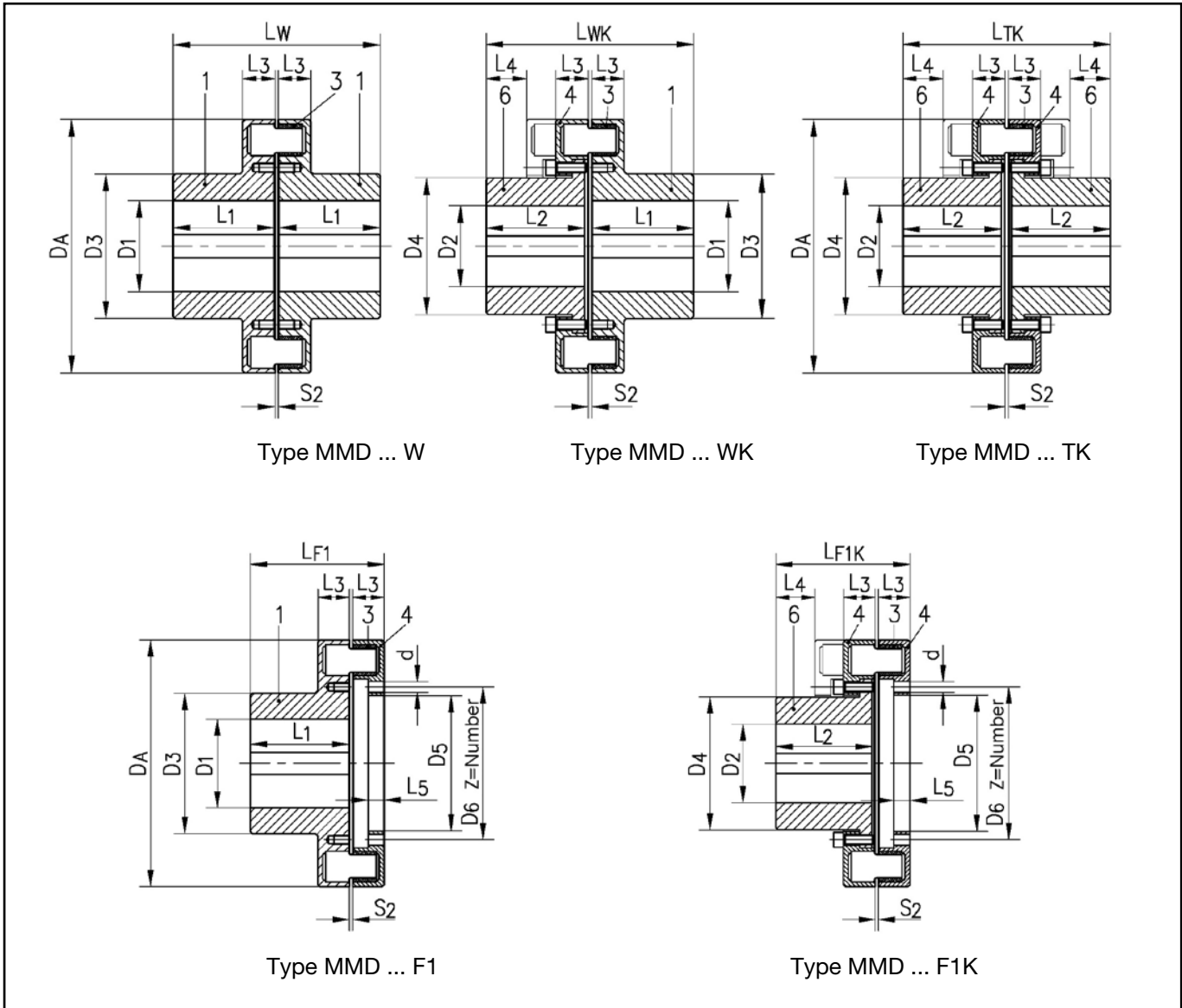

Coupling size	D_A	D_1 [mm]	D_2 [mm]	D_3	D_4	D_5	D_6	z x d	L_1	L_2	L_3	L_4	L_5	L_{F1}	L_W	S_2 ±2 mm		
	mm	pilot bored mm	max. bored mm	mm	mm	mm	mm		mm	mm	mm	mm	mm	mm	mm		mm	
MMD 4000	490	100	190	110	180	285	270	280	310	18 x 22	200	195	64	80	32	273	410	7
MMD 6300	580	120	220	120	210	330	285	315	360	18 x 26	230	225	74	90	37	314	472	8
MMD 10000	650	135	250	140	240	375	360	370	410	18 x 26	255	250	88	90	45	356	525	10

Weights and moments of inertia

Coupling size	MMD ... W		MMD ... WK		MMD ... TK		MMD ... F1K		Hub with flange parts 6/4/1/2 part 3		Flange part 4/1/2 part 3	
	m_{total} kg	J_{total} kgm ²	m_{total} kg	J_{total} kgm ²	m_{total} kg	J_{total} kgm ²	m_{total} kg	J_{total} kgm ²	m_1 kg	J_1 kgm ²	m_2 kg	J_2 kgm ²
MMD 4000	209	4.82	200	4.63	190	4.44	130	3.63	95	2.22	35	1.41
MMD 6300	351	11.06	338	10.73	324	10.40	223	8.59	162	5.20	61	3.39
MMD 10000	512	20.63	494	19.99	476	19.35	326	15.95	238	9.67	88	6.27

The specified values apply to hubs with medium-sized bore diameters

MULTI MONT GIGANT standard types

Designed as shaft and flange couplings

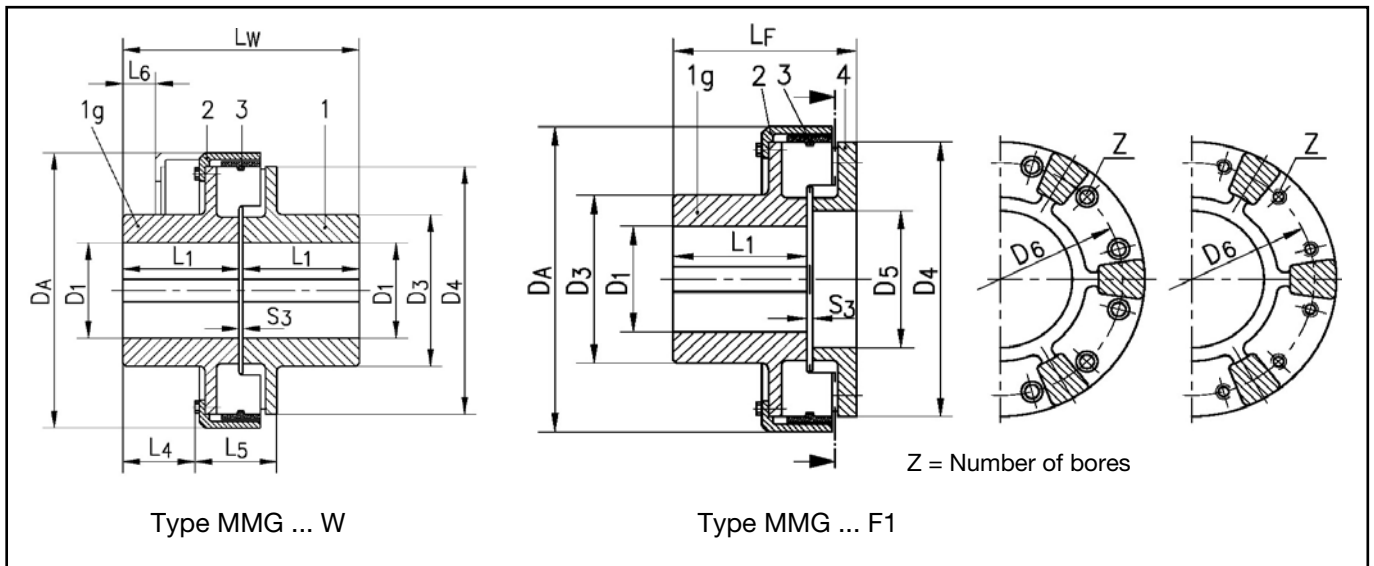

The flexible elements can be easily accessed and removed radially with no need for axial movement of the coupled machines after the retaining cap has been released and withdrawn.

The flanges are supplied without connection bores as a standard. If requested, the flanges can be designed with connection bores for socket head screws or threads acc. to specification on a pitch circle diameter D_6 .

Coupling size	D_A mm	pilot bored	D_1 [mm]		D_3 mm	D_4 h_8 mm	D_5 H_8 mm	L_1 mm	L_4 mm	L_5 mm	L_6 mm	L_F mm	L_W mm	S_3 mm
			max. (GG 25)	0.7040 (GGG 40)										
MMG 4000	553	110	180	200	300	500	250	230	145	160	64	316	468	8
MMG 6300	636	120	205	225	340	572	275	255	163	176	54	350	519	9
MMG 10000	725	1) 110	235	260	390	652	305	285	173	210	58	390	580	10
MMG 16000	832		265	290	435	754	350	310	172	268	35	440	635	15
MMG 25000	938		300	330	505	852	380	345	204	336	48	508	710	20
MMG 40000	1150		350	380	580	1050	460	385	224	378	35	572	792	22
MMG 63000	1250		400	440	670	1180	580	440	260	430	50	650	905	25
MMG 100000	1400		475	520	780	1320	600	510	270	520	40	760	1050	30

1) Pilot bore corresponds to finished bore

Weights and moments of inertia

Coupling size	MMG ... W		MMG ... F1		Hub with ret. cap parts 1g / 2 / 3		Hub part 1		Flange part 4	
	m_{total} kg	J_{total} kgm ²	m_{total} kg	J_{total} kgm ²	m_1 kg	J_1 kgm ²	m_2 kg	J_2 kgm ²	m_2 kg	J_2 kgm ²
MMG 4000	312	8.1	232	4.8	172	5.1	140	3.0	60.0	2.34
MMG 6300	462	15.8	349	14.6	255	10.0	206.6	5.8	93.1	4.7
MMG 10000	558	29.5	446	26.9	316	19.0	242	10.5	129.6	8.0
MMG 16000	868	61.7	696	56.2	489	39	379	22.7	207	17.2
MMG 25000	1144	99.6	984	98.8	641	62.5	503	37.1	343	36.3
MMG 40000	2027	274.5	1747	271	1150	176	877	98.5	597	95
MMG 63000	3462	457	2703	434	1912	286	1550	171	791	148
MMG 100000	5661	995	4370	924	3096	604	2565	391	1274	320

The specified values apply to hubs with medium-sized bore diameters

Mounting instructions and alignment tolerances

The specified alignment tolerances should only be considered as approximate values in order to keep the assembly work involved within reasonable limits and in view of the fact that the compensating capability of the coupling depends to a large extent on the rotational speeds and loads applied. Precise alignment of the coupling halves contributes to a long service life of the flexible coupling elements.

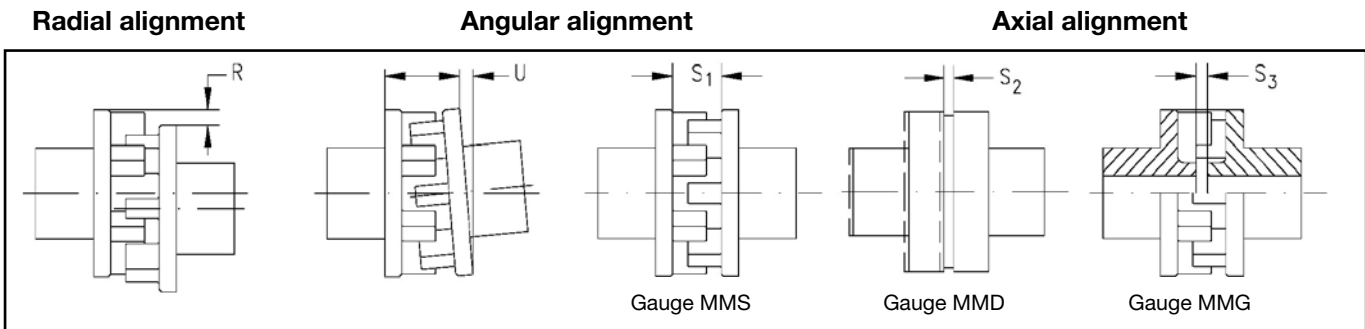

MMS Series

Size	4 ¹⁾	6,3 ¹⁾	10	16	25	40	63	100	160	250	400	630	1000	1600	2500
R _{max} [mm]	0.3	0.3	0.3	0.3	0.3	0.4	0.4	0.4	0.4	0.5	0.5	0.6	0.7	0.8	0.8
U _{max} [mm]	0.3	0.3	0.3	0.4	0.4	0.4	0.5	0.6	0.7	0.8	0.9	1.0	1.1	1.2	1.2
S ₁ ± [mm]	18 ± 1	20 ± 1	17 ± 1	19 ± 1	22 ± 1	26 ± 1	30 ± 1	35 ± 1	41 ^{+1.2} ₋₁	47 ^{+1.5} ₋₁	56 ^{+1.5} ₋₁	64 ^{+1.5} ₋₁	75 ⁺² ₋₁	85 ⁺² ₋₁	110 ⁺² ₋₁

¹⁾ applies to MMS-A

MMD Series

Size	4000	6300	10000
R _{max} [mm]	0.8	0.9	1.0
U _{max} [mm]	1.0	1.1	1.2
S ₂ ± [mm]	7 ± 2	8 ± 2	10 ± 1

MMG Series

Size	4000	6300	10000	16 000	25 000	40 000	63 000	100 000
R _{max} [mm]	0.9	1.0	1.0	1.2	1.4	1.6	2.0	2.0
U _{max} [mm]	1.3	1.4	1.5	1.8	2.1	2.4	2.7	3.0
S ₃ ± [mm]	8 ± 1.5	9 ± 1.5	10 ± 2	15 ± 2	20 ± 2.5	22 ± 3	25 ± 3	30 ± 4

How to mount the flexible elements and the retaining cap

When mounting the flexible elements care shall be taken to ensure that the coupling halves are not mounted too close to each other in order to protect the flexible elements from being subjected to lateral pressure and to maintain the axial flexibility of the coupling in operation. Likewise, the coupling halves shall not be mounted too far from each other so that the rubber blocks are capable of transmitting over the entire width between the coupling claws.

For easier positioning of the retaining cap when the saddle elements are inserted we recommend to previously coat their periphery with talcum or soft soap (no grease or oil). A threaded rod may be used as an aid for pushing the retaining cap into position.

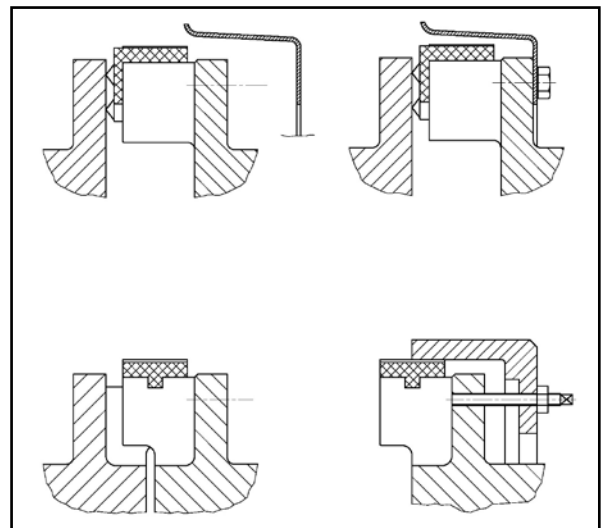

Mounting instruction for type MMS-T...W with taper bush.

Mounting the element hub with taper bush. The general mounting instruction for the MMS also applies to this instruction and is to be equally taken into account.

1. The outer taper of the taper bush and the bore with the inner taper of the element hub shall show bright metal and must be free of grease prior to mounting. Preservatives must be removed completely.

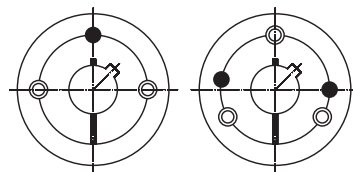

Fig. 1

No.1610
2012
2517
3030

No. 3535
4040
4545

2. Insert the taper bush into the element hub and line up all connecting bores. Make sure that half threaded holes coincide with half plain bores (Fig. 1).

3. Screw in lightly greased or oiled assembly screws. Do not tighten the screws yet (Fig. 2).

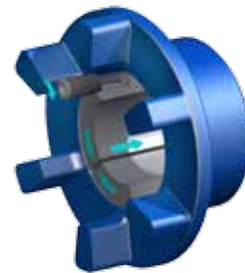

Fig. 2

4. Slide the element hub with inserted taper bush onto the cleaned shaft with key. Put it into the mounting position and tighten it uniformly according to Fig. 3 and Table 1.

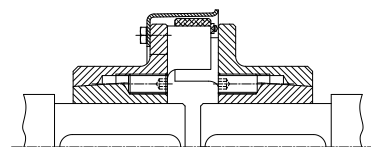

Fig. 3

5. The screws can be retightened again by slight tapping against the taper bush with a hammer using an intermediate plate. Repeat this process, if necessary.

Dismantling the element hub with taper bush

1. Loosen and remove all screws. Depending on the taper bush size, screw either 1 or 2 greased screws into the half pulling-off thread(s) of the taper bush (Fig. 4).

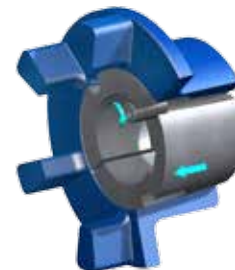

Fig. 4

2. Tighten the screws uniformly until the taper bush is loose in the element hub.

3. As soon as the taper bush is loose, the element hub can be pulled off the shaft together with the taper bush.

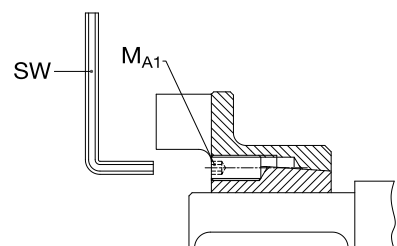

Table 1

Screw tightening torques for mounting the taper bush

Coupling size	MMS 25	MMS 40	MMS 63	MMS 100/160	MMS 250	MMS 400/630	MMS 1000
Taper bush No.	1610	2012	2517	3030	3535	4040	4545
B.S.W. screw size *)	$\frac{3}{8} \times 16$	$\frac{7}{16} \times 22$	$\frac{1}{2} \times 25$	$\frac{5}{8} \times 32$	$\frac{1}{2} \times 38$	$\frac{5}{8} \times 45$	$\frac{3}{4} \times 50$
Tightening torque M_{A1} [Nm]	20	31	49	92	115	172	195
Width across flats SW [mm]	5	6	6	8	10	12	14

*) Nr.1610/2012/2517/3030 set screw Nr.3535/4040/4545 cap screw