

# LabSmith Automated Valves

- ▶ Automatically switched fluid routing
- ▶ Low swept volume
- ▶ Fast switching
- ▶ Innovative software for coordinated control
- ▶ Direct connection to 1/32" or 1/16" tubing, or 360 µm OD capillary
- ▶ Compatible with a wide range of chemicals



Automated valve  
actual size

Model	Swept Volume	Valve Volume	Through Hole Diameter	Capillary or Tubing Interface
AV201-C360	130 nl	170 nl	0.01" (250 µm)	360 µm OD (via p/n C360-100)
AV201-T132	130 nl	170 nl	0.01" (250 µm)	1/32" OD (via p/n T132-100)
AV201-T116	130 nl	280 nl	0.01" (250 µm)	1/16" OD (via p/n T116-100)
AV202-C360	90 nl *	130 nl *	0.01" (250 µm)	360 µm OD (via p/n C360-100)
AV202-T132	90 nl *	130 nl *	0.01" (250 µm)	1/32" OD (via p/n T132-100)
AV202-T116	90 nl *	130 nl *	0.01" (250 µm)	1/16" OD (via p/n T116-100)
AV2X2-T116	130 nl	280 nl	0.01" (250 µm)	1/16" OD (via p/n T116-100)
AV303-C360	60 nl *	100 nl *	0.01" (250 µm)	360 µm OD (via p/n C360-100)
AV303-T132	60 nl *	100 nl *	0.01" (250 µm)	1/32" OD (via p/n T132-100)
Model	Internal Volume	Through Hole Diameter	Capillary or Tubing Interface	
AV801-C360	370 nl	0.01" (250 µm)	360 µm OD (via p/n C360-100)	
AV801-T132	370 nl	0.01" (250 µm)	1/32" OD (via p/n T132-100)	
AV801-T116	2.8 µl	0.02" (500 µm)	1/16" OD (via p/n T116-100)	

\* Per leg

Model	Port Configuration	Typical Application
201	3 port, 2 position (+ closed), "L" pattern flow	Redirecting flow
202	4 port, 2-position (+ closed), two simultaneous flow streams between adjacent ports.	Continuous dispensing/refilling (with Breadboard reservoir and two SPS01 syringe pumps)
2X2	4 port, 2-position (+ closed), cross flow	Stop flow, switching between reagents
303	6 port, 2-position (no closed option), three simultaneous flow streams between adjacent ports	Sample injection
801	9-port, 8-position, one common port	Select from multiple reagents and/or direct to multiple outputs

<b>Wetted Material</b>	Vespel. <sup>®</sup> Select valves available in PCTFE (contact LabSmith)
<b>Switch Time</b>	AV201, 202, 2X2, 303: 0.65-0.78 s (A-B or B-A); 0.25-0.50 s (closed-A or closed-B) AV801: 1.25-2.75 s. Time depends on whether ports are adjacent or spaced. Valve switches in counterclockwise direction only. For example, switching from port 1 to 2, switch time ~ 1.25 sec; from port 2 to 1, switch time ~ 2.75 sec
<b>Actuation method</b>	Gear motor
<b>Cleaning</b>	Flush valve ports with DI water or solvent
<b>Service Temperature Range</b>	50-176°F (10-80°C)
<b>Maximum Pressure</b>	2000 psi (14 MPa)
<b>Electrical Connection</b>	Connects to 4VM02 valve manifold via flat flex ribbon cable

Valve Accessories	
<b>4VM02 Valve Manifold</b>	Required. For connecting up to 4 automated valves; includes 4 flat flex connector cables.
<b>EIB200 Automation Interface</b>	Required for control of 4VM02 valve manifold via uProcess™ software; includes software, LabVIEW™ drivers, and SDK
<b>Breadboard</b>	Optional platform for mounting AV series valves, 4VM02, and other microfluidic devices. p/n uPB-05, uPB-08, uPB-12, or iBB.
<b>Mounting Hardware</b>	Set of 20 thread-forming screws (2-28-1/4") to mount 10 valves or reservoirs to breadboard. p/n LS-SCREWS.25.
<b>One-piece Fittings</b>	Required for connection to capillary or tubing. p/n C360-100, T132-100, or T116-100.

## AV201

3 port, 2 position (+ closed), "L" pattern flow.

### Configurations

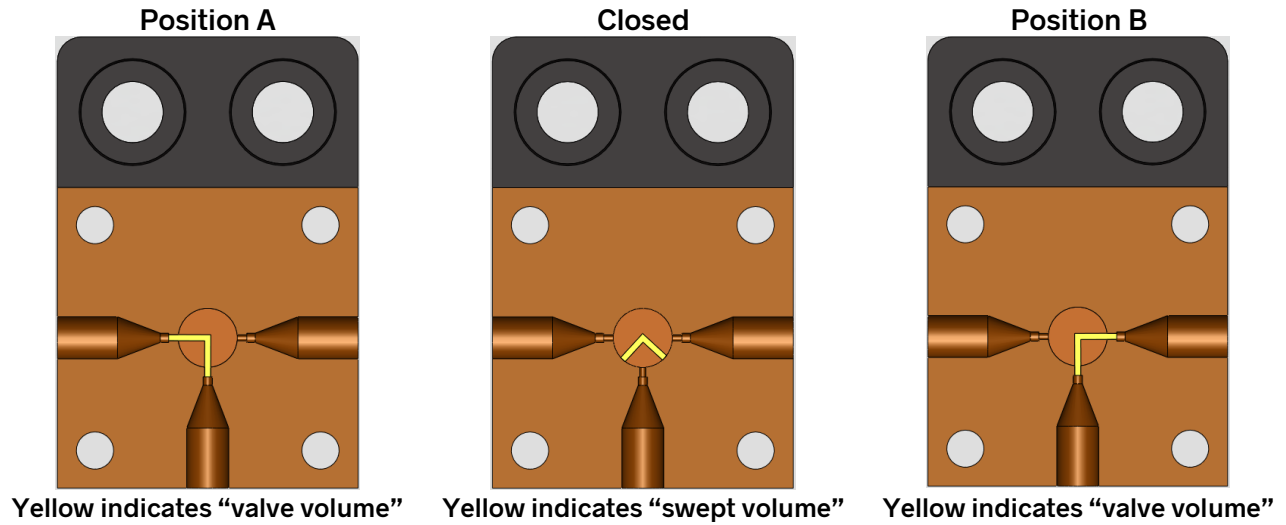

### Dimensions

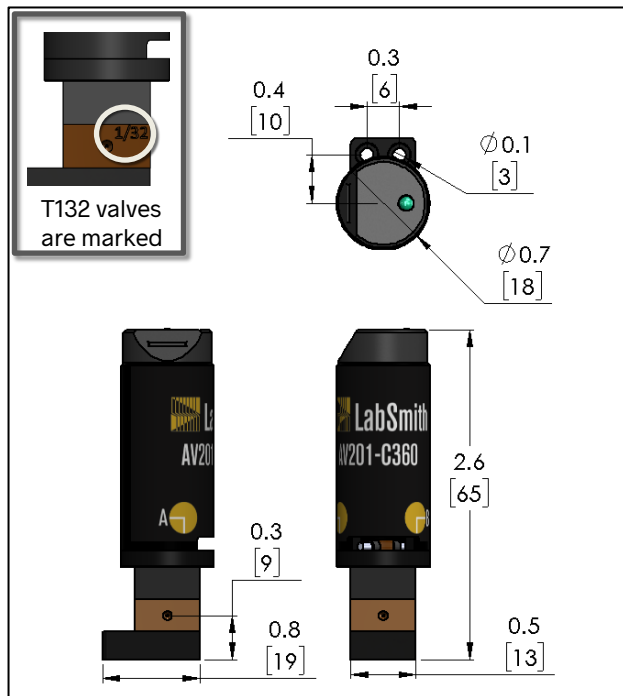

AV201-C360  
AV201-T132

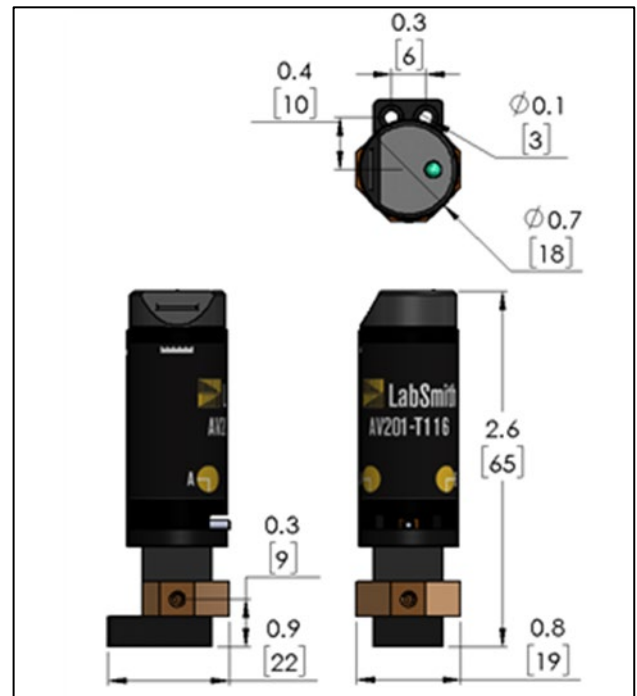

AV201-T116

## AV202

4 port, 2-position (+ closed), two simultaneous flow streams between adjacent ports.

### Configurations

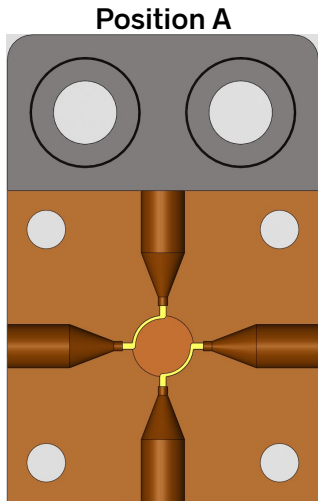

Position A

Yellow indicates "valve volume"

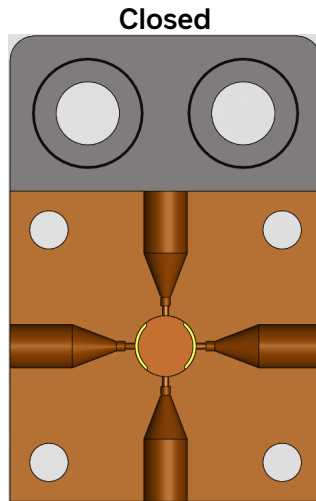

Closed

Yellow indicates "swept volume"

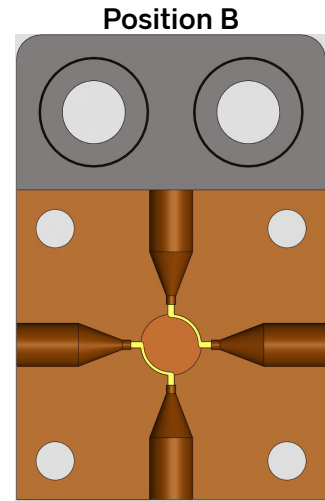

Position B

Yellow indicates "valve volume"

### Dimensions

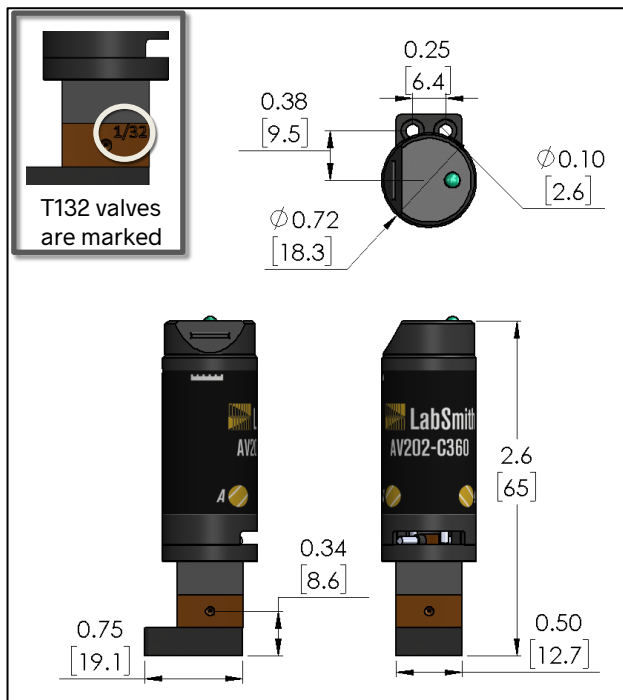

AV202-C360  
AV202-T132

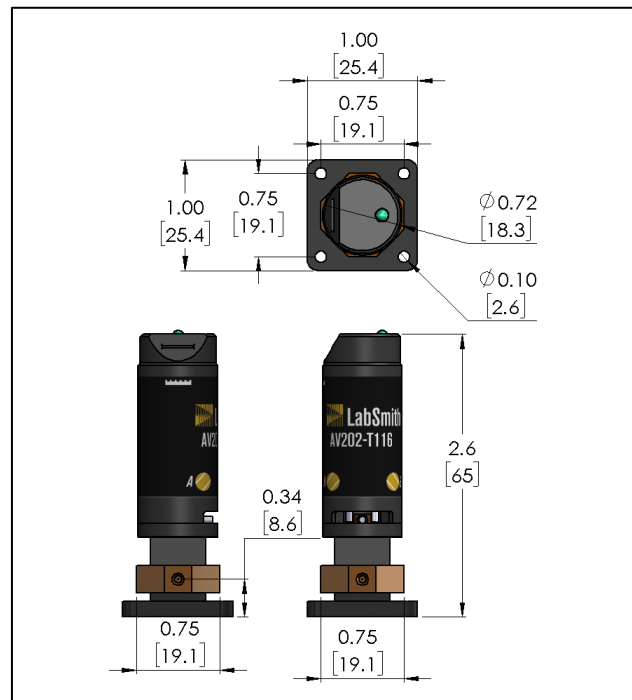

AV202-T116

## AV2X2

3 port, 2 position (+ closed), cross flow.

### Configurations

Position A

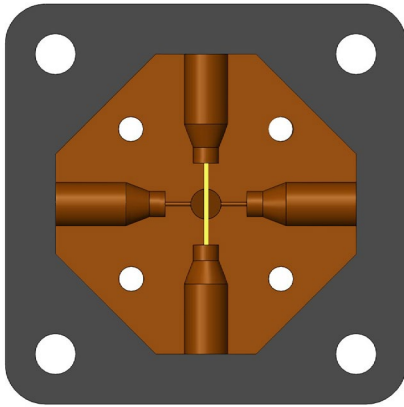

Valve Front

Yellow indicates “valve volume”

Closed

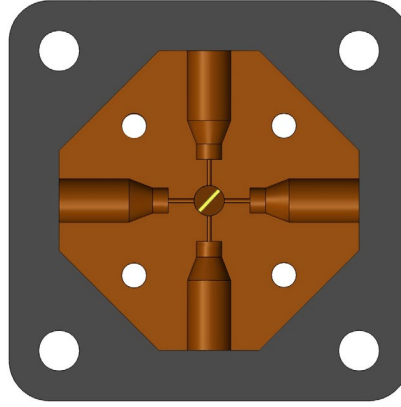

Valve Front

Yellow indicates “swept volume”

Position B

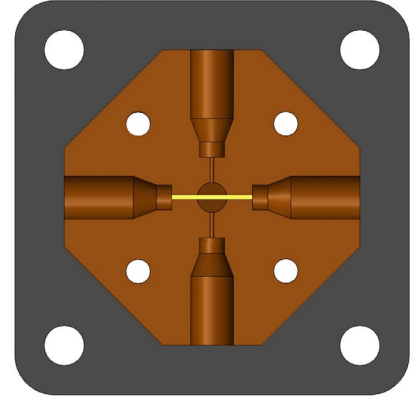

Valve Front

Yellow indicates “valve volume”

### Dimensions

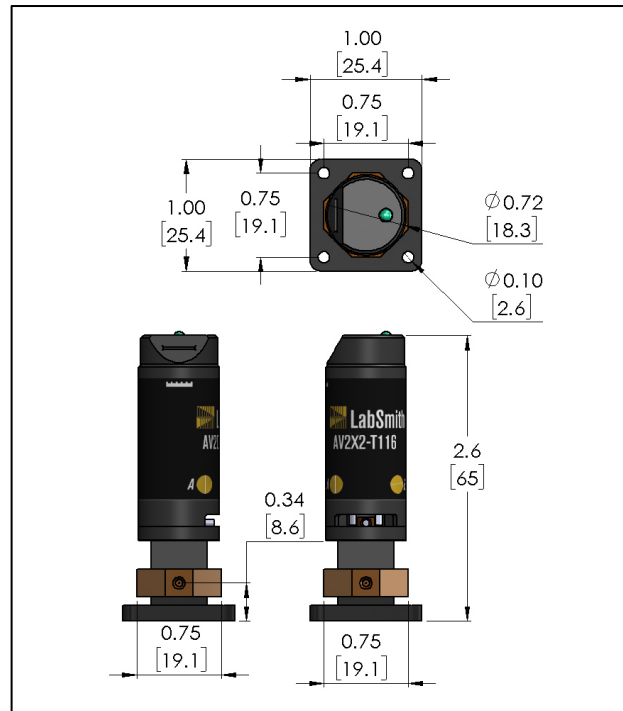

AV2X2-T116

## AV303

6 port, 2-position (no closed option), three simultaneous flow streams between adjacent ports.

### Configurations

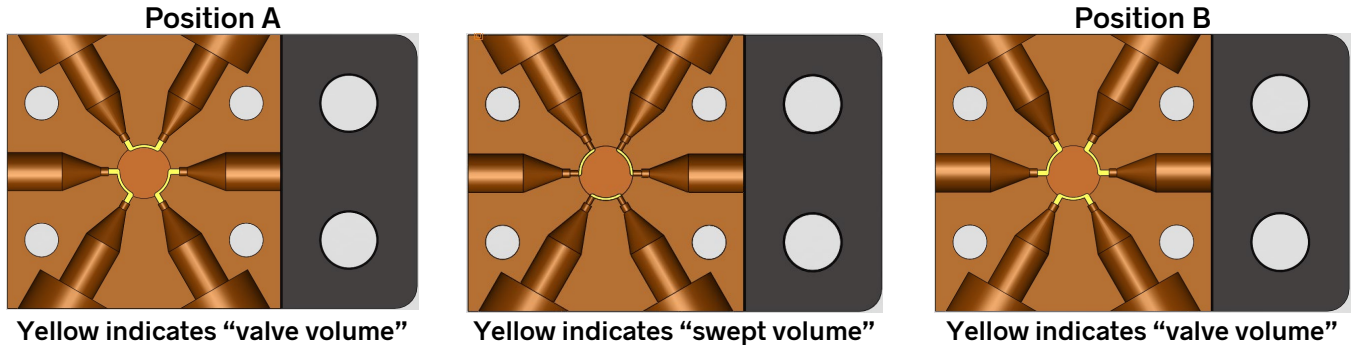

### Dimensions

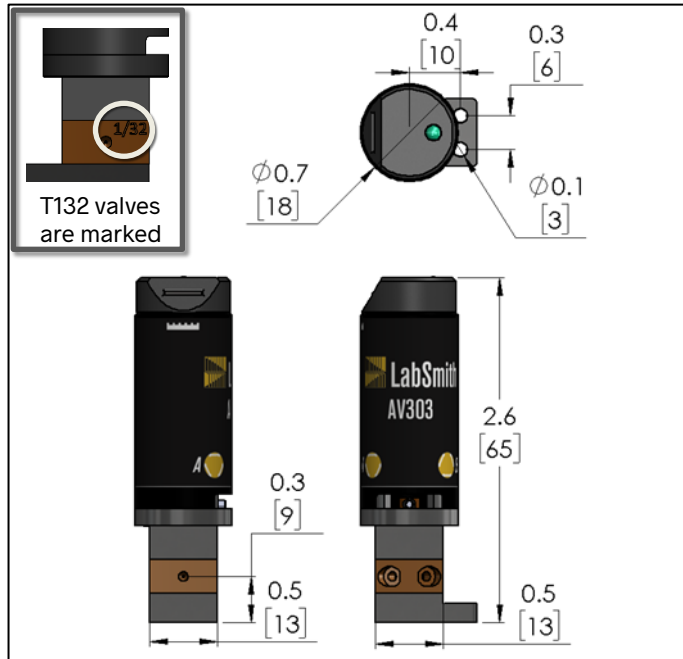

AV303-C360  
AV303-T132

## AV801

9-port, 8-position, one common port

### Configurations

Top view showing selector ports

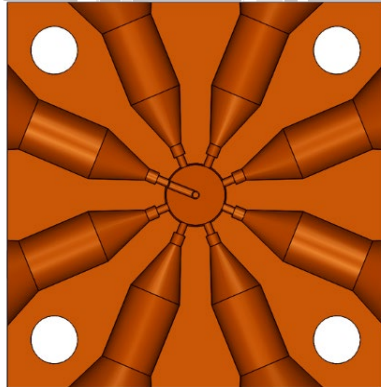

Side view showing common port and stem

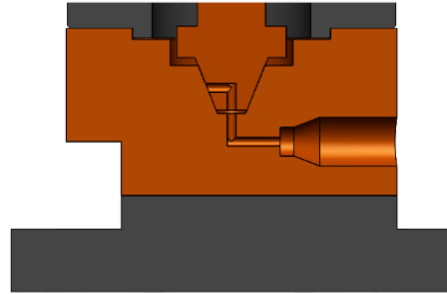

### Dimensions

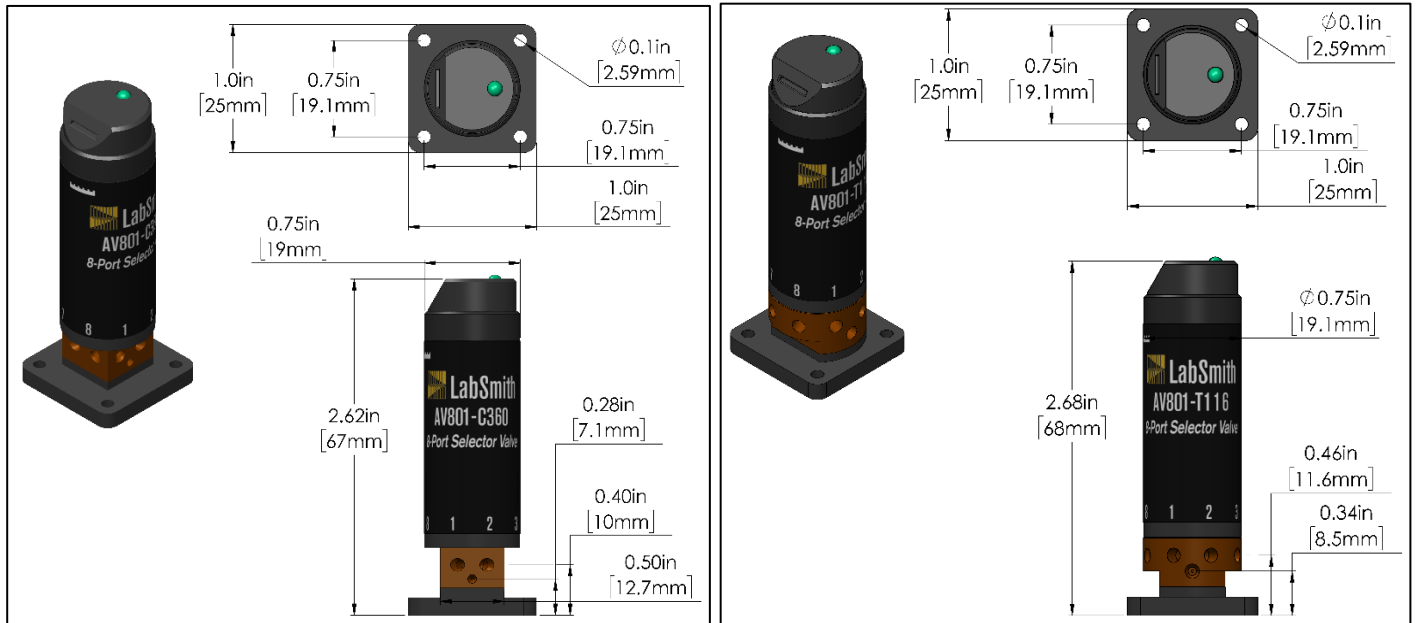

AV801-C360  
AV801-T132

AV801-T116

Some valve models are available in manual versions. See the MV Series Manual Valves spec sheet for more information.

3D models available upon request

