

Ajax

Series **XP** FLAMEPROOF LIQUID LEVEL ALARM

(for Local or Remote Mounting).



CE
0518



I M2 / II 2G
EExd I / IIB + H₂ T6

- **SIRA** Certificate No: 03ATEX1507 Issue 1
EU Directive 94/9/EC (ATEX Directive)
CENELEC EN 50014, EN50018
(Zones 1 and 2 Hazardous Areas)
- **Weatherproof Enclosure in BS EN 1982 LG2/LG4
or Stainless Steel BS 3100 316C16.**
Environmental Protection Approval to IP66
according to IEC-144.
- **Versatility of Switching Circuits.**
- **Rugged Construction, Vibration and Shock Resistant.**
- **Totally self contained.**

The Bamford Ajax XP series of Flameproof Liquid Level Alarm controls are a new generation of ruggedly constructed devices for automatic control and reliable protection of machinery and plant in hazardous areas. It is a compact unit that can be mounted either directly on a tank, crankcase, gear case, etc., or remote at a convenient point by using interconnecting piping. The unit is ideal for indicating low lubricating oil level in a sump or leakage from fuel injection piping. The functionally designed enclosure is standard on all models to meet the arduous conditions experienced in the petro-chemical and offshore industries. Single or double cable entries are available for fitting with approved glands.

The totally enclosed float mechanism operates on eccentrically mounted pivot and actuates, via a metallic bellows seal, an internally adjusted microswitch or switches. The standard precision snap action micro-switch is a single pole double throw type; however, one or two microswitches with silver plated noble metal contacts may be fitted to provide versatility of switching circuits. The material of the wetted parts caters for the majority of liquids.

F. Bamford (Instruments) Ltd.

Ajax Works,
Whitehill,
Stockport, SK4 1NT. United Kingdom.

Telephone: 0161-480 6507

Fax: 0161-474 7990

Web: www.bamfordinstruments.com

Email: sales@bamfordinstruments.com

Specifications

SWITCH RATING (STANDARD)

VOLTS	DC		AC	
	RES	IND	RES	IND
30	10A	10A	10A	10A
125	0.5A	0.07A	10A	10A
250	0.25A	0.03A	10A	10A

Alternative switches may be fitted for 440 volts or intrinsic safe circuits.

Conduit entry

Either one or two M20 or M25 x 1.5 pitch.

Connector size: 0.5mm²

Earthing Screw: M5.

Ambient Temperature Range of Switch

Enclosure: -20°C to +40°C

Maximum Operating Temperature Range

of Working Medium: -10°C to +93°C

Maximum Working Pressure: 14.5 BAR G

Float housing:

Gunmetal BS EN 1982 LG2/LG4

Switch Housing:

Manufactured in either:

Gunmetal BS EN 1982 LG2/LG4

Stainless Steel BS 3100 316C16

Wetted parts:

Brass BS 2874 CZ121

Fluid Connections:

3/4" BSP Female

Dimension Drawing



Certificate No: FM 13215

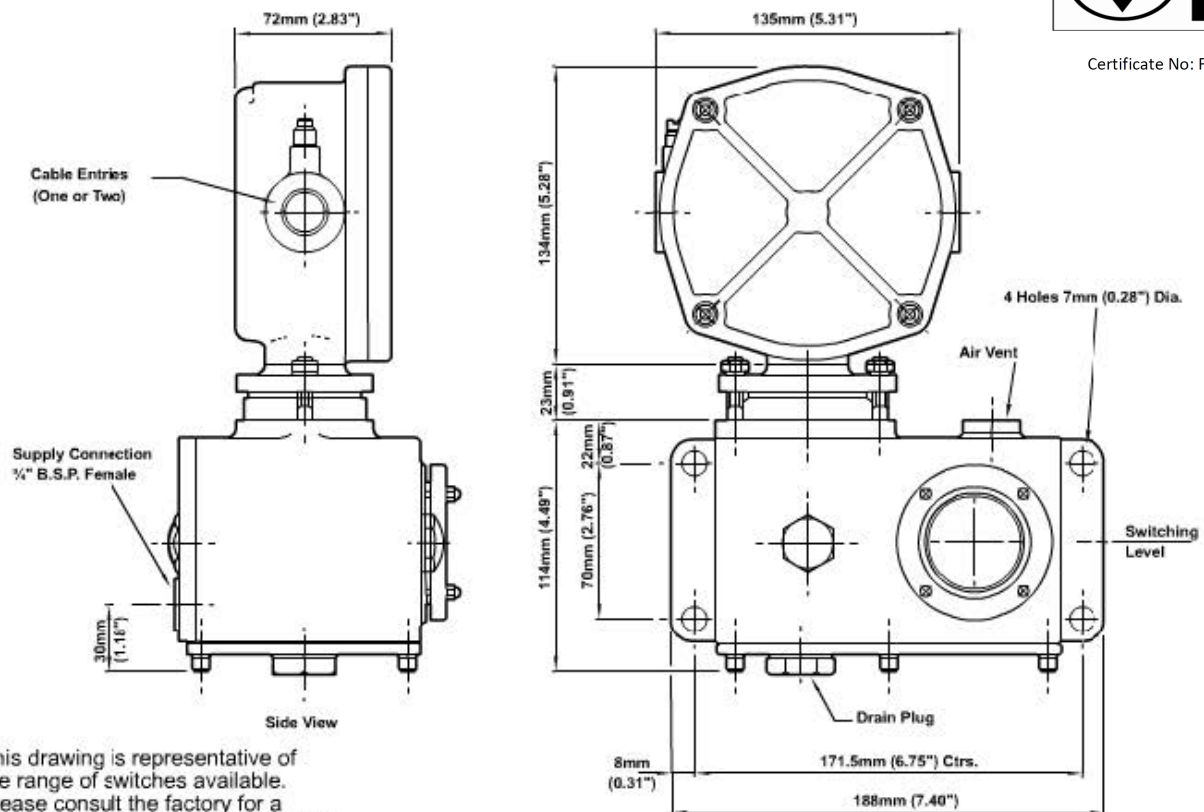

This drawing is representative of the range of switches available. Please consult the factory for a detailed drawing/specification sheet.