



Torque range: 0.1 - 70 Nm

OPERATOR MANUAL



IDENTIFICATION DATA OF THE MANUFACTURER

KOLVER S.r.l.

VIA DELL'ELETTRONICA, 14/16

36016 THIENE (VI) ITALIA

IDENTIFICATION DATA OF THE PRODUCT

KDU CONTROLLER

Code	Model
035001/A	KDU-1A

KDS SCREWDRIVER

Code	Model	Torque (Nm)	Speed (rpm)	
			Min	Max
175015/ESD	KDS-MT1.5	0.1 - 1.5	50	850
175016/ESD	KDS-MT1.5P	0.1 - 1.5	50	850
175016/U/ESD	KDS-MT1.5P/U	0.1 - 1.5	50	850
175115	KDS-MT1.5CA	0.1 - 1.5	50	850
175115/FN	KDS-MT1.5CA/FN	0.1 - 1.5	50	850
175015/A/ESD	KDS-MT1.5ANG	0.1 - 1.5	50	850
135003/ESD	KDS-PL3	0.4 - 3	50	1800
135004/ESD	KDS-PL3P	0.4 - 3	50	1800
135004/U/ESD	KDS-PL3P/U	0.4 - 3	50	1800
135103	KDS-PL3CA	0.4 - 3	50	1800
135103/FN-1/4	KDS-PL3CA/FN-1/4	0.4 - 3	50	1800
135003/A/ESD	KDS-PL3ANG	0.4 - 3	50	1800
135006/ESD	KDS-PL6	0.5 - 6	50	850
135007/ESD	KDS-PL6P	0.5 - 6	50	850
135007/U/ESD	KDS-PL6P/U	0.5 - 6	50	850
135106	KDS-PL6CA	0.5 - 6	50	850
135106/FN	KDS-PL6CA/FN	0.5 - 6	50	850
135006/A/ESD	KDS-PL6ANG	0.5 - 5.5	50	850
135010/ESD	KDS-PL10	0.8 - 10	50	600
135011/ESD	KDS-PL10P	0.8 - 10	50	600
135011/U/ESD	KDS-PL10P/U	0.8 - 10	50	600
135110	KDS-PL10CA	0.8 - 10	50	600
135110/FN	KDS-PL10CA/FN	0.8 - 10	50	600
135010/A/ESD	KDS-PL10ANG	0.8 - 9	50	600
135015/ESD	KDS-PL15	0.5 - 15	50	320
135016/ESD	KDS-PL15P	0.5 - 15	50	320
135016/U/ESD	KDS-PL15P/U	0.5 - 15	50	320
135115	KDS-PL15CA	0.5 - 15	50	320
135115/FN	KDS-PL15CA/FN	0.5 - 15	50	320
135015/A/ESD	KDS-PL15ANG	0.5 - 14	50	320
135020	KDS-PL20	2 - 20	20	210
135120	KDS-PL20CA	2 - 20	20	210
135120/FN	KDS-PL20CA/FN	2 - 20	20	210
135030/ANG	KDS-PL30ANG	3 - 30	20	140
135035	KDS-PL35	3 - 35	20	140
135135	KDS-PL35CA	3 - 35	20	140

135135/FN	KDS-PL35CA/FN	3 - 35	20	140
135045/ANG	KDS-PL45ANG	4 - 45	20	90
135050	KDS-PL50	5 - 50	20	90
135150	KDS-PL50CA	5 - 50	20	90
135150/FN	KDS-PL50CA/FN	5 - 50	20	90
135070/ANG	KDS-PL70ANG	7 - 70	10	50

TECHNICAL DATA OF THE PRODUCT

KDU CONTROLLER

FUSE: 3,15 A

DIMENSIONS: 190 x 205 x h120 mm

WEIGHT: 2,5 Kg

POWER SUPPLY: 90÷260 V AC 50÷60 Hz

TENSION: 40V DC

POWER: 600W

KDS SCREWDRIVER

DIMENSIONS: 254-453 x 40-50 mm

WEIGHT: 0,7 – 2,8 Kg

VOLTAGE: 40V DC

POWER: 600W

NOISE LEVEL: < 70 dB(A)

VIBRATION LEVEL: < 2.5 m/s²

DECLARATION OF CONFORMITY



KOLVER S.r.l. declares that the new tool here described: control unit model KDU-1A is in conformity with the following standards and other normative documents: 2006/42/CE, LVD 2014/35/UE, EMCD 2014/30/UE, EN 62841-2-2:2014, EN 62841-1: 2015, EN 60204-1, EN 61000-6-2, EN 61000-6-4.

It is also in conformity with RoHS III normative (2011/65/UE and following 2015/863).

Name: Giovanni Colasante

Position: General Manager

Person authorized to compile the technical file in Kolver

Thiene, January 1st 2022

Giovanni Colasante

DECLARATION OF USE

Screwdriver (class I) suitable for industrial environment only. It shall be used for tightening. No other use will be permitted. For professional use only.

WARNING: To reduce the risk of injury, before using or servicing screwdriver, read and understand the following information as well as separately provided safety instructions (item code: 0MS000). The features and descriptions of our products are subject to change without prior notice.

DECLARATION OF NOISE AND VIBRATION EMISSION

NOISE LEVEL: < 70 dB(A)

VIBRATION LEVEL: < 2.5 m/s²

These declared values were obtained by laboratory type testing in compliance with the stated standards and are not adequate for use in risk assessments. Values measured in individual work places may be higher than the declared values. The actual exposure values and risk of harm experienced by an individual user are unique and depend upon the way the user works, the work piece and the workstation design, as well as upon the exposure time and the physical condition of the user. We, KOLVER, cannot be held liable for the consequences of using the declared values, instead of values reflecting the actual exposure, in an individual risk assessment in a work place situation over which we have no control.

OPERATING MODE

The screwdriver can be manual or used as fixed spindle on an automatic machine.

CONTROL UNIT

KDU-1A

MAINTENANCE

Maintenance should be performed by qualified personnel only.

- Prior to any maintenance task: disconnect the screwdriver.
- When disassembling / reassembling the screwdriver, take the following precautions:
 - Check that the controller is switched off.
 - Disconnect the cable.

According to Directive 2012/19/EU concerning Waste Electrical and Electronic Equipment (WEEE), this product must be recycled.

Table of Contents

DECLARATION OF USE	4
INSTALLATION	7
Installation of KDU-1A unit	7
Connectors	8
Installation of KDS screwdriver.....	10
Installation of torque reaction arm	11
QUICK START.....	13
TERMINOLOGY	16
OPERATING THE KDS SCREWDRIVER	18
OPERATING THE K-DUCER CONTROL UNIT	20
Main Screen – Program Mode – navigation tree	20
Main Screen – Sequence Mode – navigation tree	23
Torque and Angle graphing	26
Generating the Torque and Angle graphs from CSV data.....	29
Determining the joint type.....	30
Determining the appropriate program settings	32
Hard/inelastic joints.....	32
Soft/elastic joints.....	32
Screwdriving Phases.....	33
Retrieving and storing the screwdriving results	34
Data format for the screwdriving results	34
Connecting a barcode scanner	37
Connecting a bit-tray or switchbox (CBS880, SWBX88)	38
Connecting a K-TLS smart positioning arm.....	40
CONFIGURING THE K-DUCER	41
ADVANCED TORQUE CONTROL STRATEGIES	41
SEQUENTIAL TORQUE AND ANGLE CONTROL	41
PREVAILING TORQUE / RUNNING TORQUE (PVT/RT).....	42
MAX POWER PHASE.....	44
CROSSTHREAD DETECTION	45
MULTI-STEP AND COMBINED PROGRAMS	46
MAIN MENU	47

PROGRAMS menu	48
TORQUE & ANGLE menu	49
ADVANCED TORQUE menu	51
REVERSE, RAMP, TIME menu.....	53
OTHER menu	55
SEQUENCE SETTINGS menu	59
CURRENT SEQ. menu	60
GENERAL SETTINGS menu.....	62
USB menu.....	69
FREE K-EXPAND, K-LINK, AND K-GRAPH SOFTWARE	71
REMOTE CONTROL INTERFACES.....	72
24V I/O.....	73
Pinout (CN3).....	74
Sequence and program selection via 24V I/O on CN3	80
MODBUS TCP	83
OPEN PROTOCOL	84
Supported MIDs.....	84
MID 2500 instructions	86
TOOLSNET OPEN PROTOCOL	92
PROFINET / Ethernet IP / EtherCAT / others	92
COLLABORATIVE ROBOTS	93
MAINTENANCE AND CARE.....	94
INTRODUCTION	94
CALIBRATION.....	94
MAINTENANCE.....	95
GUARANTEE.....	95

INSTALLATION

Installation of KDU-1A unit

The K-DUCER is supplied with the following mounting bracket (all dimensions reported in mm):

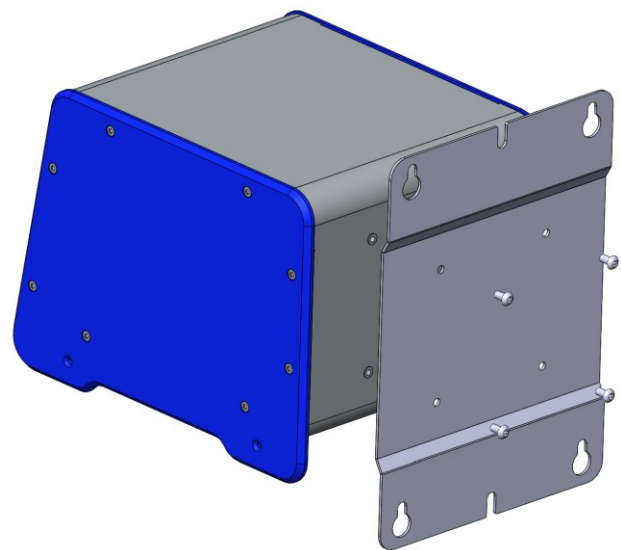
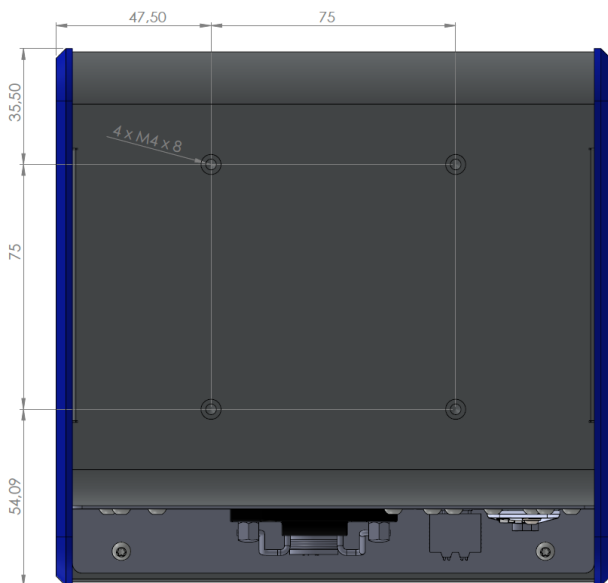
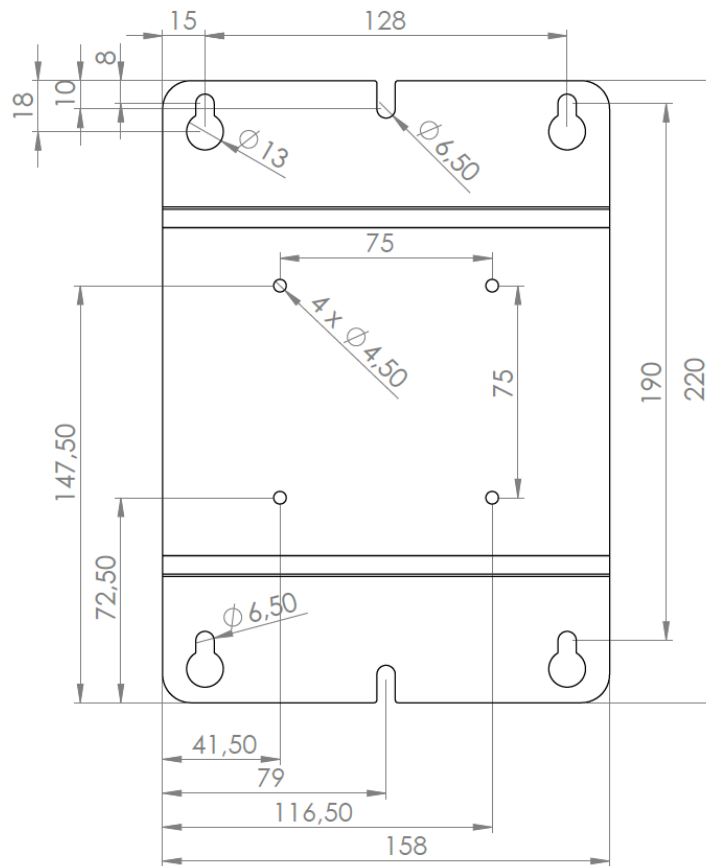

The bracket should be fixed to the four provided 8mm depth female threads on the back panel using the provided M4x8 screws.

Also available separately:

- vertically and horizontally adjustable bracket (part number 010401)
- swivel table stand (part number 010402)

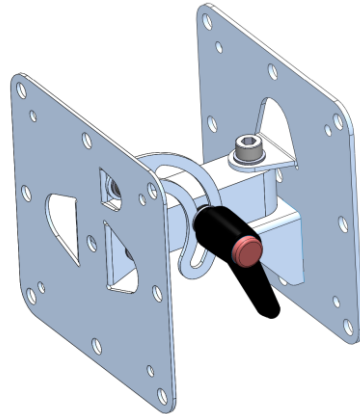

010401

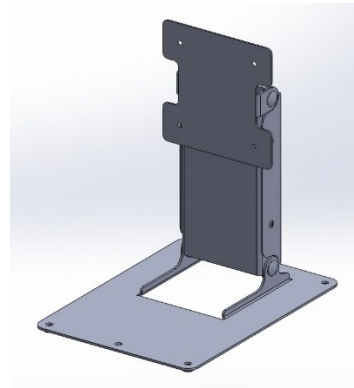

010402

Connectors

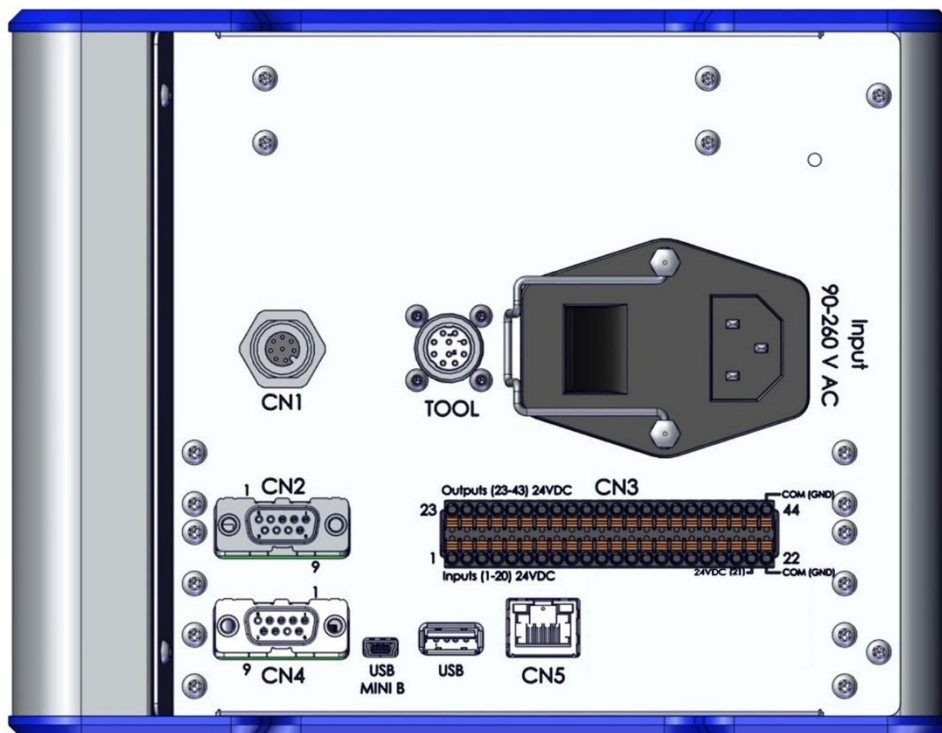

TOOL connector

To connect a KDS series screwdriver. Take care to respect the alignment tabs on the connector. See [Installation of KDS screwdriver](#) section for instructions on connecting the screwdriver.

CN1 connector

Reserved for servicing the unit and upgrading the firmware.

CN2 male serial connector

To connect with a compatible barcode scanner, such as Kolver Barcode P/N 020050 or 020051 or any USB barcode scanner via adapter P/N 010415, serial printers such as Kolver PRNTR1, serial terminals (PC/PLCs), or a K-TLS smart positioning arm.

CN4 female serial connector

To connect with Kolver accessories SWBX88/CBX880, serial printers such as Kolver PRNTR1, serial terminals (PC/PLCs), or a K-TLS smart positioning arm.

CN3 digital I/O connector

To connect with 24V I/O functionality such as PLCs, pedals/buttons, LEDS, etc. Refer to the [REMOTE CONTROL INTERFACES](#) chapter.

CN5 ethernet connector RJ45

To connect using MODBUS TCP, Open Protocol, ToolsNet, or K-Expand from a PLC, PC, or server. Refer to the [REMOTE CONTROL INTERFACES](#) chapter.

USB mini B

To connect using K-Expand software. Refer to the [K-EXPAND software](#) chapter.

USB A

Plug in a FAT32 formatted flash drive to automatically save screwdriving results and backup all settings. Refer to the [Retrieving and storing the screwdriving results](#) and [USB menu](#) sections.

Installation of KDS screwdriver

Cable connection and part numbers

The KDS screwdriver series require one of the following cables:

Code	Description
250064	2.5m (8ft) cord set to connect screwdriver to controller
250064/H	2.5m (8ft) cord set to connect screwdriver to controller with strain relief
250064/A	2.5m (8ft) 90° cord set to connect screwdriver to controller
250564	5m (15ft) cord set to connect screwdriver to controller
250564/H	5m (15ft) cord set to connect screwdriver to controller with strain relief
250564/A	5m (15ft) 90° cord set to connect screwdriver to controller
250564/HS	5m (15ft) spiral reinforced cord set to connect screwdriver to controller
250764	7m (21ft) cord set to connect screwdriver to controller
250764/H	7m (21ft) cord set to connect screwdriver to controller with strain relief

To connect the screwdriver to the unit:

1. taking care to respect the alignment tabs, insert the male connector into the appropriate TOOL connector on the bottom of the unit. Push the connector into its position and turn the nut clockwise, by hand, all the way until it stops, without overtightening or using excessive force.
2. taking care to respect the alignment tabs, repeat the process for the screwdriver end of the cable.

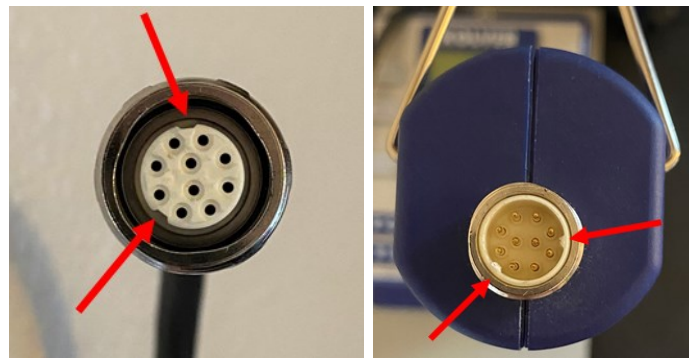

To disconnect the cable:

1. push the connector in lightly towards the screwdriver or the unit
2. turn the nut counterclockwise
3. pull the connector out

Installation of torque reaction arm

Kolver recommends always using a reaction arm for operator comfort, especially for applications with torques above 5 Nm.

Clamp the reaction arm to the screwdriver in the indicated areas only.

Clamping anywhere else may damage the screwdriver and void the warranty.

Clamping areas:

NEVER ALLOWED: middle of handle or middle of CA aluminum body

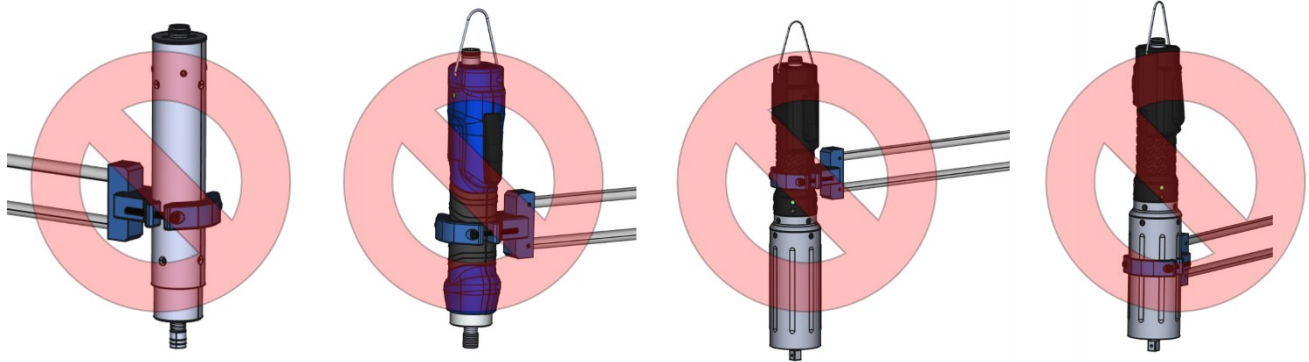

Metal ring area near bit holder (recommended for all models):

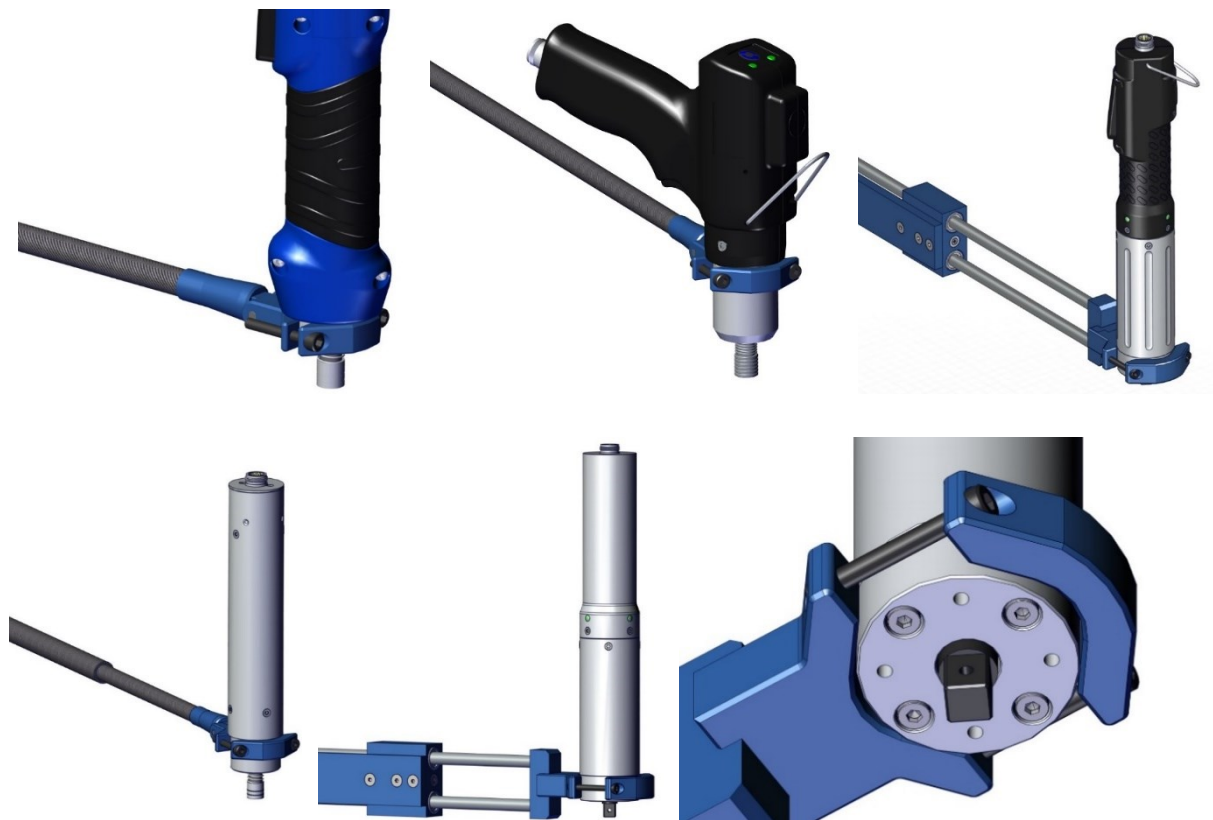

CA screwdrivers can also be installed on a fixture via the provided threaded holes near the bit holder.

Reinforced upper plastic area: allowed only for torque targets up to 10 Nm



If, due to clearance requirements, it is necessary to clamp on the upper plastic area, and the torque target is at or above 10 Nm, use the double-clamping toolholder P/N 010703/L:

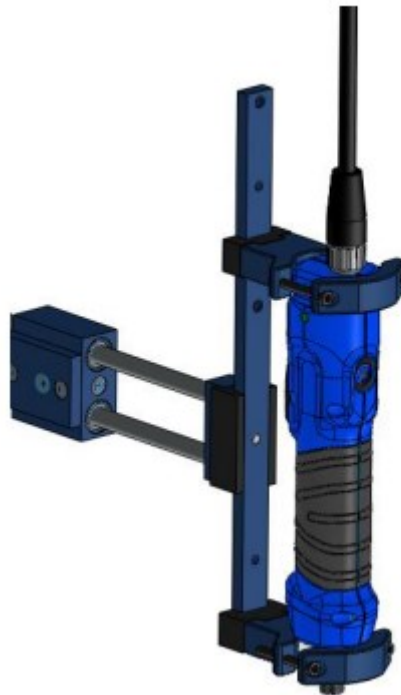

QUICK START

Turn the unit on through the on/off switch on the lower panel. The unit will carry a general system check and the words "NO SCREWDRIVER CONNECTED" will appear if no screwdriver is connected.

You can still enter the main menu without any screwdriver connected.

When a screwdriver is connected, it will be recognized by the unit and the "CONNECTED SCREWDRIVER" screen will appear for a few seconds, also showing the model and serial number.

All information pertaining to the connected screwdriver can also be retrieved in the General Settings menu.

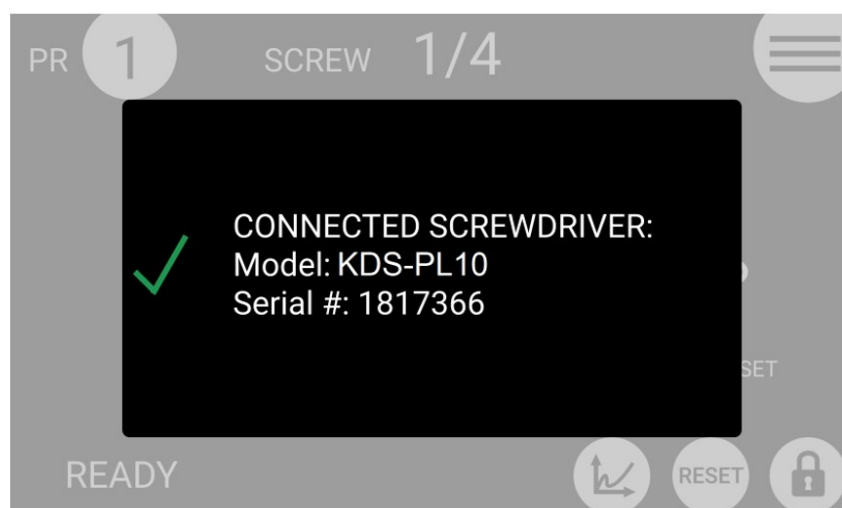
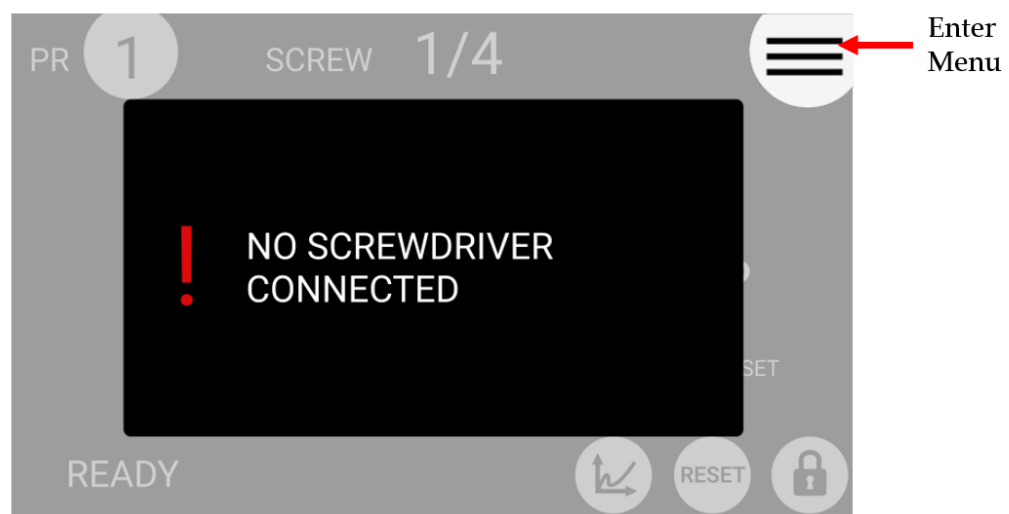

If the parameters set in the current program are outside the allowable range of the connected screwdriver, the following screen will appear:

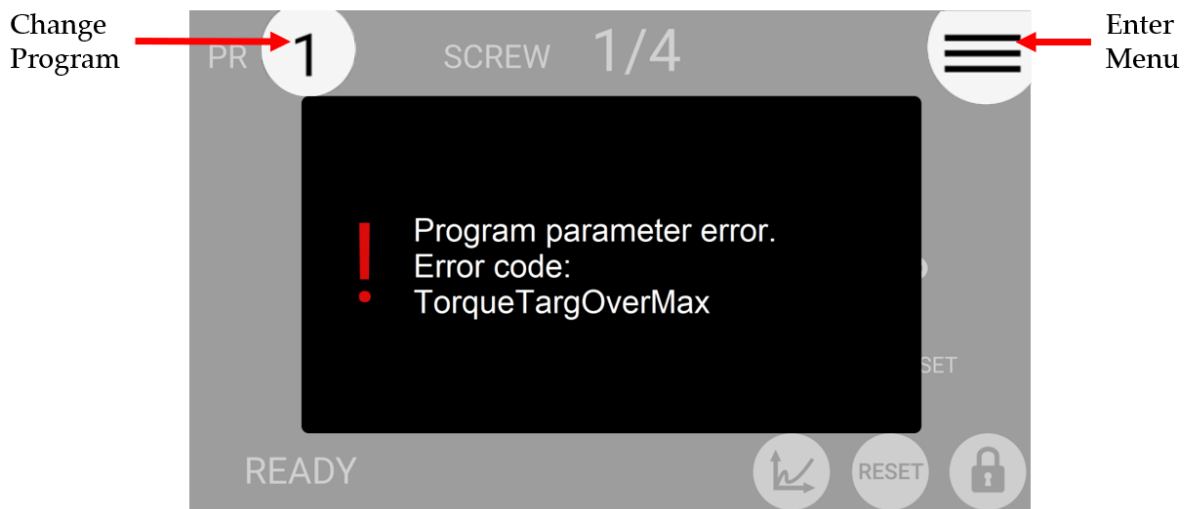

To resolve the error, select a program previously configured for the connected screwdriver model, or enter the main menu to modify the parameter out of range for the current program.

Note: by default, all programs have parameters compatible with screwdriver models up to the KDS-PL15. However, you can use the “[FACTORY RESET](#)” function to reset all programs to parameters compatible with any screwdriver model via the “GENERAL SETTINGS” screen:

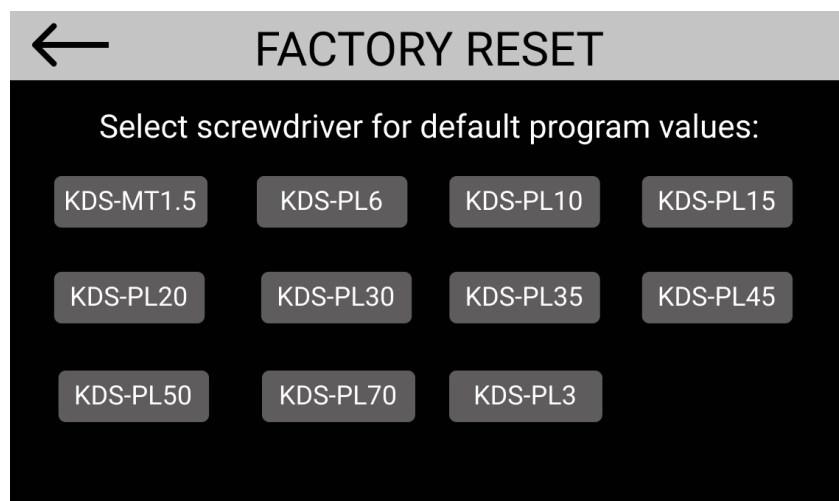

The “Program parameter error” messages can be the following:

TorqueTargOverMax	Target torque higher than the allowed limit for the screwdriver.
SpeedTargOverMax	Target speed higher than the limit allowed for the screwdriver.
SpeedTargUnderMin	Target speed less than the limit allowed for the screwdriver.
DownshiftTorqueOverTarg	The fast phase torque setting is higher than the final target torque.
DownshiftSpeedOverMax	The speed of the fast phase of this program is higher than the maximum allowed by the screwdriver.
DownshiftSpeedUnderMin	The speed of the fast phase of this program is less than the minimum allowed by the screwdriver.
DownshiftSpeedUnderFinalSpeed	The speed of the fast phase is lower than the final speed (slow phase speed).
TorqueMaxOverMaxLim	The Torque Target or Torque Max values are higher than the limit for the connected screwdriver.
TorqueMaxUnderMinLim	In angle control: the maximum torque set in the program is equal or lower than the minimum limit of the screwdriver. In torque control: The maximum torque set in the program is equal or lower than the target torque already set.
TorqueMinOverMaxLim	In angle control: the minimum torque set in the program is equal or higher than the maximum torque already set. In torque control: the minimum torque set in the program is equal or higher than the target torque already set.
RevTorqueOverMax	The reverse torque of this program is higher than the maximum torque of the screwdriver.
RevSpeedOverMax	The reverse speed is higher than the maximum allowed by the screwdriver.
RevSpeedUnderMin	The reverse speed is lower than the minimum allowed by the screwdriver.
RunningTorqueOverMax	In running torque – compensate mode, the sum of the max running torque and the target torque is higher than the maximum torque of the screwdriver. In running torque – monitor mode, the max running torque is higher than the maximum torque of the screwdriver.

If the connection with the screwdriver is successful, the main screen will be displayed, and the screwdriver will be ready for work.

Connect a thumb drive on the USB-A port (the larger USB port) to automatically save each screwdriving result.

TERMINOLOGY

KDU/K-DUCER/control unit: the KDU1 / KDU1A control unit

KDS/screwdriver: the transducerized screwdriving tool to be used with the KDU control unit

Transducer: electronic component installed inside the KDS screwdriver which measures the torque in real time

Tightening: the screwdriving cycle, from start (pressing of the lever or initiating remote lever control), to finish (automatic motor stop or lever or remote lever control release, whichever happens first)

Rundown: the portion of the tightening cycle before reaching the seating point (the point where the screw or bolt head touches the assembly)

Seating point: the point of the tightening at which the head of the fastener touches the assembly, marked by an increase in the torque rate (steeper torque-angle slope) and marking the end of the rundown phase.

Torque: rotational force

Closing torque: the last torque value measured when the screwdriver motor stopped or when the screwdriver lever or remote lever control was released.

PV/Running torque: the peak or average torque value encountered during the rundown phase, before reaching the seating point.

Clamping torque: the closing torque minus the running torque. This is, theoretically, the only portion of the closing torque that generates a clamping force from the fastener.

Target torque: the closing torque that the system will target (torque control mode only), resulting in a "Screw OK" result if successful. In Running Torque – Compensate mode, the system targets a **Clamping torque** equal to the target torque, instead of a closing torque.

Max power phase: an optional phase of the tightening during which the applied torque is allowed to reach the maximum torque achievable by the screwdriver.

Torque control mode: a tightening where the screwdriver motor automatically stops upon reaching the target torque

Angle: the revolutions of the tip of the screwdriver, in degrees. The starting point of the angle measurement depends on the settings chosen.

Target angle: the angle measurement upon which the screwdriver motor will stop (angle control mode only), resulting in an “Angle OK” result if successful

Angle control mode: a tightening where the screwdriver motor automatically stops upon reaching the target angle

Run time: the duration of the tightening, in seconds

Run time mode: a tightening where the screwdriver motor automatically stops at the desired run time

Program/batch: a set of one or more screws sharing the same parameters (torque, angle, speed, barcode, etc)

Program number: the identifier of one of the 200 configurable programs (1 to 200)

Current program: the program currently selected for tightening

Program mode: in this mode, the unit works according the selected program

Sequence/Job: an ordered set of up to 16 programs, with the option to define how to transition between programs

Sequence letter/number: the identifier of one of the 24 configurable sequences (A to X)

Current sequence: the sequence currently selected for tightening

Sequence mode: in this mode, the unit works according to the selected sequence

OK/NOK: the result of the tightening. OK: tightening finished respecting all of the configured parameters. NOK: tightening finished without respecting one or more of the configured parameters.

PV / Running torque mode: an optional phase of the tightening during which the peak or average torque value is measured, and then added to the torque target in real time for the current tightening.

OPERATING THE KDS SCREWDRIVER

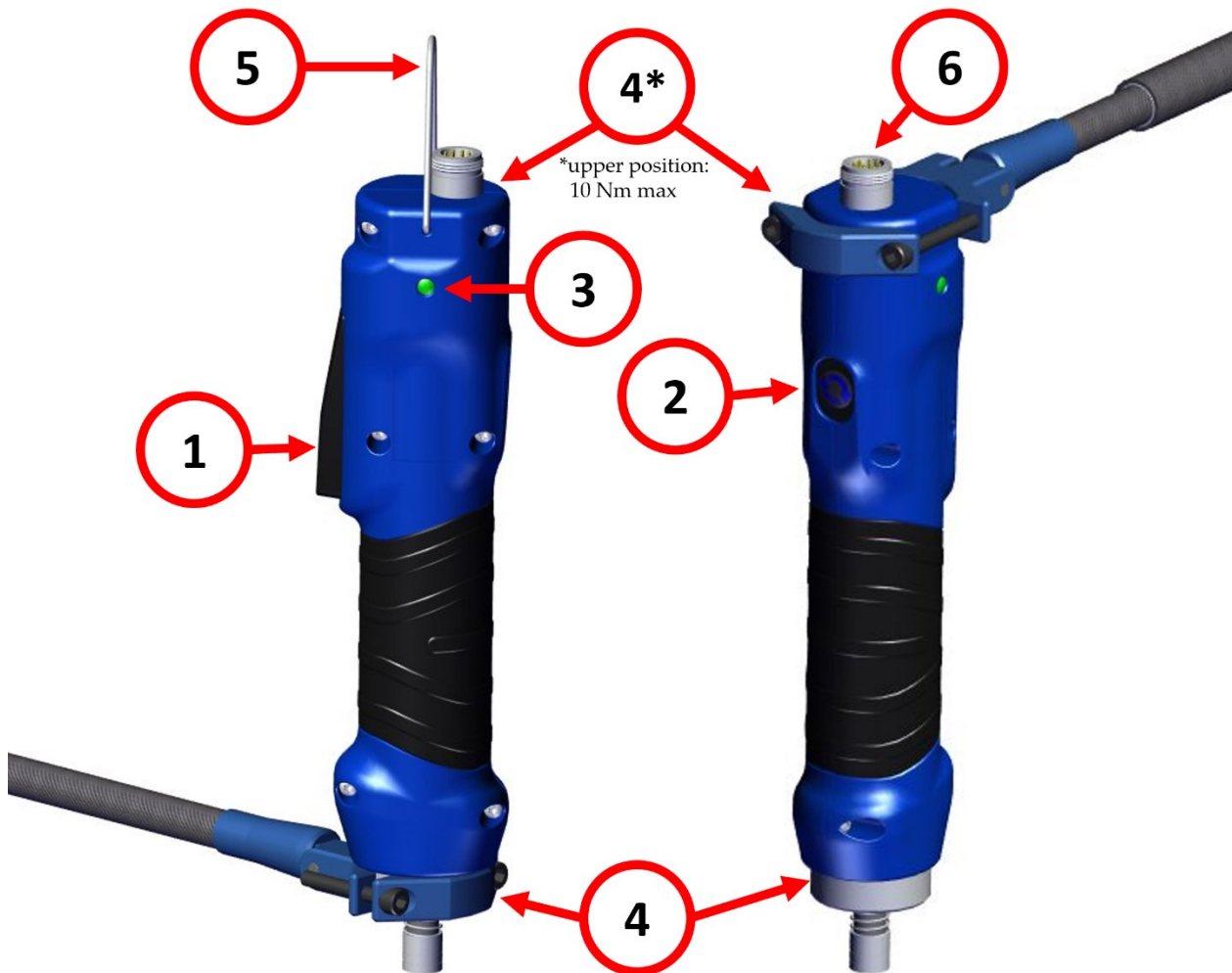

Warning: Kolver strongly recommends using a reaction arm when applying torques greater than 5 Nm. Using KDS screwdrivers sizes 20Nm and above without a reaction arm or with an improperly sized or improperly installed reaction arm may result in severe injury.

(1) Lever

Press and hold the lever to initiate a tightening.

The screwdriver will automatically stop according to the configured program, in either an OK or a NOK state, depending on the success of the tightening.

The screwdriver will also stop if the lever is released in the middle of the tightening, and either return to the READY state or raise the NOK state if the LEVER ERROR option is active for the current program (Programs menu > Other > [LEVER ERROR](#)).

(2) Reverse button / switch

Press and hold the button to reverse, rotating in the opposite direction of the selected direction of rotation for the lever (see Programs menu > Other > [ROTATION](#)).

The behavior of the reverse button can be changed from button to switch, from the general settings menu (General Settings > [REVERSE BUTTON](#)).

(3) LEDs

The two LEDs indicate the state of the screwdriver:

	Blinking white: the screwdriver was just connected to the K-DUCER control unit
	Off: the screwdriver is ready, or the screwdriver is not connected
	Solid green: the last screw result was OK
	Solid red: the last screw result was NOK
	Solid blue: screwdriver is running in the tightening direction, either via the lever or via remote control
	Solid purple: the screwdriver is running in the de-fix direction, either via the reverse button, or via remote control
	Blinking purple: the reverse button is in switch mode and is activated. The screwdriver is ready to run in de-fix rotation via the main lever.

(4) Reaction arm connections

Fix the reaction arm to one these areas only, and never anywhere else on the screwdriver. The upper fixing position is only allowed for torque targets lower than 10 Nm. Refer to [Installation of torque reaction arm](#)

(5) Hanging hook

To hang the screwdriver somewhere easily accessible in the operator's workbench.

(6) Female connector

To connect the screwdriver to the K-DUCER control unit

Pistol models: the reverse button and status LED are on the back of the screwdriver:



OPERATING THE K-DUCER CONTROL UNIT

Main Screen – Program Mode – navigation tree

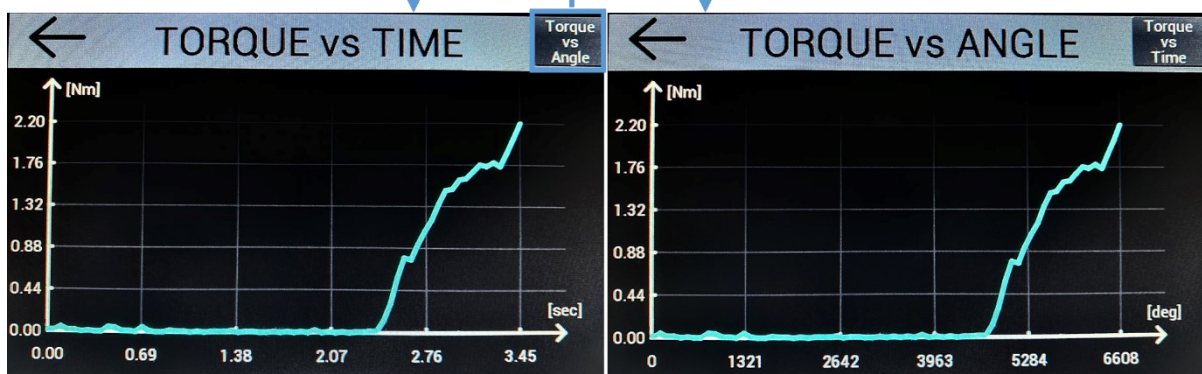
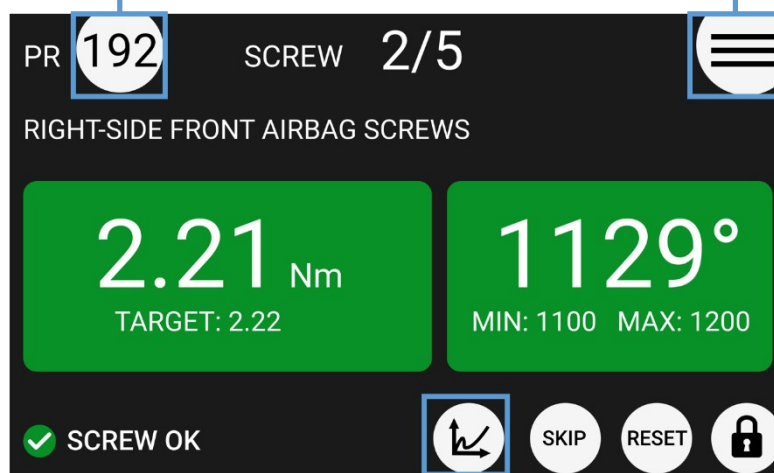
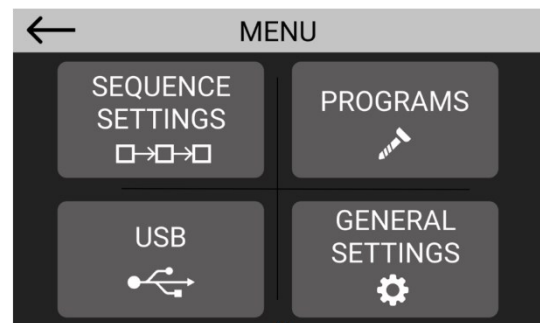
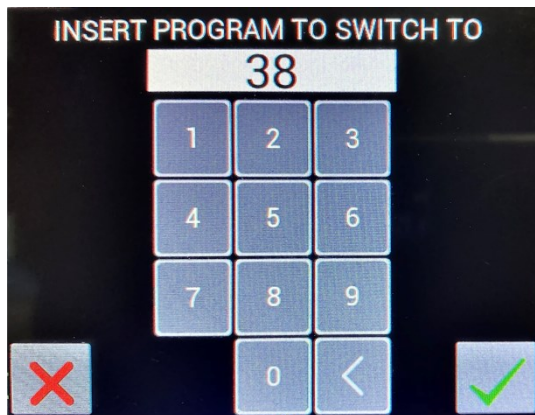

(see [Torque and Angle graphing](#) for more information)

Main Screen – Program Mode

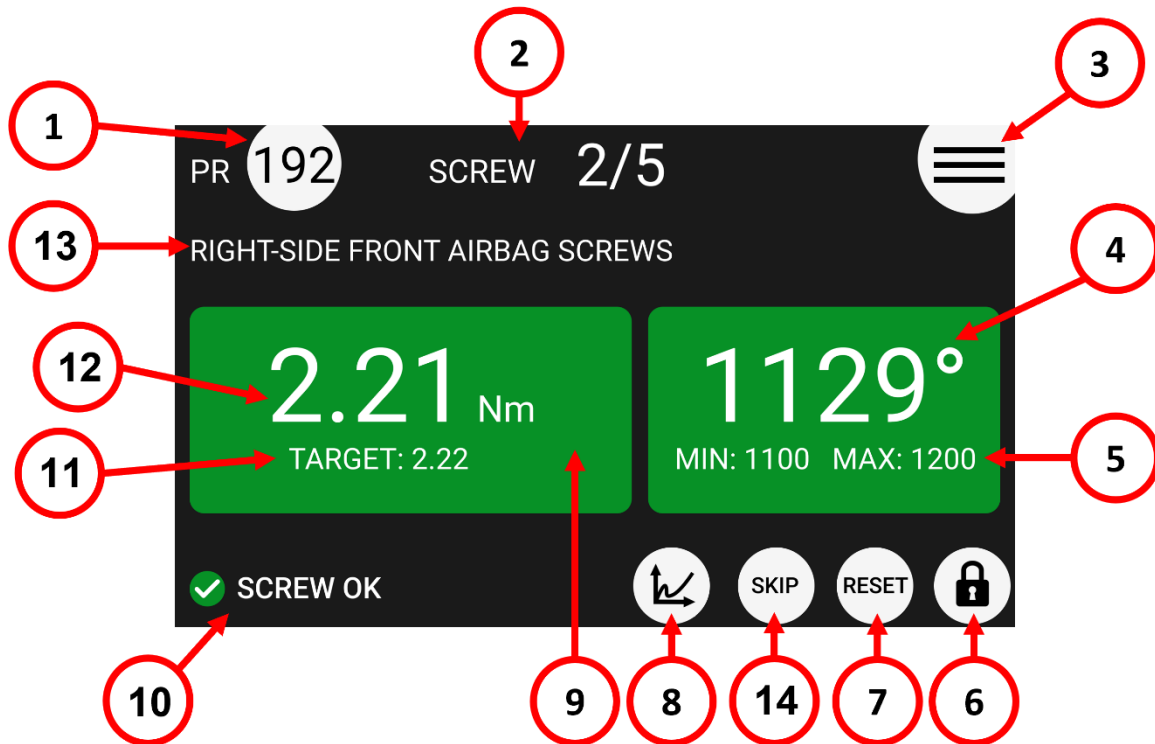

(1) Program (“PR”) number currently selected

Touch to select a different program (1 through 200).

(2) Screw count

Counter: screws successfully completed / number of screws in current program

Note: does not appear if NUMBER OF SCREWS parameter is set to zero. Number of screws is also referred to as “batch size” in the industry.

(3) Main Menu Button (≡)

Tap to enter the main menu

(4) Angle value

Measured angle value for last screw, in degrees.

(5) Angle target / bounds

Shows the target angle when in angle control mode, or the min/max angle bounds when in torque control mode or timed tightening mode, for the current program, in degrees.

(6) Menu lock status

White background means no password is required to access the configuration menu.

Red background means the configuration menu is password protected.

(7) Reset (“RST”) button

Screw/Program/Sequence Reset (“RST”) button. Presence and function of this button depend on the corresponding settings in the GENERAL SETTINGS menu.

- (8) Torque charts**
Tap to display the Torque-time and torque-angle charts for last screw. Refer to [Torque and Angle graphing](#) for usage.
- (9) Torque measurement unit**
You can select a different unit from the GENERAL SETTINGS menu.
- (10) Status bar**
Shows the last screw result or error messages (ready, screw OK, screw NOK, errors).
- (11) Torque target / bounds**
Shows the target torque when in torque control mode, or the min/max torque bounds when in angle control mode or timed tightening mode, for the current program.
- (12) Torque value**
Measured torque value applied to the last screw.
- (13) Program description**
Shows the description for the current program. You can enter a description for the current program via Programs Menu > Other > [DESCRIPTION](#).
- (14) Skip button**
Screw skip button, tap to increase the screw count by 1. Presence and function of this button depend on the corresponding settings in the GENERAL SETTINGS menu.

Main Screen – Sequence Mode – navigation tree



(see [Torque and Angle graphing](#) for more information)

Main Screen – Sequence Mode

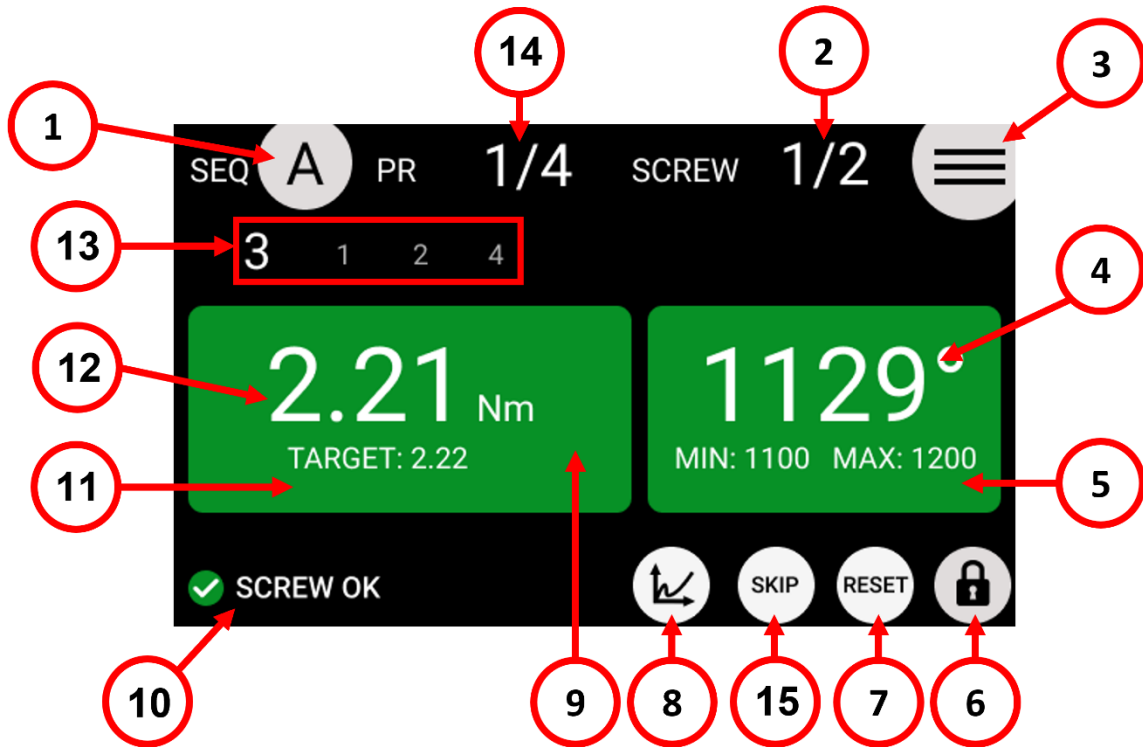

(1) Sequence (“SEQ”) currently selected

Touch to select a different sequence (A through X).

(2) Screw count

Counter: screws successfully completed / number of screws in current program

Note: does not appear if NUMBER OF SCREWS parameter is set to zero. Number of screws is also referred to as “batch size” in the industry.

(3) Main Menu Button (≡)

Tap to enter the main menu

(4) Angle value

Measured angle value for last screw, in degrees.

(5) Angle target / bounds

Shows the target angle when in angle control mode, or the min/max angle bounds when in torque control mode or timed tightening mode, for the current program, in degrees.

(6) Menu lock status

White background means no password is required to access the configuration menu.

Red background means the configuration menu is password protected.

(7) Reset (“RST”) button

Screw/Program/Sequence Reset (“RST”) button. Presence and function of this button depend on the corresponding settings in the GENERAL SETTINGS menu.

- (8) Torque charts**
Tap to display the Torque-time and torque-angle charts for last screw. Refer to [Torque and Angle graphing](#) for usage.
- (9) Torque measurement unit**
You can select a different unit from the GENERAL SETTINGS menu.
- (10) Status bar**
Shows the last screw result or error messages (ready, screw OK, screw NOK, errors).
- (11) Torque target / bounds**
Shows the target torque when in torque control mode, or the min/max torque bounds when in angle control mode or timed tightening mode, for the current program.
- (12) Torque value**
Measured torque value applied to the last screw.
- (13) Current and next program numbers in sequence**
Shows the current program loaded in the sequence in larger font, and the following program numbers in the sequence.
- (14) Program count**
Counter: programs successfully completed / number of programs in current sequence
- (15) Skip button**
Screw skip button, tap to increase the screw count by 1. Presence and function of this button depend on the corresponding settings in the GENERAL SETTINGS menu.

Torque and Angle graphing

The K-DUCER offers a powerful torque and angle graphing functionality, which can be used to study the characteristics of your fastening joint and optimize the [PROGRAMS menu](#) settings to maximize precision while minimizing assembly cycle time.

The Torque and Angle graphing data for each tightening is also saved with the screwdriving results, refer to the [Retrieving and storing the screwdriving results](#) section. You can also store and visualize the graphs using the free K-Graph software. See [FREE K-EXPAND, K-LINK, AND K-GRAPH SOFTWARE](#).

Visualizing the Torque and Angle charts

To open the Torque and Angle graph screen, simply tap the graph icon on the bottom right of the screen, after a tightening.

To switch between the “Torque vs Time” and the “Torque vs Angle” graph, tap on the button on the top right of the graph screen.

You can only visualize the graph corresponding to the last tightening, however, the torque and angle graphing for each tightening can be automatically stored to a USB drive or to a networked PC as described in the [Retrieving and storing the screwdriving results](#) section.



Interpreting the Torque and Angle charts

The “Torque vs Time” graph shows the torque measured by the screwdriver starting from the moment the lever is pressed (or a remote-lever command is received) up to the moment the tightening finishes correctly in an error condition (such as “Torque Over Max”).

The Y-Axis represents the torque data, in the [MEASUREMENT UNITS](#) selected. The X-Axis represents the time, in seconds, or, in the case of the Torque vs Angle chart, the **angle of revolution**, in degrees, always starting from the moment that the lever is pressed and ending at the moment the tightening finished.

The maximum Y-Axis tick shown on the Y-Axis always corresponds to the **maximum torque** measured during the tightening. In those situations where the **maximum torque** is not equal to the **final torque**, the **final torque** value will be annotated next to the final point of the torque graph.

When the Angle Count [STARTING AT](#) setting is set to “Ext” or to a non-zero Torque Threshold, the torque graph will change color and the **torque** value at which the angle count was triggered will be displayed on the screen.



The graphs illustrated here were produced with a KDS-PL6/ESD screwdriver running on Kolver joint simulator (part number 240600) arranged in the semi-elastic configuration. We supplied additional hand-resistance to generate the “starting at” threshold.

Torque and Angle charts with Prevailing / Running Torque

When utilizing the [PV / RUNNING TORQUE](#) feature, the graph will highlight the Running Torque [WINDOW](#) in purple.

The average or peak running torque value will also be displayed on the screen, depending on the selected setting.

The total torque value will be highlighted on the graph, next to the final point of the torque trace, and the “clamping torque” will be displayed in green (for OK results) or in red (for NOK results) as well.

The “clamping torque” in this case refers to the total torque minus the running torque value.

When the Angle Count [STARTING AT](#) setting is set to “Ext” or to a non-zero Torque Threshold, the torque graph will change color and the **torque** value at which the angle count was triggered will be displayed on the screen.



The graphs illustrated here were produced with a KDS-PL6/ESD screwdriver running on Kolver joint simulator (part number 240600) arranged in the semi-elastic configuration. We supplied additional hand-resistance to generate a non-zero “running torque” value and “starting at” threshold for illustration purposes.

Generating the Torque and Angle graphs from CSV data

The easiest way to visualize the graphs saved in CSV format by the KDU controller on the USB drive, is to open the file using the free K-Graph software available at kolver.com. Simply open the CSV file via the “File” menu on the program:

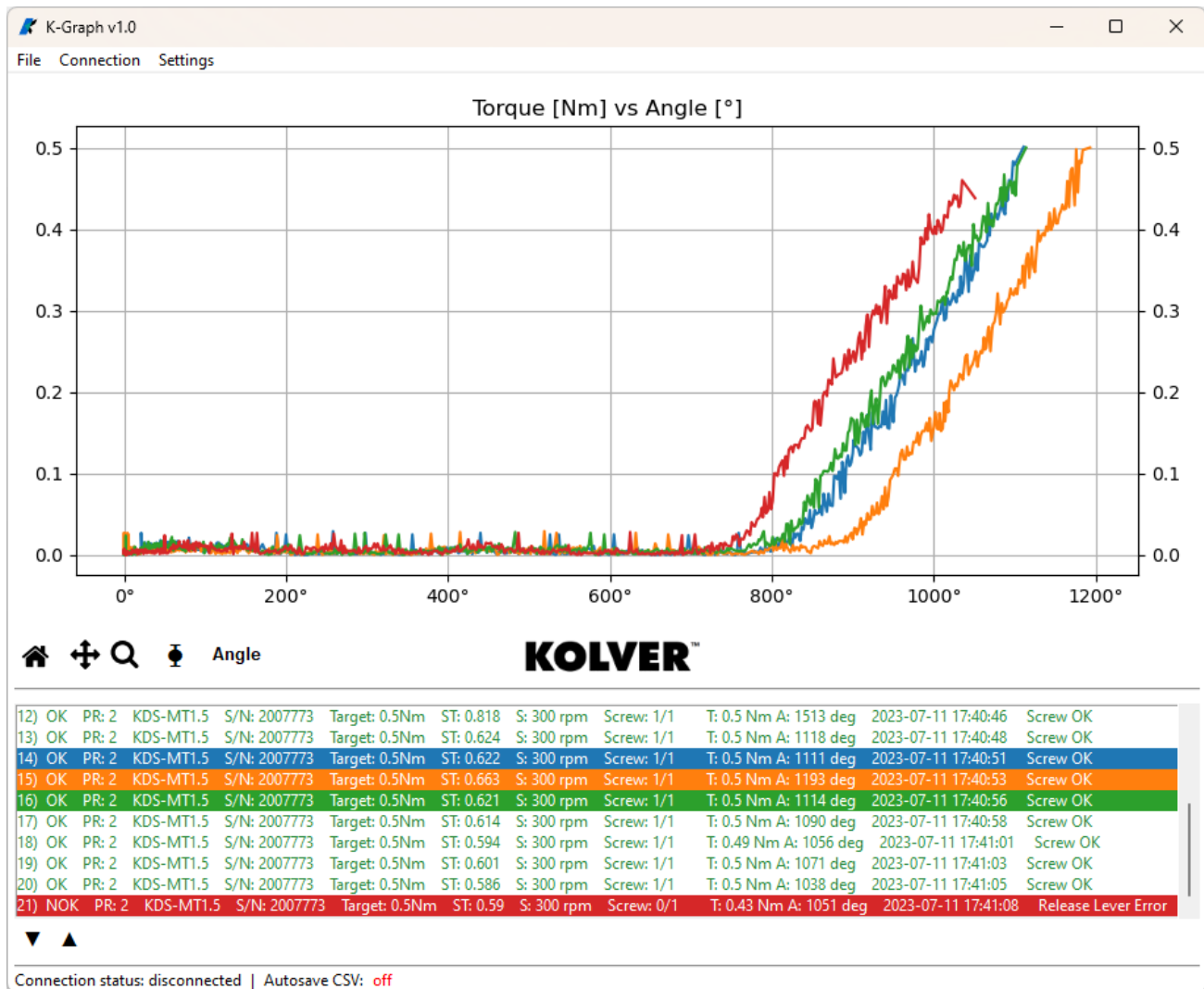

To create the graphs in Excel or other spreadsheet program:

Open the CSV file. Each tightening result is split into three lines: the result line, which is matched to the header fields on the first row; the angle graph series line, and the torque graph series line.

The first column of each line indicates the contents of that line. The second column indicates the **Tightening ID**, which will be identical for the three lines comprising a single result. On the angle chart and torque chart lines, the actual data series begins on column 3. Each data point is equally spaced in time and is aligned for the angle/torque series. The time interval is indicated on the **Results** line, column **AK** and **AM**, and is typically 1ms. In columns **AJ** and **AL** of the **Results** line you can find the measurement units for the angle and torque graph series.

Determining the joint type

Understanding the characteristics of your joint type is critical to maximize the precision of the K-DUCER system, minimize the wear-and-tear on the tool, and minimize the assembly cycle time for your application.

According to the ISO standard 205393:2017, the types of joints found in practice will fall in between these two “extreme” definitions:

1. Soft, elastic, low torque-rate joint: after the fastener is seated, the tightening reaches its target torque in more than one full revolution ($> 360^\circ$).
Examples: plastic screws; fasteners with split washers; self-threading fasteners.
2. Hard joint, inelastic joint, or high torque-rate joint: after the fastener is seated, the tightening reaches its target torque in a fraction of a revolution ($< 30^\circ$).
Examples: metal screws on metal socket with simple washer.

Seating indicates the point at which the underside of the screw or bolt **head** touches the socket, after the rundown phase.

A simple approach to determine the joint type is to perform a tightening of your fastener with the K-DUCER and observe the slope of the Torque vs Time graph.

A soft joint will show a moderate slope from the seating point to the final torque, while a hard joint will show a very high slope (almost vertical).

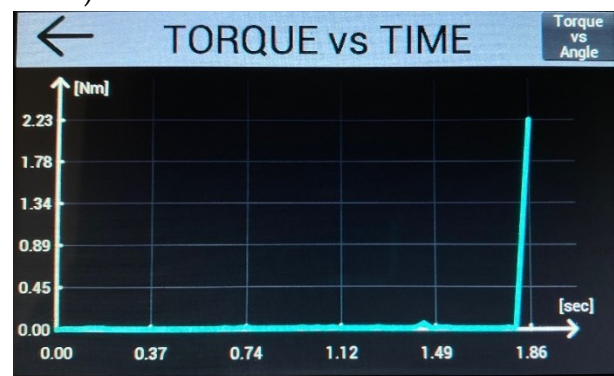
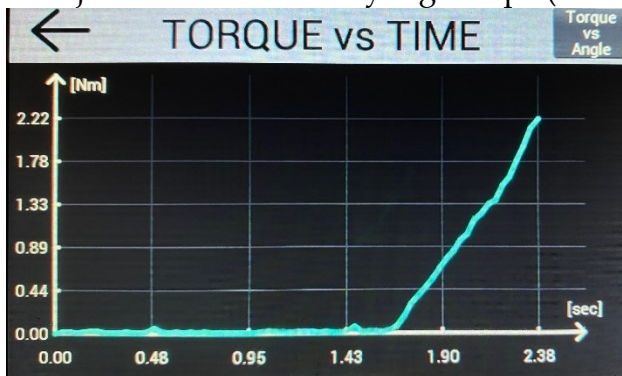

Left picture: Torque vs Time graph for a soft joint, generated using a KDS-PL6/ESD on Kolver joint simulator 240600.

Right picture: Torque vs Time graph for a hard joint, generated using a KDS-PL6/ESD on a metal screw with non-locking washer on a threaded metal socket.

The K-Ducer system will add a warning below the status bar if it is not able to stop at the target torque within the 5% guaranteed limits due to tightening on a hard joint with

suboptimal tightening parameters. When tapping on the warning, a popup will appear suggesting to review the chapter [Determining the appropriate program settings](#).

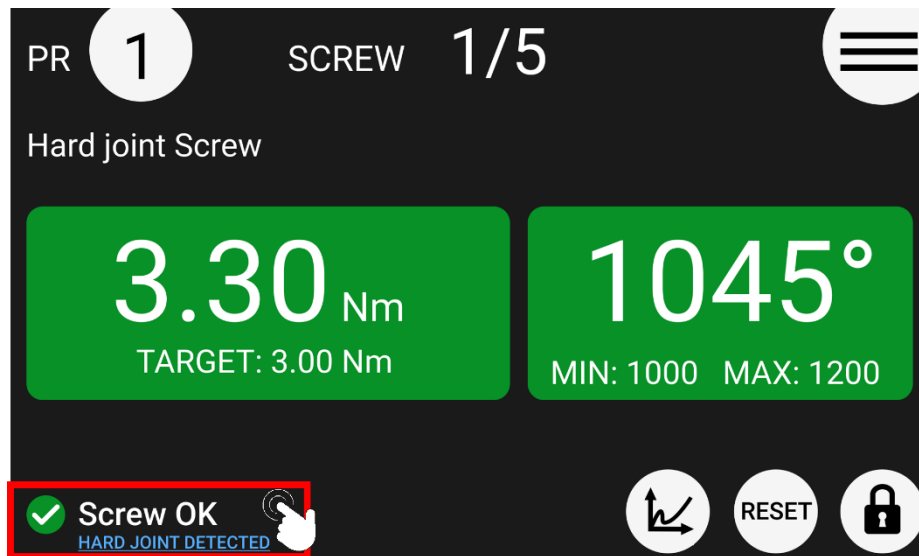

Determining the appropriate program settings

The K-DUCER is a highly accurate system, but it is critically important to select the appropriate settings to ensure that the desired torque is correctly applied, and that the screwdriver motor works effectively and efficiently.

Determining the appropriate program settings for your application requires careful consideration and is ideally done by a trained engineer with knowledge of the torque specifications and of the mechanical characteristics of the assembly joint.

Please take advantage of the free support provided by your Kolver representative throughout this process.

What follows are some general guidelines, but they are not meant to substitute a careful examination of the application. Each application is unique and may require deviations from these guidelines.

These guidelines are always superseded by the specifications of the assembly joint and by all safety requirements of the operator and work environment.

Kolver is not responsible for damages or injuries resulting from following these guidelines.

Hard/inelastic joints

These joints are best finished at low speed, to improve precision and avoid a high velocity impact at the end of the tightening.

Choose a low [FINAL SPEED](#) such as 100 RPM*, and if desired, use a two-speed approach by activating the [DOWNSHIFT](#) setting using either an angle threshold or a torque threshold equal to 20-50% of the target torque.

The lower the torque target is relative to the range of the screwdriver, the higher the effect of motor inertia will be, requiring a lower DOWNSHIFT speed to avoid overshooting the downshift threshold through and past the final torque target.

Soft/elastic joints

These joints are best executed at high speed, to avoid exposing the motor to a prolonged time-under-tension and [overheating the tool](#).

Choose a higher [FINAL SPEED](#) for these joints, and if a two speed approach is required, activate the [DOWNSHIFT](#) setting using either an angle threshold or a torque threshold of at least 80% of the target torque to ensure most of the torque is applied at higher speed.

Very elastic joints, or semi-elastic joints with a high target torque relative to the range of the screwdriver, may benefit from a higher [FINAL SPEED](#) and from avoiding the use of the [DOWNSHIFT](#) function altogether.

*for KDS-PL15 and smaller high-speed drivers. Use a lower speed for higher torque tools.

Screwdriving Phases

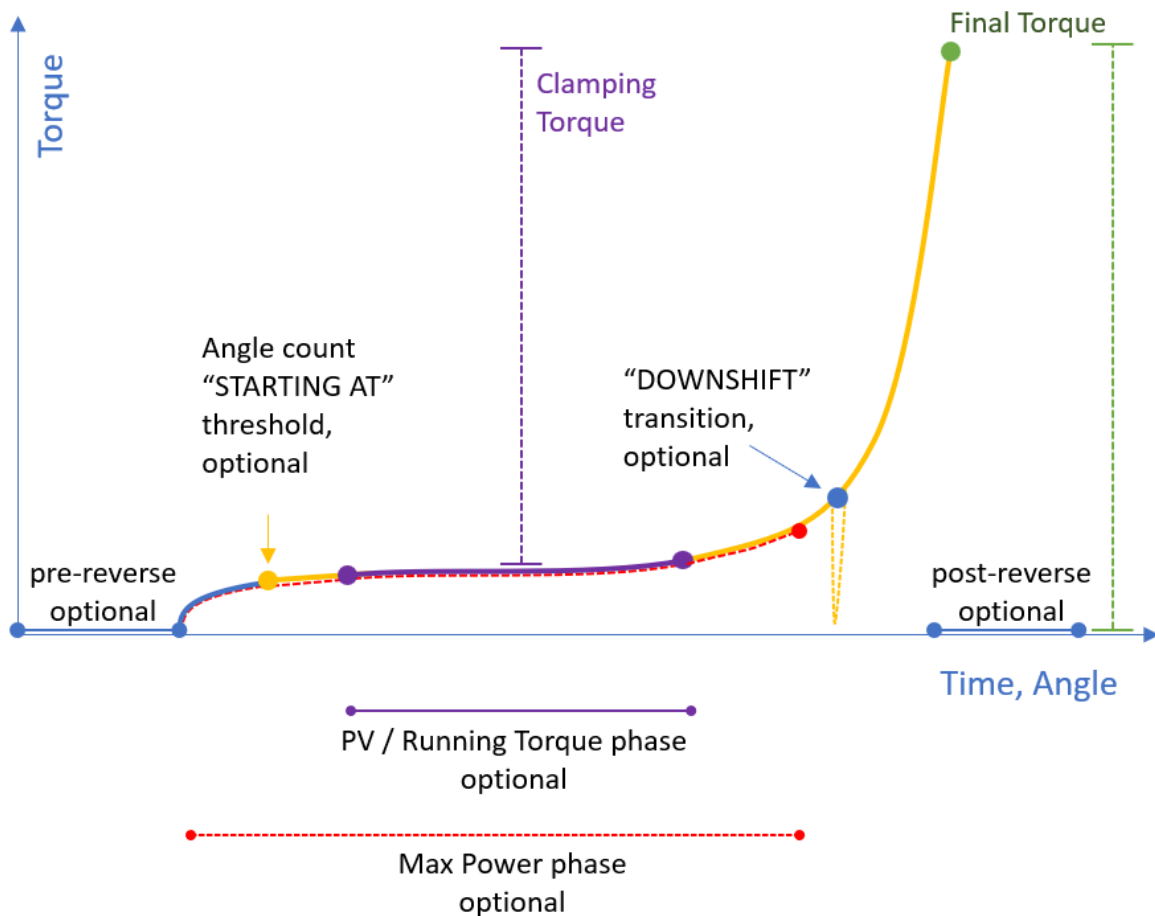

● All colored circles in the diagram above represent configurable targets or thresholds.

Phase	Speed	Halting Torque	Halting Angle
Pre-reverse	Reverse speed	Reverse Torque	Pre-reverse setting
Max Power	Tightening speed*	Highest torque achievable by KDS screwdriver	Max angle (TC) Target angle (AC)
PV / Running Torque	Tightening speed*	Running torque max limit	Max angle (TC) Target angle (AC)
Tightening	Tightening speed*	Target torque** (TC) Max torque (AC)	Max angle (TC) Target angle (AC)
Post-reverse	Reverse speed	Reverse Torque	Post-reverse setting

TC = Torque Control Mode (i.e., Torque Targeting Mode)

AC = Angle Control Mode (i.e., Angle Targeting Mode)

* the tightening speed is equal to the [FINAL SPEED](#) after the Downshift threshold or if the [DOWNSHIFT](#) function is OFF, otherwise it is equal the DOWNSHIFT RPM setting

** plus the running torque value, if Running Torque Compensate mode is enabled

Retrieving and storing the screwdriving results

There are several ways to store and retrieve the results and torque/angle graphs of each tightening:

Via MODBUS TCP or Open Protocol (CN5)

Refer to the [MODBUS TCP](#) section. Kolver also provides ready-to-use Python, C#, and PowerShell scripts to retrieve and save the screwdriving results that can be run on a PC computer or server, included in the [MODBUS TCP code examples and literature](#) packet.

Via free Kolver software (mini-USB or ethernet CN5)

Refer to the [FREE K-EXPAND, K-LINK, AND K-GRAPH SOFTWARE](#) section.

On USB flash drive (USB-A)

Simply connect a FAT32-formatted USB drive on the USB-A connector. The K-DUCER will create a folder named as the serial number of the connected screwdriver.

Inside this folder, the K-DUCER will save the results of each tightening inside a CSV or TXT file (see [RESULTS FORMAT](#) setting). The name of the file will be the date (YYMMDD) of the first tightening contained, and a new file will be created for each day.

Use the free K-Graph software to visualize the CSV results ([FREE K-EXPAND, K-LINK, AND K-GRAPH SOFTWARE](#)).

Via serial printer or serial terminal (CN2 or CN4)

You can connect to CN2/CN4 with a serial printer (for example Kolver model PRNTR1) or with any serial terminals, for example Hyper Terminal, Realterm, or K-Expand for PC, to print the results of each tightening.

The print string is transmitted at the end of each tightening if the [SERIAL PRINT](#) setting is enabled for the active tightening program. The serial connection parameters must be:

RS232 – 9600 baud – 8 data bits – 1 stop bit – no parity

Data format for the screwdriving results

With the [RESULTS FORMAT](#) option set to “CSV” (recommended), the print string contains the following data:

Section	Description
Row contents	Row contents. Results, Angle Chart, or Torque Chart
Tightening ID	A number to identify matching Results, Angle Chart, and Torque Chart rows associated with the same result.
Barcode	Printout of the scanned barcode. In dual barcode modes, only the serial number barcode is printed.
Result	OK or NOK depending if tightening completed respecting the configured parameters
Program	The program number used for the tightening
Program Description	The program description
Model	The screwdriver model used for the tightening
Serial Nr	The serial number of the screwdriver
Target	The target torque or angle value
Target units	The measurement units of the target value
Duration	The duration of the tightening in seconds
Final Speed	The closing speed of the tightening
OK Screw count	Number of successfully tightened screws inclusive of the last one. Does not increment for NOK screw results.
Number of screws	Total number of screws in program
Sequence	Current sequence
Seq. program index	Positional index of the current program within the sequence (1 to 16)
Seq. program qty	Total number of programs within the current sequence (1 to 16)
Torque result	Final torque of the tightening. Note: with "running torque", this value corresponds to the "clamping torque", and not to the total final torque.
Peak Torque	The maximum torque measured at any point during the tightening
Running Torque Mode	0 = Off, 1 = Time Window with Average Value, 2 = Time Window with Peak Value, 3 = Angle Window with Average Value, 4 = Angle Window with Peak Value. 5-8: same as 1-4, for Monitoring mode.
Running Torque	Average or peak running torque value calculated during the tightening
Total torque	Final total torque. For tightening with running torque mode on, this equals the "final torque" ("clamping torque") value plus the calculated "running torque" value.
Angle result	Final angle of the tightening, in accordance with the "angle start at" setting.
Angle start at mode	0 = Lever, 1 = External Input, 2 = Torque Threshold
Angle start at torque target	Torque target for "Angle start at mode" = 2

Angle start at angle value	Rotational angle, starting from the moment the lever was pressed, at which the angle count started, for "Angle start at mode" = 1 or = 2
Downshift Mode	0 = Off, 1 = Torque Threshold, 2 = Angle Threshold
Downshift Speed	Initial speed of the tightening (rundown speed)
Downshift Threshold	Torque or angle threshold, for "Downshift Mode" = 1 or = 2
Torque Units	The measurement units for all torque values reported
Angle Units	The measurement units for all angle values reported
Speed Units	The measurement units for all speed values reported
Time Units	The measurement units for all time values reported
Date-time	Date and time at which the tightening ended
Notes or Errors	Notes such as "PROGRAM END" for OK results, or error details such as "Err Angle Max" for NOK results
Angle chart units	Measurement units of the "angle chart" row/data
Angle chart x-interval ms	Time interval between consecutive points of the "angle chart" data, normally 1ms and identical to that of "torque chart"
Torque chart units	Measurement units of the "torque chart" row/data
Torque chart x-interval ms	Time interval between consecutive points of the "torque chart" data, normally 1ms and identical to that of "angle chart"

With the [RESULTS FORMAT](#) option set to "TXT" (legacy setting), the print string contains the following data:

Section	Description	Example
Barcode	Printout of the scanned barcode. In dual barcode modes, only the serial number barcode is printed.	BC: 7612320103052
Result	OK or NOK depending if tightening completed respecting the configured parameters	OK
Program	The program number used for the tightening	PR: 8
Model	The screwdriver model used for the tightening	KDS-PL10
Serial Nr	The serial number of the screwdriver	s/n: 1814914
Target	The target torque or angle	TARGET: 2.0Nm
Screw Time	The duration of the tightening in seconds	ST: 1.23
Speed	The closing speed of the tightening	S: 600rpm
Screw count	Number of <i>successfully</i> tightened screws / total number of screws in program	Screw: 1/8
Sequence	Current sequence and program within sequence (program is positional: current/total)	Seq: 1/3
Torque	Final torque of the tightening	T: 1.99Nm

Angle	Final angle of the tightening	A: 114deg
Date-time	Date time of the tightening	18/01/18 17.44.50
Notes or Errors	Notes such as "PROGRAM END" for OK results, or error details such as "Err Angle Max" for NOK results	PROGRAM END, <i>or</i> Err Angle Max

For example:

BC: 7612320103052 OK PR: 8 KDS-PL10 s/n: 1814914 TARGET: 2.0Nm ST: 1.23 S:600rpm Screw:1/8 Seq: A 1/1 T: 1.99Nm A: 114deg 18/01/18 17.44.50

NOK PR:26 KDS-MT1.5 s/n: 1964211 TARGET:10.00lbf.in ST: 10.166 S:300rpm Screw:0/7 Seq:1/1 T: 0.00lbf.in A: 20008deg 20/02/30 11.33.10 Err Angle Max

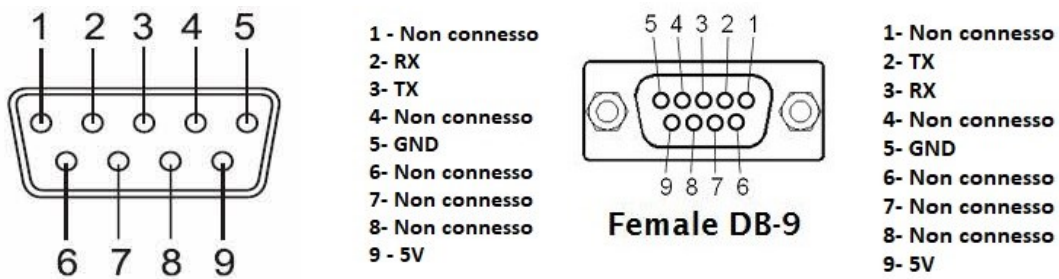

PIN	NAME	FUNCTION
2	RX	RS232 reception.
3	TX	RS232 transmission.
5	GND	Common to every input. Signals have to be enabled making contact between the desired signal and this pin (GND).
9	+5V	Not used

Connecting a barcode scanner

The K-DUCER is compatible with RS-232 capable barcode scanners such as Kolver P/N 020050 (1D barcode scanner) and 020051 (2D barcode scanner).

It is also possible to connect a USB barcode scanner by purchasing the Kolver USB-to-RS232 adapter P/N 010415.

Any barcode type supported by the scanner will work with the K-DUCER, but the total length of each barcode must be 16 characters or less for PROGRAM and SEQUENCE barcodes, or 63 characters or less for SERIAL NUMBER barcodes.

:

Connect the barcode scanner to the CN2 9-pin male serial connector. If using a 2D barcode scanner such as Kolver P/N 020051, or the USB-to-RS232 adapter, you must also connect the included external power supply.

Serial barcode scanners should be configured with the following serial connection parameters:

RS232 – 9600 baud – 8 data bits – 1 stop bit – no parity

For Kolver P/N 020051, this is done by scanning the included configuration barcode.

For other scanners, refer to their user manual.

With Kolver P/N 010415, the settings are applied automatically.

Note: a SERIAL NUMBER barcode can also be transmitted via ethernet port through MODBUS TCP and OPEN PROTOCOL.

Once connected, select one of the five barcode modes to work with: see [BARCODE MODE](#).

Connecting a bit-tray or switchbox (CBS880, SWBX88)

To utilize the accessories SWBX88 (switchbox) and CBS880 (socket tray) you'll need the M-F serial cable (code 881007) and the KIT KDU ADAPTER WITH SW AND CBS (code 010410). Connect and secure the adapter to the accessory, then the M-F 9-pin cable from the adapter to the CN4 connector on the K-DUCER:



The working mode of these accessories depends on the combination of the following settings:

[SEQUENCE toggle](#) - [SWBX88/CBS880](#) - [REMOTE PR](#) - [REMOTE SEQ](#)

as illustrated in the following table:

Program Mode (SEQUENCE toggle set to: OFF)		
	SWBX88/CBS880 set to: On Prog *	
REMOTE PR set to: SWBX/CBS	The bit lifted from the accessory (1-8) determines the program (1-200) selected on the controller. *	
REMOTE PR set to: any other setting	The program selected (1-200) on the controller determines the bit (1-8) that must be lifted on the SWBX/CBS accessory. (* and **)	
Sequence Mode (SEQUENCE toggle set to: ON)		
	SWBX88/CBS880 set to: On Prog *	SWBX88/CBS880 set to: On Seq
REMOTE SEQ set to: SWBX/CBS	N/A (combination not available)	The bit lifted from the accessory (1-8) determines the sequence (A-X) selected on the controller.
REMOTE SEQ set to: any other setting	The current program within the selected sequence determines the bit that must be lifted on the SWBX/CBS accessory. (* and **)	The sequence selected (A-X) on the controller determines the bit (1-8) that must be lifted on the SWBX/CBS accessory. **

* because the KDU controller supports up to 200 programs and the SWBX/CBS accessories only have 8 slots, when using the [SWBX88/CBS880](#) setting On Prog , you must register the desired SWBX/CBS slot(s) 1-8 to the desired program(s) 1-200 from the Programs > Other > [SWBX88/CBS880](#) setting. If no bit is registered for the current program, the controller will remain locked and display an error message until all bits are returned to the tray.

** The corresponding LED on the accessory will flash until the bit is lifted. The controller will remain locked and display an error message until only the correct is lifted.

If at any time: no bits are lifted, or more than one bit is lifted, or if REMOTE PR/SEQ is set to SWBX/CBS and an incorrect bit is lifted, the controller will remain locked.

Note: if you use less than 8 sockets with the CBS880 accessory, it is recommended to physically disable the unused sockets by turning off the corresponding DIP switches inside the CBS880 accessory, shown in the picture below. Refer to the CBS880 product manual for more information.

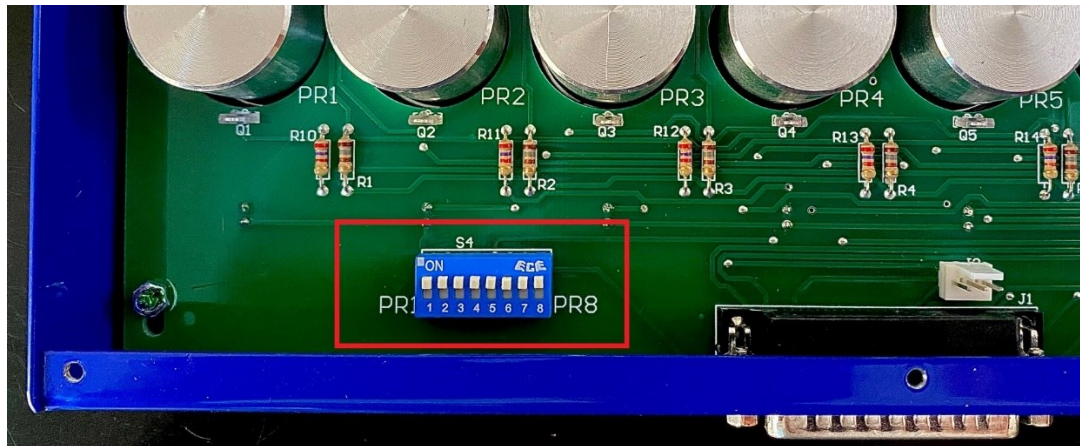

Connecting a K-TLS smart positioning arm

To connect the K-TLS smart positioning arm system to the K-DUCER controller, follow the steps below:

- Connect the arm sensor cable to the ARM port on the K-TLS
- Connect the K-TLS cable to the CN2 or CN4 port on the KDU-1A controller
 - The K-TLS can be connected to either CN2 or CN4
 - The supplied cable connects to CN2 and is a M-F straight DB9 cable
 - Use a M-M null modem adapter to connect the K-TLS to CN4
- Connect the provided 24VDC power supply to the K-TLS adapter
- In the K-DUCER General Settings menu, scroll down to page 7, and select the K-TLS arm model on the K-TLS ARM MODEL 1 parameter
- If you are using a dual K-TLS system with two screwdrivers via the Dock-05 accessory, also select the K-TLS ARM MODEL 2 for the secondary arm
- On the “Program => Other” menu, scroll to Page 3 and enable the K-TLS parameter
- Choose the position tolerances and tap “SET SCREW POSITIONS” to enter the screw positions configuration screen

Refer to [K-TLS ARM](#) for more details on the usage of each option.

CONFIGURING THE K-DUCER

ADVANCED TORQUE CONTROL STRATEGIES

Certain applications may require the use of tightening strategies more advanced than target torque or angle control.

For these applications, the K-DUCER offers Sequential Torque and Angle Control, PV / Running Torque (Compensate and Monitor), Max Power Phase, and multi-step program options. These terms are defined in the [TERMINOLOGY](#) section.

These strategies are disabled by default, and if your application does not require them, you may skip this section.

SEQUENTIAL TORQUE AND ANGLE CONTROL

Note: please familiarize yourself with the “Torque Control and Angle Monitoring” and “Angle Control and Torque Monitoring” ([TORQUE & ANGLE menu](#)) before embarking on this section.

Sequential Torque and Angle Control is a strategy where, as part of a single tightening, the screwdriver first targets a torque, and, after reaching it, rotates for a specified number of degrees (target angle).

For example, you can program the driver to tighten to 20 lbf-in, and then rotate for an additional 180° degrees, all seamlessly and as part of the same program.

To do this, in the ([TORQUE & ANGLE menu](#)):

- set the [ANGLE CONTROL / TORQUE MONITORING flag](#) to “Angle Control and Torque Monitoring”
- set the [TARGET Angle](#) to the number of degrees to rotate for **after** reaching the threshold torque. Set the Min/Max angle error bounds accordingly, if desired.
- set the Torque Min/Max error bounds, if desired. These will be the error bounds on the torque value reached at the very end of the tightening, **after** the target angle has been reached. The final torque will typically be higher than the initial torque target.
- set the [STARTING AT](#) parameter to the Torque value that you want to target for the first phase of the rundown, **before** switching to the angle targeting mode

Make sure to follow the [Determining the appropriate program settings](#) guidance, adding a downshift threshold if necessary. This is especially important for low target torque values (relative to the range of the tool) and/or hard joints!

PREVAILING TORQUE / RUNNING TORQUE (PVT/RT)

Use Prevailing Torque / Running torque **Compensate** mode to apply the **clamping torque**, letting the **closing torque** vary according to the **Prevailing / Running torque** encountered and measured during the Prevailing / Running torque window.

The goal in this case is to apply a consistent amount of clamping force on the assembly, as opposed to a consistent amount of **closing torque**.

You can also choose to measure and monitor the **Prevailing / Running and clamping torques** without affecting the **closing torque**, via the Prevailing / Running Torque **Monitoring** mode. This is useful, for example, to [detect crossthreading](#).

Seating point determination

First, it is necessary to understand the morphology and torque rate of the joint. Perform a series of at least 10 tightening with a target torque near the maximum closing torque allowed by the application (inclusive of Prevailing / Running torque), without using any Prevailing / Running torque, prevailing torque, or downshift settings. Follow all precautions necessary and note that this may damage the assembly.

Note down the following information from torque and angle graphs and/or graph data provided by the K-DUCER. You can also take advantage of the free K-Expand software to readily analyze the graphs point-by-point.

- Seating point, in terms of both torque and angle, and of their variability
- Prevailing / Running torque

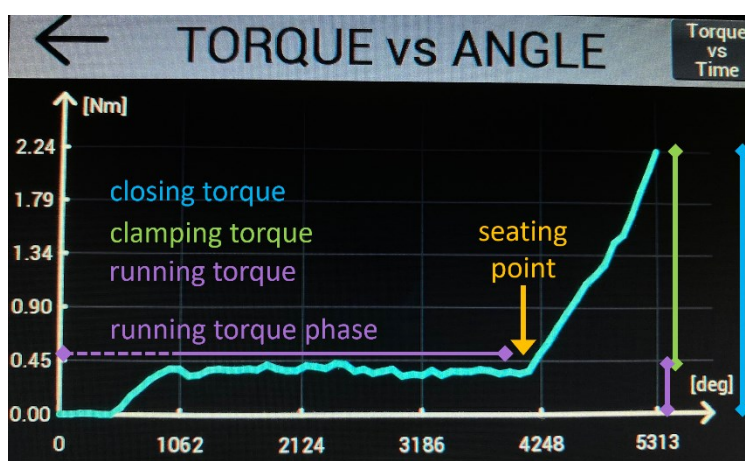

Example

Target torque: 2.22 Nm

Seating point: 4000°

PV / Running torque estimate: 0.3 Nm

(PV / Running torque mode OFF)

Test with Prevailing / Running torque monitoring only

In the [ADVANCED TORQUE menu](#) configure the Prevailing / Running torque [WINDOW](#) by angle (or time), such that it always ends **before** the seating point. Use a window max value of at most the lowest seating angle point identified in the test tightenings.

Select appropriate Prevailing / Running torque MIN-MAX bounds, such that the Prevailing / Running torques measured fall within the bounds, while retaining the ability to detect incorrect values.

Select peak or average [VALUE](#) depending on the requirements of the application and shape of the graph.

If the PV / Running torque slopes upward, it may be appropriate to use the peak value.

If the PV / Running torque oscillates but is generally trending flat, it may be more appropriate to use the average value.

Finally, select monitoring [MODE](#) for a second round of testing without compensating for the Prevailing / Running torque.

Perform another batch of tightenings, and check if the detected Prevailing / Running torque value is the one expected.



Example

Target torque: 2.22 Nm

PV / Running torque mode:
Average - Monitoring

Window: 270° – 4000°



Example

The PV / Running torque window was incorrect: it extended past the seating point.

Final test with Prevailing / Running torque compensation

After fine-tuning the Prevailing / Running torque detection, switch to compensate [MODE](#). The system will now add the Prevailing / Running torque value measured on each tightening to the target torque.

Perform another batch of tests and analysis to verify the desired result.



Example

Target torque: 2.22 Nm

PV / Running torque mode:
Average - Compensate

Window: 270° – 4000°



Example

Target torque: 0.30 Nm

PV / Running torque mode:
Average - Compensate

Window: 270° – 900°

MAX POWER PHASE

Self-threading applications may require a “Max Power Phase” strategy, if the initial torque required to overcome the self-threading action is higher than the target closing torque.

In the [ADVANCED TORQUE menu](#), activate the “Max Power Phase” with a time or angle value duration counted starting from the time the lever is pressed.

Warning: for the duration of this phase, the screwdriver will only stop if it reaches its maximum torque possible.



A tightening with target torque 0.21 Nm, and “Max Power Phase” for 2.0 seconds. Note how the maximum torque is higher than the final torque. This type of profile is only possible through the “Max Power Phase”, otherwise the tightening would end at roughly the 0.30 seconds mark when first encountering the target torque of 0.21 Nm

CROSSTHREAD DETECTION

To detect cross threading without stripping the fastener, use the following settings:

PV / RUNNING TORQUE: **ANGLE** or **TIME**. Select a window where to detect cross threading.

VALUE: select **PEAK** or **AVERAGE**. In either mode, the screwdriver stops immediately if it encounters the Prevailing / Running torque MAX torque during the Prevailing / Running torque window

MIN - MAX: set **MIN** to zero, and set **MAX** to a torque high enough to disregard normal friction, but low enough to detect cross threading without stripping the screw

MODE: select **Monitoring**, to avoid adding the Prevailing / Running torque value to the torque target

This will make the screwdriver stop at the Prevailing / Running Torque “MAX” value if it is encountered within the set ANGLE or TIME window.

For example, if the target torque is 5 Nm, and the Prevailing / Running Torque “MAX” value is 0.6 Nm, and the driver encounters a torque of 0.6 Nm within the Prevailing/Running Torque WINDOW, it will stop at 0.6 Nm with an error message, without applying the 5 Nm of torque which could damage the assembly when the screw has cross-threaded.

MULTI-STEP AND COMBINED PROGRAMS

To reverse the screwdriver at the beginning of the tightening, or after reaching the closing torque, or to change the direction of tightening, refer to the corresponding options in the [REVERSE, RAMP, TIME menu](#).

To combine multiple programs in a single tightening, you can configure a sequence with the [Program transition box](#) set to “auto”.

The sequence will then transition between two or more programs automatically while the operator continues to hold the screwdriver lever. The screwdriver will stop momentarily in-between programs. Activate the [LEVER ERROR](#) setting for each program involved to raise an error if the operator stops holding the lever during or in between the programs.

This allows to have multi-program tightening strategies.

MAIN MENU

From the main screen, enter the main menu by tapping on the ☰ button on the top right.

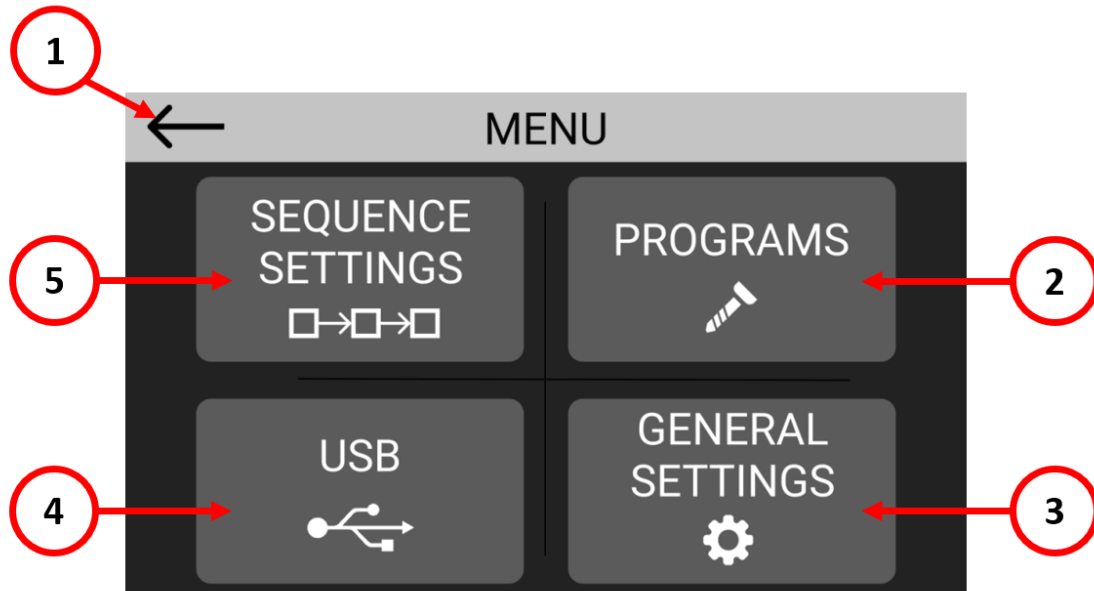

- (1) Touch to return to the main screen.
- (2) Touch to enter the program configuration menu, to configure parameters such as torque, angle, runtime, for each program. You can configure up to 200 different programs.
- (3) Touch to enter the general settings menu, to configure general parameters such as passcode lock, I/O and MODBUS settings, kolver accessories, language, etc.
- (4) Touch to enter the USB menu to save or load settings from a USB drive. Note: if a USB drive is connected, the unit automatically saves all screwdriving results in a text file.
- (5) Touch to enter the sequence configuration menu, to configure a sequence of up to 32 different programs and the type of transition between each program.

PROGRAMS menu

Programs represent batches of one or more screws sharing the same parameters (torque, angle, speed, etc). With the K-DUCER series, you can define up to 200 different programs as well as assign a barcode to each for automatic selection with a barcode scanner.

Tap the Programs button from the main menu to enter the programs menu.

Select one of 200 programs to edit by tapping on the program number or the arrows on the top bar.

Enter one of the four sub-menus to modify the desired parameters for the program selected.

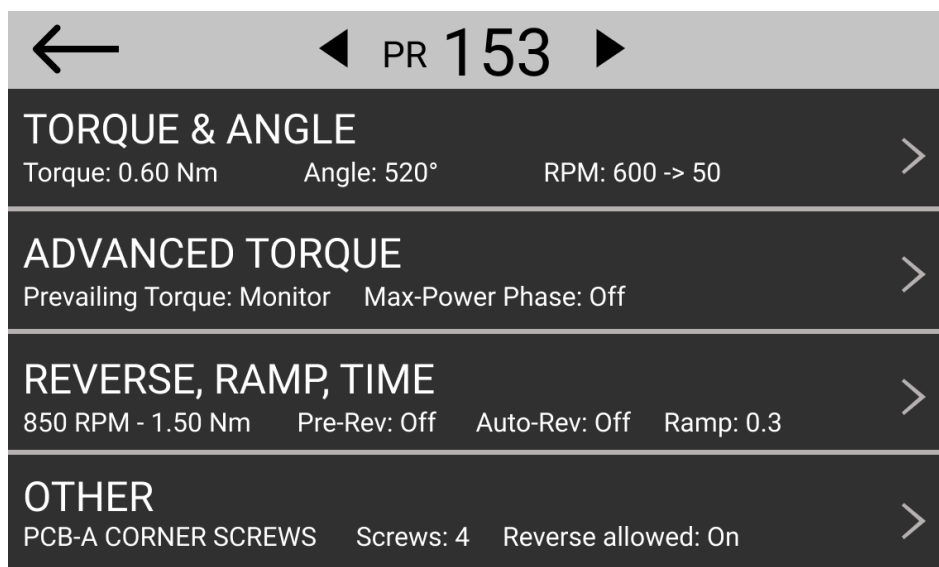

TORQUE & ANGLE menu

Note: carefully choosing the right combination of speed and downshift settings for the application will maximize the precision and lifetime of the tool while minimizing your assembly cycle time. Review the [Determining the appropriate program settings](#) section.

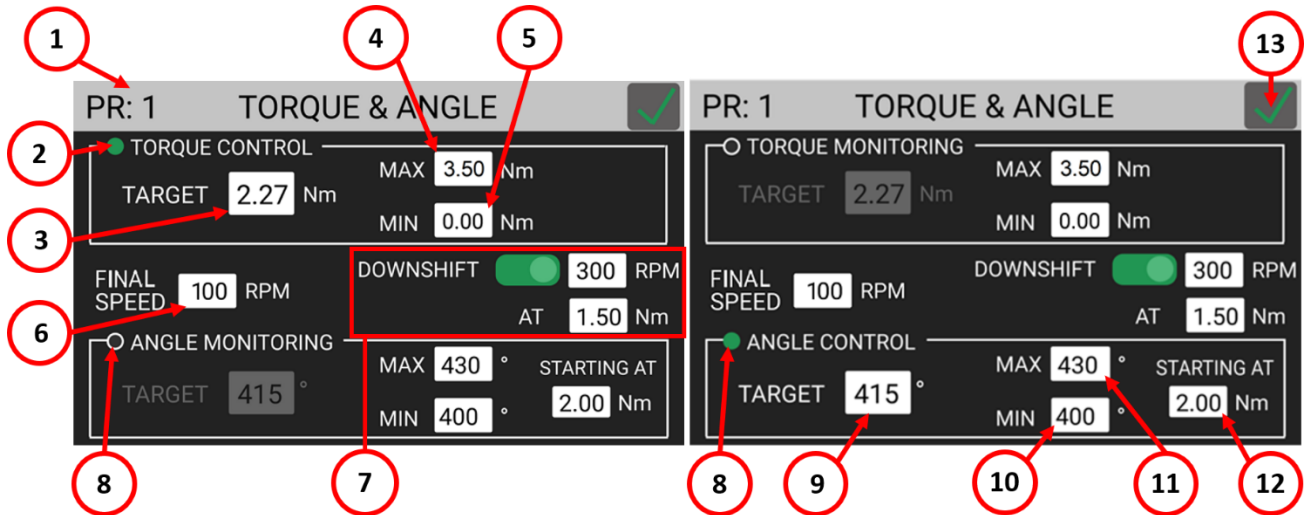

(1) Program Number

Indicates the program that is currently being edited. You can select a different program to edit from the previous screen.

(2) TORQUE CONTROL / ANGLE MONITORING flag

Tap to select Torque Control and Angle Monitoring mode.

In this mode, the screw is tightened down to the target torque, and the angle (the number of revolutions of the screw, in degrees) reached at the target torque is measured. The STARTING AT (12) setting controls the starting point for the angle measurement (at torque threshold, at lever pressed, or at external signal received).

(3) TARGET Torque

Tap to set the target torque. Only available in Torque Control/Angle Monitoring mode. For prevailing torque settings, see the ADVANCED TORQUE menu.

Note: continuous use at or over 80% of the screwdriver's nominal torque range is not recommended.

(4) MAX Torque

If the torque measured at the end of the tightening exceeds the MAX Torque value, the tightening will be considered unsuccessful (NOK) and a corresponding error will be raised. Applicable to Torque Control as well as Angle Control modes.

(5) MIN Torque

If the torque measured at the end of the tightening is below the MIN Torque value, the tightening will be considered unsuccessful (NOK) and a corresponding error will be raised. Applicable to Torque Control as well as Angle Control modes.

(6) FINAL SPEED

Tap to select the tightening speed of the screwdriver, in RPM.

If the (7) [DOWNSHIFT](#) function is used, this will be the final tightening speed that the screwdriver will downshift to after the selected “AT” threshold is reached.

For the reverse speed of the screwdriver, see the REV & PRE-REV. Note that you can invert the tightening and untightening directions of rotation via the PROGRAMS > OTHER menu.

(7) [DOWNSHIFT](#)

The DOWNSHIFT function lets you execute the tightening in two phases: a high speed approach (enter the speed in the “RPM” field), followed by a lower (6) [FINAL SPEED](#) after a certain torque or angle threshold is reached.

OFF (red): the screwdriver will run at the (6) [FINAL SPEED](#) for the entire tightening.

ON (green): the screwdriver will run at the entered “RPM” speed until a certain torque or angle is reached (AT torque/angle value), at which point it will downshift to the (6) [FINAL SPEED](#) for the remainder of the tightening.

If using an angle threshold, the angle is counted in accordance with the [STARTING AT](#) setting.

(8) [ANGLE CONTROL / TORQUE MONITORING flag](#)

Tap to select Angle Control and Torque Monitoring mode.

In this mode, the screw is tightened down to the target angle (number of revolutions of the screw, in degrees), while the torque is measured.

(9) [TARGET Angle](#)

Tap to set the target angle. Only available in Angle Control/Torque Monitoring mode.

(10) [MIN Angle](#)

If the angle measured at the end of the tightening is below the MIN Angle value, the tightening will be considered unsuccessful (NOK) and a corresponding error will be raised. Applicable to Torque Control as well as Angle Control modes.

(11) [MAX Angle](#)

If the angle measured at the end of the tightening exceeds the MAX Angle value, the tightening will be considered unsuccessful (NOK) and a corresponding error will be raised. Applicable to Torque Control as well as Angle Control modes.

(12) [STARTING AT](#)

Tap to select the starting point for the angle measurement. Three modes are available:

- **Torque threshold:** the angle measurement starts after the torque reaches this value
- **Lever:** the angle measurement starts as soon as the screwdriver level is pressed
- **Ext In:** the angle measurement starts after the IN-ANG external I/O signal is received

(13) [Exit/Save key](#)

Tap to return to the previous menu and save or discard any changes made. Hold YES to save and exit back to the main screen (shortcut on firmware v39 and later only).

ADVANCED TORQUE menu

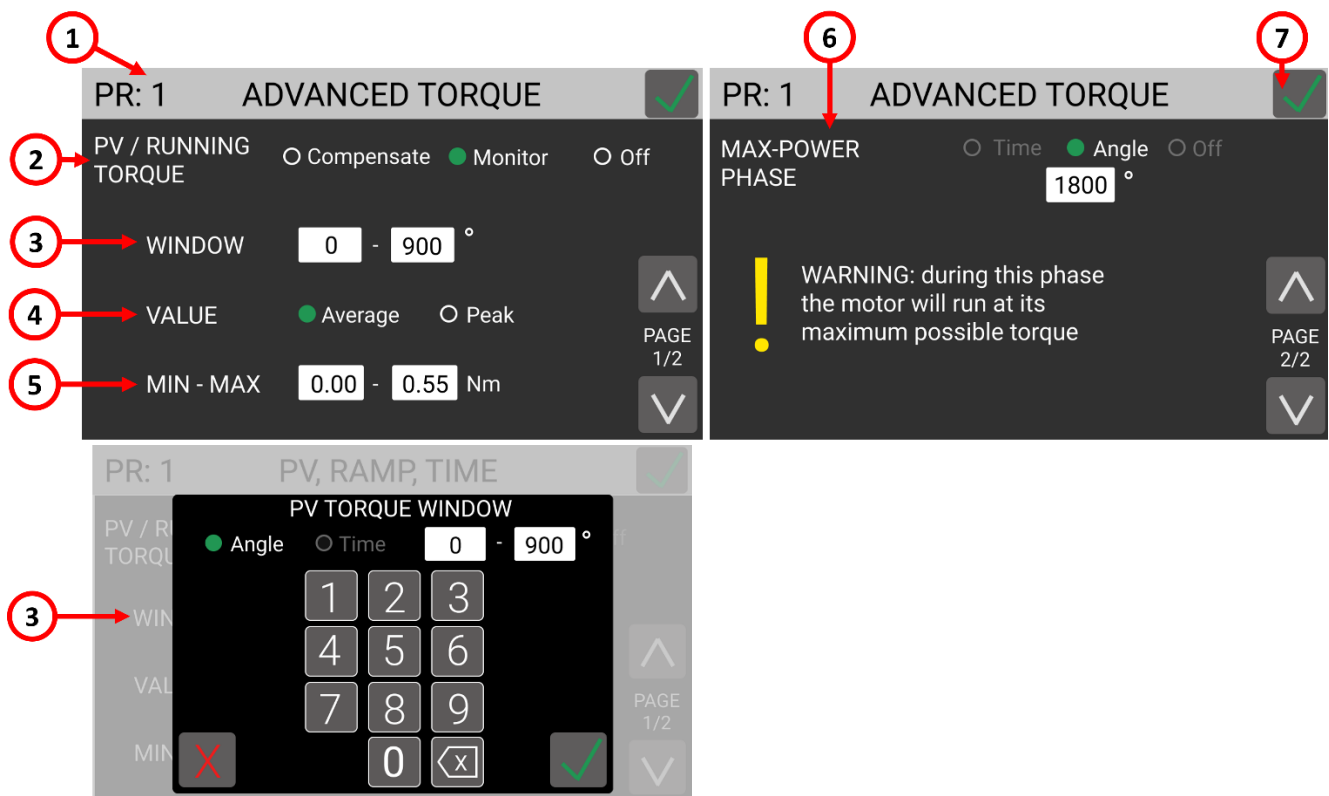

(1) Program number

Indicates the program that is currently being edited. You can select a different program to edit from the previous screen.

(2) PV / RUNNING TORQUE

The PREVAILING TORQUE (RUNNING TORQUE) function makes the screwdriver **add (compensate) or monitor** the peak or average torque measured during the set window to the final target torque, in real time. This function is required in select aerospace and helicoil application, where a fixed “clamping torque” is to be applied on top of a variable “prevailing torque” (running torque, thread locker torque, friction torque...) encountered during the rundown.

Refer to the [RUNNING TORQUE](#) section for more information.

Off: the function is not active.

Compensate: the running torque value will be added to the [TARGET Torque](#) in real time, to achieve a fixed amount of **clamping torque**.

Monitor: the running torque will only be measured, and the system will target the unmodified [TARGET Torque](#).

(3) WINDOW

Enter the time or angle window during which the running torque will be measured.

Angle: the running torque is measured within the angle window selected, counted in accordance with the [STARTING AT](#) setting.

Time: the running torque is measured within the time window selected, starting from the moment the screwdriver lever (or remote lever command) is pressed.

(4) VALUE

Average: the running torque value will be the average of the torque values measured during the running torque window.

Peak: the running torque value will be the maximum torque value measured during the running torque window.

(5) MIN - MAX

At the end of the running torque phase, the calculated running torque value (peak or average) is compared against these MIN/MAX limits and an error is raised if it falls outside these limits.

The tightening also stops immediately if the instantaneous running torque exceeds the MAX value during the running torque phase, unless the “MAX POWER PHASE” is enabled and superimposed on the running torque window.

Examples of tightening results using the PV/RUNNING TORQUE functions:

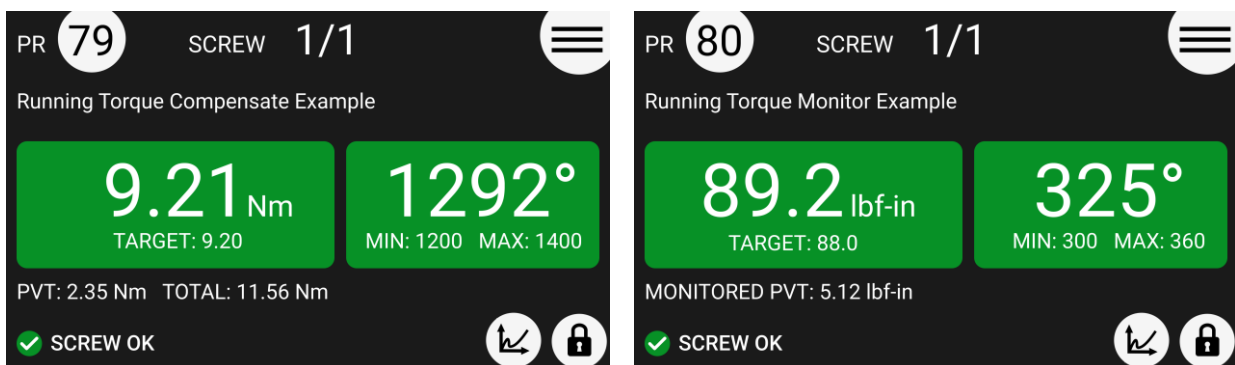

(6) MAX POWER PHASE

The MAX POWER PHASE function makes the screwdriver work at maximum torque from the beginning of the rundown until the set time or angle are reached.

WARNING: This function is useful for applications where the prevailing torque is higher than the final target torque (for example self-tapping screws or locknuts). Please use this function with the utmost attention because an incorrect use can damage both the assembly and the screwdriver!

If the torque measured during the prevailing torque time exceeds the maximum torque achievable by the screwdriver, in other words, if the screwdriver stops turning during the prevailing torque phase, “Error pvt time” will be displayed.

If OFF, this functionality is disabled.

(7) Exit/Save Key

Tap to return to the previous menu and save or discard any changes made. Hold YES to save and exit back to the main screen (shortcut on firmware v39 and later only).

REVERSE, RAMP, TIME menu

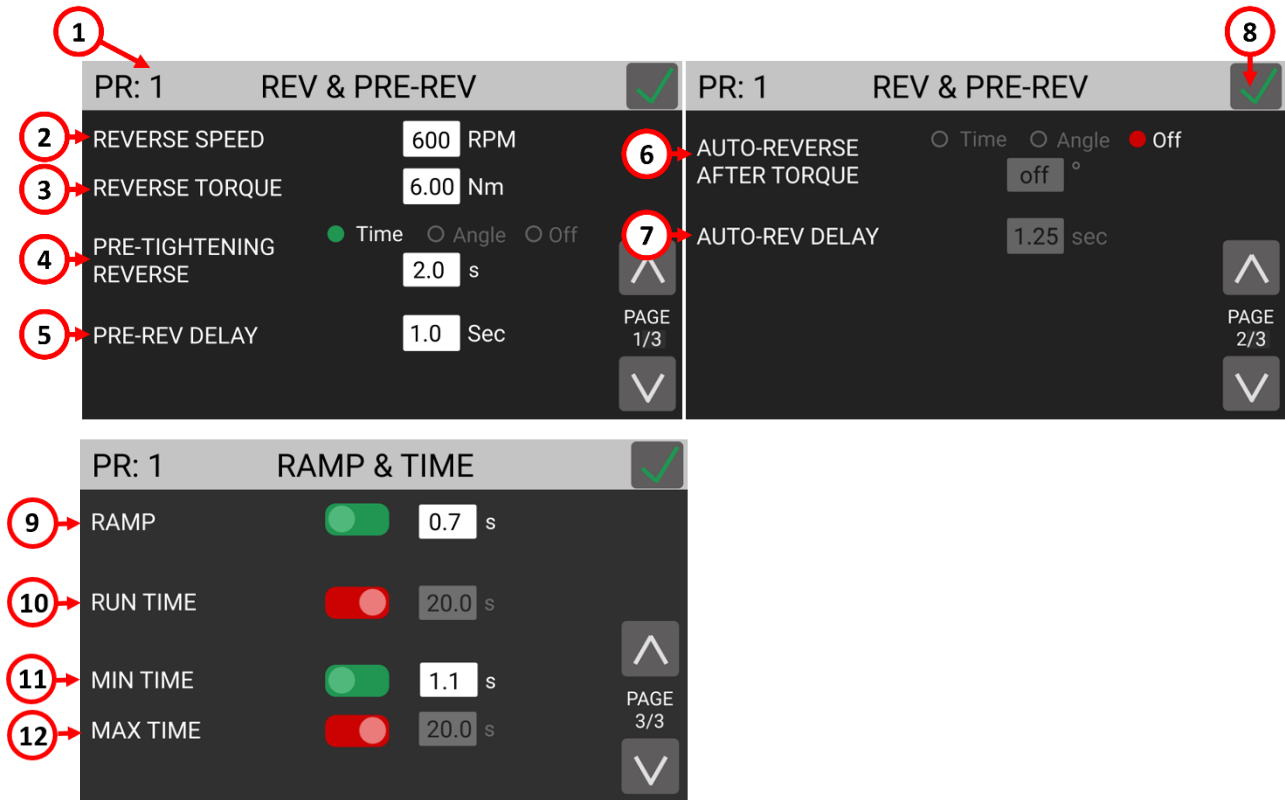

(1) Program number

Indicates the program that is currently being edited. You can select a different program to edit from the previous screen.

(2) REVERSE SPEED

Tap to select the untightening speed of the screwdriver, in RPM.

WARNING: This setting also applies to the PRE-TIGHTENING REVERSE and AUTO-REVERSE AFTER TORQUE functions.

Settings from the TORQUE & ANGLE and RAMP & TIME menu do not apply when untightening.

Note that you can invert the tightening and untightening direction of rotation via PROGRAMS > OTHER > [ROTATION](#).

(3) REVERSE TORQUE

Tap to set the maximum reverse torque that the screwdriver will allow while untightening, within the range of the screwdriver selected.

WARNING: This setting also applies to the PRE-TIGHTENING REVERSE and AUTO-REVERSE AFTER TORQUE functions.

If you're using an open-end wrench attachment, the reverse torque should be set to MIN value in order to bring the wrench back to the correct position.

(4) PRE-TIGHTENING REVERSE

This function makes the screwdriver turn in the reverse direction for a set time duration or angle, before starting the normal rundown.

The speed and torque utilized in the PRE-TIGHTENING REVERSE phase are set in the REVERSE SPEED and REVERSE TORQUE settings above.

If OFF, this functionality is disabled.

(5) PRE-REV DELAY

The amount of idle time between the end of the PRE-TIGHTENING REVERSE phase and the tightening phase. The lever must remain pressed or the remote start command must remain active during this idle time. Cannot be set to less than 0.3 seconds. Only active if the PRE-TIGHTENING REVERSE function is not OFF.

(6) AUTO-REVERSE AFTER TORQUE

This function makes the screwdriver turn in the reverse direction for a set time duration or angle after successfully completing the tightening phase.

The speed and torque utilized in the PRE-TIGHTENING REVERSE phase are set in the REVERSE SPEED and REVERSE TORQUE settings above.

This function activates only if the screw result from the tightening phase was OK. If there was an error in executing or completing the tightening phase, the screwdriver will not proceed with the AUTO-REVERSE AFTER TORQUE phase.

WARNING: the lever must remain pressed or the remote start command must remain active during the entire AUTO-REVERSE AFTER TORQUE phase, otherwise the screwing result will be NOK and an error will be raised.

If OFF, this functionality is disabled.

Note: if the tightening phase was successful, the OK signal will not be raised until the completion of the AUTO-REVERSE AFTER TORQUE phase. The TORQUE and ANGLE results displayed at the end of the AUTO-REVERSE AFTER TORQUE phase will correspond to the torque/angle results from the tightening phase, and not those from the AUTO-REVERSE AFTER TORQUE phase.

(7) AUTO-REV DELAY

The amount of idle time between the end of the tightening phase and the AUTO-REVERSE AFTER TORQUE phase. The lever must remain pressed or the remote start command must remain active during this idle time. Cannot be set to less than 0.3 seconds. Only active if the AUTO-REVERSE AFTER TORQUE function is not OFF.

(8) Exit/Save Key

Tap to return to the previous menu and save or discard any changes made. Hold YES to save and exit back to the main screen (shortcut on firmware v39 and later only).

(9) RAMP

The ramp function makes the screwdriver gradually accelerate to the target SPEED. Enter a time between 0.3 and 3 seconds to set the duration of the ramp phase.

OFF: the screwdriver starts immediately turning at the target SPEED when the lever is pressed (or when the screwdriver starts through remote control).

ON: the screwdriver speed will ramp up to the target SPEED in the time set.

If you wish to display an error when the screwdriver reaches target torque or angle during the ramp phase, use the (11) MIN TIME function with a timer value equal to the RAMP timer.

(10) RUN TIME

The RUN TIME function makes the screwdriver stop after the set timer, irrespective of the torque or angle reached.

ON: the screwdriver will stop after the set amount of time or when the torque or angle targets are reached, whichever event happens first. If the run time is reached before the target torque or angle, then the torque and angle reached at the time the screwdriver stops will be displayed and will be used to determine whether the result was OK or NOK depending on the min/max limits set on torque, angle, and/or time.

OFF: the screwdriver will turn indefinitely until the target or max limits set on torque, angle, and/or time are reached.

(11) MIN TIME

The MIN TIME function makes the screwing result NOK (error) if the target torque or angle is reached before the set minimum time.

ON: "Below minimum time" error will be displayed if target torque or angle is reached before the set minimum time, counting from the moment the lever is pressed or a remote start signal is received.

OFF: this functionality is disabled.

(12) MAX TIME

The MAX TIME function makes the screwing result NOK (error) if the target torque or angle is not reached before the set maximum time.

ON: "Over maximum time" error will be displayed if target torque or angle is not reached before the set maximum time, counting from the moment the lever is pressed or a remote start signal is received.

OFF: this functionality is disabled.

OTHER menu

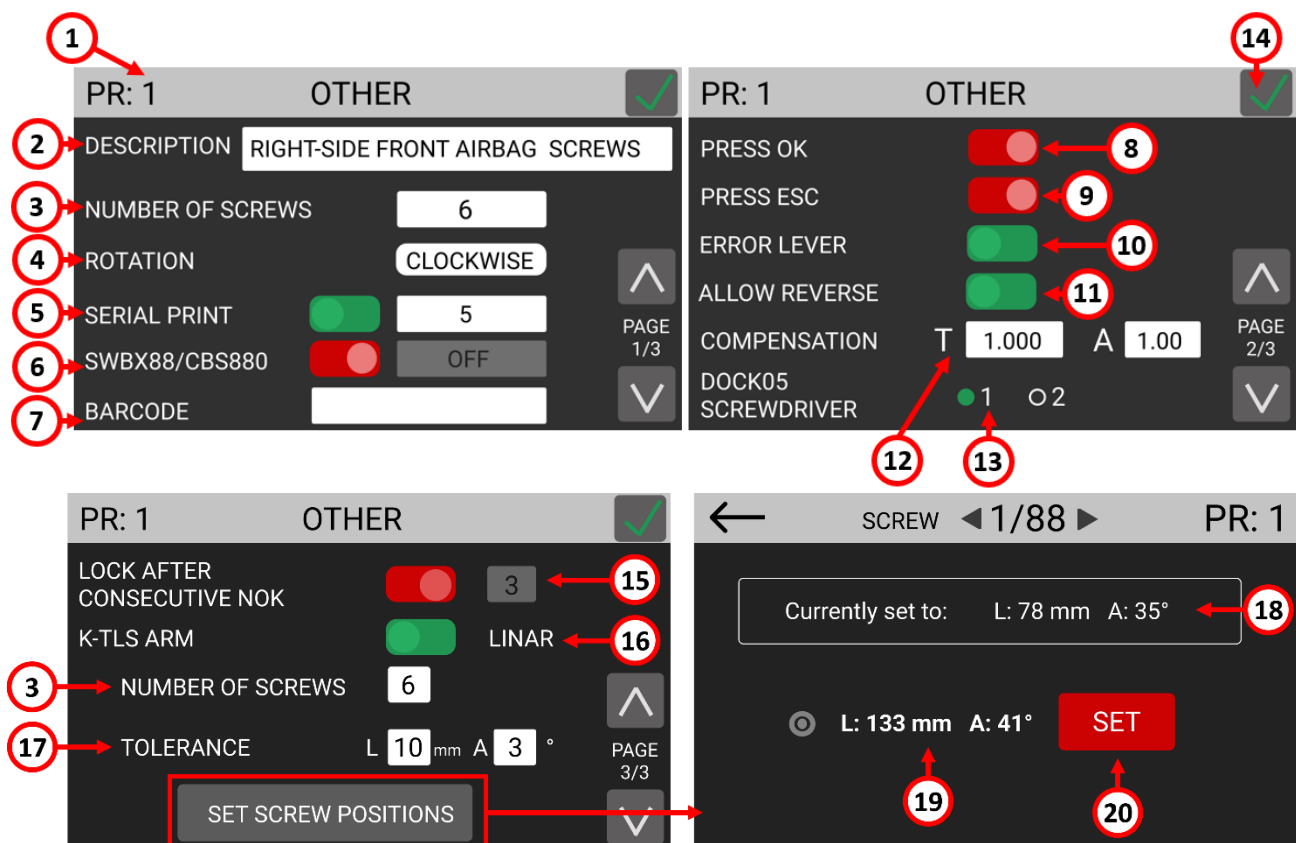

The 'OTHER' menu is divided into several sections:

- Top Left (1-7):**
 - 1: PR: 1
 - 2: DESCRIPTION: RIGHT-SIDE FRONT AIRBAG SCREWS
 - 3: NUMBER OF SCREWS: 6
 - 4: ROTATION: CLOCKWISE
 - 5: SERIAL PRINT: 5
 - 6: SWBX88/CBS880: OFF
 - 7: BARCODE
- Top Right (8-14):**
 - 8: PRESS OK (toggle)
 - 9: PRESS ESC (toggle)
 - 10: ERROR LEVER (toggle)
 - 11: ALLOW REVERSE (toggle)
 - 12: COMPENSATION T: 1.000
 - 13: COMPENSATION A: 1.00
 - 14: DOCK05 SCREWDRIVER (radio buttons 1 and 2)
- Bottom Left (15-17):**
 - 15: LOCK AFTER CONSECUTIVE NOK: 3
 - 16: K-TLS ARM: LINAR
 - 17: TOLERANCE: L 10 mm A 3°
- Bottom Right (18-20):**
 - 18: Currently set to: L: 78 mm A: 35°
 - 19: L: 133 mm A: 41°
 - 20: SET button

Navigation buttons (PAGE 1/3, 2/3, 3/3) and a 'SET SCREW POSITIONS' button are also visible.

(1) Program number

Indicates the program that is currently being edited. You can select a different program to edit from the previous screen.

(2) DESCRIPTION

Tap to enter a program description of up to 30 alphanumeric characters. The description will be displayed in the main screen.

(3) NUMBER OF SCREWS

Tap to set the number of screws for this program. Also referred to as “batch size” in the industry. The end of program signal will be raised upon the successful tightening of the last screw in the program.

Enter zero to disable screw counting for this program.

Note: a program with NUMBER OF SCREWS set to zero behaves the same as a program with NUMBER OF SCREWS set to one when utilized in a sequence.

(4) ROTATION

Tap to set the direction of rotation of the screwdriver for the tightening phase. All of the screwdriver functions (angle measurements, direction of rotation for reverse phase, etc.) will adapt to the selected direction of rotation.

(5) SERIAL PRINT

Tap to enable and set a value from OFF to 5. The value identifies the number of line feeds (empty lines) printed between a results string and the next on the serial ports (CN2 and CN4) and serial printer accessory. Affected by the [RESULTS FORMAT](#) setting. If OFF, no data will be transmitted through CN2 or CN4.

(6) SWBX88/CBS880

Tap to enable and utilize the SWBX88 or CBS880 Kolver accessories with the current program being edited.

Enter 1 through 8 to assign the current program ([Program number](#)) number to the corresponding physical slot (1 through 8) of the Kolver accessory.

See [Connecting a bit-tray or switchbox \(CBS880, SWBX88\)](#) for more details.

(7) BARCODE

Tap to enter the SCAN BARCODE screen to assign a barcode to the current program being edited. To be used in conjunction with the BARCODE MODE: - ON PRG - in the GENERAL SETTINGS menu.

The PROGRAM barcode can be up to 16 alphanumeric characters. QR codes of up to 16 alphanumeric characters are supported, provided that the scanner is configured correctly (RS-232, 9600 baud, 8 data bits, 1 stop bit, no parity).

(8) PRESS OK

ON: the “press OK” screen will appear upon successful completion of the last screw of the program.

When this screen appears, the screwdriver will remain disabled until the operator taps OK on the touch screen, or until the “REMOTE OK” external signal is received.

OFF: the control unit will reset automatically when the lever is pressed or the remote start signal is received after the last screw of the program is successfully completed.

Note: the “press OK” screen will not appear if the NUMBER OF SCREWS is set to zero, even if enabled. If you want the “press OK” screen to appear after every screw, set NUMBER OF SCREWS to one.

Note: this setting is ignored if the program is being used within a sequence (job). The program transition setting within the sequence will define the behavior in this case.

(9) PRESS ESC

ON: the “press ESC” screen will appear whenever an error occurs during a tightening or untightening operation.

When this screen appears, the screwdriver will remain disabled until the operator taps ESC on the touch screen, or until the “REMOTE ESC” external signal is received.

OFF: the control unit will clear the error automatically when the lever is pressed or the remote start signal is received after the error occurs (in this case, the remote start signal must first be pulled down after the error occurs in order to re-start the tightening).

(10) LEVER ERROR

ON: an error will be raised if the lever is released before reaching the target torque, angle, and/or run time.

OFF: releasing the lever in the middle of a tightening will not result in an error signal, even if the target torque, angle, and/or run time have not been reached.

(11) DEFIX ALLOW

ON: the reverse button on the screwdriver is enabled for this program.

OFF: to disable the reverse button on the screwdriver for this program.

Note: the PRE-TIGHTENING REVERSE and AUTO-REVERSE AFTER TORQUE functionality can still be used when this setting is OFF.

(12) COMPENSATION

(T) (Torque)

This setting changes the calibration factor for the current program. Default value is 1. The torque measured when working with the current program is multiplied by this factor. For example, if a torque value of 3 Nm is displayed with the COMPENSATION setting at 1, but you measure an effective torque value of 3.03 Nm with an external measurement tool, you modify the COMPENSATION setting to 0.99. Repeating the tightening with the same joint should now yield a torque value of 3 Nm (result of $3.03 \text{ Nm} * 0.99$) in both the K-DUCER and the external torque measurement tool.

This function is useful when the torque result measured by an external instrument is not in line with the result measured by the K-DUCER, provided you are sure that the external instrument is properly calibrated and showing the correct result.

This can happen when working on rigid joints or with angle heads, or when the KDS screwdriver is overdue for a calibration.

WARNING: This function changes the value of the calibration factor of the KDS screwdriver (for the current program only) and therefore must be used only in case of real need and with a full understanding of what is being modified. In all other cases it should be left at 1. Contact your Kolver representative when in doubt. See

[CALIBRATION](#) for more details.

(A) (Angle)

This setting modifies the inertial angle compensation factor introduced with KDU v38. The default value is 1 and it allows improving the precision of target angle (or max angle) tightenings, especially in high speed and low load tightenings. It is normally not necessary and not recommended to modify this parameter.

(13) DOCK05 SCREWDRIVER

When pairing the Dock-05 dual output accessory with the DOCK-05 output pin on CN3, this setting determines which screwdriver (primary or secondary) is activated by the current program.

(14) Exit/Save Key

Tap to return to the previous menu and save or discard any changes made. Hold YES to save and exit back to the main screen (shortcut on firmware v39 and later only).

(15) LOCK AFTER CONSECUTIVE NOK

If ON, after the set number of consecutive NOK (failed) screw results, the controller will lock and ask for a password. This is useful when you want to force a production supervisor (or any operator who knows the password) to intervene in the uncommon situation of repeatedly and consecutively failing to achieve a screw OK result.

The password to be entered is the same password that protects the main menu, which is 0000 by default (four zeros).

Every OK result resets the consecutive NOK count to zero.

(16) K-TLS ARM

Turn ON to activate the K-TLS arm with position enforcement for this program.

If ON, the options below will be revealed.

Note: the NUMBER OF SCREWS parameter is reported below for convenience. It is the same parameter shown on Page 1.

Tap "SET SCREW POSITIONS" to enter the screw positions configuration screen.

(17) TOLERANCE

Set the tolerance for the position sensors of the K-TLS arm. The units will be in mm (millimeters) or degrees depending on the type of sensors that come with the arm. The tolerance represents the maximum allowed deviation from the center point of each screw position, beyond which the screwdriver will be disabled.

(18) Saved screw position

If a screw position has been set, it will be shown here.

(19) Arm position (real time)

Shows the arm sensor positions in real time.

(20) SET

Press to set the saved screw position (18) to the current real time position. This will overwrite the previously saved screw position, if present. It will also increase the screw counter by 1.

To set the screw positions of your part, simply move to each location and press SET above each one in the desired order or pattern.

If you need to reset a single screw position, use the arrows on the top bar to move between screws without overwriting their positions.

SEQUENCE SETTINGS menu

Sequences, also referred to as “jobs” in the industry, are ordered series of up to 32 programs with the option to define how to transition between programs.

With the K-DUCER series, you can define up to 24 different sequences as well as assign a barcode to each for automatic selection via a barcode scanner.

Tap the Sequence Settings button from the main menu to enter the sequence menu.

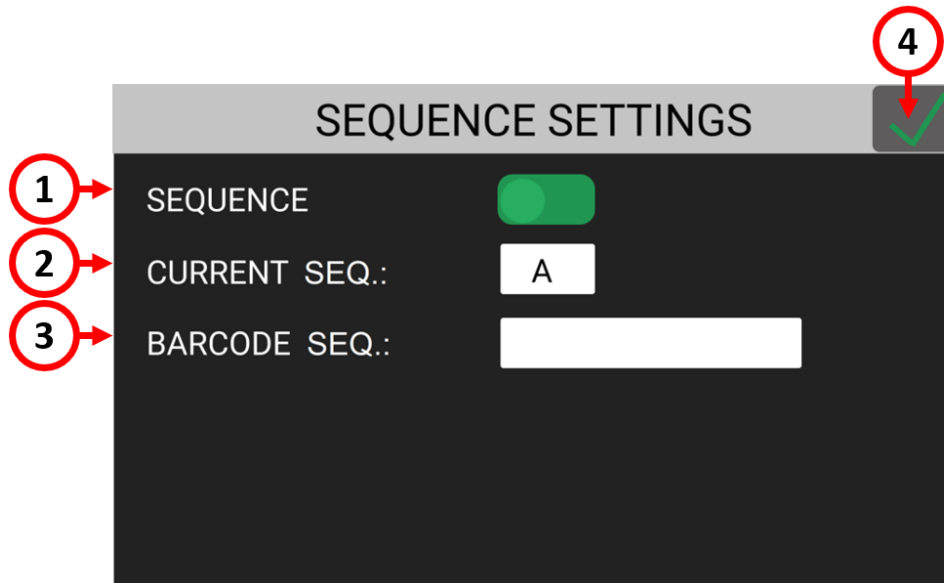

(1) SEQUENCE toggle

Tap the toggle to activate sequence mode in the main screen and work with sequences.

(2) CURRENT SEQ.

Tap the CURRENT SEQ. input field to enter the sequence edit menu for one of 8 sequences (A through X).

The sequence shown in the CURRENT SEQ. input field corresponds to the pre-selected sequence in the main screen.

You can also select a different sequence to work with directly from the main screen.

Manual selection of sequences is disabled if you utilize a [REMOTE SEQ](#) setting different from “Off”.

(3) BARCODE SEQ.

Tap to enter the SCAN BARCODE screen to assign a barcode to the sequence shown in CURRENT SEQ. To be used in conjunction with the BARCODE MODE: - ON SEQ - in the GENERAL SETTINGS menu.

The SEQUENCE barcode can be up to 16 alphanumeric characters. QR codes of up to 16 alphanumeric characters are supported, provided that the scanner is configured correctly (RS-232, 9600 baud, 8 data bits, 1 stop bit, no parity).

CURRENT SEQ. menu

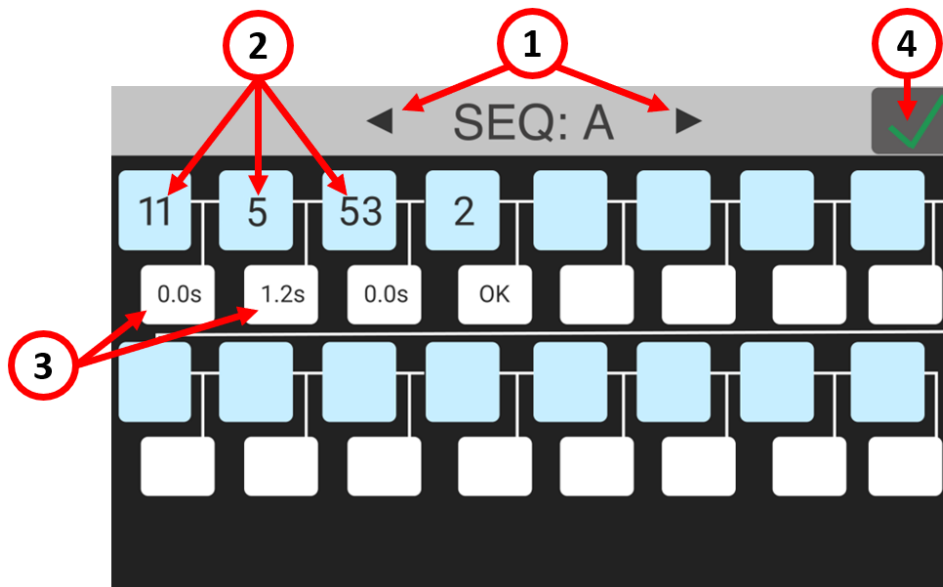

(1) Sequence letter

Indicates the sequence that is currently being edited.

Tap the arrows to select a different sequence to edit (A through X).

(2) Program number box

Tap to change or insert a program into the sequence. The sequence flows left to right, top to bottom.

You can insert any of the 200 programs into any of the 32 spots in the sequence. You can also insert the same program in different boxes if desired.

Note: upon adding the 16th program, an arrow will appear allowing to move to boxes 16 through 32.

(3) Program transition box

Tap the box to define the transition behavior between the two corresponding programs in the sequence.

The transition behavior can be:

Time: when the previous program is successfully completed, the unit will automatically switch to the next program after the set amount of time, in seconds. The screwdriver will remain disabled until the transition timer completes. The timer begins counting as soon as the program is completed, even if the lever is not depressed or the remote start command is not removed. The allowable range is 0.3 to 10 seconds.

OK: when the previous program is successfully completed, the “press OK” screen will appear.

When this screen appears, the screwdriver will remain disabled until the operator taps OK on the touch screen popup, or until the “REMOTE OK” external signal is received.

Auto: when the previous program is successfully completed, the unit will immediately switch to the next program WITHOUT having to depress the screwdriver lever or pull down the remote start command. This setting can be useful if you require multiple closing torques or angles on the same joint without stopping in between, or to create a

screwdriving operation that is not otherwise possible within the parameters of a single program.

WARNING: use this transition setting with care and only when strictly necessary, as the operator will not have any time to react to the program change.

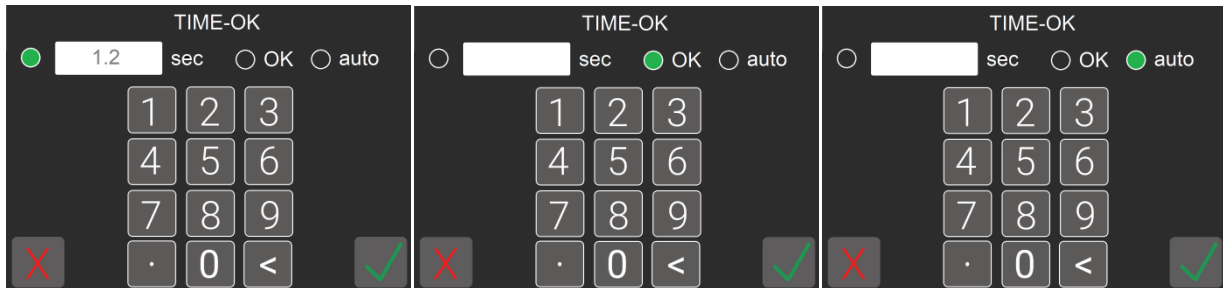

(4) Exit/Save Key

Tap to return to the previous menu and save or discard any changes made.

GENERAL SETTINGS menu

Tap the General Settings button from the main menu to enter the general settings menu. In this menu you can find information on the current KDS series screwdriver connected, configure Kolver accessories, configure I/O communications, add a password lock to the menu, and modify other settings that apply to all programs.

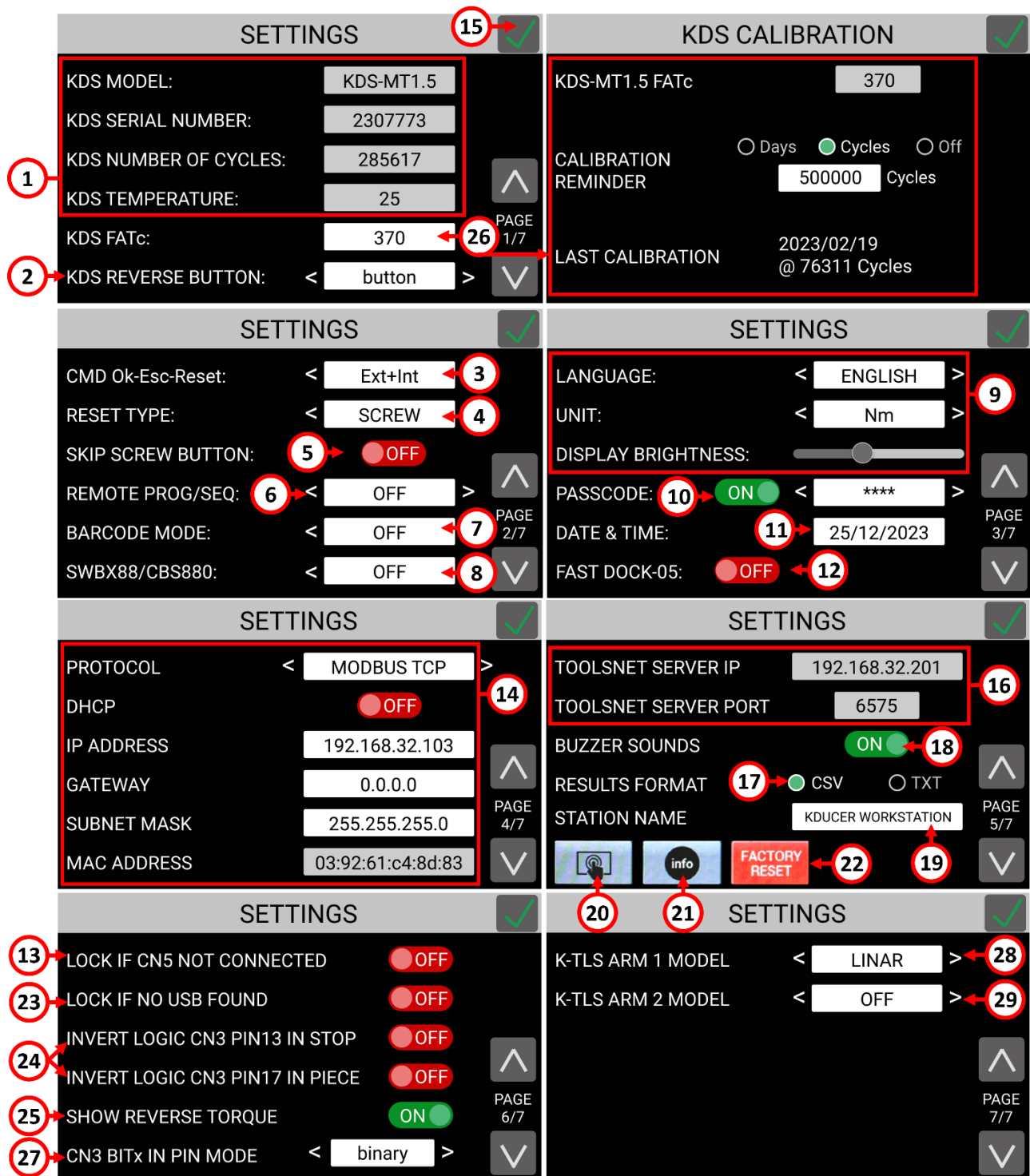

The following table summarizes the settings shown in the screenshots, with their corresponding numbers and values:

Screenshot	Setting	Value
1	KDS MODEL	KDS-MT1.5
1	KDS SERIAL NUMBER	2307773
1	KDS NUMBER OF CYCLES	285617
1	KDS TEMPERATURE	25
2	KDS FATc	370
2	KDS REVERSE BUTTON	< button >
3	CMD Ok-Esc-Reset	< Ext+Int >
4	RESET TYPE	< SCREW >
5	SKIP SCREW BUTTON	OFF
6	REMOTE PROG/SEQ	< OFF >
7	BARCODE MODE	< OFF >
8	SWBX88/CBS880	< OFF >
9	LANGUAGE	< ENGLISH >
9	UNIT	< Nm >
10	PASSCODE	ON
11	DATE & TIME	25/12/2023
12	FAST DOCK-05	OFF
14	PROTOCOL	< MODBUS TCP >
14	DHCP	OFF
14	IP ADDRESS	192.168.32.103
14	GATEWAY	0.0.0.0
14	SUBNET MASK	255.255.255.0
14	MAC ADDRESS	03:92:61:c4:8d:83
16	TOOLSNET SERVER IP	192.168.32.201
16	TOOLSNET SERVER PORT	6575
17	RESULTS FORMAT	CSV
18	BUZZER SOUNDS	ON
19	STATION NAME	KDUCER WORKSTATION
20	Factory Reset Button	Factory Reset
21	Info Button	Info
22	Factory Reset Button	Factory Reset
23	LOCK IF CN5 NOT CONNECTED	OFF
23	LOCK IF NO USB FOUND	OFF
24	INVERT LOGIC CN3 PIN13 IN STOP	OFF
24	INVERT LOGIC CN3 PIN17 IN PIECE	OFF
25	SHOW REVERSE TORQUE	ON
27	CN3 BITx IN PIN MODE	< binary >
28	K-TLS ARM 1 MODEL	< LINAR >
29	K-TLS ARM 2 MODEL	< OFF >

(1) TOOL INFO

Shows information of the connected screwdriver:

MODEL: the model of the connected screwdriver.

SERIAL NUMBER: the serial number of the connected screwdriver.

NUMBER OF CYCLES: the total cumulative number of cycles performed by the screwdriver. Also see [MAINTENANCE AND CARE](#) section.

TEMPERATURE: the temperature measured near the motor of the screwdriver, in degrees °C.

Note: exceeding a temperature of 40 °C will put the screwdriver in error protection mode and lock it until it cools down below 37 °C.

Some factors that can overwork and overheat the screwdriver include:

- Combination of high torque and low speed on very elastic joints (the screwdriver delivers high torques more efficiently at higher speeds)
- Very high duty cycles (< 3 seconds between tightening), depending on difficulty (torque/elasticity) of the tightening
- High torques are defined as above 80% of the maximum nominal torque for the KDS screwdriver model. Consider upsizing the screwdriver model if most of your cycles are > 80% of the maximum torque

(2) KDS REVERSE BUTTON

Defines the behavior of the reverse button on the KDS screwdriver and on the remote reverse command. The two modes available are BUTTON and SWITCH.

BUTTON mode: the screwdriver will run in reverse only while pressing the reverse button on the KDS screwdriver or while sending the remote reverse command.

SWITCH mode: pressing and releasing the reverse button on the KDS screwdriver or sending the remote reverse command will activate the reverse mode on the KDS screwdriver. Press the lever on the KDS screwdriver or send the remote start command while in this mode to make the screwdriver run in reverse. The LEDs on the screwdriver will flash while this mode is active and the screwdriver is not turning.

(3) CMD OK-ESC-RESET

Changes the source for the commands "OK", "ESC" (see "press OK" and "press ESC" settings on the PROGRAMS > OTHER menu), and "RESET" (see (4) below).

Choose "INT" (internal) to only allow these inputs from the touch screen display.

Choose "EXT" (external) to only allow these inputs to be received via external signals on the CN3 connector.

Choose "INT+EXT" to allow the OK/ESC/RESET commands from both the touch screen display and the external signals on CN3.

(4) RESET TYPE

Defines the behavior of the reset ("RST") button and external reset signal.

OFF mode: disables the reset button and external signal.

PRG: resets the screws made counter of the current program to zero.

SCREW: decreases the screws made counter of the current program by one.

SEQ: resets the current sequence back to the first program and resets the screws made counter to zero. This option is will only appear if SEQUENCE mode is active ([SEQUENCE toggle](#) > ON).

If any barcode mode is active and the current [Screw count](#) is zero, the RST button/signal will also cause the “scan barcode” screen to reappear.

(5) **SKIP SCREW**

Enables/disables the skip screw button on the main screen. If enabled, pressing the “SKIP” button on the main screen will increase the screw count by 1.

(6) **REMOTE PR / SEQ**

Choose between one of four external program (PR) or sequence (SEQ) selection modes. SEQ version is shown if [SEQUENCE toggle](#) is ON.

OFF: the program or sequence is selected manually via the [Program \(“PR”\) number currently selected](#) button on the main screen.

CN3 I/O: the program or sequence is selected via the [24V I/O](#) remote control interface.

CN5 TCP: the program or sequence is selected via the ethernet [COMMUNICATION PROTOCOL](#).

SWBX/CBS: the program or sequence is selected via the Kolver accessory SWBX88 or CBS880. See [Connecting a bit-tray or switchbox \(CBS880, SWBX88\)](#) for more details.

Barcode: the program or sequence is selected via a barcode scanner. This option cannot be selected directly, but it is automatically selected with a compatible [BARCODE MODE](#) selection.

(7) **BARCODE MODE**

Choose between OFF or one of five barcode modes:

OFF: disables/ignores barcode scans and settings

On S.N. (“on Serial Number”): on the main screen, the scan barcode screen will appear. Scanning a barcode will temporarily associate it with the current program. The barcode will be printed in the corresponding results string on the serial port and on the corresponding Modbus field (see serial print and remote I/O chapters on this manual). The scan barcode screen will appear again after the current program completes on when a new program number is selected.

On PROG: on the main screen, the scan barcode screen will appear. Scanning a barcode will load the program containing the matching barcode. If there is no program with a matching barcode, the operator will be prompted to scan another barcode. The scan barcode screen will appear again after the loaded program completes. You can configure a unique barcode for each program via PROGRAM > OTHER > [BARCODE](#).

On SEQ: on the main screen, the scan barcode screen will appear. Scanning a barcode will load the sequence containing the matching barcode. If there is no sequence with a matching barcode, the operator will be prompted to scan another barcode. The scan barcode screen will appear again after the loaded sequence completes. You can configure a barcode for each sequence via the [BARCODE SEQ](#) setting on the [SEQUENCE SETTINGS](#) menu. This option is will only appear if SEQUENCE mode is active ([SEQUENCE toggle](#) > ON).

SN+Prog: This mode combines the “On Serial Number” and “On PROG” modes. First, the “scan serial number barcode” screen will appear. Then, after the first scan, the “scan PROG barcode” screen will appear. The program containing the barcode matching the “PROG” scan (second scan) will be loaded, while the first barcode scanned (“serial number”) will be printed with the screwdriving results.

Both “scan barcode” screens will reappear after the program completes.

SN+Seq: This mode combines the “On Serial Number” and “On SEQ” modes. First, the “scan serial number barcode” screen will appear. Then, after the first scan, the “scan SEQ barcode” screen will appear. The sequence containing the barcode matching the “SEQ” scan (second scan) will be loaded, while the first barcode scanned (“serial number”) will be printed with the screwdriving results.

Both “scan barcode” screens will reappear after the sequence completes.

Also see [Connecting a barcode scanner](#).

Note that the S/N barcode can also be transmitted via the MODBUS TCP or OPEN PROTOCOL [COMMUNICATION PROTOCOL](#).

Note: the maximum PROGRAM or SEQUENCE barcode length is 16 characters, while the maximum SERIAL NUMBER barcode length is 63 characters.

(8) **SWBX88/CBS880**

Changes the working mode for the SWBX88 and CBS880 Kolver accessories.

The working mode of the accessories also depends on whether [REMOTE PR](#) and [REMOTE SEQ](#) are set to SWBX/CBS.

See [Connecting a bit-tray or switchbox \(CBS880, SWBX88\)](#) for more details.

OFF: the accessory is completely disabled.

ON PROG: the position on the accessory is matched to the program number containing the corresponding SWBX88/CBS880 slot setting (Programs > Other > [SWBX88/CBS880](#)).

ON SEQ: the position on the accessory is matched to the sequence (A – 1, ... , 8 – H).

(9) **LANGUAGE / UNIT / BRIGHTNESS**

LANGUAGE: choose the display language: English, Italian, French, German, Spanish, Portuguese.

UNIT: choose the measurement units for torque: Nm, lbf.in, kgf.cm, oz.in

DISPLAY BRIGHTNESS: increase or decrease the brightness of the touch screen display

(10) **PASSCODE**

Enables or disables the passcode lock for the configuration menu.

Tap the input field to enter a passcode, and enable the on/off toggle to activate it.

When the passcode is enabled, the lock icon on the main screen will have a red background, and the passcode will be required to access the configuration menu.

Should you forget the passcode, contact Kolver to obtain a recovery passcode.

(11) **DATE & TIME**

Tap to change the date and time of the unit. This changes the date and time associated with each (new) result reported in the serial print, usb, and modbus fields.

(12) FAST DOCK-05

This option eliminates the “SCREWDRIVER CONNECTED” popup that appears for two seconds after connecting a KDS screwdriver to the controller.

When using the DOCK-05 accessory, enabling this option can be useful to reduce the idle time required to switch between the two drivers, and accelerate the cycle time.

(13) LOCK IF NOT CONNECTED

ON: the unit will remain locked and display an error message whenever there is no active connection established on the selected [COMMUNICATION PROTOCOL](#).

OFF: the unit will be able to work irrespective of the communication protocol status.

(14) COMMUNICATION PROTOCOL

PROTOCOL: select the communication protocol to use between the following options:

K-Expand: to interface with the free K-EXPAND PC software via the MiniUSB port.

MODBUS TCP: to interface with any device supporting the MODBUS TCP protocol via the ethernet port. This includes K-EXPAND and K-GRAPH via ethernet.

OPEN PROTOCOL: to interface with any device supporting Open Protocol via the ethernet port.

TOOLSNET: to interface with a ToolsNet database. The ToolsNet server IP address and port are set on the TOOLSNET SETTINGS below.

PROTOCOL 1 + PROTOCOL 2: select to utilize any two protocols simultaneously

DHCP: Toggle to enable/disable automatic DHCP assignment from a DHCP server.

IP ADDRESS: the ethernet IP address of the K-DUCER unit. If DHCP is ON, this field will show the assigned IP address (if none is shown, exit and re-enter this menu to refresh). If DHCP is off, enter here the static IP address to assign to the KDU controller.

GATEWAY: the ethernet IP address of the local network gateway, if applicable. You can leave this as 0.0.0.0 in most cases.

SUBNET MASK: the subnet mask of the local network. The value must match the subnet mask of the other devices in the LAN. Usually this value is 255.255.255.0. Note that 0.0.0.0 will not work in most cases. Contact your IT support if unsure.

MAC ADDRESS: shows the MAC address of the K-DUCER.

(15) Exit/Save Key

Tap to return to the previous menu and save or discard any changes made.

(16) TOOLSNET SETTINGS

To enable these settings, first select “TOOLSNET” on the [COMMUNICATION PROTOCOL](#) setting.

TOOLSNET SERVER IP: the IP address of the TOOLSNET PIM service

TOOLSNET SERVER PORT: the IP port of the TOOLSNET PIM service

The IP address and Port of the TOOLSNET PIM service may be specific to each facility or installation. These values can often be found by navigating to this address on a web browser connected to the TOOLSNET network: <http://127.0.0.1:6571>

Typical/default values for the TOOLSNET PIM SERVICE PORT: 6575, 9014, 9015, 6700
Contact your IT support if unsure.

(17) RESULTS FORMAT

Tap to select the format of the tightening results. This affects the results stored to the USB drive, the results transmitted via serial communication through CN2 and CN4, and the “Print String” MODBUS holding registers content.

CSV: (firmware v36 and later, default) Saves the results in Comma Separated Values format for easy import to spreadsheet programs. Selecting the CSV format also enables automatically saving the Torque and Angle graph data to the USB drive.

TXT: legacy format for the print string results. Torque/Angle graph data is not included. See section [Retrieving and storing the screwdriving results](#) for more details.

(18) BUZZER SOUNDS

Toggle to enable or disable the buzzer (beeper) sounds emitted by the unit.

(19) STATION NAME

Tap to assign a name to this controller, accessible via Open Protocol and K-Expand.

(20) TOUCH SCREEN CALIBRATION

Tap to enter the touch screen calibration function. Use this to correct problems with the alignment of the touch response of the display. Touch the three blue dots with one finger where they appear on the screen. Contact Kolver if the problem persists.

(21) INFO

Tap to show the firmware versions loaded onto the unit and onto the connected KDS screwdriver.

(22) FACTORY RESET

Tap to reset the unit to the factory default settings. You will be prompted to select a screwdriver model, this will determine the speed and torque values applied to all programs after the reset, such that they are compatible with the model selected. After the reset, you will be prompted to select the unit type – KDU-1 (model without ethernet port, discontinued in 2021) or KDU-1A (model with ethernet port). The model is printed on the label on the bottom side of the unit.

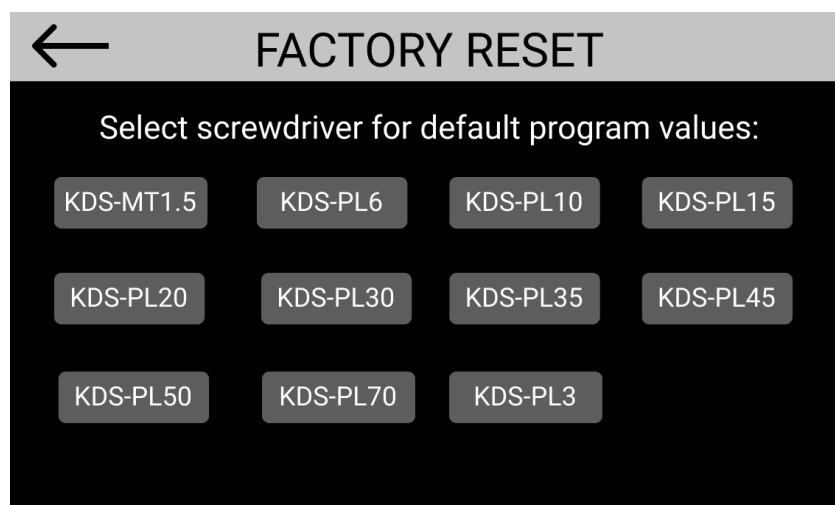

(23) LOCK IF NO USB FOUND

If ON, the controller will lock with an error message if there is no USB drive connected.

(24) INVERT LOGIC CN3 PIN 13/17 IN STOP/PIECE

If ON, inverts the input logic of the corresponding digital input pin on CN3. For example, if this setting is ON for PIN 13 (IN STOP), when Input PIN 13 is low (or disconnected), the KDS screwdriver motor will shut off and remain disabled (“Stop Motor”), whereas if this setting is OFF, the KDS screwdriver will shut off and remain disabled (“Stop Motor”) when Input PIN 13 is driven high. Also refer to the [24V I/O](#) chapter.

(25) SHOW REVERSE TORQUE (BREAKAWAY TORQUE)

If ON, when you use the KDS reverse button to reverse a screw/joint, the KDU controller will display the maximum torque measured when reversing. This is useful to measure the breakaway torque of a joint. For more information on measurement techniques for breakaway torque, see our blog post at <https://kolver.com/us/blog-detail/torque-auditing-measuring-fastened-bolts>

(26) KDS FATc CALIBRATION

Shows the calibration factor of the connected KDS screwdriver.

Tap to enter the KDS calibration and KDU calibration reminders screen, where you can edit the following settings:

- **KDS FATc:** editing this value requires the service passcode. Contact Kolver to obtain this passcode along with the calibration instructions and procedure for KDS screwdrivers. This information is stored on the KDS screwdriver itself.
- **CALIBRATION REMINDER:** enable/disable the calibration reminder. The calibration reminder is an unobtrusive message that appears on the status bar on the main screen whenever the set time or cycles have elapsed since the last calibration. The calibration reminder settings are stored on the KDU controller but are calculated with respect to the last calibration date/cycles of the connected screwdriver.
- **LAST CALIBRATION:** shows the date and cycles of the last time the **KDS FATc** value was modified. Every time you change the **KDS FATc** to a new value different from the last one, the last calibration date and cycles are updated on the KDS screwdriver. This information is stored on the KDS screwdriver itself. If you need to update the last calibration date/cycles information but want to keep the same **KDS FATc** value, change the KDS FATc value once, save/exit, and then revert the change back to the desired value.

(27) CN3 BITx IN MODE

Changes the logic of the program or sequence input selection signals on the CN3 connector. The different modes are described in the 24V I/O section of this manual.

(28) K-TLS ARM 1 MODEL

Select the K-TLS arm model, if one is connected. This enables the K-TLS option on the “Program => Other” menu.

(29) K-TLS ARM 2 MODEL

If a secondary K-TLS arm is connected, for use with a secondary screwdriver via the Dock05 accessory, select the model here. If you are not using two K-TLS arms, leave this option OFF or the primary arm will not function correctly.

USB menu

Tap the USB button from the main menu to enter the USB menu.

From this menu you can save and recall the K-DUCER configuration containing all program parameters, sequence parameters, and general settings, from a USB drive connected to the USB type-A port on the bottom of the unit.

Note: use the USB type A port for this function, not the mini-USB port.

Note: the USB drive must be formatted with the FAT32 filesystem.

If there is no USB drive connected, or if the USB drive is not formatted with **FAT32** filesystem, the following screen will appear. Connect a properly formatted USB drive to correct this error.

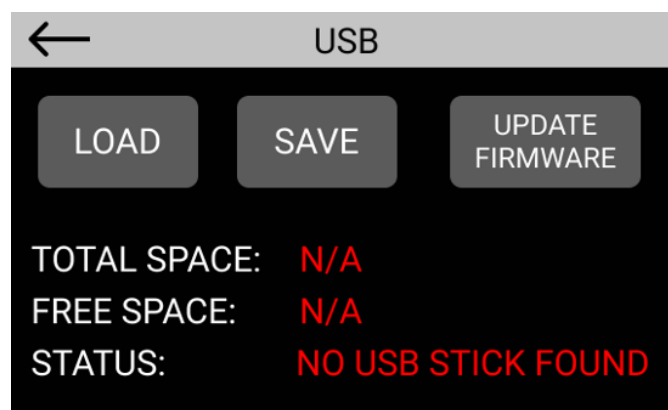

If a properly FAT32-formatted USB key is connected, the LOAD, SAVE, and UPDATE FIRMWARE buttons will be enabled:

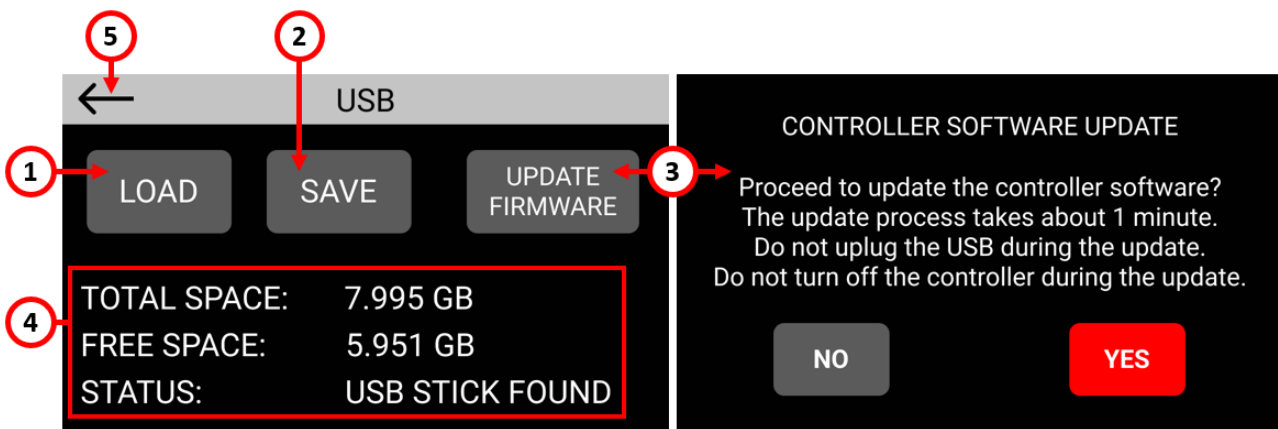

(1) LOAD programs button

Tap to display a list of KDU files found in the root directory of the USB drive.

Select the desired KDU file -the selected file will be highlighted in green-, previously saved from a K-DUCER unit or from the freely available K-EXPAND software for PC, then tap load to load the configuration onto the K-DUCER control unit.

(2) SAVE programs button

Tap to save the configuration of the K-DUCER control unit, including all program parameters, all sequence parameters, and all general settings, onto the connected USB drive. You will be prompted to enter a name for the configuration file. The file will have a .kdu extension and can be loaded onto this or other K-DUCER units or onto the freely available K-EXPAND software for PC.

(3) UPDATE FIRMWARE button

Tap to update the KDU controller firmware. A confirmation dialog will appear before proceeding. The USB drive connected should contain the appropriate software file for the KDU controller provided by Kolver.

(4) USB drive information

Shows the total space and available space of the connected USB drive, and whether a properly formatted USB drive is connected to the USB type-A connector on the K-DUCER unit.

Note: the unit can store about 300,000 screwdriving results (cycles) for each GB of available space in the USB drive.

(5) Exit button

Tap to exit the USB menu.

FREE K-EXPAND, K-LINK, AND K-GRAPH SOFTWARE

Kolver offers free PC software packages to accompany the K-DUCER series controllers. To download the software, visit www.kolver.com, select “K-DUCER Series” and click the download buttons on the right side., or contact kolver to obtain the setup files.

K-Expand: K-EXPAND is the free software developed by Kolver to set, change, and save all parameters of the K-DUCER control unit.

K-Link: K-LINK is the free software developed by Kolver to automatically store the tightening results from one or more K-DUCER control units, with no user intervention required. K-Link runs as a hidden background Windows service and starts automatically.

K-Graph: K-GRAPH is the free software developed by Kolver to visualize and analyze the torque and angle graphs, starting from a results CSV file or connecting live to a KDU controller via the ethernet or mini-USB port.

Note: Kolver provides an open source library / API for C# available via the NuGet packet manager, as well as a function blocks library for Siemens S7 PLCs (TIA Portal v16 and later), that make the integration via Modbus TCP even easier.

With these Kolver libraries, or with readily available and free third-party Modbus TCP libraries, any entry level programmer can create custom scripts to retrieve data and remote-control the K-Ducer from virtually any ethernet-enabled platform.

Refer to [MODBUS TCP](#).

REMOTE CONTROL INTERFACES

The K-DUCER unit supports the following data acquisition and remote-control interfaces to suit your automation and industry 4.0 needs:

- [24V I/O](#) signals (CN3), providing:
 - remote control (START/STOP/REVERSE and program/sequence selection)
 - angle counting start for [STARTING AT](#) mode “Ext”
 - binary data acquisition (OK/NOK/READY/ERROR/END)

- [MODBUS TCP](#) via ethernet port (CN5), providing:
 - remote control (same functionality as 24V I/O except angle counting start)
 - binary data acquisition (OK/NOK/READY/ERROR/END)
 - full data acquisition of last screwdriving result including torque/angle graphs
 - ability to change any program/sequence/setting parameter
 - connect to K-Graph, K-Expand, and K-Link

- [OPEN PROTOCOL](#) (OP) via ethernet port (CN5), providing:
 - partial remote control (enable/disable tool and program/sequence selection)
 - data acquisition of last screwdriving result
 - ability to change some program/sequence/serial number parameters
 - see [Supported MIDs](#) for more details

- TOOLSNET via ethernet port (CN5), providing connectivity to the ToolsNet software via a modified version of Open Protocol. The ToolsNet PIM server IP and Port must be configured appropriately under the General Settings menu on the controller.

- MiniUSB interface:
 - Connect to K-Graph and K-Expand
 - slower and less featureful than connecting via Modbus TCP
 - ideal if unsure how to set IP addresses for ethernet connection

Also refer to the [Retrieving and storing the screwdriving results](#) section

24V I/O

Introduction

The 24V signals allow start/stop control of the screwdriver, program selection, sequence selection, error detection and clearing, and more.

The advantage of this system is the simplicity of the control, but its disadvantages are:

- Data acquisition capability is limited to OK / NOK signals and end program / end sequence signals. Torque and angle values cannot be read via these I/O signals.
- The 24V signals are susceptible to being disturbed by electromagnetic interference (EMI), especially in the highly noisy electrical environments often found in assembly lines. Kolver recommends using shielded wires with grounded shields and ferrite beads to limit EMI.

For these reasons, Kolver recommends using the more robust ethernet port with MODBUS TCP or Open Protocol whenever possible.

The I/O controls available via CN3 are:

- [I] Actuate the screwdriver motor (START)
- [I] Lock/disable the screwdriver (STOP / PIECE)
- [I] Program selection
- [I] Sequence selection
- [I] Error clearing (ESC)
- [I] Screw, program, or sequence reset (RST)
- [I] End Program / End Sequence acknowledgement (OK)
- [I] Angle counting start
- [O] OK/NOK result
- [O] READY status
- [O] End Program / End Sequence status
- [O] Screwdriver motor status

Pinout (CN3)

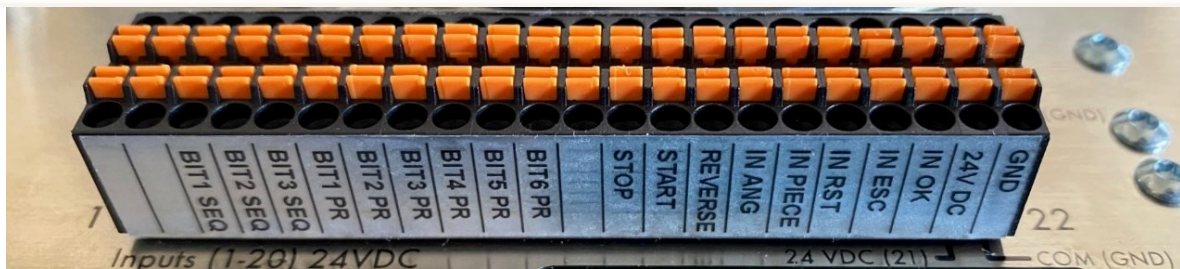
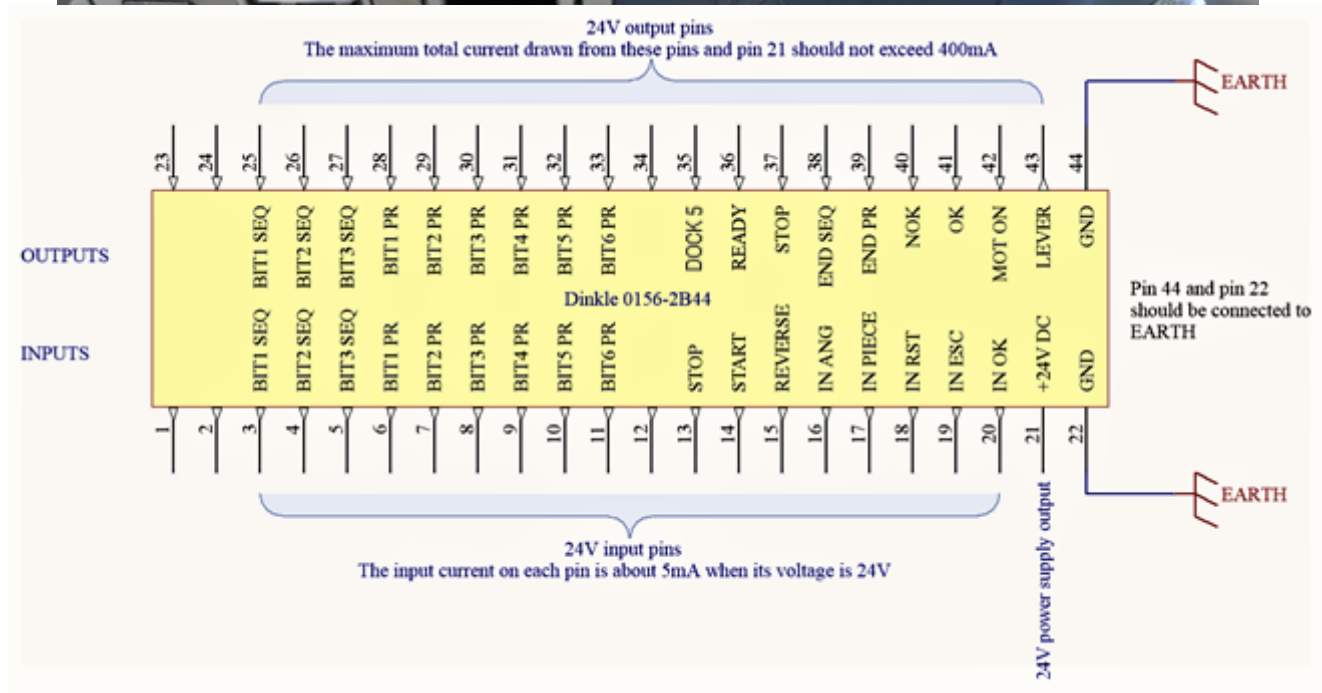
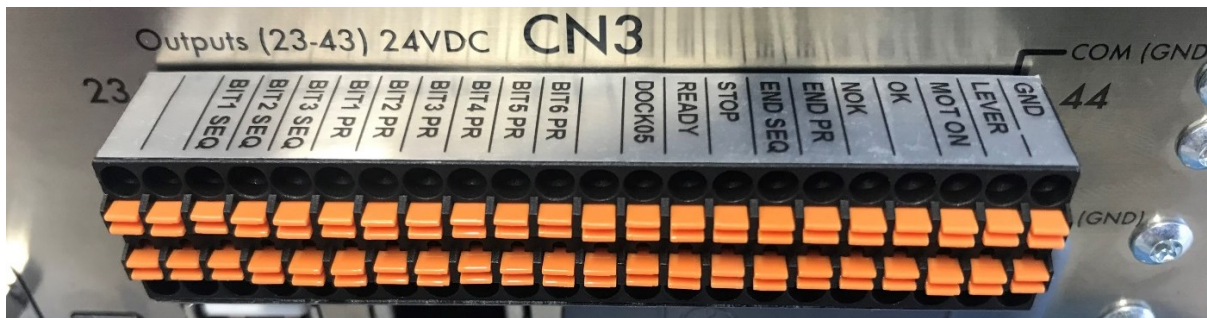

To connect, simply push the cable or the ferrule directly onto the corresponding hole.
To disconnect the cables, press lightly on the respective orange plate.

- Solid cable section min (mm²) 0.2
- Solid cable section max (mm²) 0.5
- Section of braided cable min (mm²) 0.2
- Section of braided cable max (mm²) 0.5
- Flexible cable section with min ferrule without sheath (mm²) 0.25
- Flexible cable section with max ferrule without sheath (mm²) 0.75
- Flexible cable section with min ferrule with sheath (mm²) 0.25
- Flexible cable section with max ferrule with sheath (mm²) 0.5

INPUT SIDE (PINS 1-22)

The input signals must be driven by a +24VDC potential with respect to pin 22 (GND). A +24VDC potential is provided for convenience at pin 21 (24V DC).

When driving the inputs via an automated machine or PLC, it is recommended to program a delay of at least 30ms between each change of input signals.

Pulse signals (IN AGN, IN RST, ESC-EXT, OK-EXT) should be kept active for at least 30ms in order to be properly processed.

PIN	NAME	FUNCTION
1	NOT USED	
2	NOT USED	
3	BIT1 SEQ	Least significant bit to select the Sequence (see charts below)
4	BIT2 SEQ	REMOTE SEQ setting (General Settings > REMOTE SEQ) must be ON to enable sequence selection via input pins 3-4-5
5	BIT3 SEQ	Most significant bit to select the Sequence (see binary tables below)
6	BIT1 PR	Least significant bit to select the Program (see binary tables below)
7	BIT2 PR	REMOTE PR setting (General Settings > REMOTE PR) must be ON to enable program selection via input pins 6-7-8-9-10-11
8	BIT3 PR	
9	BIT4 PR	
10	BIT5 PR	
11	BIT6 PR	Most significant bit to select the Program (see binary tables below)
12	NOT USED	
13	STOP MOTOR	Remote motor stop. When active, the screwdriver stops running and remains disabled. The message "STOP MOTOR ON" appears on the display. This signal disables the screwdriver and is prioritized over any other signal: START and REVERSE signals as well as the physical lever on the screwdriver will be ignored when STOP MOTOR is active. Note: the HIGH/LOW logic of this signal can be inverted via the INVERT LOGIC CN3 PIN 13/17 IN STOP/PIECE setting.
14	START	Remote motor start. This pin serves the same function as the physical lever on the screwdriver. Activating it initiates the screwdriver motor. The signal must be maintained active for the motor to continue running. The motor will continue running until this signal is removed or until the tightening completes according to the current program parameters (for example, when reaching torque). As soon as the tightening completes, the screwdriver motor stops and this signal will be ignored until it is pulled down (for a recommended minimum of 30ms).
15	REVERSE	Remote motor reverse start.

		This pin serves the same function as the physical reverse button on the screwdriver. The behavior of the reverse button can be configured via General Settings > REVERSE BUTTON .
16	IN ANG	Input signal to initiate the angle measurement during a tightening , when using the EXT signal setting for angle measurement (PROGRAM menu > TORQUE & ANGLE > STARTING AT)
17	MISSING PIECE	Same function as pin 13 “STOP MOTOR”, except “Error missing piece” is displayed on the status bar. Typically used in conjunction with a proximity sensor or other part detection mechanism. Note: the HIGH/LOW logic of this signal can be inverted via the INVERT LOGIC CN3 PIN 13/17 IN STOP/PIECE setting.
18	IN RST	This signal serves the same function as the RESET button on the touch screen. The behavior of the RESET button can be configured via General Settings > RESET TYPE . CMD OK-ESC-RESET must be set to EXT or to INT+EXT to enable using this pin (General Settings > CMD OK-ESC-RESET).
19	ESC EXT	This signal serves the same function as the ESC button on the touch screen, to acknowledge and reset errors. Use in conjunction with the PRESS ESC setting on PROGRAMS menu > OTHER > PRESS ESC . CMD OK-ESC-RESET must be set to EXT or to INT+EXT to enable using this pin (General Settings > CMD OK-ESC-RESET).
20	OK EXT	This signal serves the same function as the ESC button on the touch screen, to acknowledge end of program status. Use in conjunction with the PRESS OK setting on PROGRAMS menu > OTHER > PRESS OK . CMD OK-ESC-RESET must be set to EXT or to INT+EXT to enable using this pin (General Settings > CMD OK-ESC-RESET).
21	24 VDC	<u>Must not be used to power external devices (other than PLC blocks)</u> +24V with respect to pin 22 (GND), voltage protected. The maximum current consumption is 400mA. This pin is provided for convenience as a source to activate the input signals. For example, in a typical PLC output terminal block, one can connect the COM(+) pin of the terminal block to this 24VDC source to power the PLC output signals.
22	GND	Common ground for all inputs and outputs, in parallel with pin 44. The input signals must be driven by a +24V potential with respect to this pin (GND). When using an external 24V source to drive the inputs, the negative terminal of the external source must be connected to this pin.

OUTPUT SIDE (PINS 23-44)

The output signals are driven by a +24VDC potential with respect to pin 44 (GND), voltage protected, with a maximum current draw of 400mA.

In a typical PLC input terminal block, the COM(-) pin of the terminal block should be connected to GND pin 44.

The output signals READY, END SEQ, END PR, NOK, and OK, remain active until the screwdriver changes state again, for example, when the operator or the PLC initiates another tightening.

PIN	NAME	FUNCTION
23	NOT USED	
24	NOT USED	
25	BIT1 SEQ	Least significant bit indicating currently selected sequence.
26	BIT2 SEQ	(see binary tables below)
27	BIT3 SEQ	Most significant bit indicating currently selected sequence.
28	BIT1 PR	Least significant bit indicating currently selected program.
29	BIT2 PR	(see binary tables below)
30	BIT3 PR	Note: pins 28-33 will blink when using Kolver CBS or SBX accessories or REMOTE PR with SEQUENCE toggle active.
31	BIT4 PR	
32	BIT5 PR	
33	BIT6 PR	Most significant bit indicating currently selected program.
34	NOT USED	
35	DOCK05	Mirrors 'BIT6 PR', for use with DOCK05 dual screwdriver accessory. This pin does not blink when using Kolver CBS or SBX accessories or REMOTE PR with SEQUENCE toggle active. v34 and later only.
36	READY	This signal is active when the screwdriver is in stand-by, ready to receive the START or REVERSE input commands.
37	STOP	This signal is active when the screwdriver is in STOP MOTOR state. Note that entering the configuration menu on the touch screen puts the screwdriver in the STOP MOTOR state.
38	END SEQ	This signal is active when the currently selected sequence completes, in other words, when the last screw of the last program in the sequence is tightened successfully (with OK result). This signal remains active until the screwdriver changes state again, for example, when the operator or the PLC initiates another tightening.
39	END PR	This signal is active when the currently selected program completes, in other words, when the last screw of the program is tightened successfully (with OK result). This signal will not activate if the "number of screws" setting of the program is zero.

40	NOK	(Not-OK) This signal activates when the tightening (screw) completes unsuccessfully, outside of the parameters set for the current program, for example: torque reached under minimum time, torque reached outside angle bounds, etc. This signal remains active until the screwdriver changes state again, for example, when the operator or the PLC initiates another tightening.
41	OK	This signal activates when the tightening (screw) completes successfully and within the parameters set for the current program. This signal remains active until the screwdriver changes state again, for example, when the operator or the PLC initiates another tightening.
42	MOTOR ON (/W)	It activates when the screwdriver is tightening. Note: this signal does not activate when the screwdriver is reversing, it is intended for use with auto-advancing fixtures and arms.
43	LEVER	It activates when the screwdriver lever is pressed.
44	GND	Common ground for all inputs and outputs, in parallel with pin 22. The 24V output signals must be taken between the output pin of interest and this ground pin. In a typical PLC input terminal block, the COM(-) pin of the terminal block should be connected to GND pin 44.

Wiring diagrams

Inputs (pins 1-20)

All inputs (Pins 1 to 20) of the CN3 connector require a 24V DC positive signal. The signals can be powered via an external 24VDC source, in which case the negative terminal of the source should be connected to pin 22, or via pin 21 (internal 24VDC), in which case the contact can be controlled with opto-isolator, relay or button to activate the desired input.

Example on how to enable Input signals using an external source:

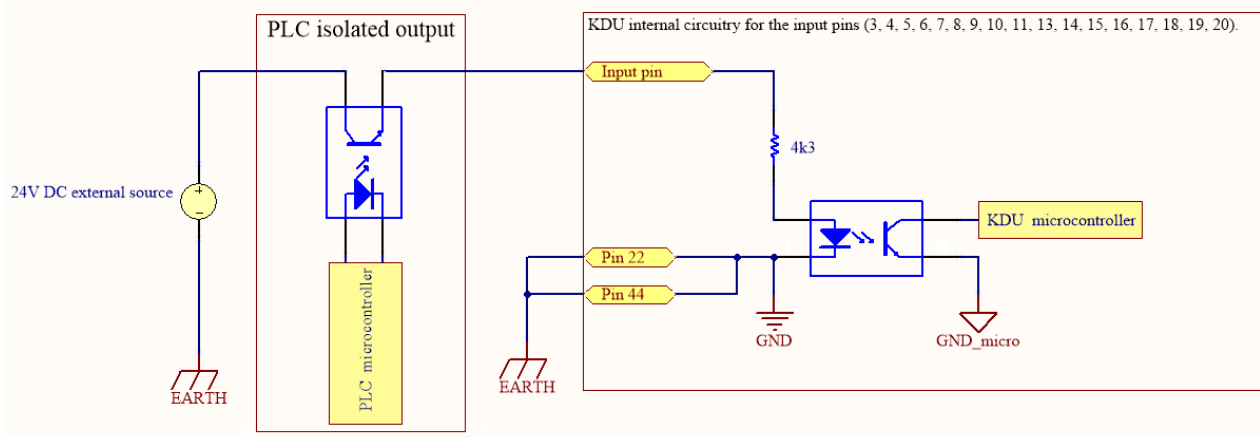

Example on how to enable Input signals using the internal tension on Pin 21:

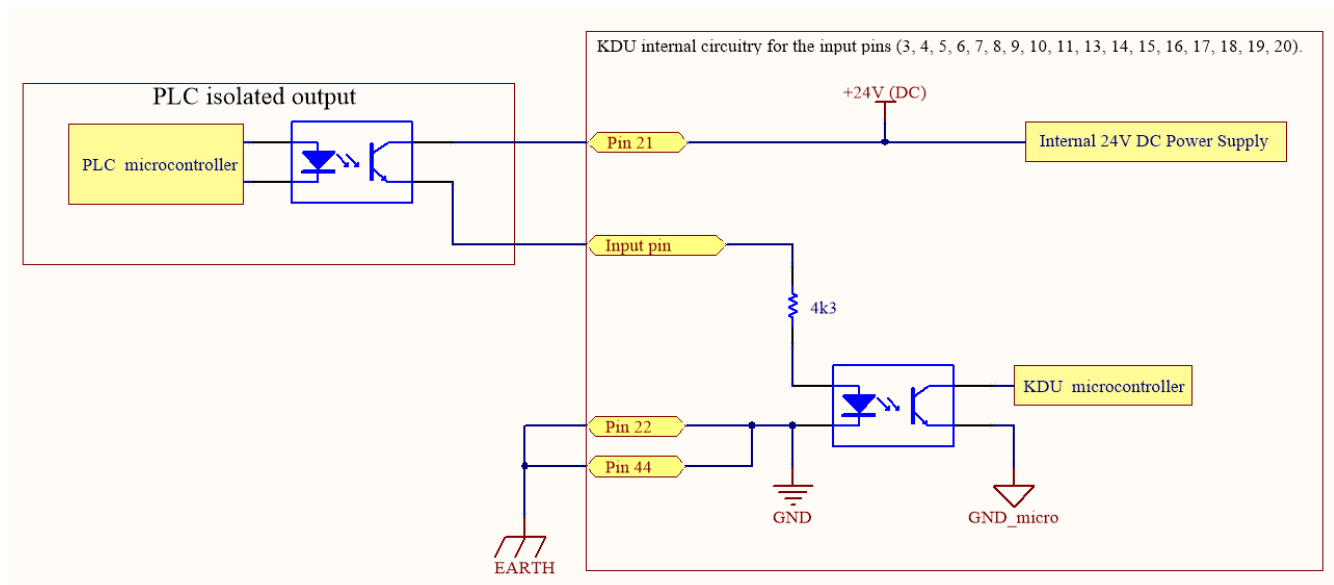

Outputs (pins 23-43)

When active, an output pin will provide a 24V DC signal on the respective pins with respect to ground pins 22/44. The signals can be used to activate LEDs / sensors or read directly from an external PLC. In this case the negative terminal of the KDU unit (pins 22 / 44) must be connected with the negative terminal of the PLC terminal block. The total power of the output signals is Max 400mA; if exceeded, a protection circuit deactivates the output signals and activates an alarm on the display (see figure below). The alarm signal remains active until the power draw drops below the 400mA threshold, which is checked every 2 seconds.

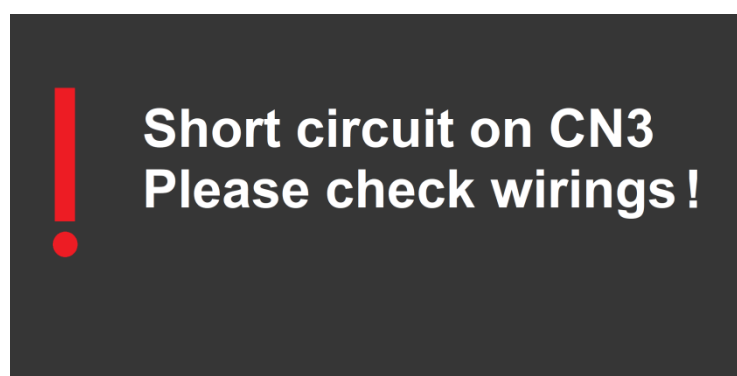

KDU internal circuitry for the output pins (25, 26, 27, 28, 29, 30, 31, 32, 33, 37, 38, 39, 40, 41, 42, 43).

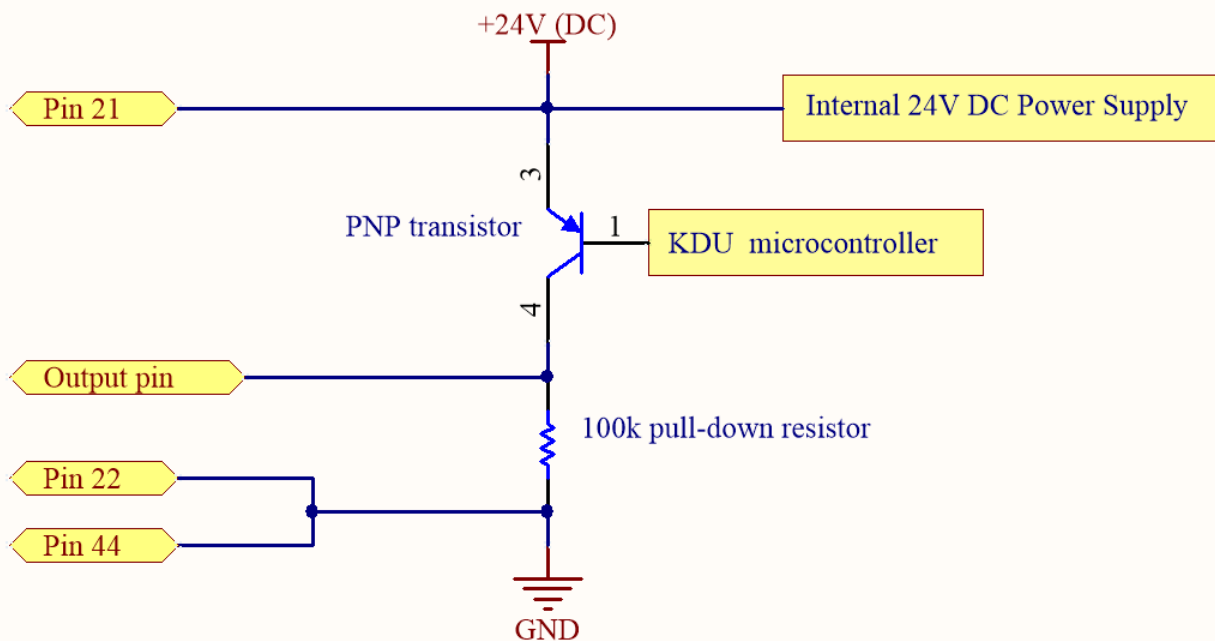

Sequence and program selection via 24V I/O on CN3

Refer to the tables below for sequence or program selection via CN3, where “1” refers to an active +24VDC signal with respect to the GND pin and “0” refers to no signal.

The REMOTE PR or REMOTE SEQ setting (General Settings > [REMOTE PR](#) and [REMOTE SEQ](#)) must be active for the input selection to work.

The selection mode depends on the [CN3 BITx IN PIN MODE](#) setting (General Settings screen). Default is binary. The non-binary selection modes are only available with KDU software v39 and later.

Binary mode (default)

The outputs pins 25-33 will always be active irrespective of the REMOTE PR/SEQ setting, following the same binary code pattern for the input side reported below.

Sequence	BIT3 SEQ PIN 5	BIT2 SEQ PIN 4	BIT1 SEQ PIN 3
-	0	0	0
A	0	0	1
B	0	1	0
C	0	1	1
D	1	0	0
E	1	0	1
F	1	1	0
G	1	1	1
H	Not Selectable		

PR #	BIT6PR PIN11	BIT5PR PIN10	BIT4PR PIN9	BIT3PR PIN8	BIT2PR PIN7	BIT1PR PIN 6	PR #	BIT6PR PIN11	BIT5PR PIN10	BIT4PR PIN9	BIT3PR PIN8	BIT2PR PIN7	BIT1PR PIN 6
-	0	0	0	0	0	0	32	1	0	0	0	0	0
1	0	0	0	0	0	1	33	1	0	0	0	0	1
2	0	0	0	0	1	0	34	1	0	0	0	1	0
3	0	0	0	0	1	1	35	1	0	0	0	1	1
4	0	0	0	1	0	0	36	1	0	0	1	0	0
5	0	0	0	1	0	1	37	1	0	0	1	0	1
6	0	0	0	1	1	0	38	1	0	0	1	1	0
7	0	0	0	1	1	1	39	1	0	0	1	1	1
8	0	0	1	0	0	0	40	1	0	1	0	0	0
9	0	0	1	0	0	1	41	1	0	1	0	0	1
10	0	0	1	0	1	0	42	1	0	1	0	1	0
11	0	0	1	0	1	1	43	1	0	1	0	1	1
12	0	0	1	1	0	0	44	1	0	1	1	0	0
13	0	0	1	1	0	1	45	1	0	1	1	0	1
14	0	0	1	1	1	0	46	1	0	1	1	1	0
15	0	0	1	1	1	1	47	1	0	1	1	1	1
16	0	1	0	0	0	0	48	1	1	0	0	0	0
17	0	1	0	0	0	1	49	1	1	0	0	0	1
18	0	1	0	0	1	0	50	1	1	0	0	1	0
19	0	1	0	0	1	1	51	1	1	0	0	1	1
20	0	1	0	1	0	0	52	1	1	0	1	0	0
21	0	1	0	1	0	1	53	1	1	0	1	0	1
22	0	1	0	1	1	0	54	1	1	0	1	1	0
23	0	1	0	1	1	1	55	1	1	0	1	1	1
24	0	1	1	0	0	0	56	1	1	1	0	0	0
25	0	1	1	0	0	1	57	1	1	1	0	0	1
26	0	1	1	0	1	0	58	1	1	1	0	1	0
27	0	1	1	0	1	1	59	1	1	1	0	1	1
28	0	1	1	1	0	0	60	1	1	1	1	0	0
29	0	1	1	1	0	1	61	1	1	1	1	0	1
30	0	1	1	1	1	0	62	1	1	1	1	1	0
31	0	1	1	1	1	1	63	1	1	1	1	1	1
PR #	BIT6PR PIN11	BIT5PR PIN10	BIT4PR PIN9	BIT3PR PIN8	BIT2PR PIN7	BIT1PR PIN 6	PR #	BIT6PR PIN11	BIT5PR PIN10	BIT4PR PIN9	BIT3PR PIN8	BIT2PR PIN7	BIT1PR PIN 6

Note: for safety reasons, Kolver has chosen not to associate any program or sequence if no input is activate. This makes sequence H and program 64 not selectable via CN3 inputs. It is still possible to select sequence H or program 64 manually, with Kolver accessories, or via one of the communication protocols.

Discrete mode

A single input determines the selection of the program (or sequence):

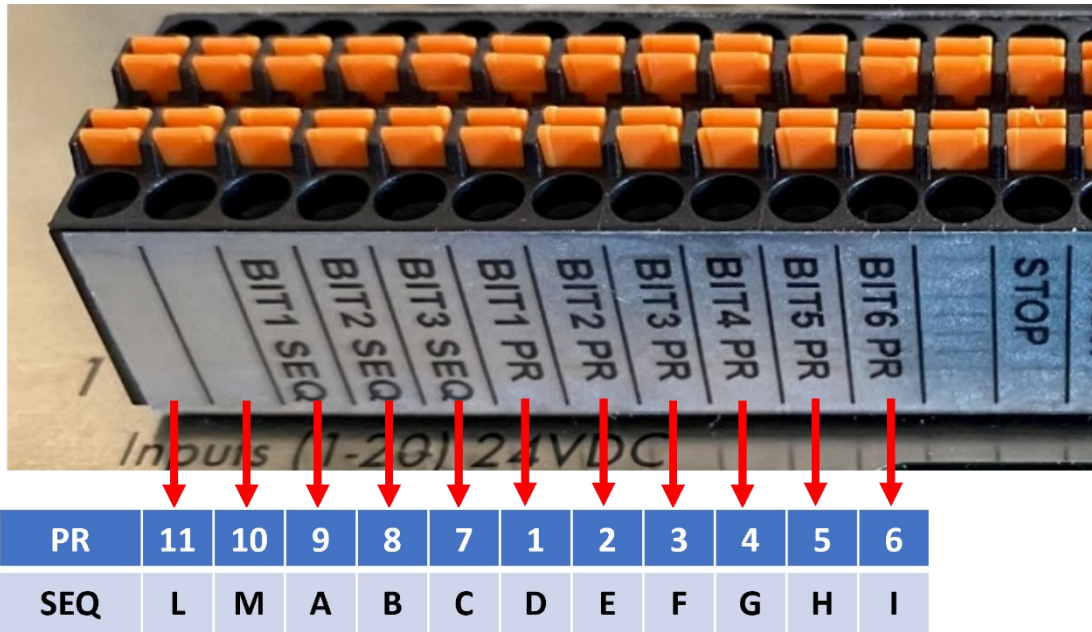

PNP sens X mode

This mode is designed for Kolver accessory 020043, or PNP proximity sensors for bit selection, intended to be used with a robot or automatic machine.

The number after the X stands for the number of sensors being used, two to six.

X + 1 programs can be selected in this mode.

The brown positive wire of each PNP sensor must be wired to the +24VDC source (PIN 21).

The blue negative wire of the each PNP sensor must be wired to GND (PIN 22).

The black signal wire of the first sensor must be wired to BIT1 PR.

The black signal wire of the second sensor must be wired to BIT2 PR.

And so on, each additional sensor should be wired to the next available BITxPR.

When both proximity sensors are active, indicating proximity, program X + 1 will be selected. This program is intended to contain the parameters for picking up the bit (minimum speed recommended and low torque).

When only one proximity sensor is negative, indicating no proximity (bit removed), the program corresponding to the BITxPR wired to the indicating sensor is selected.

When more than one proximity sensors is negative, indicating more than one bit removed, the “No program selected” screen will appear.

For example:

CN3 BITx IN MODE set to “pnp sens x3”:

Three brown PNP sensor wires will go to PIN 21 (+24VDC), three blue PNP sensor wires will go to GND (PIN 22), then one black wire from each sensor will go into BIT1PR, BIT2PR, and BIT3PR.

When no bits are removed, program number 4 is selected.

When **only** bit of sensor 2 (wired to BIT2PR) is removed, program 2 is selected (and likewise for only bit 1 or bit 3 removed).

When more than one bit is removed, no programs are selected (invalid selection).

MODBUS TCP

The recommended way to interface with the K-DUCER unit is through the MODBUS TCP protocol on the ethernet port (CN5).

MODBUS communication protocol provides a Client-Server interface between devices connected on an ethernet TCP/IP network.

The MODBUS protocol specifications are open source and freely available online at modbus.org, however most automation engineers will not need to worry about the implementation details because MODBUS is already supported and implemented by most ethernet-capable PLCs and industrial PCs.

We provide a detailed instructions manual as well as sample projects for various devices illustrating how to use Modbus TCP to retrieve torque data and/or remote control the screwdriver. Simply download the “Modbus TCP Resources” packet from our website at <https://kolver.com/us/products/kducer-series>

These examples can be used as provided or as a starting point for in-house software development.

Additionally, Kolver provides an open source library for C# available via the NuGet packet manager, as well as a function blocks library for Siemens S7 PLCs (TIA Portal v16 and later).

Kolver’s automation engineers are also available to support with your integration.

ADFWeb, Anybus, Rockwell, Allen Bradley, MicroPLC, ControlLogix, CompactLogix, Siemens, SIMATIC, Universal Robots, PolyScope, are all trademarks of their respective corporations and are not affiliated with Kolver.

OPEN PROTOCOL

Introduction

The K-DUCER control unit supports a subset of the Open Protocol communication interface, based on a combination of the Open Protocol specifications 2.8.0 and 1.6.3. The Open Protocol communication interface gives the K-DUCER plug-and-play compatibility with any MES software (Manufacturing Execution System) that supports Open Protocol 2.8 or 1.6.

Enable Open Protocol via the General Settings menu > [COMMUNICATION PROTOCOL](#), selecting "OP". Open Protocol works on TCP/IP port 4545.

Terminology

Open Protocol	K-DUCER
Pset (Parameter set)	Program (numbered 1 through 200)
Batch size	Number of screws (configured for each program, default 1, max 99)
Job	Sequence of up to 32 programs. Sequences are identified as letters in the KDU controller, but as numbers (Job IDs) in Open Protocol. The Sequence-Job ID association is: A = 1, B = 2, C = 3, [...], X = 24
VIN	Barcode (for barcode mode "on S/N" only)

Supported MIDs

MID	Description	Revision(s)	Sent by	Response MID
0001	Communication Start	001 – 006	Integrator	0002 or 0004
0002	Communication Start Acknowledge	001 – 006	Controller	None
0003	Communication Stop	001	Integrator	0005
0004	Command Error	001	Controller	None
0005	Command Accepted	001	Controller	None
0006	Application data message request	001	Integrator	Varies
0008	Application data message subscription	001	Integrator	0005 or 0004
0009	Application data message unsubscribe	001	Integrator	0005
0010	Pset Id upload request	001	Integrator	0011
0011	Pset Id upload reply	001	Controller	None
0012	Pset data upload request	001	Integrator	0013 or 0004
0013	Pset data upload reply	001	Controller	None
0014	Pset selected subscribe	001, 002	Integrator	0005 and 0015
0015	Pset selected	001, 002	Controller	0016
0016	Pset selected acknowledge	001	Integrator	None
0017	Pset selected unsubscribe	001	Integrator	0005 or 0004
0018	Select Pset	001	Integrator	0005 or 0004
0019	Set Batch Size	001	Integrator	0005 or 0004

0020	Reset Batch Counter	001	Integrator	0005 or 0004
0030	Job ID upload request	001	Integrator	0031
0031	Job ID upload reply	001	Controller	None
0032	Job data upload request	001	Integrator	0033 or 0004
0033	Job data upload reply	001	Controller	None
0034	Job info subscribe	001	Integrator	0005 or 0004
0035	Job info	001	Controller	None or 0036
0036	Job info acknowledge	001	Integrator	None
0037	Job info unsubscribe	001	Integrator	0005 or 0004
0038	Select Job	001	Integrator	0005 or 0004
0039	Job restart	001	Integrator	0005 or 0004
0040	Tool data upload request	001	Integrator	0041
0041	Tool data upload reply	001	Controller	None
0042	Disable tool	001	Integrator	0005
0043	Enable tool	001	Integrator	0005
0050	Vehicle ID Number download request	001	Integrator	0005 or 0004
0051	Vehicle ID Number subscribe	001	Integrator	0005 or 0004
0052	Vehicle ID Number	001	Controller	0053
0053	Vehicle ID Number Acknowledge	001	Integrator	None
0054	Vehicle ID Number Unsubscribe	001	Integrator	0005 or 0004
0060	Last tightening result data subscribe	001 – 006	Integrator	0005 or 0004
0061	Last tightening result data	001 – 006	Controller	None or 0062
0062	Last tightening result data acknowledge	001 – 006	Integrator	None
0063	Last tightening result data unsubscribe	001 – 006	Integrator	0005 or 0004
0070	Alarm subscribe	001	Integrator	0005 or 0004
0071	Alarm	001	Controller	None or 0072
0072	Alarm acknowledge	001	Integrator	None
0073	Alarm unsubscribe	001	Integrator	0005 or 0004
0080	Read time upload request	001	Integrator	0081
0081	Read time upload reply	001	Controller	None
0082	Set time	001	Integrator	0005
0113	Flash Green Light*	001	Integrator	0005 or 0004
0127	Abort Job	001	Integrator	0005 or 0004
0130	Job Off	001	Integrator	0005 or 0004
0900	Trace curve data message	001	Controller	0005
2500	Tightening Program Message download**	001	Integrator	0005 or 0004
2500	Tightening Program Message upload**	001	Controller	None
MID	Description	Revision(s)	Sent by	Response MID

*the **Flash Green Light** mid 0113 is implemented for MES compatibility and has no effect.

Note: the **Job Off** mid 0130 can be used to both activate and deactivate Sequence Mode (Job Mode).

**see special instructions below for MID 2500 and MID 2501

MID 2500 instructions

MID 2500 allows modifying tightening program parameters for any program (pset).

To provide easier interoperability with existing systems, each program parameter that can be modified via this MID can be accessed via two or more PID (parameter ID):

- one corresponds to the closest equivalent function found in the Open Protocol PID list
- another corresponds to a unique ID specific to the KDU-1A, starting at PID 60000

The following limitations apply to the use of MID 2500 with a Kolver KDU-1A controller:

- The table below lists the only PID, value lengths, and units supported for each PID (example MIDs are provided after the table).
- The only node type supported is 001 or 100 with no distinction between the two
- JSON mode for program data is not supported.
- Children nodes are not supported. Send the entire PID list as a single flat node. The step number field in each PID is ignored.
- PID 01000 (61000) “Tightening program number”, if sent, must be the first
- PID 60000 “MID programming mode”, if sent, must be the first if PID 01000 is not being used, or the second if PID 01000 is being used. This PID determines whether to reset the program number (specified by PID 01000 or the current program) to default values and if so, for which screwdriver model.
- You do not need to send all PID parameters with MID 2500, only the ones that you intend to modify. See usage of special PIDs 01000 (61000) and 60000 for how to modify a program in-place or reset unused parameters to valid default settings
- The parameter changes are saved in volatile memory and are lost when power cycling the controller
- Processing MID 2500 takes approximately 50-100ms
- The integrator assumes full responsibility for the validity of the data being sent. Some limited data validation is done when processing MID 2500, and the system still checks for invalid parameter combinations after saving the new parameters (i.e. torque target above maximum torque), but this should not be relied upon for safety.
- It is best practice to disable the tool (MID 0042) before sending MID 2500.
- If the screwdriver is running and/or if the screwdriver trigger is being pressed, MID 2500 will be refused.
- If the controller is on any configuration menu screen, MID 2500 will be refused.

Special **PID** instructions:

PID 01000 (61000) "Tightening program number"

Determines the program number to modify. If not sent, the current program will be modified. If sent, it must be the first.

PID 60000 "MID 2500 programming mode"

Determines whether to reset the program number (specified by PID 01000 or the current program) to default values and if so, for which screwdriver model (specified by the data value). If sent, it must be the first if PID 01000 is not being sent, or the second if PID 01000 is being sent.

The default values are:

Torque&Angle mode: torque control with angle monitoring

Torque target: 1.2 Nm

Torque max and Reverse torque: the max torque of the tool specified

Torque min and angle min: zero

Angle max: 30000 degrees

Angle target: 180 degrees (note this is not used in torque control mode)

Angle count mode: starting at torque threshold

Angle count "starting at" threshold: zero Nm (angle count starts immediately)

Reverse speed: the max speed of the tool specified

Final speed: the lower of 100 RPM or twice the minimum speed of the tool specified

Downshift mode: on with torque threshold 0.6 Nm

Downshift (initial) speed: the lower of 600 RPM or the max speed of the tool specified

Reverse allowed ON

Release lever error ON

Number of screws: 1

All other settings are set to OFF or zero

PID 01002 (61002) "Control Tightening program Strategy"

This setting only affects the Torque & Angle mode.

In the KDU-1A, values 01 and 02 are the same; 03 and 04 are the same, for 03 (sequential torque and angle control aka "turn of the nut") you need to set the "Angle starting at" parameter which becomes the initial torque target before angle control mode begins)

Prevailing torque monitoring and compensation modes are a separate setting. When using a PVT Compensate mode, the torque target becomes the clamping torque target.

01=Torque control = 02=Torque control / angle monitoring

03=Torque control / angle control AND = 04=Angle control / torque monitoring

Note: torque target is ignored for modes 3 and 4, angle target is ignored for modes 1 and 2

PID 02076/7 (62076/7) “Prevailing Torque / Running Torque Mode”

The value determines the different combinations available in the KDU-1A:

- 0 = off
- 1 = compensate, time window, average value
- 2 = compensate, time window, peak value
- 3 = compensate, angle window, average value
- 4 = compensate, angle window, peak value
- 5 = monitor, time window, average value
- 6 = monitor, time window, peak value
- 7 = monitor, angle window, average value
- 8 = monitor, angle window, peak value

Data types and Unit Types tables

For reference, the supported units and data types are provided here:

Characters sent in telegram	Type	Description
01	UI	The value is an unsigned integer. The number of digits are defined with the Length parameter
04	S	The value is a string. Sent as ASCII characters, the length of the data fits the actual length of the string. Note that the string may contain spaces (ASCII character 0x20). There is no need to include a NUL terminator, and if you include it, it must be accounted for in the length.
06	B	A boolean value, one ASCII digit, 0 = FALSE and 1 = TRUE

B and UI types are interchangeable when the actual value is 0 or 1.

Floats are not supported. Send all torque values in mNm or cNm.

The measurement units selected in the KDU-1A general settings are independent and have no bearing on the measurement units used to send PID values.

Characters sent in telegram	Unit
000	no unit (ignored, not enforced for PIDs with no units)
003	cNm (centinewton meter)
012	mNm (millinewton meter)
050	degrees (angle)
101	RPM
202	milliseconds

Table of PIDs for MID 2500

Note: step number is ignored but must be included, per Open Protocol specifications.

You can use either PID (1) or PID (2).

Open Protocol PID Name	Kolver program parameter name	PID (1)	PID (2)	Length of data value	Data type	Unit	Data value or possible values
Tightening program Number	Program number	01000	61000	1 to 3	UI	000	1 to 200
N/A	MID programming mode	N/A	60000	1	UI	000	0 = no effect, same as not sending this PID at all 1 = KDS-PL6, 2 = KDS-PL10, 3= KDS-PL15, 4 = KDS-MT15, 5 = KDS-PL20, 6 = KDS-PL30, 7 = KDS-PL35, 8 = KDS-PL45, 9 = KDS-PL50, 10 = KDS-PL70, 11 = KDS-PL3
Batch size	Number of screws	00100	60100	1 to 3	UI	000	0 to 999 0 = screw counting off
Tightening program Name	Program description	01001	61001	1 to 30	S	000	ASCII characters. Number of chars must equal the Length provided.
Control Tightening program Strategy	Torque&Angle Mode	01002	61002	1 to 2	UI	000	1 to 4, see special instructions
Max Coherent NOK	Lock after consecutive NOK	01020	61020	1 to 2	UI	000	0 to 99
Options Used	N/A	01026	61026	1	UI or B	000	value is ignored, provided for compatibility only
Options Lost trigger detect	Lever error	01030	61030	1	UI or B	000	0 or 1
Disable loosening	Reverse allowed (inverted)	01043	61043	1	UI or B	000	0 or 1
Torque, final target	Torque target	02000	62000	1 to 5	UI	003 or 012	1 to 70000
Torque, final upper limit	Torque max	02002	62002	1 to 5	UI	003 or 012	1 to 70000
Torque, final lower limit	Torque min	02003	62003	1 to 5	UI	003 or 012	0 to 70000
Torque, first target	Downshift threshold torque value	02004	62004	1 to 5	UI	003 or 012	0 to 70000
Angle, target	Angle target	02010	62010	1 to 5	UI	050	1 to 30000
Angle, upper limit	Angle max	02012	62012	1 to 5	UI	050	1 to 30000
Angle, lower limit	Angle min	02013	62013	1 to 5	UI	050	0 to 30000
Angle target threshold torque cycle start	Angle starting AT	02014	62014	1 to 5	UI	003 or 012	0 to 70000
Angle target threshold torque cycle end	Angle starting AT	02015	62015	1 to 5	UI	003 or 012	0 to 70000
Speed, target	FINAL speed	02050	62050	1 to 4	UI	101	10 to 1800
Step Speed	Downshift (INITIAL) speed	02052	62052	1 to 4	UI	101	10 to 1800

Soft start time	Ramp	02054	62054	1 to 4	UI	202	0 to 3000
Lock at batch done	Press OK	02058	62058	1	B or UI	000	0 or 1
Rotate Direction	Rotation	02060	62060	1	UI	000	1 = CW, 2 = CCW
Prevail Torque Max	PVT/RT Max	02072	62072	1 to 5	UI	003 or 012	1 to 70000
Prevail Torque Min	PVT/RT Min	02073	62073	1 to 5	UI	003 or 012	0 to 70000
Prevail	Prevailing/Running torque mode	02076	62076	1	B or UI	000	0 to 8 0 = off See special instructions
		02077	62077				
Prevail Torque Delay Interval	Prevailing torque window start	02085	62085	1 to 5	UI	050 or 202	0 to 30000 this is the PV/RT window START, in time or angle. The START and END must both use time or both use angle and be coherent with the PVT mode selected with PID 02076/7 (62076/7)
Prevail Torque Monitor Interval	Prevailing torque window duration (window end = start + duration)	02086	62086	1 to 5	UI	050 or 202	0 to 30000 this is the PV/RT window DURATION. In the KDU-1A, you normally enter the START and END, not the DURATION. To conform to Open Protocol, enter this value as the DURATION. The END parameter is calculated by the controller as the sum of START and DURATION.
Loosening limit torque	Reverse torque	02100	62100	1 to 5	UI	003 or 012	1 to 70000
Loosening speed	Reverse speed	02101	62101	1 to 4	UI	101	10 to 1800
Speed unit	N/A	02103	62103	1	B or UI	000	value is ignored, provided for compatibility only
Elapsed time	Max time	02170 or 01019	62170 or 61019	1 to 5	UI	202	0 to 20000
Open Protocol PID Name	Kolver program parameter name	PID (1)	PID (2)	Length of data value	Data type	Unit	Data value or possible values

MID 2500 Examples

Legend:

HEADER----- = MID header

Nod = Node type

Num = Number of PID in MID

PID-- = the PID code

Len = the PID value length

Dt = the data type of the PID value

Unt = the units of the PID value if applicable

Step = the step number, always 0000 or ignored for KDU-1A

V = the PID value

Cc = number of children (must be zero for KDU-1A)

Note: spaces are swapped with tildes (~) for clarity. In a real message, use spaces

final NUL character is not shown but must be included

The MID below modifies program 5 and resets it to the default values for KDS-MT1.5 (number 4). You can also use PID 61000 instead of PID01000 for the same result.

```
006425000010~~~~00~~00100201000001010000000560000001010000000400
HEADER-----NodNumPID--LenDtUntStepVPID--LenDtUntStepVCc
```

The MID below resets the parameter values of whichever program is currently selected (because no PID 01000 is provided) to the default values for KDS-PL15 (number 3):

```
004625000010~~~~00~~00100160000001010000000300
HEADER-----NodNumPID--LenDtUntStepVCc
```

The MID below sets the torque target, torque max, torque min, reverse torque of the currently selected program to respectively 100 cNm, 1050 mNm, 10 cNm, 2000 mNm; and sets the program name (description) to “modified from mid”:
Note node type 100 is equivalent to 001. These parameters can be sent in any order.

```
014325000010~~~~00~~10000502000003010030000100020020040101200001050
HEADER-----NodNumPID--LenDtUntStepV--PID--LenDtUntStepV---
(continued)
020030020100300001002100004010120000200001001017040000000modified~
PID--LenDtUntStepV-PID--LenDtUntStepV---PID--LenDtUntStepV-----
(continued)
from~mid00
-----Cc
```

Set the reverse speed of the current program to 600 RPM:

```
004825000010~~~~00~~0010016210100301101000060000
HEADER-----NodNumPID--LenDtUntStepV--Cc
```

Set running torque mode 5 (time, comp, avg), window 300 – 700ms (700 sent as 400 duration), min-max 355-1655 mNm:

```
012725000010~~~~00~~00100562076001010000000562085003012020000300620
HEADER-----NodNumPID--LenDtUntStepVPID--LenDtUntStepV--PID
(continued)
860030120200004006207300301012000035562072004010120000165500
--LenDtUntStepV--PID--LenDtUntStepV--PID--LenDtUntStepV---Cc
```

TOOLSNET OPEN PROTOCOL

To connect the K-Ducer to your ToolsNet installation via the ToolsNet Open Protocol:

1. Select the “OP + ToolsNet” [COMMUNICATION PROTOCOL](#) (general settings menu)
2. Assign a static IP address, gateway, and subnet mask to the K-Ducer, compatible with the LAN network where the ToolsNet Server operates
3. Enter the ToolsNet Server PIM service IP address and port on the [TOOLSNET SETTINGS](#) menu (general settings menu).

Tightening results and torque vs angle graphs will be reported to the ToolsNet software.

PROFINET / Ethernet IP / EtherCAT / others

Virtually all ethernet-enabled PLCs used in industry are capable of communication via MODBUS TCP and come with ready-to-use MODBUS TCP libraries and/or function blocks.

This is confirmed by countless customers using Allen Bradley (Rockwell), Siemens S7, Schneider Modicon, and Omron N series PLCs, networked directly to KDU-1A controllers via Modbus TCP.

Kolver also provides a library for Siemens S7 PLCs (TIA Portal v16 or later) with pre-built function blocks to execute the commonly used remote control and data retrieval functions for KDU-1A controllers.

For those customers requiring or preferring to communicate or control the K-DUCER directly using other communication protocols such as PROFINET, Ethernet IP, or EtherCAT, Kolver recommends purchasing a protocol converter such as [ADFWeb protocol converters](#) , Anybus x-gateway converters, or similar devices.

For example:

PROFINET converters: Anybus AB9007, Moxa MGate 5103, ADFWeb HD67611-A1

ETHERNET/IP converters: Anybus AB9006, Moxa 50105-MB-EIP, ADFWeb HD67664-A1

Kolver can provide support in configuring these products, but recommends working directly with the Modbus TCP capabilities of the PLC.

ADFWeb, Anybus, Rockwell, Allen Bradley, MicroPLC, ControlLogix, CompactLogix, Siemens, SIMATIC, Universal Robots, PolyScope, are all trademarks of their respective corporations and are not affiliated with Kolver.

COLLABORATIVE ROBOTS

Kolver provides a URCap for plug-and-play functionality with Universal Robots (both CB3 and e-series) without needing to configure any communication protocol settings (other than assigning an IP address and selecting the Modbus TCP protocol on the KDU unit).

Plugins for other brands of collaborative robots are also being developed.

MAINTENANCE AND CARE

INTRODUCTION

K-DUCER and KDS screwdrivers are precision tools. While built to withstand heavy use in industrial environments, good care and proper maintenance will go a long way in ensuring the best performance and lifetime of your instrument.

Make sure to follow the [INSTALLATION](#) instructions for the K-DUCER, KDS screwdriver, and the reaction arm.

The most important factor in ensuring long-lasting performance and lifetime of the instrument is to configure it properly for the job required. Read this manual carefully to ensure the tool is optimally configured for your application.

Some factors that can overwork and overheat the screwdriver include:

- Combination of high torque and low speed on very elastic joints (note that the screwdriver delivers high torques more efficiently at higher speeds)
- Very high duty cycles (< 3 seconds between tightenings), depending on the difficulty (torque, elasticity, speed) of the tightening
- High torques are defined as above 80% of the maximum nominal torque for the KDS screwdriver model. Consider upsizing to a higher-torque screwdriver model if most of your cycles are above 80% of the maximum nominal torque.

CALIBRATION

Recommended calibration interval: every 500,000 cycles. See [TOOL INFO](#) to check the number of cycles of your KDS screwdriver.

Kolver supplies all KDS series screwdrivers with the transducer pre-calibrated on a semi-elastic joint at a final speed of 100RPM (KDS models 15Nm and smaller) or 50RPM (KDS models 20Nm and larger). The calibration settings are unique to each KDS screwdriver and saved on the KDS screwdriver board.

Contact your Kolver representative to schedule a maintenance and calibration service with Kolver or through one of our ISO/NIST certified lab partners.

Alternatively, Kolver can provide calibration instructions for you to perform the calibration in-house.

MAINTENANCE

Recommended maintenance interval: every 500,000 cycles. See [TOOL INFO](#) to check the number of cycles of your KDS screwdriver.

Maintenance consists of disassembling the screwdriver to clean and relubricate the gearbox, and checking the calibration of the screwdriver against a certified torque measurement tool. Contact your Kolver representative to schedule a maintenance service. Alternatively, Kolver can provide maintenance instructions.

GUARANTEE

This KOLVER product is guaranteed against defective workmanship or materials, for a maximum period of 12 months following the date of purchase from KOLVER, provided that its usage is limited to single shift operation throughout that period. If the usage rate exceeds of single shift operation, the guarantee period shall be reduced on a prorata basis. If, during the guarantee period, the product appears to be defective in workmanship or materials, it should be returned to KOLVER or its distributors, transport prepaid, together with a short description of the alleged defect. KOLVER shall, at its sole discretion, arrange to repair or replace free of charge such items.

This guarantee does not cover repair or replacement required as a consequence of products which have been abused, misused or modified, or which have been repaired using not original KOLVER spare parts or by not authorized service personnel.

KOLVER accepts no claim for labour or other expenditure made upon defective products. Any direct, incidental or consequential damages whatsoever arising from any defect are expressly excluded.

This guarantee replaces all other guarantees, or conditions, expressed or implied, regarding the quality, the marketability or the fitness for any particular purpose.

No one, whether an agent, affiliate or employee of KOLVER, is authorized to add to or modify the terms of this limited guarantee in any way. However it's possible to extend the warranty with an extra cost. Further information at kolver@kolver.it.