

ARL1 Series Piston Pumps

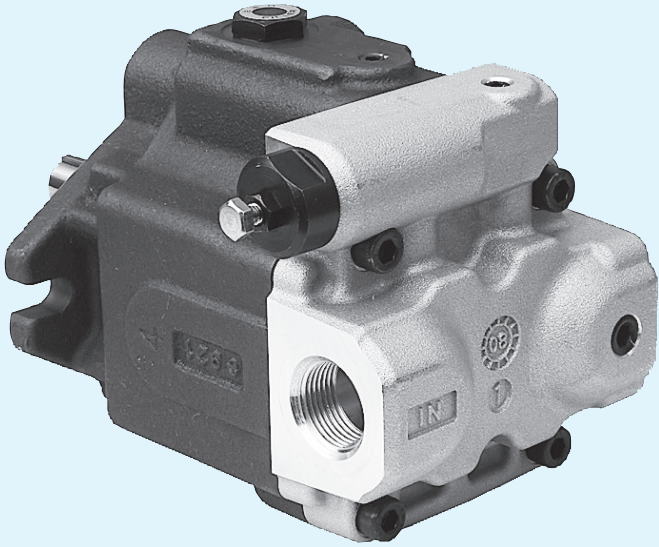

■ “ARL1” Series Piston Pumps

Pump Type	Graphic Symbol	Geometric Displacement cm ³ /rev						Maximum Operating Pressure MPa	Page		
		1	2	5	10	20	50			100	150
ARL1 Series Piston Pump				ARL1-6					7	A-6	
				ARL1-8							
				ARL1-12							
				ARL1-16							

Hydraulic Fluids

Hydraulic Fluids

Use petroleum base oils such as anti-wear type hydraulic oils equivalent to ISO VG-32 or 46. The recommended viscosity range is from 20 to 400 mm²/s and temperature range is from 0 to 60 °C, both of which have to be satisfied for the use of the above hydraulic oils.

Control of Contamination

Due caution must be paid to maintaining control over contamination of the operating oil which can otherwise lead to breakdowns and shorten the life of the unit.

Please maintain the degree of contamination within NAS Grade 10.

The suction port must be equipped with at least a 100 μm (150 mesh) reservoir type filter and the return line must have a line type filter of under 10 μm.

Instructions

Mounting

When installing the pump the filling port should be positioned upwards.

Alignment of Shaft

Employ a flexible coupling whenever possible, and avoid any stress from bending or thrust.

Maximum permissible misalignment is less than 0.1 mm TIR and maximum permissible misangular is less than 0.2°.

Suction Pressure

Permissible suction pressure at inlet port of the pump is between -16.7 and +50 kPa.

For piping to the suction port, use the pipes of the same diameter as that of the specified pipe flange to be used.

Make sure that the height of the pump suction port is within one meter from the oil level in the reservoir.

Hints on Piping

When using steel pipes for the suction or discharge ports, excessive load from the piping to the pump generates excessive noise.

Whenever there is fear of excessive load, please use rubber hoses.

Suction Piping

In case the pump is installed above the oil level, the suction piping and suction line filter should be located lower than the pump position to prevent air in the suction line.

Drain Piping

Install drain piping according to the chart and ensure that pressure within the pump housing should be maintained at a normal pressure of less than 0.1 MPa and surge pressure of less than 0.5 MPa.

Length of piping should be less than 1 m, and the pipe end should be submerged in oil.

In case ARL1 pump, a screw-in torque of fitting is 55 to 75 Nm. Do not apply bending and thrust torque to the fitting.

[Recommended Drain Piping Size]

Model	Fitting Size	Inside Dia. of Pipe
ARL1	3/8	10 mm

Bleeding Air

It may be necessary to bleed air from pump case and outlet line to remove causes of vibration. An air bleed valve (Model Number ST1004-*-10*, Page A-259) is recommended for this purpose.

■ Starting

Before first starting, fill pump case with clean operating oil via the filling port.

In order to avoid air blockage when first starting, adjust the control valves so that the discharged oil from the pump is returned direct to the reservoir or the actuator moves in a free load.

[Volume of Pre-fill Oil Required]

Model	Volume cm ³
ARL1	285

■ Setting Discharge Pressure and Delivery

At the time of shipment, the unit has been preset to maximum delivery and minimum discharge pressure.

Adjust the preset delivery and pressure to meet your system requirements.

● Adjustment of Discharge Pressure

Turning the adjustment screw clockwise, increases pressure.

[Volume adjusted by each full turn of the pressure adjustment screw]

Model Numbers	Adjustment Volume MPa
ARL1	1.5

■ Displacement Adjustment Function

This pump does not have a displacement adjustment function.

Install a flow control valve, if necessary.

ARL1 Series Piston Pumps

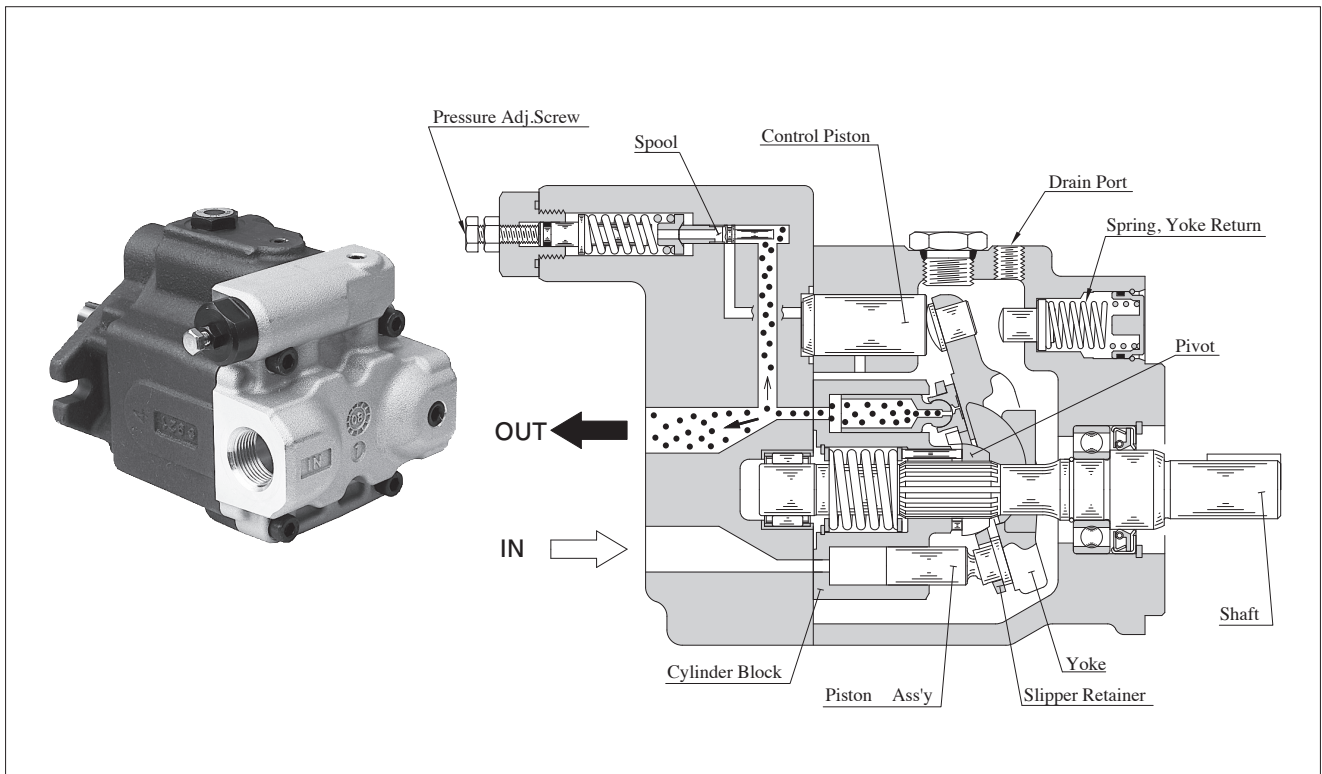

■ Features

- **Low noise and high reliability based on the long established experience**
 The noise at full cut-off with a pressure of 7 MPa, pump rotational speed of 1500 r/min, and measured distance of 1 m is as low as 55 dB(A) (representative value of ARL1-16). This series also has a high reliability based on Yuken's long-time experience of manufacturing piston pumps.
- **Lightweight and compact**
 Compared to the AR Series Variable Displacement Piston Pumps, this series is reduced by 40 % both in mass and volume, realizing a greatly lightweight and compact design.

ARL1 Series Piston Pumps, Pressure Compensator Type



Graphic Symbol

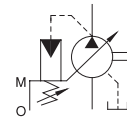

Specifications

Model Numbers	Geometric Displacement cm ³ /rev	Minimum Adj. Pressure MPa	Max. Operating Pressure MPa	Shaft Speed Range r/min		Approx. Mass kg
				Max.	Min.	
ARL1-6 *R01 *-10	6.2	1.2	7	1800	600	6.8 (Flange Mtg.) 9.0 (Foot Mtg.)
ARL1-8 *R01 *-10	8.5					
ARL1-12 *R01 *-10	12.3					
ARL1-16 *R01 *-10	16.3					

Model Number Designation

ARL1	-6	-F	R	01	S	-10
Series Number	Geometric Displacement	Mounting	Direction of Rotation	Control Type	Port Position	Design Number
ARL1	6 : 6.2 cm ³ /rev 8 : 8.5 cm ³ /rev 12 : 12.3 cm ³ /rev 16 : 16.3 cm ³ /rev	F : Flange Mtg. L : Foot Mtg.*	(Viewed from Shaft End) R : Clockwise	01 : Pressure Compensator Type	S : Side Port (Standard) A : Suction Port Position: Down Wards	10

★ Foot mounting is available only for side ported type.

Typical Performance Characteristics of **ARL1** at Viscosity 32 mm²/s [ISO VG 32 Oils, 40°C]

● **ARL1-6**

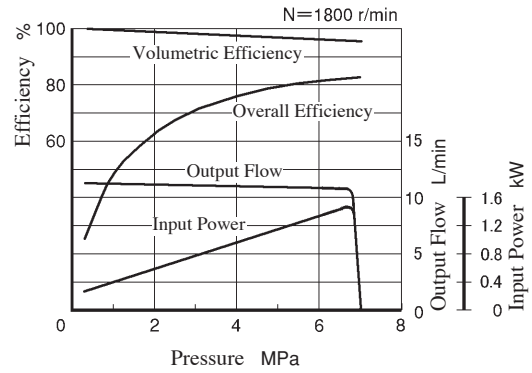
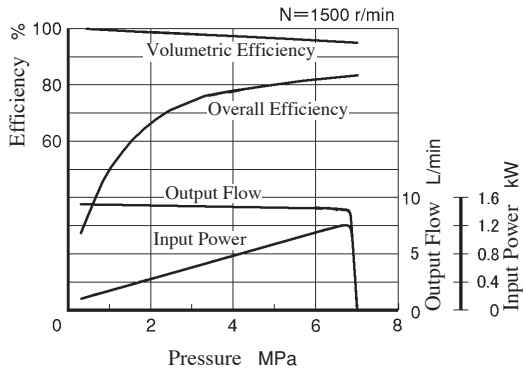

● **ARL1-8**

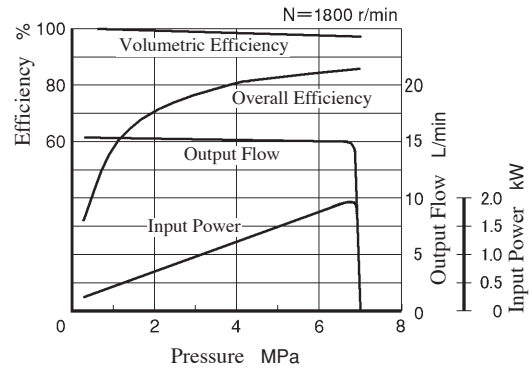
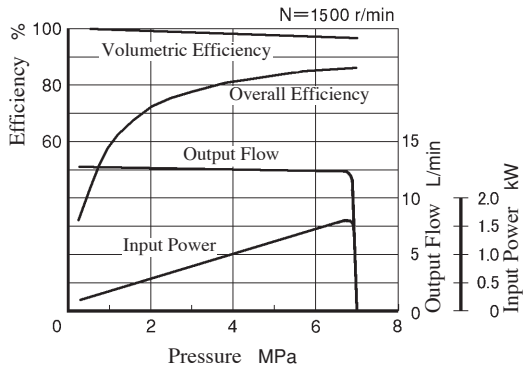

● **ARL1-12**

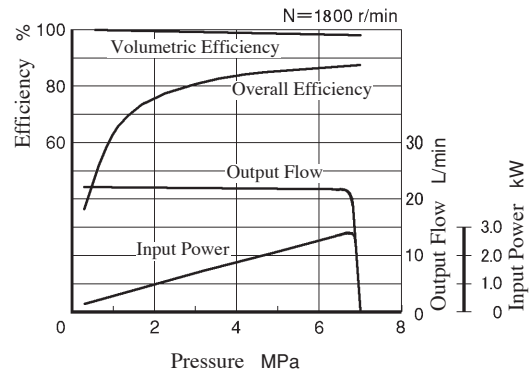
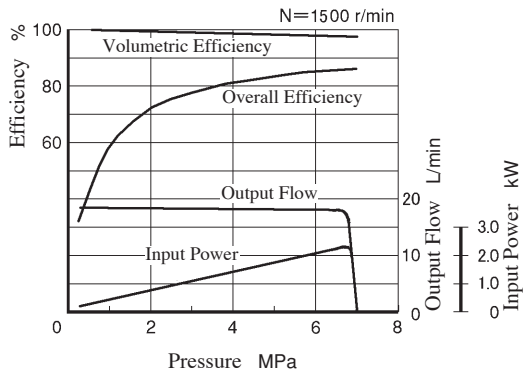

● **ARL1-16**

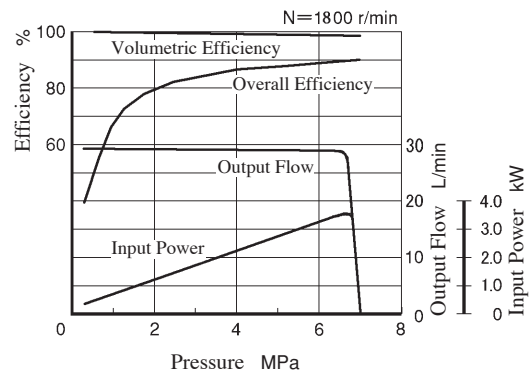
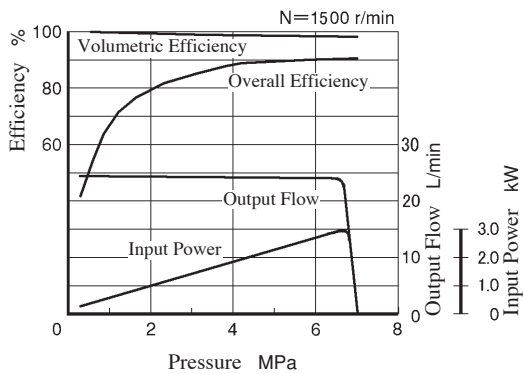

Typical Performance Characteristics of **ARL1** at Viscosity 32 mm²/s [ISO VG 32 Oils, 40°C]

Full Cut-off Power

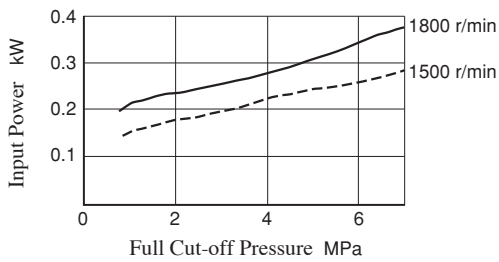

Drain

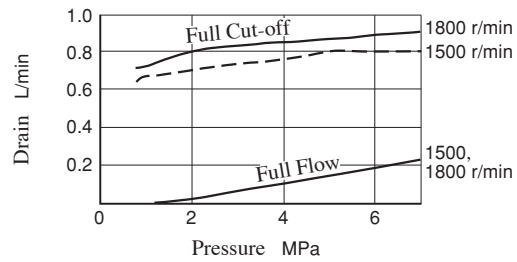

Noise Level [One meter horizontally away from pump head cover]

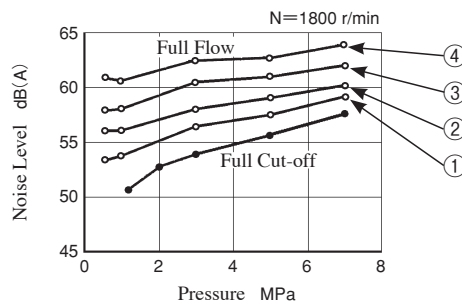
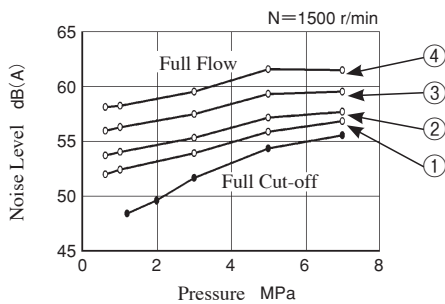

No.	Displacement
①	q = 6.2 cm ³ /rev
②	q = 8.5 cm ³ /rev
③	q = 12.3 cm ³ /rev
④	q = 16.3 cm ³ /rev

Response Characteristics Change in Accordance with Circuits and Operating Conditions

Test Circuit and Conditions

Circuit

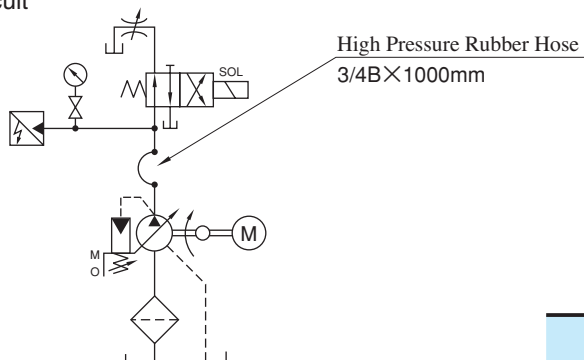

Conditions

- Shaft Speed : 1500 r/min
- Hydraulic Fluid : ISO VG32 Oil
- Oil Temperature : 40 °C (Viscosity 32 mm²/s)

Result of Measurement

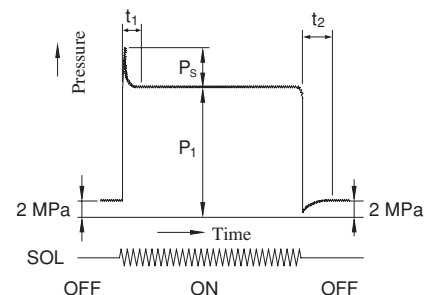

Model	Full Cut-off Pressure P ₁ MPa	Response Time ms		Overshoot Pressure P _s MPa
		t ₁	t ₂	
ARL1	7	180	125	2.5

Side Port Type

ARL1- *-FR01S

ARL1- *-LR01S

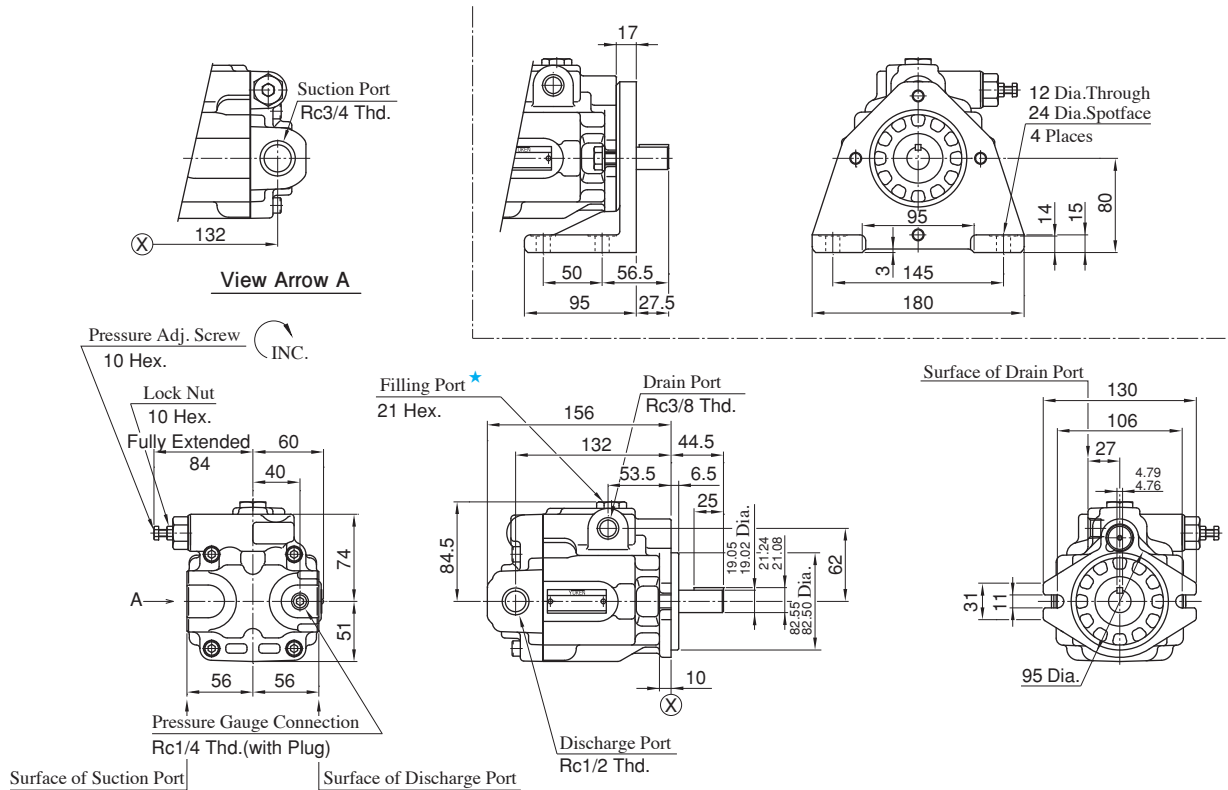

★ Install the pump so that the “Filling Port” is at the top.

Suction Port Position : Down Wards

ARL1- *-FR01A

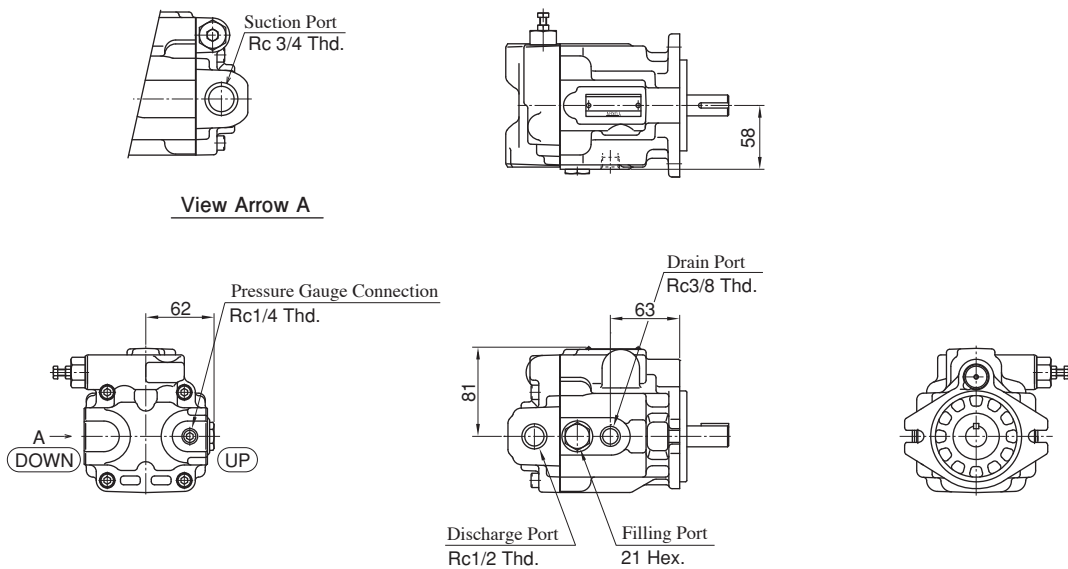

● For other dimensions, refer to “Side Port Type”.

Spare Parts List

ARL1-6/8/12/16- * R01

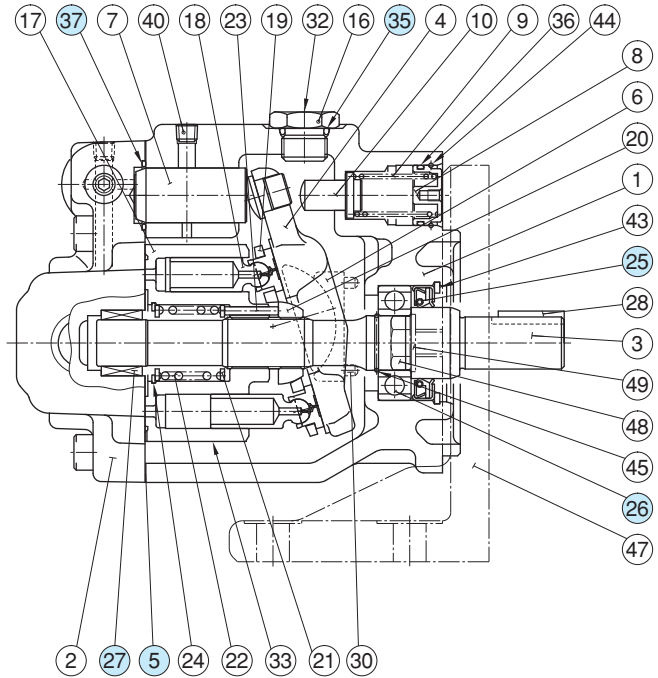
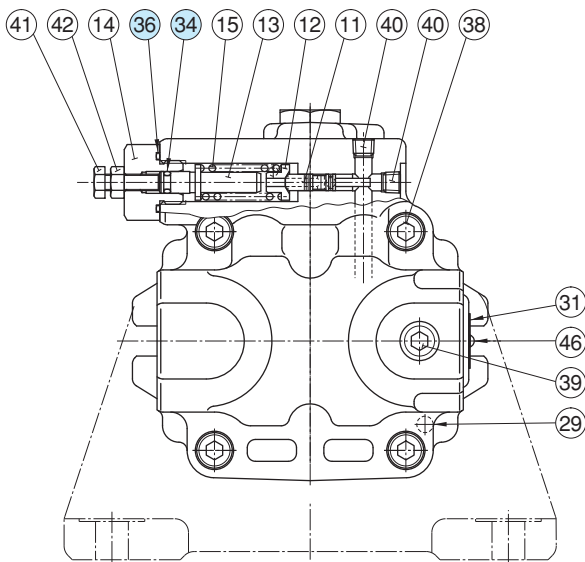

List of Seals and Bearings

Item	Name of Parts	Part Numbers	Qty.
5	Gasket	1202-PK314357-5	1
25	Oil Seal	TK280035-7	1
26	Bearing	1202-PK413170-2	1
27	Bearing	1202-PK413171-0	1
34	O-Ring	OR NBR-70-1 P5-N	1
35	O-Ring	OR NBR-90 P14-N	1
36	O-Ring	AS 568-018 (NBR-70-1)	2
37	O-Ring	AS 568-020 (NBR-90)	1