

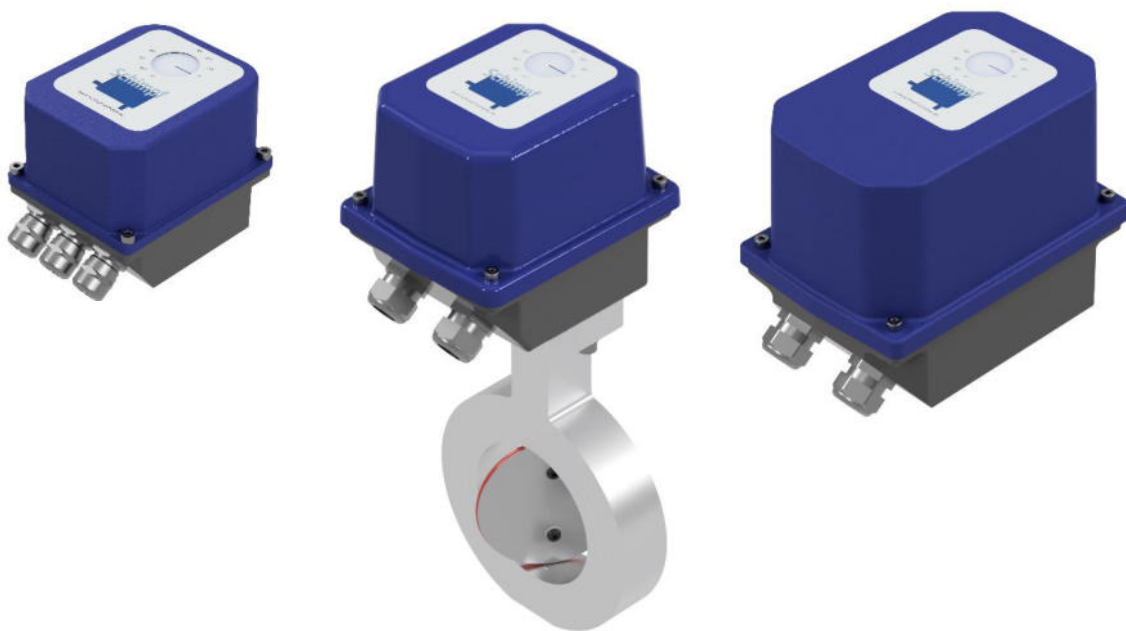

Operating Instructions

Actuating drive 00-10/30 STEP
Actuating drive 00-15/30 STEP
Actuating drive 01-15/30 STEP



Antriebs- & Regeltechnik

Schimpf GmbH

Bonholzstraße 17

71111 Waldenbuch, Germany

Tel: +49 (0)7157 52756-0

Fax: +49 (0)7157 52756-99

Email: Info@Schimpf-Antriebe.de

Web: www.Schimpf-Antriebe.de

Antriebs- & Regeltechnik Schimpf GmbH claims copyright protection for this documentation.

This documentation may not be modified, extended, reproduced or passed on to third parties without the prior consent of Antriebs- & Regeltechnik Schimpf GmbH. For further information, please contact Antriebs- & Regeltechnik Schimpf GmbH.

This documentation includes specifications for the relevant products but does not guarantee that they have any particular properties. We reserve the right to make technical changes!

Published in: 05/2024

Liability and guarantee

Antriebs- & Regeltechnik Schimpf GmbH accepts no liability or guarantee whatsoever in the event of the improper installation or use of the actuating drives. The technical specifications provided by us must be observed.

All actuating drives are tested for torque and functionality at the factory.

Contents

Safety instructions	6
Safety instructions for installation and maintenance	6
Safety instructions for commissioning	7
Device safety	9
Function and intended use	10
Overview and definitions.....	11
Commissioning.....	13
Installation.....	13
Opening the housing cover	14
Electrical connection	14
Setting the end positions.....	14
Configuring the analogue inputs and outputs.....	15
Calibration of the analogue inputs and outputs	15
Setting the direction of rotation	16
Setting the other operating parameters.....	16
Setting the cam switches	16
00-10 only: optional add-on board.....	16
00-15 only: optional add-on board.....	20
01-15 only: optional additional switches	23
Readiness for operation	23
Connections.....	25
Wiring diagram 00-10	26
Wiring diagram 00-15	27
Wiring diagram 01-15	29
Description of the connections 00-10, 00-15 and 01-15	30
Description of optional connections 00-10.....	33

Description of optional connections 00-15.....	34
Description of optional connections 01-15.....	35
Operation.....	36
Description of operating elements.....	37
Operation mode.....	39
Configuration mode 1	42
Mode 1: Setting the analogue signal.....	46
Mode 2: Setting the direction of rotation.....	46
Mode 3: Setting the torque.....	46
Mode 4: Setting the safe position in the event of a line break.....	46
Mode 5: Setting the running time	47
Mode 6: Setting the averaging	47
Mode 7: Setting the ramp.....	47
Mode 8: Setting the step size / hysteresis.....	48
Mode 9: Setting the end positions.....	48
Configuration mode 2	54
Mode 0: Return to standard mode	56
Mode 1: Test.....	56
Mode 2: Calibrate analogue output.....	57
Mode 3: Calibrate analogue input 4 mA or 2 V value.....	60
Mode 4: Calibrate analogue input 20 mA or 10 V value.....	61
Mode 5: Not used.....	62
Mode 6: Motion	62
Mode 7: Setting the heating	63
Mode 8: Restore factory settings	63
Mode 9: Not used.....	63
Error management.....	64
Error signalling	64

General information

Motor monitoring	64
Plausibility check.....	65
Troubleshooting	66
Technical specifications.....	68
Declaration of Conformity	70
Dimensional drawings.....	72
Notes	77

Safety instructions

Safety instructions for installation and maintenance

Specific safety requirements must be taken into account depending on when and under which ambient conditions you mount the actuating drive.



- **The installation, commissioning and maintenance of the drive may only be carried out by qualified specialists with sufficient mechanical and electrical expertise!**



- **Before installing or repairing an actuating drive, all cables connected to the drive must be disconnected from mains power!**



- **Before installing or repairing an actuating drive, all other affected devices/machines/systems must be switched off and, if necessary, disconnected from mains power!**



- **Before switching off devices/machines/systems, it is important to check that it is safe to do so. This is particularly important for process engineering systems!**



- **Make sure that no vibrations occur during installation!**
- Shutdowns may only be carried out after prior consultation with the plant manager, shift supervisor or safety engineer!
- Malfunctions must be reported immediately to the plant manager, shift supervisor or safety engineer in order to avoid danger!
- Secure your workplace and ensure that the devices/machines/systems you are working on cannot be put into operation unintentionally!
- When installing or repairing an actuating drive, the applicable safety and accident prevention regulations of the employers' liability insurance association must be observed!
- Before installing/repairing the actuating drive, make sure that the safety devices are functioning correctly!

- Before installing the actuating drive, check that the actuator can move freely!

Safety instructions for commissioning



- **Make sure that no danger to people, the environment or devices/machines/systems can result from the commissioning process or due to test settings!**



- **Make sure that the actuating drives can move freely and that there is no danger of personnel being crushed by the actuators/ fittings which will be driven. If necessary, erect barriers!**



- **When working on open and ready-to-operate actuating drives, there is a risk of touching live parts (24/115/230/400 V AC~)! Installation personnel must therefore be appropriately qualified and aware of this potential danger!**



- **When working on open and ready-to-operate actuating drives, no voltage may be applied to terminals 7 to 25!**



- **When working on open and ready-to-operate actuating drives, only the 3 operating buttons and the 2 rotary switches may be used. During all further work on an opened actuating drive, all cables connected to the drive must be disconnected from mains power!**



- **When mechanically adjusting the switches on the optional add-on board, all cables connected to the drive must be disconnected from mains power!**



- **Once the adjustments have been completed or paused, all cables connected to the actuator must be disconnected from mains power immediately!**



- **Once the adjustments have been completed or paused, the housing cover must be replaced immediately!**

- Secure the working area of the devices/machine/systems to prevent unintentional start-up or shut-down!

- After completing the adjustments, check whether the electrical signals of the actuating drives (especially the position feedback) correspond to the mechanical position of the drive! This applies in particular to the end positions!
- After completing the installation or configuration work, check that the actuating drive is functioning correctly. Check compliance with the end positions if necessary! Also check that any optional components are functioning properly!
- Finally, check that any safety devices are functioning properly to ensure that they are free of errors!

Device safety

- The actuating drives are high-quality products manufactured according to recognised technical rules, and they left the factory in a safe condition.
- In order to keep the actuating drives in a safe condition, it is imperative that installers/users strictly adhere to the manufacturer's instructions in this documentation and have the appropriate professional qualifications.
- The actuating drives may only be used for their intended purpose!
- The actuating drives may only be used when securely fixed on the relevant fitting!
- The actuating drives may only be operated in accordance with the values specified in the technical specifications!
- The actuating drives must not be installed, commissioned or adjusted on damaged supply lines or flanged system parts! The same requirements apply to damaged actuating drives!
- The device must not be disposed of with household waste. Please use the return and collection systems available to you to return the old device.

Function and intended use

The actuating drives are used in conjunction with an air or gas flow control valve or a comparable fitting to adjust volumes or throttle the flow rate.

The actuating drives are suitable for all applications requiring a rotary movement with high accuracy.

The actuating drives are factory-set for a rotary movement covering a range from 0° to 90°. The end positions can be freely adjusted.

The actuating drives are equipped with an externally readable position indicator as standard, a switchover between manual and automatic operation for servicing, two potential-free limit switches and two (01-15: three) freely adjustable potential-free additional switches.

The actuating drives are available for the following mains voltages:

AC: 90-260 V

DC: 24 V

As standard, the actuating drives feature three-point step control as well as an analogue control with position feedback (00-10: 0/4-20 mA) (00-15 and 01-15: 0/4-20 mA, 0/2-10 V).

The actuating drives have a wide range of configuration options such as direction of rotation, torque, running time, averaging, ramp or hysteresis.

Overview and definitions

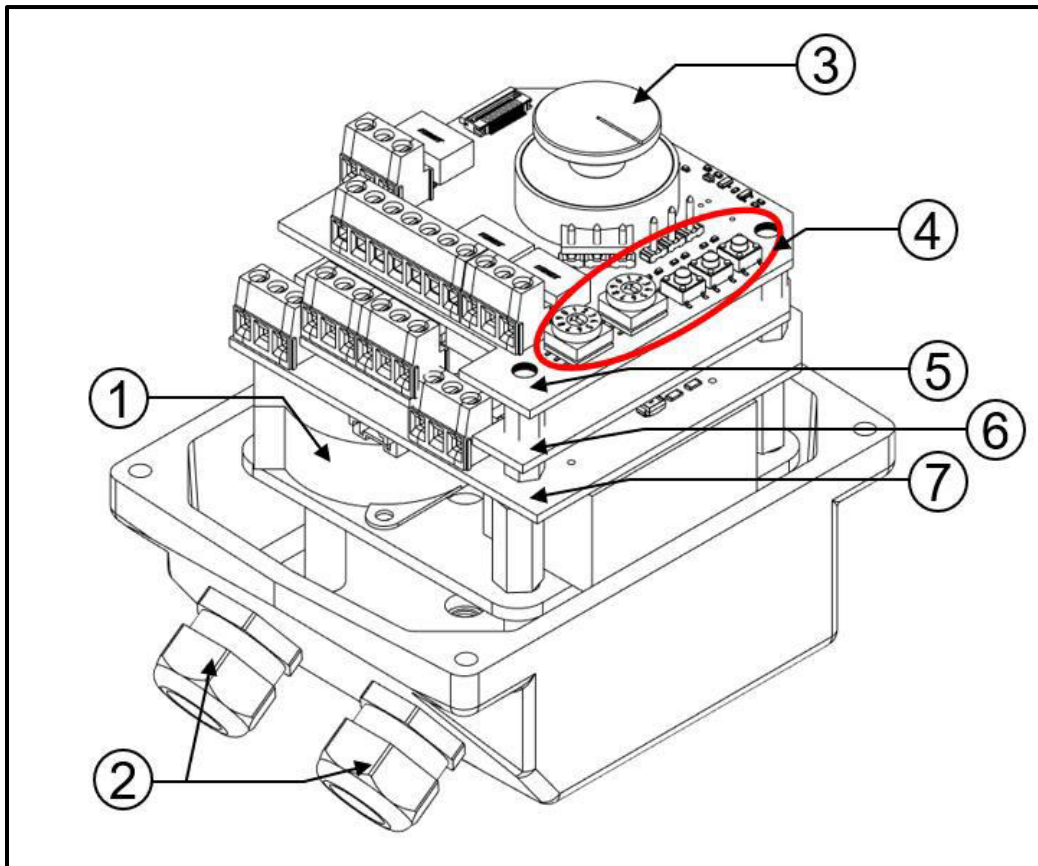
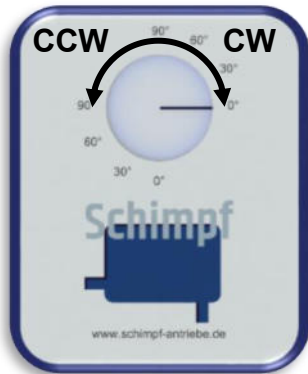

Figure 1: Device overview 00-15, also representative for 00-10 and 01-15

- | | |
|-----------------------------|-----------------------|
| 1 Motor | 5 CPU board |
| 2 Cable glands | 6 Add-on board |
| 3 Position indicator | 7 Base board |
| 4 Operating elements | |



Direction of rotation: All instructions related to the direction of rotation are from the perspective of a top-down view of the drive's position indicator.

A drive with the setting “**direction of rotation right**” closes the actuator clockwise from this perspective.

A drive with the setting “**direction of rotation left**” closes the actuator counterclockwise from this perspective.

Clockwise is abbreviated as **CW** below.

Counterclockwise is abbreviated as **CCW** below.

Relays or switch outputs each have a separate output for a contact that closes when triggered (normally open) and a contact that opens (normally closed). **Normally open** contacts are abbreviated as **NO** below.

Normally closed contacts are abbreviated as **NC** below.

Commissioning

Important: *The “Safety instructions for installation and maintenance” and the “Safety instructions for commissioning” provided in this document must be observed during the commissioning phase.*



Installation

The drive must be firmly screwed to the fitting to be moved using the available threaded holes on the flange plate. The drive shaft has a square socket as standard. The arrangement and size of the threaded holes as well as the square socket can be found in the **Dimensional drawings** and **Technical specifications** at the end of this document.

Adapters for other shaft designs are also available. An overview of the standard adapters can also be found in the **Dimensional drawings** at the end of this document.

Installing a Schimpf control valve

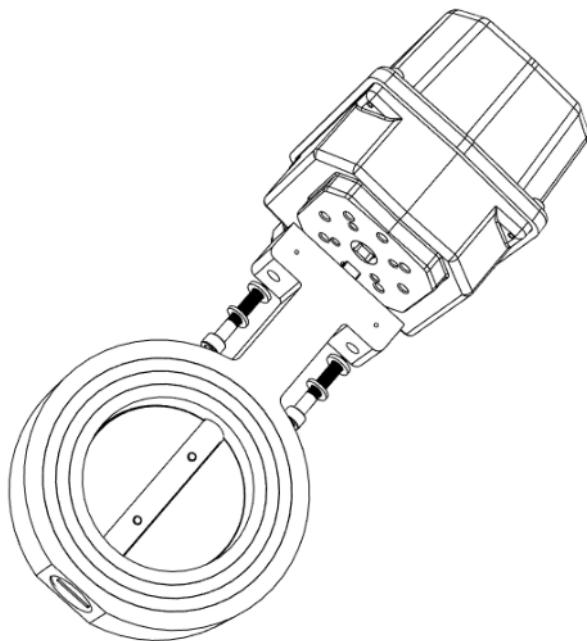

To mount a Schimpf drive on a Schimpf control valve, insert the square spindle at end of the valve shaft into the square socket of the drive. Make sure that the square socket of the drive and the square spindle of the valve are the same size. The valve is fixed in place using the two hexagon socket screws supplied with the valve. When installing, make sure that the drive is in the correct position relative to the valve (open or closed).

Specialised shafts and adapter sets for other valves are available on request.

Opening the housing cover

To open the housing cover, loosen the four 3 mm hexagon socket screws in the corners.

Important: *When working on the open device, always observe the safety requirements.*



Important: *Before opening the housing cover, disconnect all cables connected to the drive from mains power!*



Important: *As soon as the configuration of the device is complete or paused, the housing cover must be replaced immediately.*



Electrical connection

The connection cables must be fed through the cable glands (00-10: 3x M16x1.5, Ø: 5-9 mm), (00-15,01-15: 2x M20x1.5, Ø: 9-13 mm) into the housing.

The cable glands must then be tightened firmly. The permissible outside diameter of the inserted cables must be observed.

The connections must be made in accordance with the instructions in the section **Connections**.

Important: *The protective conductor (terminal 6) must always be connected.*



Setting the end positions

The end positions for “Closed” and “Open” are set at the factory to a setting range of approx. 90°. The position is determined using the potentiometer integrated into the device. The positions of the two end positions are stored in the device memory. If necessary, the end positions can be adjusted. The maximum setting angle is approx. 110°.

Instructions for setting the end positions are provided in the section **Configuration mode 1** under menu item **Mode 9: Setting the end positions** .

Configuring the analogue inputs and outputs

The analogue input (external setpoint input) as well as the analogue output (position feedback) are usually set to 4-20 mA as standard.

00-10 only:

The analogue input and the analogue output can be used either in 4-20 mA or 0-20 mA operation.

00-15 and 01-15 only:

The analogue input and the analogue output can be used in current or voltage mode (0/4-20 mA or 0/2-10 V). **Switch S15** on the base board must be set accordingly. This switch is used to switch the mode for position feedback between voltage and current.

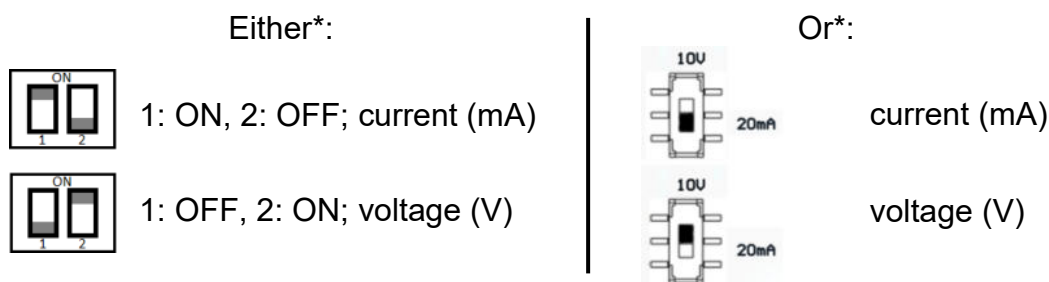

*depending on the device revision

The desired operating mode of the analogue interface must be stored in the device settings in line with the instructions under menu item **Mode 1: Setting the analogue signal** in the section **Configuration mode 1**. The operating mode is set jointly for input and output.

Calibration of the analogue inputs and outputs

The analogue input and the analogue output of the drive are calibrated at the factory. Recalibrating the analogue interface is usually only necessary if there are very high requirements for angular accuracy or, for example, if the connection cables are long. The calibration procedure is described in the section **Configuration mode 2** under the menu items **Mode 2, Mode 3, and Mode 4**.

When readjusting the end positions, the scalings of the analogue inputs and outputs automatically adapt to the newly set end positions. It is therefore not necessary to change the settings at the analogue interfaces.

Setting the direction of rotation

Change the direction of rotation as follows:

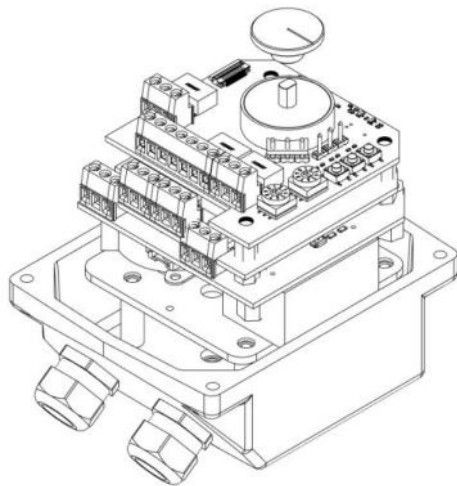

Figure 00-15 representative

Carefully pull the position indicator off the drive shaft and put it back on after rotating it by 180°.

The direction of rotation can be changed by following the instructions in the section **Configuration Mode** under menu item **Mode 2: Direction of Rotation**.

Setting the other operating parameters

If needed, the other operating parameters (torque, safe position, running time, averaging, ramp, hysteresis and heating) can be set by following the instructions in the section **Configuration mode 1**.

Setting the cam switches

The optional cam switches can be used for a number of purposes, such as controlling an external device or querying an intermediate position.

00-10 only: optional add-on board

Two additional potential-free, infinitely adjustable cam switches are available on the optional add-on board. Both cam switches are switched by the same camshaft, which has two adjustable cam discs N1 and N2. The switching positions are output via terminals 20 to 22 (see **Figure 8: Add-on board 00-10**)

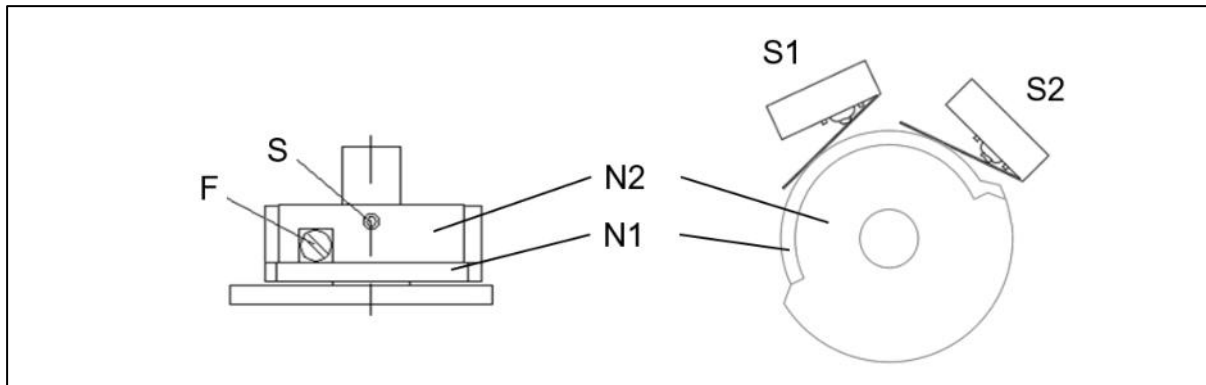

Figure 2: Overview of cam switch 00-10

The camshaft with cam discs **N1** and **N2** is fixed on the drive shaft with stud bolt **S**. Cam disc **N2** is always firmly connected to the camshaft. Cam disc **N1** can be moved relative to the camshaft using the adjusting screw **F**. The switch **S1** evaluates the position of cam disc **N1**, while switch **S2** evaluates the position of cam disc **N2**.

The settings of the cam discs for the two switches influence each other. As a result, the following procedure must be followed when setting the cam discs.

Restriction due to the narrow design: With a standard opening angle of 90° , both positions cannot be below 25° at the same time. Likewise, both positions must not be above 65° at the same time.

Important: **Switch off the power supply whenever you adjust the device with tools.**



The cam switches of model 00-10 are located on the underside of the add-on board. The following illustrations are still shown from a top-down perspective looking in the direction of the position indicator.



All cables connected to the drive must be disconnected from mains power!

Use the adjusting screw **F** to bring the lower, thin washer **N1** of the camshaft into congruence with the upper washer **N2**. If necessary, loosen the stud bolt **S** until the camshaft can be turned on the drive shaft.

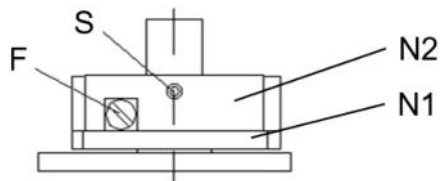

Connect the supply voltage!

Move the drive to the 0° position by electrical rotation.

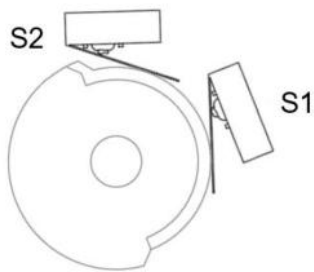

Move the actuator to the first position to be switched by electrical rotation. For clockwise-turning drives, first move the actuator to the larger of the two positions. For counterclockwise-turning drives, the actuator must be moved to the smaller of the two positions first.



Disconnect the supply voltage from the mains!

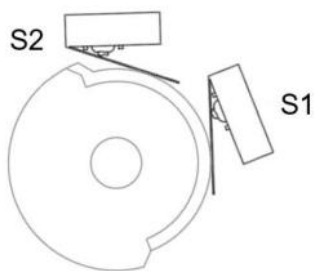

Turn the loose switching cam so that both switches **S1** and **S2** are not switched.



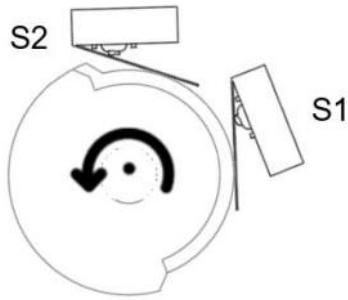

Now turn the loose switching cam counterclockwise (CCW) until switch **S1** audibly switches.

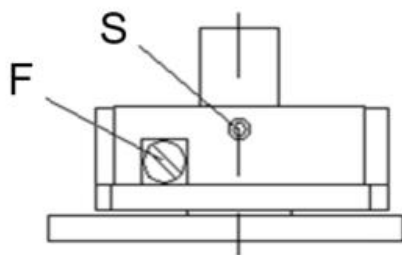

Tighten the stud bolt **S**.

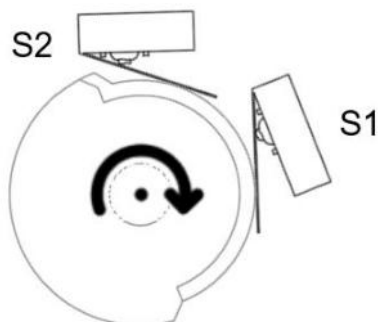

Connect the supply voltage!

Move to the second position to be switched by electrical rotation.



Disconnect the supply voltage from the mains!

Turn the thin cam disc **N1** using adjusting screw **F** until switch **S2** audibly switches.

Connect the supply voltage!

Check the set switching positions with electrical rotation.

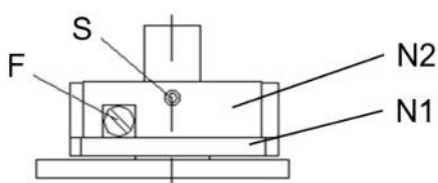

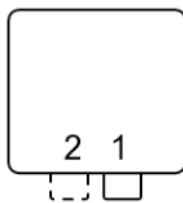

Switch S 16
 Pos 1: Switch S1 & S2 = NC
 Pos 2: Switch S1 & S2 = NO

Switch **S16** can be used to set whether the two cam switches **S1** and **S2** behave as normally closed (NC) or normally open (NO) contacts.

00-15 only: optional add-on board

Two additional potential-free, infinitely adjustable cam switches are available on the optional add-on board. Both cam switches are switched by the same camshaft, which has two adjustable cam discs N1 and N2. The switching positions are output via terminals 20 to 25 (see **Figure 11: Add-on board 00-15**).

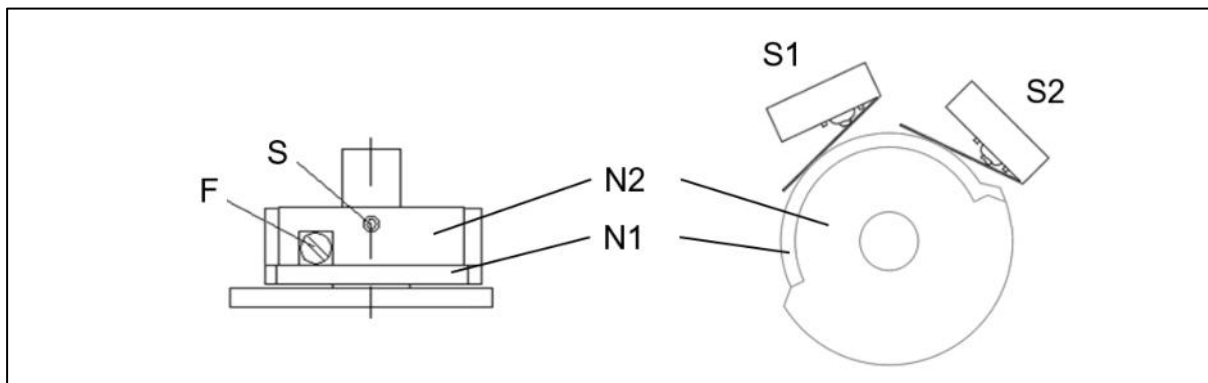

Figure 3: Overview of cam switch 00-15

The camshaft with cam discs **N1** and **N2** is fixed on the drive shaft with stud bolt **S**. Cam disc **N2** is always firmly connected to the camshaft. Cam disc **N1** can be moved relative to the camshaft using the adjusting screw **F**. The switch **S1** evaluates the position of cam disc **N1**, while switch **S2** evaluates the position of cam disc N2.

The settings of the cam discs for the two switches influence each other. As a result, the following procedure must be followed when setting the cam discs.

Restriction due to the narrow design: With a standard opening angle of 90°, both positions cannot be below 25° at the same time. Likewise, both positions must not be above 65° at the same time.

Important: **Switch off the power supply whenever you adjust the device with tools.**



All cables connected to the drive must be disconnected from mains power!

Use the adjusting screw **F** to bring the lower, thin washer **N1** of the camshaft into congruence with the upper washer **N2**. If necessary, loosen the stud bolt **S** until the camshaft can be turned on the drive shaft.

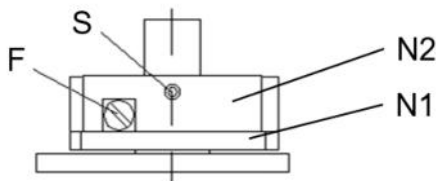

Connect the supply voltage!

Move the drive to the 0° position by electrical rotation.

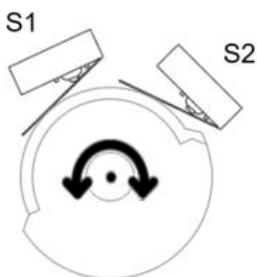

Move the actuator to the first position to be switched by electrical rotation. For clockwise-turning drives, first move the actuator to the larger of the two positions. For counterclockwise-turning drives, the actuator must be moved to the smaller of the two positions first.



Disconnect the supply voltage from the mains!

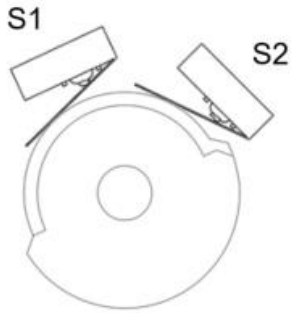

Turn the loose switching cam so that both switches **S1** and **S2** are not switched.

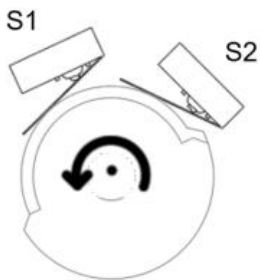

Now turn the loose switching cam counterclockwise (CCW) until switch **S2** audibly switches.

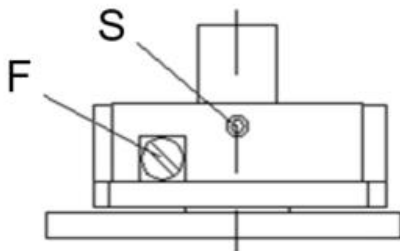

Tighten the stud bolt **S**.

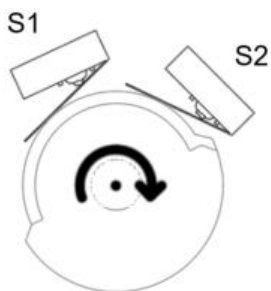

Connect the supply voltage!

Move to the second position to be switched by electrical rotation.





Disconnect the supply voltage from the mains!

Turn the thin cam disc **N1** using adjusting screw **F** until switch **S1** audibly switches.

Connect the supply voltage!

Check the set switching positions with electrical rotation.

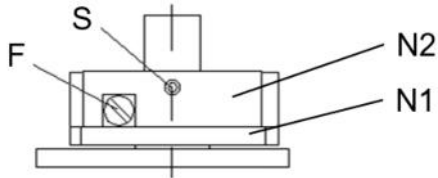

01-15 only: optional additional switches

Important: **Switch off the power supply whenever you adjust the device with tools.**



Move to the desired position. Secure the cams on the shaft with stud bolt **S**. Fine adjustments can be made with a screwdriver on adjusting screw **F**. To do this, turn the adjusting screw **F** until a slight click of the switch can be heard. The switching positions are output via terminals 20 to 28.

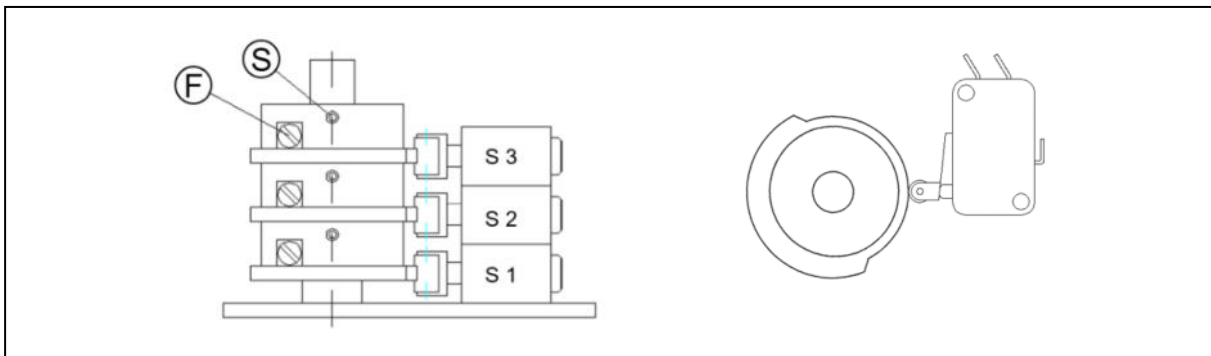
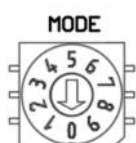

Figure 4: Optional additional switches 01-15

Readiness for operation

To make the device ready for operation, set the rotary switch **Mode** (see **Figure 1**) to position **“0”**.



Commissioning

The Parameter rotary switch must be set to the desired operating mode by following the instructions in the section **Operation** mode.

Mode	Parameter								
	0	1	2	3	4	5	6	7	8
0	Idle / disabled	Manual movement	Analogue control with enable	3-point step with enable	Analogue control, ignore enable	3-point step, ignore enable	Manual movement, ignore limit switch	2-point	2-point with Interim position

Close the housing cover and tighten the four 3 mm hexagon socket screws in the corners. Ensure that the seal is correctly seated.

Important: **Before closing the housing cover, disconnect all cables connected**



to the drive from mains power!

The installation must be put through a function test.

Connections

The national regulations for electrical installations must be observed when connecting the actuating drives. The actuating drives may only be connected by a qualified electrician. Follow the connection diagram in the cover and the technical guidance on the outside of the actuating drive.

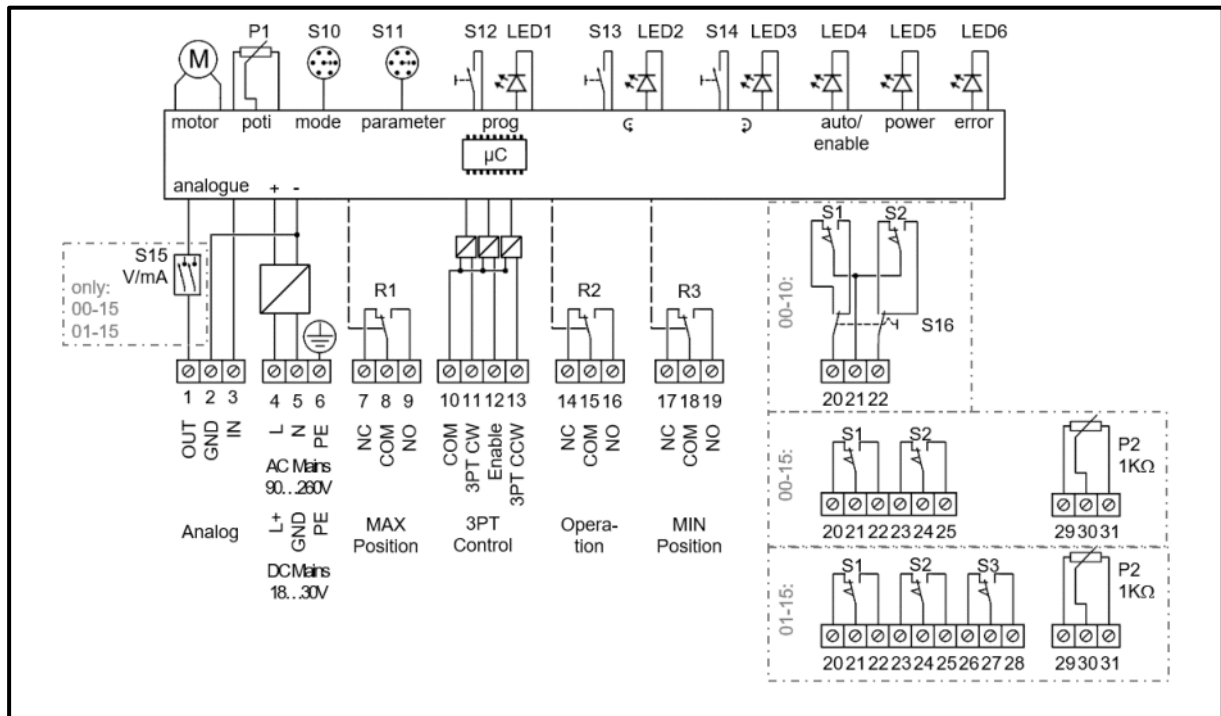

Figure 5: Circuit diagram, simplified

Wiring diagram 00-10

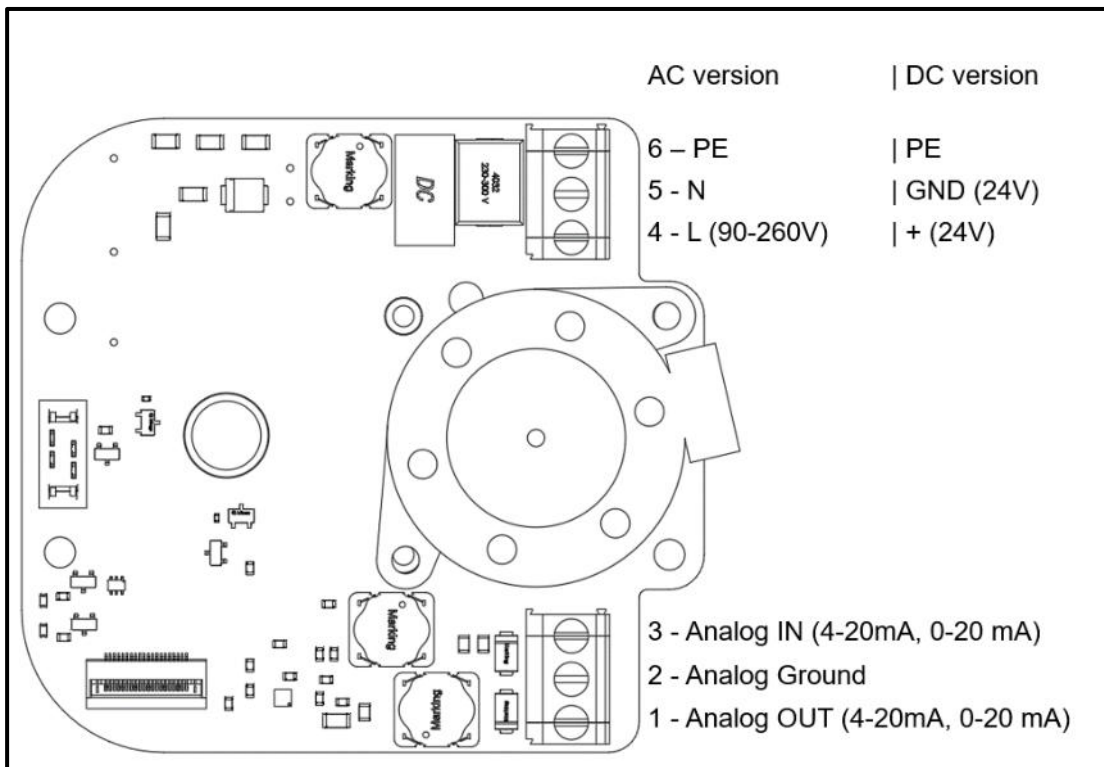

Figure 6: Base board 00-10

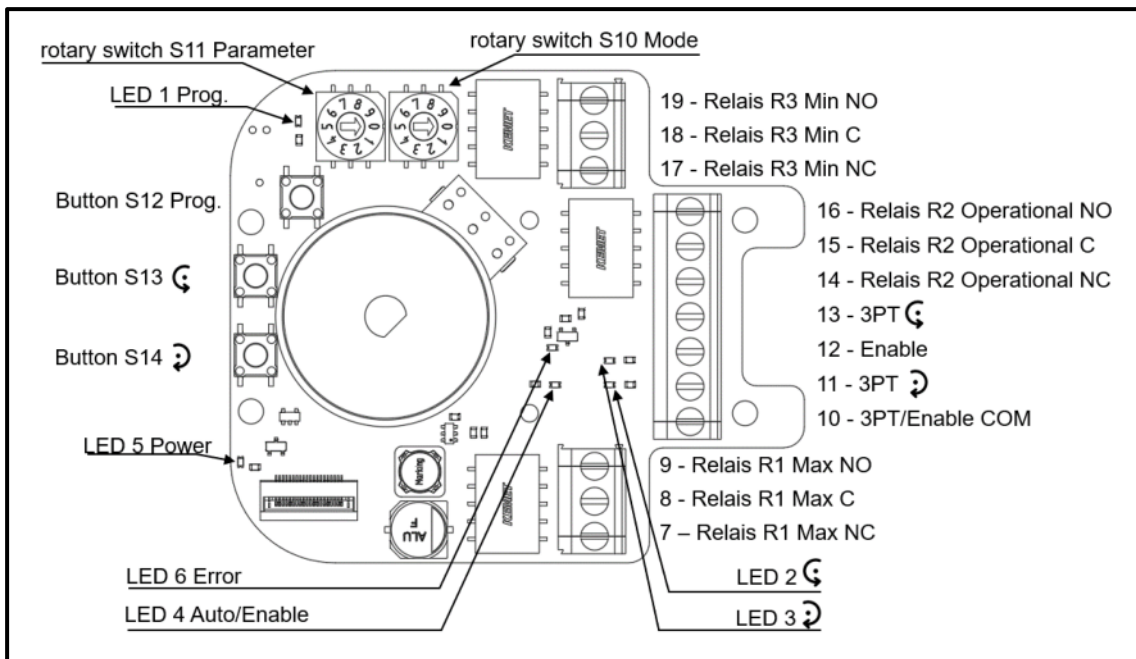

Figure 7: CPU board 00-10

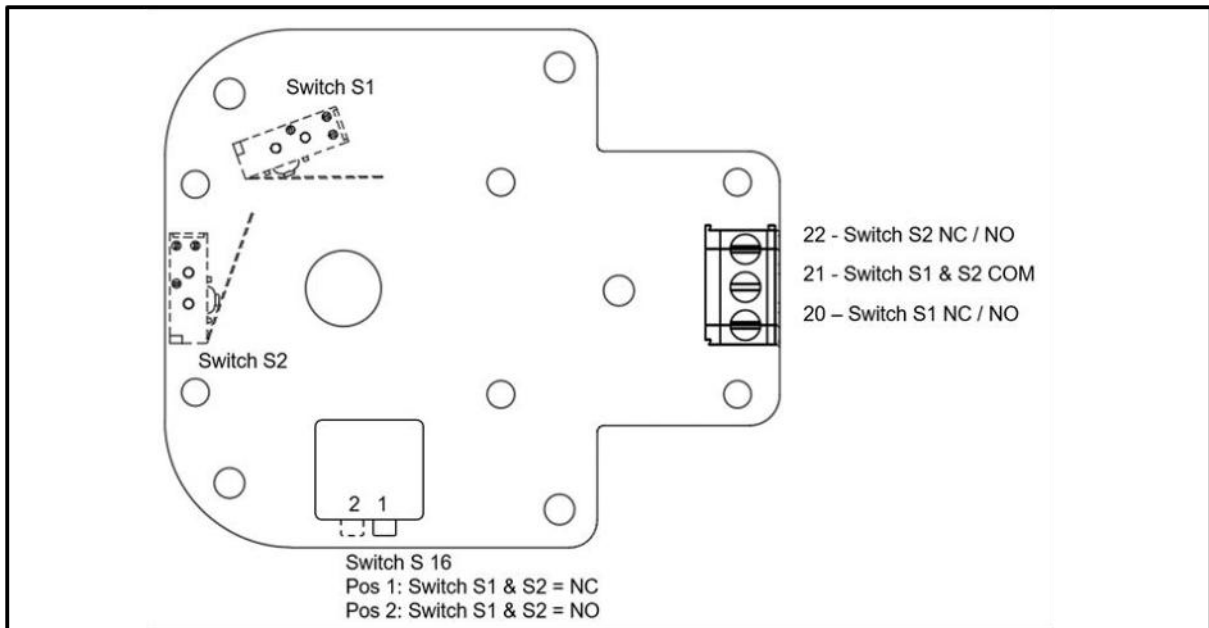

Figure 8: Add-on board 00-10

Wiring diagram 00-15

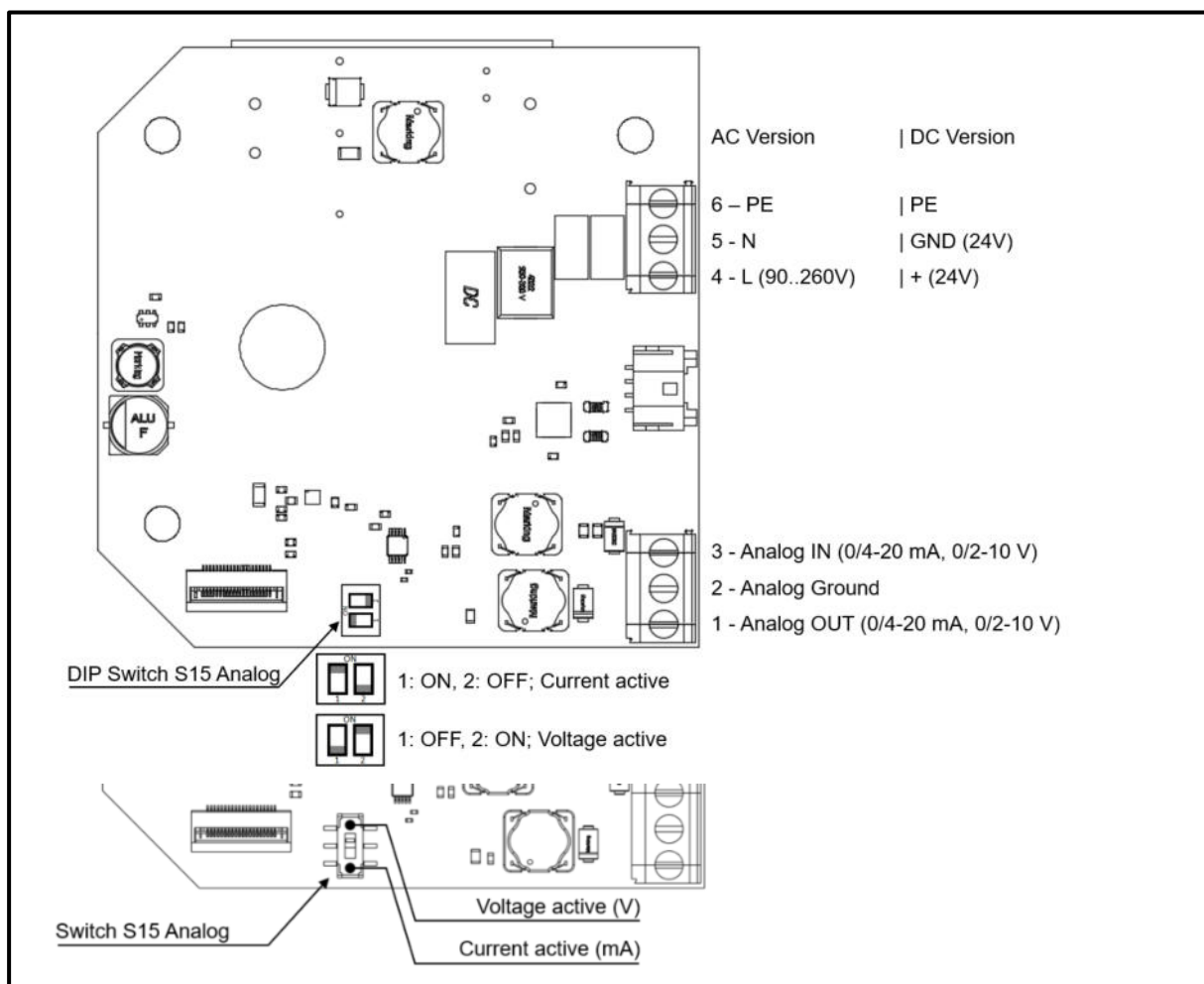

Figure 9: Base board 00-15 (Version S15 depending on the device revision)

Connections

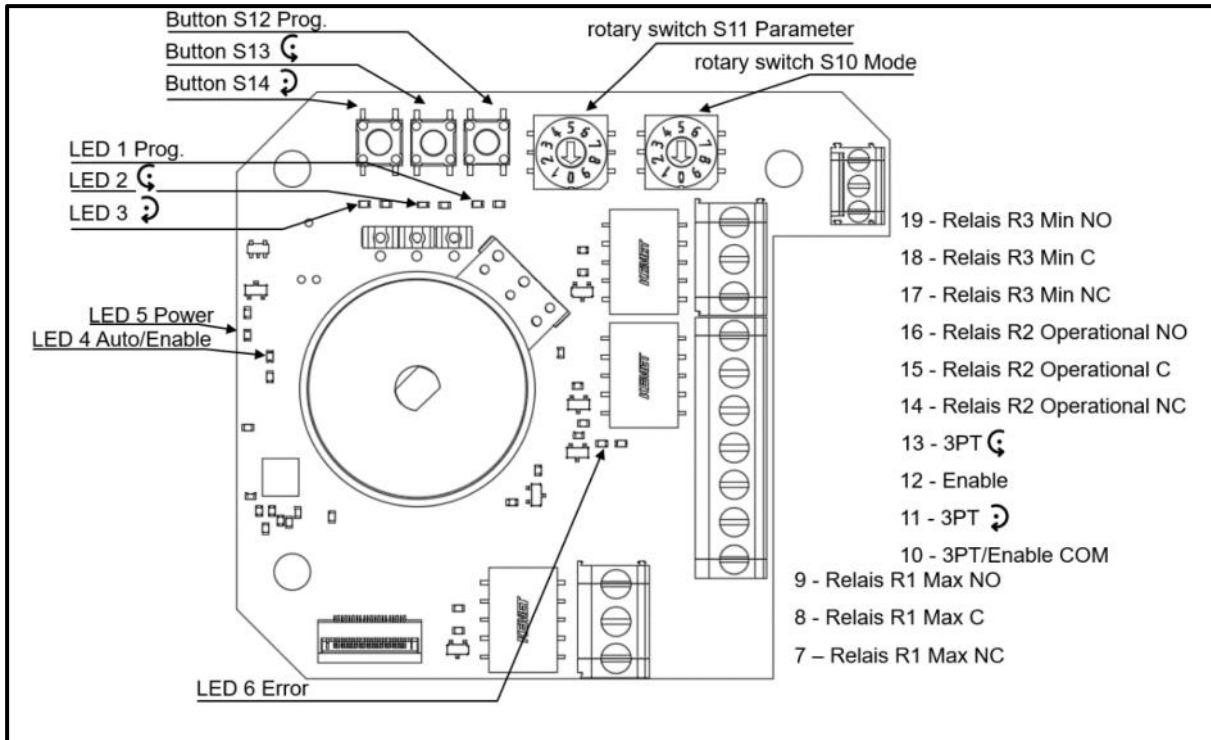

Figure 10: CPU board 00-15

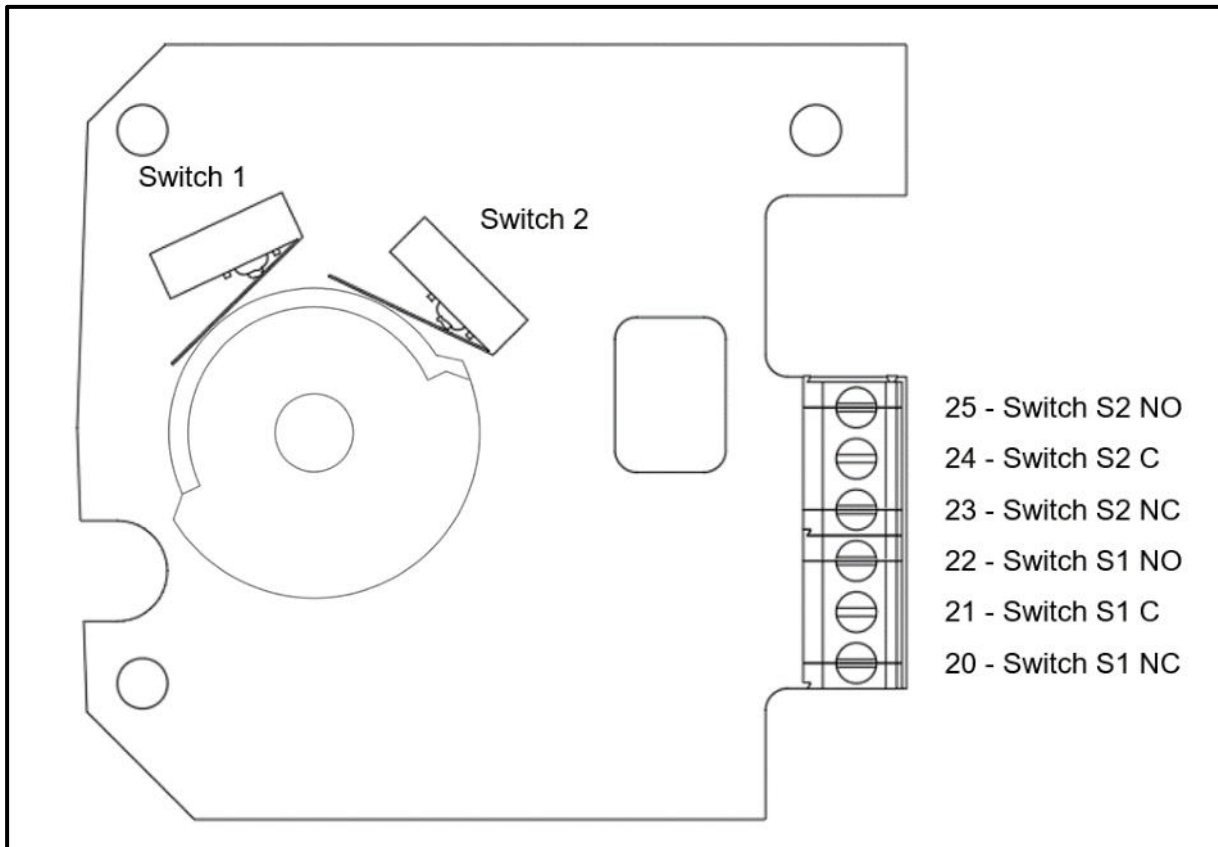

Figure 11: Add-on board 00-15

Wiring diagram 01-15

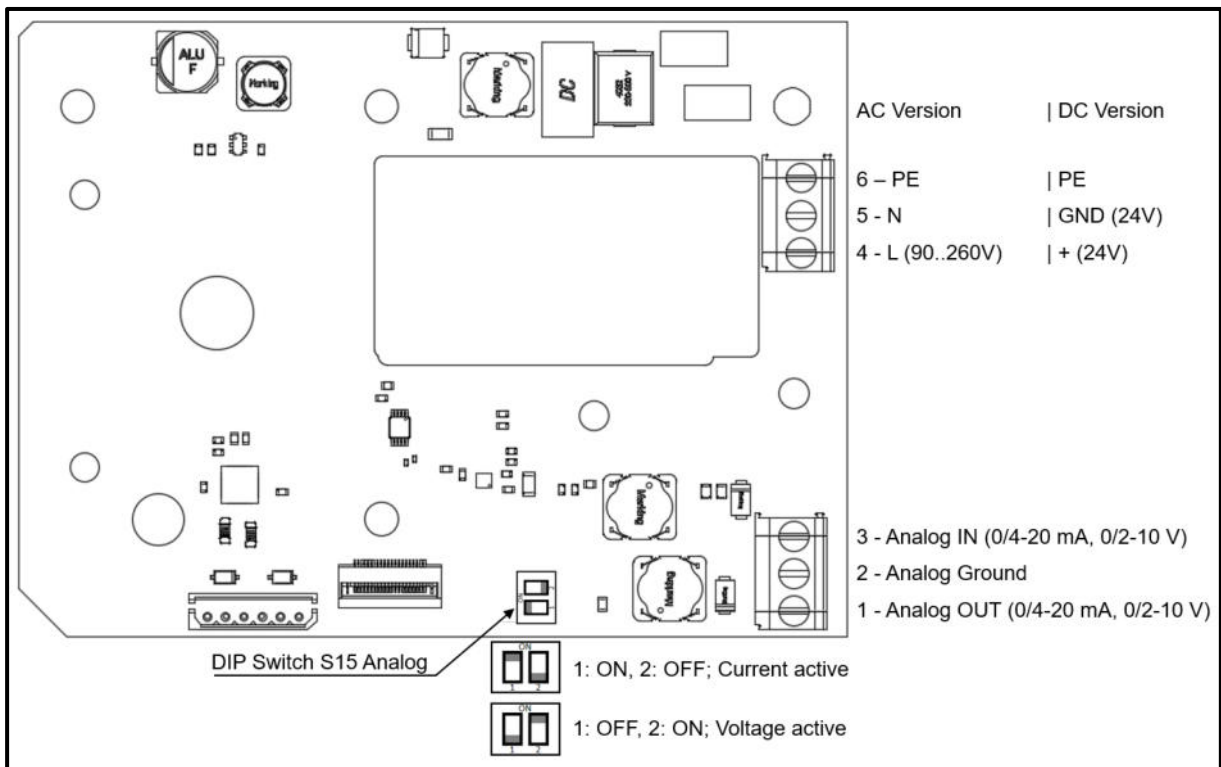

Figure 12: Base board 01-15

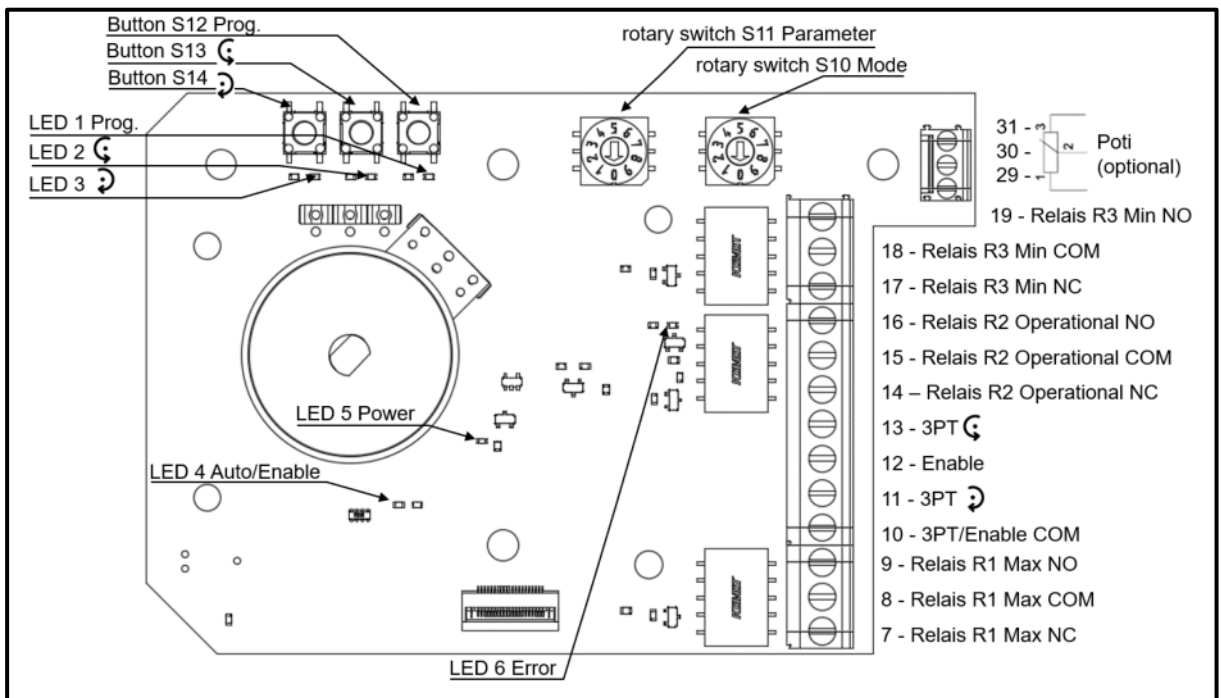

Figure 13: CPU board 01-15

Description of the connections 00-10, 00-15 and 01-15



Important:

Control and regulation lines must be shielded.

Terminal: The analogue signal (current/voltage) of the position feedback is output at terminal 1 of the base board. The reference of the analogue signal is connected to terminal 2.

1

Current source: max. 12V output voltage, max. load 500 Ω

Voltage source: max. 12V output voltage, max. 30 mA current

Terminal: The reference potential GND for input and output signal lines (terminals 1 and 3) is connected to this terminal.

2

The ground is not galvanically isolated from the DC supply voltage. There is a separation from PE.

Terminal: The external setpoint input (current/voltage) is connected to terminal 3 of the base board. The reference of the analogue signal is connected to terminal 2.

3

Max. input voltage: 12 V, current input: Load: 500 Ω

Terminal: **DC device version (18..30 V DC):**

4

The positive conductor of the DC supply voltage is connected to this terminal.

It is used to supply the drive with a continuous voltage.

AC device version (90..260 V AC):

The phase of the mains voltage is connected to this terminal.

It is used to supply the drive with a continuous voltage.

Terminal: **DC device version (18..30 V DC):**

5

The ground of the supply voltage is connected to this terminal.

AC device version (90..260 V AC):

The neutral conductor of the mains voltage is connected to this terminal.

Terminal: The protective conductor is connected to this terminal.

6

Important: *The protective conductor must always be connected for both the DC and AC versions.*



Important: *With the DC version of the device, AC voltage must never be applied to terminals 4 and 5 and vice versa! Danger of destruction!*



Terminals: Relay output R1 “Max position”

7,8,9 This relay switches when the drive has reached the maximum position.

Terminal 7: Normally closed (NC) contact

Terminal 8: Reference potential (COM)

Terminal 9: Normally open (NO) contact

AC switching capacity: Max. 250 V, 500 mA, resistive load

DC switching capacity: max. 220 V, 500 mA, resistive load

Terminal: The reference potential for the three-point step control and the enable signal (terminals 11, 12 and 13) is connected to this terminal (DC version: GND, AC version: N).

10

Important: *For the DC device version, a DC voltage (18-40 V DC) must be applied to terminals 11, 12 and 13!*



For the AC device version, an AC voltage (110..265 V AC) must be applied to terminals 11, 12 and 13!

AC version: 90..260 V AC, max. current 5 mA

DC version: 18..30 V, max. current 10 mA

Terminal: “Three-point step” operating mode:

11 If a voltage is applied to this terminal, the drive will rotate clockwise (CW)



. If the voltage is interrupted at terminal 11 or the end position is reached, the rotary movement stops.

“Two-point” operating mode:

If voltage is applied to this terminal, the actuator moves to the "OPEN" position. If the voltage is interrupted, the actuator moves to the "CLOSED" position (only two-point with intermediate position: If voltage is applied to terminal 13, the actuator moves to the programmed intermediate position).

(reference potential: terminal 10)

Terminal: Enable signal: If a voltage is applied to this terminal, the setpoint applied to terminal 3 (“control” operating mode) is enabled or terminals 11 and 13 (“three-point step” operating mode) are enabled, depending on the operating mode (reference potential: terminal 10).

Terminal: “Three-point step” operating mode:
13 If a voltage is applied to this terminal, the drive will rotate counterclockwise (CCW) . If the voltage is interrupted at terminal 13 or the end position is reached, the rotary movement stops.

“Two-point with intermediate position” operating mode:

If voltage is applied to this terminal and no voltage is applied to terminal 11, the drive moves to the programmed intermediate position. If no voltage is applied, the drive behaves according to the status at terminal 11.

(reference potential: terminal 10)

Terminals: Relay output R2 “Ready for operation”
14,15,16 This relay switches when the drive is ready for operation and drops out when the drive is not ready for operation or if there is an error.

Terminal 14: Normally closed (NC) contact

Terminal 15: Reference potential (COM)

Terminal 16: Normally open (NO) contact

AC switching capacity: Max. 250 V, 500 mA, resistive load

DC switching capacity: max. 220 V, 500 mA, resistive load

Terminals: Relay output R3 “Min position”
17,18,19 This relay switches when the drive has reached the minimum position.

Terminal 17: Normally closed (NC) contact

Terminal 18: Reference potential (COM)

Terminal 19: Normally open (NO) contact

AC switching capacity: Max. 250 V, 500 mA, resistive load

DC switching capacity: Max. 220 V, 500 mA, resistive load

Description of optional connections 00-10

Terminals: Potential-free output switches 1 & 2

20,21,22

Terminal 20:	Normally closed (NC) or normally open (NO) contact of switch 1
Terminal 21:	Reference potential (COM) of switches 1 & 2
Terminal 22:	Normally closed (NC) or normally open (NO) contact of switch 2

Function normally closed (NC) or normally open (NO) depends on position of selector switch S16 on the add-on board.

AC switching capacity:	Max. 250 V, 500 mA, resistive load Max. 250 V, 250 mA, inductive load
DC switching capacity:	30 V, 1000 mA, resistive load Max. 125 V, 100 mA, resistive load 30 V, 500 mA, resistive load Max. 125 V, 30 mA, resistive load

Description of optional connections 00-15

Terminals: Potential-free output of switch 1

20,21,22 Terminal 20: Normally closed (NC) contact of switch 1

Terminal 21: Reference potential (COM) of switch 1

Terminal 22: Normally open contact (NO) of switch 1

AC switching capacity: Max. 250 V, 500 mA, resistive load
Max. 250 V, 250 mA, inductive load

DC switching capacity: 30 V, 1000 mA, resistive load
Max. 125 V, 100 mA, resistive load
30 V, 500 mA, resistive load
Max. 125 V, 30 mA, resistive load

Terminals: Potential-free output of switch 2

23,24,25 Terminal 20: Normally closed (NC) contact of switch 2

Terminal 21: Reference potential (COM) of switch 2

Terminal 22: Normally open contact (NO) of switch 2

AC switching capacity: Max. 250 V, 500 mA, resistive load
Max. 250 V, 250 mA, inductive load

DC switching capacity: 30 V, 1000 mA, resistive load
Max. 125 V, 100 mA, resistive load
30 V, 500 mA, resistive load
Max. 125 V, 30 mA, resistive load

Terminals: Potentiometer P2 1 K Ω / approx. 110°, without end stop

29,30,31

Terminal 29:

Terminal 30:

Terminal 31:

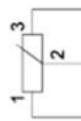

Description of optional connections 01-15

Terminals: Potential-free output of switch 1

20,21,22

Terminal 20: Normally closed (NC) contact of switch 1
Terminal 21: Reference potential (COM) of switch 1
Terminal 22: Normally open contact (NO) of switch 1
AC switching capacity: Max. 250 V, 500 mA, resistive load
Max. 250 V, 250 mA, inductive load
DC switching capacity: 30 V, 1000 mA, resistive load
Max. 125 V, 100 mA, resistive load
30 V, 500 mA, resistive load
Max. 125 V, 30 mA, resistive load

Terminals: Potential-free output of switch 2

23,24,25

Terminal 20: Normally closed (NC) contact of switch 2
Terminal 21: Reference potential (COM) of switch 2
Terminal 22: Normally open contact (NO) of switch 2
AC switching capacity: Max. 250 V, 500 mA, resistive load
Max. 250 V, 250 mA, inductive load
DC switching capacity: 30 V, 1000 mA, resistive load
Max. 125 V, 100 mA, resistive load
30 V, 500 mA, resistive load
Max. 125 V, 30 mA, resistive load

Terminals: Potential-free output of switch 3

26,27,28

Terminal 20: Normally closed (NC) contact of switch 3
Terminal 21: Reference potential (COM) of switch 3
Terminal 22: Normally open contact (NO) of switch 3
AC switching capacity: Max. 250 V, 500 mA, resistive load
Max. 250 V, 250 mA, inductive load
DC switching capacity: 30 V, 1000 mA, resistive load
Max. 125 V, 100 mA, resistive load
30 V, 500 mA, resistive load
Max. 125 V, 30 mA, resistive load

Terminals: Potentiometer P2 1 K Ω / approx. 110°, without end stop

29,30,31

Terminal 29:
Terminal 30:
Terminal 31:

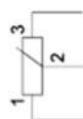

Operation

Important: When working on open and ready-to-operate actuating drives, there is a risk of touching live parts (24/115/230/400 V AC~)! Installation personnel must therefore be appropriately qualified and aware of this potential danger!



Important: When working on open and ready-to-operate actuating drives, no voltage may be applied to terminals 7 to 25!





Important: As soon as the configuration of the device is complete or paused, the housing cover must be replaced immediately.



Important: When working on open and ready-to-operate actuating drives, only the 3 operating buttons and the 2 rotary switches may be used. During all further work on an opened actuating drive, all cables connected to the drive must be disconnected from mains power!



The device is mainly operated using the three buttons **S12** “PROG”, **S13**  and **S14**  as well as the two rotary selector switches **S10** “Mode” and **S11** “Parameter” (see also: Figure 1: Device overview 00-15):

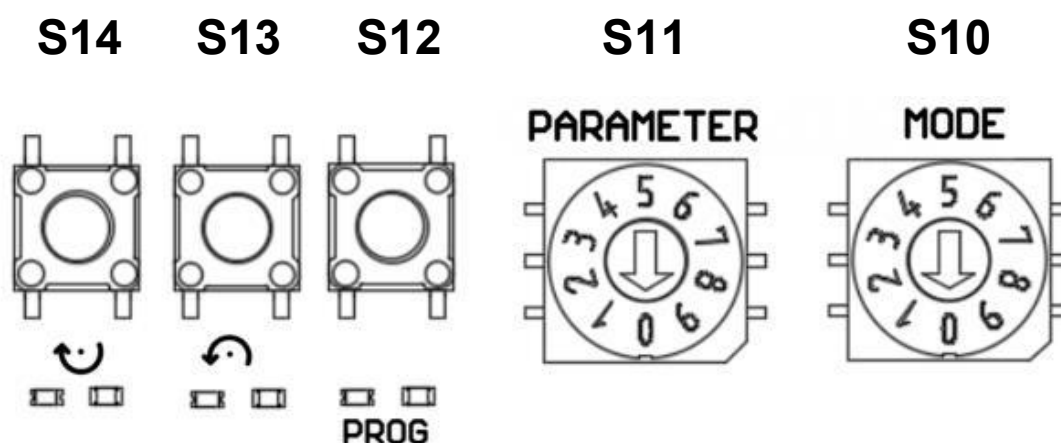

The rotary selector switches can be operated with a slotted screwdriver (e.g. 2.4 x 50). Device states are indicated using a number of LEDs.

When operating the actuating drive, a distinction is made between two different operating states: **Standard mode** and **Configuration mode**.

In **Standard mode**, the drive is controlled depending on the settings activated based on the input signals applied.

In **Configuration mode**, changes are applied to settings, such as changing the running time or the calibration for the analogue signals.

Description of operating elements

Rotary switch S10 When set to mode “0”, the drive is in normal operation.

In this mode, the desired operating mode can be selected using the “Mode” Parameter rotary switch. As soon as a mode other than “0” is selected, the drive will be in configuration mode.

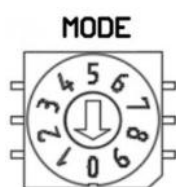

Rotary switch S11 In standard mode, the desired operating mode is selected using the Parameter rotary switch.

In configuration mode, the desired value is selected using the Parameter rotary switch.

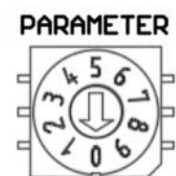

Button S12 In configuration mode, settings are confirmed by pressing and holding this button.

Button S13 In the “manual movement” and “manual movement, ignore limit switch”



operating modes, a counterclockwise (CCW) rotation of the drive is started . If the button is released or the end position is reached (operating mode “manual movement” only), the rotary movement stops. In configuration mode, the button may perform special functions.

Button S14 In the “manual movement” and “manual movement, ignore limit switch”





operating modes, a clockwise (CW) rotation of the drive is started . If



the button is released or the end position is reached (operating mode “manual movement” only), the rotary movement stops.

In configuration mode, the button may perform special functions.

LED 1
“PROG”
Red
 This LED will remain on as long as the drive is in configuration mode. This LED will flash to confirm that a setting has been changed using the “PROG” button in configuration mode.

LED 2 
Green
 In standard mode, this LED signals a counterclockwise (CCW) rotation of the drive .

In configuration mode, the LED may perform special functions.

LED 3 
Green
 In standard mode, this LED signals a clockwise (CW) rotation of the drive .

In configuration mode, the LED may perform special functions.

LED 4
“Enable”
Green
 This LED will remain on as soon a voltage is applied to terminal 12 (enable signal) and an operating mode is set which takes the enable signal into account.

LED 5
“Power”
Green
 This LED will remain on as soon as operating voltage is applied to the drive.

LED 6
“Error”
Red
 If this LED remains on, the drive is not ready for operation or there is an error.

Switch S15 00-15 and 01-15 only: This switch changes the mode for ext. setpoint input and position feedback between voltage and current.

”

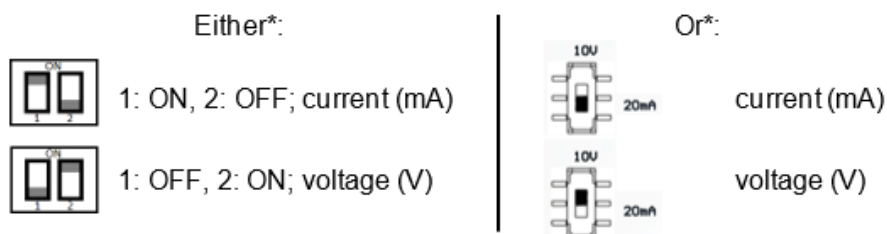

*depending on the device revision



Important:
The appropriate setting must also be made in mode 1: “Setting analogue signal”.



Operation mode

To put the actuator in standard mode, set the “**Mode**” rotary switch to “**0**”. In this mode, you can then use the “**Parameter**” rotary switch to select the operating mode.

Parameter 0: Operating mode idle or deactivated

The drive is in idle mode. The drive will not move regardless of the applied input signals. The “Ready for operation” relay is not switched.

Parameter 1: Manual movement mode

The drive can only be moved using the  and  buttons. When the minimum or maximum end position is reached, the rotary movement stops.

The “Ready for operation” relay is **not** switched.

Parameter 2: Control with setpoint enabling

When **voltage** is applied to terminal 12 (enable signal), the drive is in **control mode**. The drive will move to the position according to the analogue input signal at terminal 3.

If **no voltage** is applied to terminal 12 (enable signal), the drive is in **three-point step mode**: If a voltage is applied to terminal 11, this causes the drive to rotate clockwise

(CW) . If the voltage is interrupted at terminal 11 or the end position is reached, the rotary movement stops. If a voltage is applied to terminal 13, this causes the drive to

rotate counterclockwise (CCW) . If the voltage is interrupted at terminal 13 or the end position is reached, the rotary movement stops.

The “Ready for operation” relay is switched.

Parameter 3: Three-point step with enabling

If **voltage** is applied to terminal 12 (enable signal), the drive is in **three-point step mode**: If a voltage is applied to terminal 11, this causes the drive to rotate clockwise

(CW) . If the voltage is interrupted at terminal 11 or the end position is reached, the rotary movement stops. If a voltage is applied to terminal 13, this causes the drive to

rotate counterclockwise (CCW) . If the voltage is interrupted at terminal 13 or the end position is reached, the rotary movement stops.

If **no voltage** is applied to terminal 12 (enable signal), the drive is in **idle mode**. The drive will not move regardless of the other applied input signals.



The “Ready for operation” relay is switched.

Parameter 4: Control mode

The drive is in **control mode**. The drive will move to the position according to the analogue input signal at terminal 3.



The “Ready for operation” relay is switched.

Parameter 5: Three-point step mode

The drive is in three-point step mode: If a voltage is applied to terminal 11, this causes the drive to rotate clockwise (CW) . If the voltage is interrupted at terminal 11 or the end position is reached, the rotary movement stops. If a voltage is applied to terminal 13, this causes the drive to rotate counterclockwise (CCW) . If the voltage is interrupted at terminal 13 or the end position is reached, the rotary movement stops.

The “Ready for operation” relay is switched.

Parameter 6: Movement movement, ignore limit switch mode

The drive can only be moved freely using the  and  buttons. The rotary movement does not take into account the position of the limit switches. Take care that leaving the set movement range will not cause a dangerous situation (e.g. by moving the actuator against a mechanical stop).

The “Ready for operation” relay is **not** switched.

Parameter 7: Two-point mode

The drive is in the two-point operating mode: If **voltage is applied to terminal 11**, the drive moves to the "OPEN" position. If there is **no voltage at terminal 11**, the actuator moves to the "CLOSED" position.

The "Ready for operation" relay is switched.

Parameter 8: Two-point mode with intermediate position

The actuator is in two-point operation mode with intermediate position: If there is **voltage at terminal 11**, the actuator always moves to the "OPEN" position. If there is **no voltage at terminal 11 and no voltage at terminal 13**, the actuator moves to the "CLOSED" position. If there is **voltage at terminal 13 and no voltage at terminal 11**, the drive moves to the programmed intermediate position. The intermediate position is programmed via mode 9: parameter 3.

The "Ready for operation" relay is switched.

Parameter 9:

Parameter 9 is not assigned. The drive is in idle mode. The drive will not move regardless of the applied input signals. The "Ready for operation" relay is **not** switched.

Configuration mode 1

You can set the actuator to **configuration mode 1** by setting the **Mode** rotary switch to anything **other than “0”**. The “PROG” LED will stay on. The “Ready for operation” relay is not switched. You can then use the “**Parameter**” rotary switch to select different settings. Press and hold the “**Prog**” button to save your settings. The “**Prog**” **LED** will flash briefly to show that your settings have been saved. Any changes you make will only be permanently saved to the device when you set the “**Mode**” rotary switch back to “**0**”. The “**Prog**” **LED** will flash briefly to show that your changes have been saved. The actuator will then return to standard mode (exception: calibration values for the limit switches are saved immediately). Settings such as torque, running time, averaging, hysteresis and ramp influence each other to some extent. These parameters must be set appropriately to suit the requirements of the application. If inadmissible values are selected for the setting, these values will not be applied. An overview of the different options available for the parameters is provided in the table below (Default parameters are highlighted in grey, unless otherwise agreed):

Operation

Mode	Parameter									
	0	1	2	3	4	5	6	7	8	9
0	Idle / disabled	Manual movement	Analogue control with enable ⁴	3-point step with enable ⁵	Analogue control, ignore enable	3-point step, ignore enable	Manual movement, ignore limit switch	2-point	2-point with Interim position	
1	Analogue 4-20 mA		Analogue 0-20 mA							
2	Direction of rotation left	Direction of rotation right								
3 ¹	Torque 1 Nm	Torque 1.3 Nm	Torque 1.6 Nm	Torque 2 Nm	Torque 2.3 Nm	Torque 2.6 Nm	Torque 3.0 Nm	Torque 3.3 Nm	Torque 3.6 Nm	Torque 4 Nm
4 ²	Position 0% without triggering error relay	Stop at current position	Safe position 0%	Safe position 10%	Safe position 20%	Safe position 30%	Safe position 50%	Safe position 70%	Safe position 90%	Safe position 100%
5	Running time 60 s / 90°	Running time 55 s / 90°	running time 50 s / 90°	Running time 45 s / 90°	Running time 40 s / 90°	Running time 35 s / 90°	Running time 30 s / 90°	Running time 25 s / 90°	Running time 20 s / 90°	Running time 15 s / 90°
6	Average 0 sec	Average 0.1 sec	Average 0.2 sec	Average 0.4 sec	Average 0.6 sec	Average 0.8 sec	Average 1.0 sec	Average 1.2 sec	Average 1.5 sec	Average 1.8 sec
7 ³	Start/stop ramp 0.05 sec	Start/stop ramp 0.2 sec	Start/stop ramp 0.4 sec	Start/stop ramp 0.6 sec	Start/stop ramp 0.8 sec	Start/stop ramp 1.0 sec	Start/stop ramp 1.2 sec	Start/stop ramp 1.5 sec	Start/stop ramp 2.0 sec	Start/stop ramp 2.5 sec
8	Hysteresis 0.05% / 90°	Hysteresis 0.08% / 90°	Hysteresis 0.1% / 90°	Hysteresis 0.2% / 90°	Hysteresis 0.4% / 90°	Hysteresis 0.6% / 90°	Hysteresis 0.8% / 90°	Hysteresis 1.0% / 90°	Hysteresis 1.5% / 90°	Hysteresis 2.0% / 90°
9	Configuring both end positions (potentiometer)	Configure end position "CCW" (potentiometer)	Configure end position "CW" (potentiometer)	Configure Interim position						

Table 1: Overview of settings 00-10/30 (■ = factory default)

- 1) At low running times, the maximum torque may not be reached.
- 2) Position which is approached when 4-20 mA signal is below 3 mA.
- 3) Stop ramp is only active in control mode.
- 4) If no "Enable" signal is present, 3-point step mode is active.
- 5) If no "Enable" signal is present, the drive is not moved.

Operation

Mode	Parameter									
	0	1	2	3	4	5	6	7	8	9
0	Idle / disabled	Manual movement	Analogue control with enable ⁴	3-point step with enable ⁵	Analogue control, ignore enable	3-point step, ignore enable	Manual movement, ignore limit switch	2-point	2-point with Interim position	
1	Analogue 4-20 mA	Analogue 2-10 V	Analogue 0-20 mA	Analogue 0-10 V						
2	Direction of rotation left	Direction of rotation right								
3 ^{1,6}	Torque 6 Nm	Torque 6.5 Nm	Torque 7 Nm	Torque 7.5 Nm	Torque 8 Nm	Torque 8.5 Nm	Torque 9 Nm	Torque 10 Nm	Torque 11 Nm	Torque 12 Nm
4 ²	Position 0% without triggering error relay	Stop at current position	Safe position 0%	Safe position 10%	Safe position 20%	Safe position 30%	Safe position 50%	Safe position 70%	Safe position 90%	Safe position 100%
5 ⁶	Running time 90 s / 90°	Running time 80 s / 90°	Running time 70 s / 90°	Running time 65 s / 90°	Running time 60 s / 90°	running time 50 s / 90°	Running time 45 s / 90°	Running time 40 s / 90°	Running time 30 s / 90°	Running time 25 s / 90°
6	Average 0 sec	Average 0.1 sec	Average 0.2 sec	Average 0.4 sec	Average 0.6 sec	Average 0.8 sec	Average 1.0 sec	Average 1.2 sec	Average 1.5 sec	Average 1.8 sec
7 ³	Start/stop ramp 0.05 sec	Start/stop ramp 0.2 sec	Start/stop ramp 0.4 sec	Start/stop ramp 0.6 sec	Start/stop ramp 0.8 sec	Start/stop ramp 1.0 sec	Start/stop ramp 1.2 sec	Start/stop ramp 1.5 sec	Start/stop ramp 2.0 sec	Start/stop ramp 2.5 sec
8	Hysteresis 0.05% / 90°	Hysteresis 0.08% / 90°	Hysteresis 0.1% / 90°	Hysteresis 0.2% / 90°	Hysteresis 0.4% / 90°	Hysteresis 0.6% / 90°	Hysteresis 0.8% / 90°	Hysteresis 1.0% / 90°	Hysteresis 1.5% / 90°	Hysteresis 2.0% / 90°
9	Configuring both end positions (potentiometer)	Configure end position "CCW" (potentiometer)	Configure end position "CW" (potentiometer)	Configure Interim position						

Table 2: Overview of settings 00-15/30 (■ = factory default)

- 1) At low running times, the maximum torque may not be reached.
- 2) Position which is approached when 4-20 mA or 2-10 V signal falls below 3 mA or 1.5 V.
- 3) Stop ramp is only active in control mode.
- 4) If no "Enable" signal is present, 3-point step mode is active.
- 5) If no "Enable" signal is present, the drive is not moved.
- 6) Other running time / torque combinations possible. See technical data.

Operation

Mode	Parameter									
	0	1	2	3	4	5	6	7	8	9
0	Idle / disabled	Manual movement	Analogue control with enable ⁴	3-point step with enable ⁵	Analogue control, ignore enable	3-point step, ignore enable	Manual movement, ignore limit switch	2-point	2-point with Interim position	
1	Analogue 4-20 mA	Analogue 2-10 V	Analogue 0-20 mA	Analogue 0-10 V						
2	Direction of rotation left	Direction of rotation right								
3 ^{1,6}	Torque 15 Nm	Torque 17 Nm	Torque 20 Nm	Torque 22 Nm	Torque 24 Nm	Torque 26 Nm	Torque 28 Nm	Torque 30 Nm	Torque 33 Nm	Torque 35 Nm
4 ²	Position 0% without triggering error relay	Stop at current position	Safe position 0%	Safe position 10%	Safe position 20%	Safe position 30%	Safe position 50%	Safe position 70%	Safe position 90%	Safe position 100%
5 ⁶	Running time 90 s / 90°	Running time 80 s / 90°	Running time 70 s / 90°	Running time 65 s / 90°	Running time 60 s / 90°	running time 50 s / 90°	Running time 45 s / 90°	Running time 40 s / 90°	Running time 30 s / 90°	Running time 25 s / 90°
6	Average 0 sec	Average 0.1 sec	Average 0.2 sec	Average 0.4 sec	Average 0.6 sec	Average 0.8 sec	Average 1.0 sec	Average 1.2 sec	Average 1.5 sec	Average 1.8 sec
7 ³	Start/stop ramp 0.05 sec	Start/stop ramp 0.2 sec	Start/stop ramp 0.4 sec	Start/stop ramp 0.6 sec	Start/stop ramp 0.8 sec	Start/stop ramp 1.0 sec	Start/stop ramp 1.2 sec	Start/stop ramp 1.5 sec	Start/stop ramp 2.0 sec	Start/stop ramp 2.5 sec
8	Hysteresis 0.05% / 90°	Hysteresis 0.08% / 90°	Hysteresis 0.1% / 90°	Hysteresis 0.2% / 90°	Hysteresis 0.4% / 90°	Hysteresis 0.6% / 90°	Hysteresis 0.8% / 90°	Hysteresis 1.0% / 90°	Hysteresis 1.5% / 90°	Hysteresis 2.0% / 90°
9	Configuring both end positions (potentiometer)	Configure end position "CCW" (potentiometer)	Configure end position "CW" (potentiometer)	Configure Interim position						

Table 3: Overview of settings 01-15/30 (■ = factory default)

- 1) At low running times, the maximum torque may not be reached.
- 2) Position which is approached when 4-20 mA or 2-10 V signal falls below 3 mA or 1.5 V.
- 3) Stop ramp is only active in control mode.
- 4) If no "Enable" signal is present, 3-point step mode is active.
- 5) If no "Enable" signal is present, the drive is not moved.
- 6) Other running time / torque combinations possible. See technical data.

Mode 1: Setting the analogue signal

The signal for the analogue input and output signal lines is selected:

Parameter 0: 4-20 mA

Parameter 1: 2-10 V (00-15 and 01-15 only)

Parameter 2: 0-20 mA

Parameter 3: 0-10 V (00-15 and 01-15 only)

Parameters 4-9: Not assigned; when selected, the current setting is not changed



Important:

The corresponding setting must also be made on the “Analogue” switch S15 (00-15 and 01-15 only).

Mode 2: Setting the direction of rotation

The direction of rotation is selected:

Parameter 0: Direction of rotation left. Valve closes counterclockwise (CCW) .

Parameter 1: Direction of rotation right. Valve closes clockwise (CW) .

Parameters 2-9: Not assigned; when selected, the current setting is not changed

Mode 3: Setting the torque

The torque is selected:

Parameters 0-9: Select the desired torque in 10 steps according to the “Settings” table.

The torques specified in the table are provided for guidance and are dependent on other operating parameters.

Mode 4: Setting the safe position in the event of a line break

If the input signal drops below 3 mA or 1.5 V in “control via external setpoint” mode (4-20 mA or 2-10 V), the drive can move to a desired safe position:

Parameter 0: Position 0% is approached. The “Ready for operation” relay will be switched in this case.

Parameter 1: Drive stops at current position. The “Ready for operation” relay is **not** switched in this case.

Parameters 2-9: Selected position 0% - 100% is approached in 8 steps. The “Ready for operation” relay is **not** switched in this case.

Mode 5: Setting the running time

The running time is selected:

Parameters 0-9: Select the desired running time in 10 steps according to the “Settings” table. The selected running time is always related to a swivel range of 90°.

Mode 6: Setting the averaging

The duration of the averaging process for the analogue setpoint input is selected. Higher durations will use more individual measurements for averaging. A higher setting can counteract any fluctuations in the input signal level.

Parameters 0-9: Selection of averaging in 10 steps from 0 s to 1.8 s.

Mode 7: Setting the ramp

Use this mode to select the duration of the start and hold ramps. In the three-point step and manual modes, the drive is always stopped immediately when the end positions are reached or when the move signal drops. The holding ramp is only used in control mode.

Parameters 0-9: Select the duration of the start and holding ramp in 10 steps from 0.05 s to 2.5 s.

Mode 8: Setting the step size / hysteresis

Use this to select the hysteresis.

In **control mode**, the hysteresis setting determines the level at which a change to the analogue input signal will cause the drive to readjust the position. This setting therefore has a direct effect on the resolution of the available steps in control mode. A stable and low-interference analogue input signal is required in order to set a fine-tuned hysteresis. The stability of the measurement of the analogue input signal can therefore also be influenced by the averaging (Mode 6: Setting the averaging) setting. With a very finely tuned hysteresis, the duration of the ramp (mode 7) must not be too short.

In **three-point step mode**, the hysteresis setting determines the level of precision with which the end positions are approached. The higher the hysteresis setting, the earlier the motor is switched off when an end position is reached.

In **three-point step mode and control mode**, this setting also determines the hysteresis of the end position relays.

Parameters 0-9: Select the hysteresis in 10 steps from 0.05% to 2.0%. The values refer to an opening angle of 90°.

Mode 9: Setting the end positions

(Images for drive 00-15 as reference)

The position is determined by the electronic control of the drive using a potentiometer mounted on the CPU board. The potentiometer is connected to the output shaft without play. The positions of the two end positions are also determined by the electronics via the potentiometer.

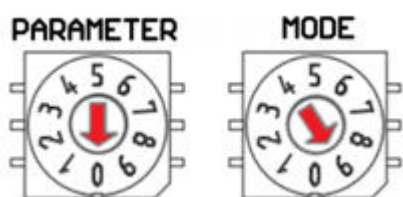

The scalings used for the external setpoint input and the position feedback automatically adapt to the newly set positions for the end positions.

Parameter 0: Configuration of both end positions



Mode: 9
Parameter: 0
Configuration of both end positions



Use the  and  buttons to move to the first end position. It is irrelevant whether the minimum or maximum end position is approached first. The  LED will flash.

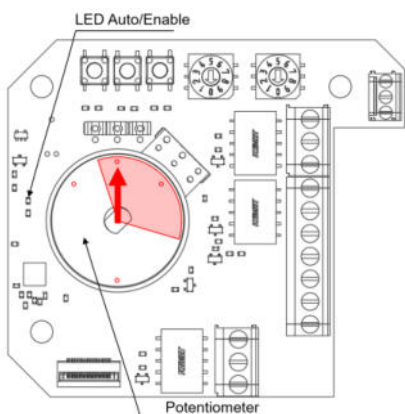

The potentiometer P1, which is responsible for determining the position, has a permissible range of motion of approx. 110°. It must be ensured that the end position does not lie outside the permissible range of motion of the drive. The permissible range of motion of the potentiometer is shaded in red. There are four markings on the potentiometer; these are shown as red circles in the adjacent illustration. The marking indicated with an arrow must always be within the shaded area. The "Enable" LED must not light up. If the current position is outside the valid range, the "Enable" LED will flash twice.





Press and hold the “Prog” button to set the first end position. The “Prog” LED will flash briefly.

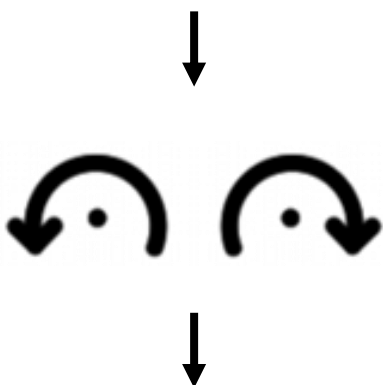

Use the ↻ and ↺ buttons to move to the second end position. The ↻ LED will flash.

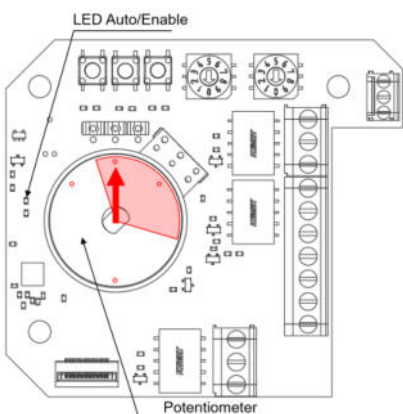

Once again, ensure that the end position does not lie outside the permissible range of motion of the drive.



Press and hold the “Prog” button to set the new end position values. The “Prog” LED will flash briefly.

Parameter 1: Configure individual end position “CCW”

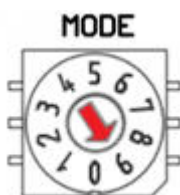
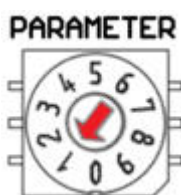

Mode: 9



Parameter: 1

This menu item is used to set a single end position in case only one of the two end positions needs to

be changed. If both end positions have to be adjusted, parameter 0 must be selected.

Setting the end position that is opposite the other end position in the counterclockwise direction (CCW).



Use the  and  buttons to move to the “CCW” end position. The  LED will flash. In the example, the end position to be set is shown as a red arrow and the second end position as a blue arrow. Ensure that the end position does not lie outside the permissible range of motion of the drive. The “Enable” LED must not light up. If the current position is outside the valid range, the “Enable” LED will flash twice. There are four markings on the potentiometer; these are shown as red circles in the adjacent illustration. The permissible range of motion of the potentiometer is shaded in red. The marking indicated with an arrow must always be within the shaded area.

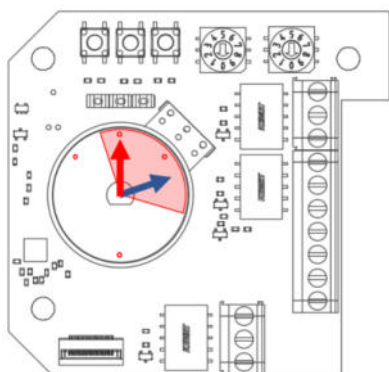

Press and hold the “Prog” button to set the CCW end position. The “Prog” LED will flash briefly.

Parameter 2: Configure individual end position “CW”



Mode: 9

Parameter: 2

This menu item is used to set a single end position in case only one of the two end positions needs to be changed. If both end positions have to be adjusted, parameter 0 must be selected.

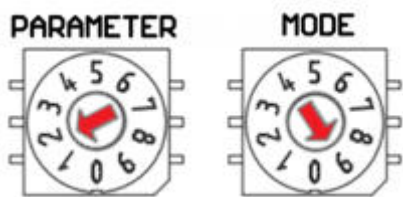
Setting the end position that is opposite the other end position in the clockwise direction (CW).



Use the  and  buttons to move to the “CW” end position. The  LED will flash. In the example, the end position to be set is shown as a red arrow and the second end position as a blue arrow.

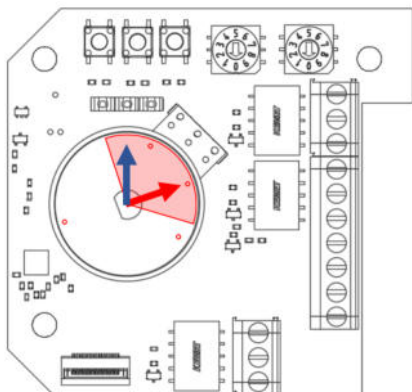

Ensure that the end position does not lie outside the permissible range of motion of the drive. The “Enable” LED must not light up. If the current position is outside the valid range, the “Enable” LED will flash twice. There are four markings on the potentiometer; these are shown as red circles in the adjacent illustration. The permissible range of motion of the potentiometer is shaded in red. The marking indicated with an arrow must always be within the shaded area.





Press and hold the “Prog” button to set the CW end position. The “Prog” LED will flash briefly.

Parameter 3: Configure the intermediate position (Two-point mode with intermediate position):

Mode: 9

Parameter: 3

The menu item is used to set the intermediate position for the operating mode "two-point with intermediate position".

Use the  and  buttons and to move to the desired position. Ensure that the position does not lie outside the permissible range of motion of the drive. The "Enable" LED must not light up. If the current position is outside the valid range, the "Enable" LED will flash twice.

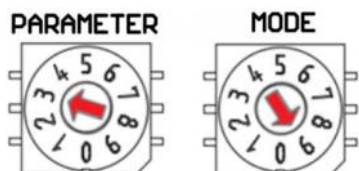



Press and hold the "Prog" button to set the position. The "Prog" LED will flash briefly.

Parameters 4-9: Not assigned; when selected, the current setting is not changed

Configuration mode 2

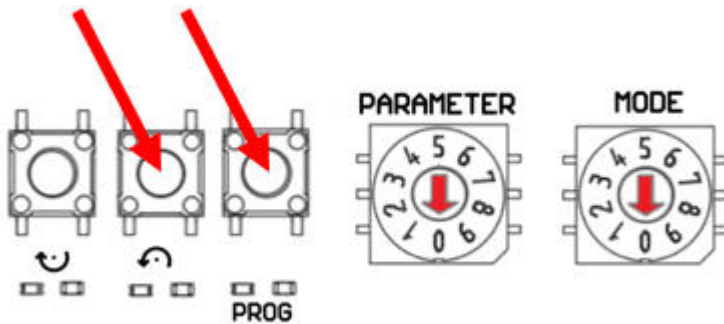
Set the actuator to **configuration mode 2** if you want to change any other settings. To set the actuator to **configuration mode 2** while it is already running, set the Mode and Parameter rotary switches to “0”, then press and hold the  and “PROG” buttons at the same time.



You can also set the actuator to **configuration mode 2** as you turn it on (apply a voltage) by pressing the  button with the Mode and Parameter rotary switches set to “0”.

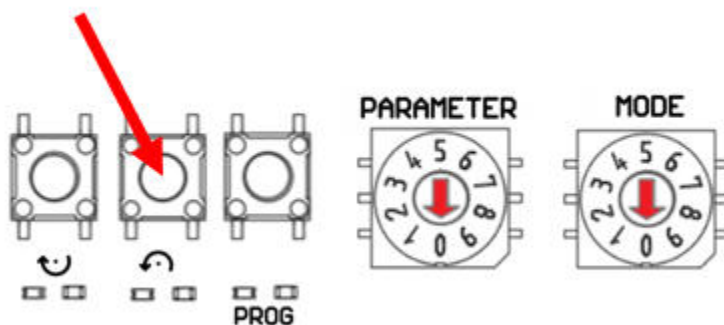

The “PROG” LED and the “Enable” LED will be on. The “Ready for operation” relay is not switched. You can then use the Parameter rotary switch to select different settings. Press and hold the “Prog” button to save your settings. The “Prog” LED will flash briefly to show that your settings have been saved.

To exit **configuration mode 2**, set the Mode and Parameter rotary switches back to “0”, then press and hold the “Prog” button. The “Prog” LED will flash briefly. The actuator will then return to standard mode.

An overview of the different options available for the parameters is provided in the table below:

Operation

Mode	Parameter									
	0	1	2	3	4	5	6	7	8	9
0	Return to standard mode									
1	Test LEDs	Validate current settings								
2	Analogue output Calibrate current	Analogue output Calibrate voltage								
3	Analogue input current 4 mA calibrate value	Analogue input voltage 2 V - calibrate value ¹								
4	Analogue input current 20 mA - calibrate value	Analogue input voltage 10 V - calibrate value ¹								
5										
6	Motion									
7	Heating off	Heating on 0°	Heating on 5°							
8	Restore factory settings									
9										

Table 4: Configuration mode 2 settings

1) 00-15 and 01-15 only



Mode 0: Return to standard mode

Parameter 0: Press and hold the “Prog” button to return the drive to standard mode.

Parameters 1-9: Not assigned; when selected, the current setting is not changed

Mode 1: Test

Parameter 0: The following LEDs are configured to stay on. They can be used to determine if the device is working properly:

- LED , green
- LED , green
- “PROG” LED, red
- “Power” LED, green
- “Enable” LED, green
- “Error” LED, red

Parameter 2: A plausibility check is performed for all settings. If an error is found in any of the settings, the “Ready for operation” relay output drops out and the “Error” LED will turn on. The flashing sequence of the “Auto/Enable” LED will indicate an error number.

Flashing	Error description
2x	Drive position is outside the permissible range of motion
3x	Operating data setting error detected (analogue signal, direction of rotation, torque, safe position, running time, averaging, ramp, hysteresis or heating)
4x	Setting error detected in potentiometer calibration values
5x	Setting error detected in analogue output calibration values
6x	Setting error detected in analogue input calibration values
7x	General settings error

Incorrect settings are not corrected automatically. For example, the system checks whether the 4 mA calibration value is lower than the 20 mA calibration value for the analogue interface. It does not, however, check if the 4 mA calibration value is within the range of 8 mA.

Parameters 2-9: Not assigned; when selected, the current setting is not changed

Mode 2: Calibrate analogue output

The analogue output of the drive is calibrated at the factory. Recalibrating the analogue output is usually only necessary if there are very high requirements for angular accuracy or, for example, if the connection cables are long.

Two calibration values can be adjusted in current or voltage mode for the calibration characteristic curve of the analogue output. In current mode, the calibration values for 4 mA and 20 mA can be adjusted. In voltage mode, the calibration values for 2 V and 10 V can be adjusted.

Parameter 0: Calibrate analogue output current

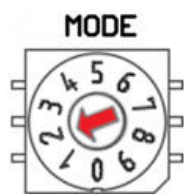
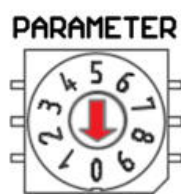

Mode: 2

Parameter: 0

Calibrate analogue output current

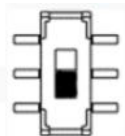
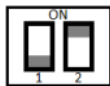



Set "Analogue" switch S15 to current mode
(Version S15 depending on the device revision)

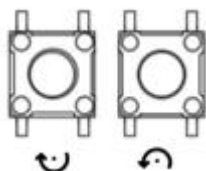

Connect current meter to analogue output
(terminals 1 and 2)



+ -

The current 4 mA value is output. The displayed value must be set to 4 mA as accurately as possible. The value can be decreased using the  button and increased using the  button.



Wait until the value is stable.

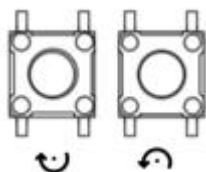
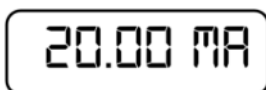

Press and hold the “Prog” button to set the value. The “Prog” LED will flash briefly.



+ -

The current 20 mA value is output. The displayed value must be set to 20 mA as accurately as possible. The value can be decreased using the  button and increased using the  button.

Wait until the value is stable.

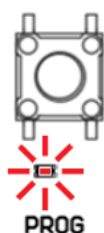

Press and hold the “Prog” button to store the new calibration values for 4 and 20 mA in the memory. The “Prog” LED will flash briefly.

Parameter 1: Calibrate analogue output voltage

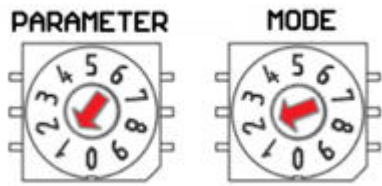

Mode: 2

Parameter: 1

Calibrate analogue output voltage

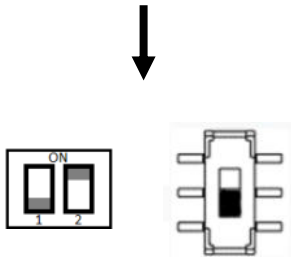



Set "Analogue" switch S15 to voltage mode
(Version S15 depending on the device revision)

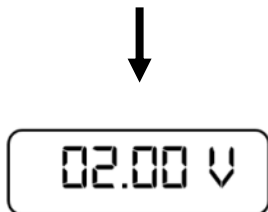

Connect voltmeter to analogue output (terminals 1 and 2)



The current 2 V value is output. The displayed value must be set to 2 V as accurately as possible. The value can be decreased using the  button and increased using the  button.

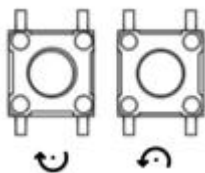



+ -



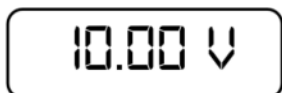

Press and hold the “Prog” button to set the value.
The “Prog” LED will flash briefly.



The current 10 V value is output. The displayed value must be set to 10 V as accurately as possible. The value can be decreased using the  button and increased using the  button.

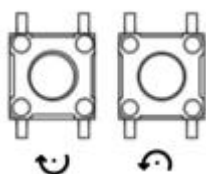

+ -



Press and hold the “Prog” button to store the new calibration values for 2 and 10 V in the memory.
The “Prog” LED will flash briefly.

Parameters 2-9: Not assigned; when selected, the current setting is not changed

Mode 3: Calibrate analogue input 4 mA or 2 V value

The analogue input of the drive is calibrated at the factory. Recalibrating the analogue input is usually only necessary if there are very high requirements for angular accuracy or, for example, if the connection cables are long.

Two calibration values can be adjusted in current or voltage mode for the calibration characteristic curve of the analogue input. In current mode, the calibration values for 4 mA and 20 mA can be adjusted. In voltage mode, the calibration values for 2 V and 10 V can be adjusted.

In the **Mode 3** setting, the calibration values are adjusted for 4 mA or 2 V.



Important:

The corresponding setting must also be made on the “Analogue” switch S15.

Parameter 0: 4 mA is applied to the analogue input from a current source. Press and hold the “Prog” button to store the new calibration values for 4 mA in the memory. The “Prog” LED will flash briefly. If the new value is outside the valid range, the new value cannot be stored in the memory (the “Prog” LED will not flash).

Parameter 1: 2 V is applied to the analogue input from a voltage source. Press and hold the “Prog” button to store the new calibration values for 2 V in the memory. The “Prog” LED will flash briefly. If the new value is outside the valid range, the new value cannot be stored in the memory (the “Prog” LED will not flash).

Parameters 2-9: Not assigned; when selected, the current setting is not changed

Mode 4: Calibrate analogue input 20 mA or 10 V value

The analogue input of the drive is calibrated at the factory. Recalibrating the analogue input is usually only necessary if there are very high requirements for angular accuracy or, for example, if the connection cables are long.

Two calibration values can be adjusted in current or voltage mode for the calibration characteristic curve of the analogue input. In current mode, the calibration values for 4 mA and 20 mA can be adjusted. In voltage mode, the calibration values for 2 V and 10 V can be adjusted.

In the **Mode 4** setting, the calibration values are adjusted for 20 mA or 10 V.



Important:

The corresponding setting must also be made on the “Analogue” switch S15.



Parameter 0: 20 mA is applied to the analogue input from a current source. Press and hold the “Prog” button to store the new calibration values for 20 mA in the memory. The “Prog” LED will flash briefly. If the new value is outside the valid range, the new value cannot be stored in the memory (the “Prog” LED will not flash).

Parameter 1: 10 V is applied to the analogue input from a voltage source. Press and hold the “Prog” button to store the new calibration values for 10 V in the memory. The “Prog” LED will flash briefly. If the new value is outside the valid range, the new value cannot be stored in the memory (the “Prog” LED will not flash).

Parameters 2-9: Not assigned; when selected, the current setting is not changed

Mode 5: Not used

Mode 6: Motion

Parameter 0: The drive can be moved using the  and  buttons. The rotary movement does not take into account the position of the limit switches. This mode is for testing the movement of the drive. If the current position is outside the **valid range of motion**, the “Enable” LED will flash twice.

The drive will rotate using running time setting 8.

Parameters 1-9: Not assigned; when selected, the current setting is not changed

Mode 7: Setting the heating

If required, a heater integrated into the drive can be switched on. This does not require any additional power compared to the maximum power specified in the technical specifications.

Parameter 0: The heating is deactivated.

Parameter 1: The heating is activated as soon as the temperature in the device falls below 0°C.

Parameter 2: The heating is activated as soon as the temperature in the device falls below 5°C.

Parameters 3-9: Not assigned; when selected, the current setting is not changed

Mode 8: Restore factory settings

Parameter 0: Press and hold the “Prog” button to reset all operating data (analogue signal, direction of rotation, torque, safe position, running time, averaging, ramp, hysteresis or heating) and also the calibration data to the factory settings. The “Prog” LED will flash briefly.



Important: This cannot be undone.

Parameters 1-9: Not assigned; when selected, the current setting is not changed

Mode 9: Not used

Error management

Error signalling

If the drive is not ready for operation or if there is an error, the “Ready for operation” relay output will drop out. The “Error” LED will also turn on. In certain cases, the “Enable” LED will flash in a particular sequence to indicate an error number for troubleshooting.

A list of the modes or error states in which the “Ready for operation” relay output drops out is provided below:

- The drive is in configuration mode
- The drive is in “idle” mode, “manual movement” mode or “manual movement, ignore limit switch” mode
- There is no voltage being supplied to the drive (in this case, the “Error” LED will not turn on).
- One of the following errors has occurred:
 - o Excess heat: The temperature in the drive has risen to over 70°C. In this case, the drive will continue to move.
 - o Analogue input line break: In this case, the drive will behave in line with the setting “Mode 4: Safe position in the event of a line break”.
 - o Motor error (e.g. blockage), see the section “Motor monitoring” below.
 - o Error detected in plausibility check, see the section “Plausibility check” below.
 - o Position measured at the potentiometer is outside the valid range; the “Enable” LED will flash twice for troubleshooting.

Motor monitoring

As soon as the motor starts rotating, the drive continuously monitors the speed of the drive unit and checks for blockages. The drive will attempt to correct any issues itself:

- If the motor is blocked for more than 10 s or if the current speed deviates significantly from the set speed for more than 10 s, the “Ready for operation” relay output will drop out and the “Error” LED will turn on.

- If the motor is blocked for more than 10 s or if the current speed deviates significantly from the set speed for more than 20 s, the drive will restart.
- If the motor is blocked for more than 10 s or if the current speed deviates significantly from the set speed for more than 10 s while the drive is moving towards one of the end positions (current position is at most five times the distance of the hysteresis setting from one of the end positions), the drive will stop moving. The “Ready for operation” relay output will drop out and the “Error” LED will turn on.

If the problem cannot be solved automatically, check the system for errors. The actuator may be physically blocked.

There is no motor monitoring in the manual operating modes.

Plausibility check

Each time the system is started, the actuator performs a plausibility check for all of the settings. Any error that is found in any of the settings will be automatically corrected if possible, for example by resetting to factory settings. The “Ready for operation” relay output will drop out and the “Error” LED will turn on. The flashing sequence of the “Auto/Enable” LED will indicate an error number. This signal will remain visible until the next system start and will override the signals normally associated with standard mode.

Flashing	Error description
2x	Drive position is outside the permissible range of motion
3x	Operating data setting error detected (analogue signal, direction of rotation, torque, safe position, running time, averaging, ramp, hysteresis or heating)
4x	Setting error detected in potentiometer calibration values
5x	Setting error detected in analogue output calibration values
6x	Setting error detected in analogue input calibration values
7x	General settings error

For example, the system checks whether the 4 mA calibration value is lower than the 20 mA calibration value for the analogue interface. It does not, however, check if the 4 mA calibration value is within the range of 8 mA.

Troubleshooting

Error	Possible cause	Solution
"Ready for operation" relay is not active	The drive is in configuration mode	Change to standard mode
	The drive is in "idle" mode, "manual movement" mode or "manual movement, ignore limit switch" mode	Change to another mode
	No supply voltage to the drive	Check the connection cables for the supply voltage
	Excess heat: The temperature in the drive is over 70°C.	Let the drive cool down.
	Analogue input line break	Check the connection cables of the analogue input
	Motor error (e.g. blockage)	Check the drive as well as the actuator for a blockage. If necessary, increase the "Torque" setting. If necessary, increase the "Ramp" setting. Check whether the end positions are set correctly. Check the actuator for dirt or deposits.
	The position is outside the permitted range	Return the position to the permitted range in manual mode.

Error	Possible cause	Solution
	Error found during plausibility check	Check the individual setting based on the flashing sequence of the "Enable" LED. See the section "Plausibility check"
The drive continuously corrects the current position in control mode.	Fluctuations in the analogue input signal	Check the analogue input signal. If necessary, increase the "Hysteresis" setting. If necessary, increase the "Averaging" setting.
The analogue output does not show the expected values.	The settings for the analogue signal are not set correctly.	If necessary, adjust the "Analogue signal" setting. If necessary, adjust the "Analogue signal" setting of the switch S15. If necessary, calibrate the analogue output.
The drive does not move in the operating modes "control with setpoint enabling" (parameter 2) or "three-point step with enabling" (parameter 3).	There is no enable signal at terminal 12.	Check the enable signal. The "Enable" LED can also be used for this purpose. If necessary, change to a mode without an enable signal.

Technical specifications

	00-10/30 STEP	00-15/30 STEP	01-15/30 STEP
Max. torque [Nm]	4 Nm adjustable	12 Nm adjustable	35 Nm adjustable
Running time	15-60 s / 90° adjustable	25-90 s / 90° adjustable	25-90 s / 90° adjustable
Other possible variants (torque / running time)		6 Nm / 12-45s/90° 3 Nm / 7,5-25s/90°	18 Nm / 12-45s/90° 9 Nm / 7,5-25s/90°
Max. angle of rotation	110°		
Voltage DC version	18..30 VDC		
Voltage AC version	90..260 VAC, 50/60 Hz		
Power consumption	DC : max. 4,8 W (24V) AC : max. 5 VA	DC : max. 6 W (24V) AC : max. 7 VA	DC : max. 11 W (24V) AC : max. 15 VA
Protection class	IP65		
Ambient temperature [°C]	-20°C to 60°C		
Weight	~ 0.8 kg	~ 1.6 kg	~ 2.2 kg
Dimensions	~ 114 x 82 x 93 mm	~ 135 x 108 x 122 mm	~ 176 x 111 x 142 mm
Cable entry	3x M16 x 1.5 mm Ø: 5-9 mm	2x M20 x 1.5 mm Ø: 9-13 mm	2x M20 x 1.5 mm Ø: 9-13 mm
Housing	Cast aluminium		
Output shaft [mm]	7x7x7.5 mm square socket	9x9x9.5 mm square socket	9x9x9.5 mm square socket
Adapters	F03, LKØ36 8xM5 and LKØ50 2xM6	F03, F05 and LKØ50 8xM6	F07 and LKØ50 4xM5, LKØ50 4xM6
Service life	500,000 cycles at full load, 2,000,000 cycles at 60% load		
Operating modes	<ul style="list-style-type: none"> • Manual • Automatic: 3-point step • Automatic: 2-point • Automatic: Electronic control • Switching between manual mode, control mode or 3-point step using rotary switch or based on control enable signal 		
Operating mode: Manual	<ul style="list-style-type: none"> • Manual operation using open & close buttons 		
Operating mode: Automatic 3-point step	<ul style="list-style-type: none"> • Open & close via potential-free inputs • Enable signal • Adjustable start ramp 		
Operating mode: Automatic 2-point	<ul style="list-style-type: none"> • Open & close via potential-free input • Adjustable start ramp 		
Operating mode: Automatic 2-point with Interim position	<ul style="list-style-type: none"> • Open & close via potential-free input • Interim position via potential-free input • Adjustable start ramp 		

Technical specifications

	00-10/30 STEP	00-15/30 STEP	01-15/30 STEP
Operating mode: Automatic electronic control	<ul style="list-style-type: none"> Electronic control: Input 0/4-20 mA Up to 1000 steps/90° Adjustable step size Adjustable averaging for analogue input Adjustable safe position Enable signal Adjustable ramp 	<ul style="list-style-type: none"> Electronic control: Input 0/4-20 mA, 0/2-10 V Up to 1000 steps/90° Adjustable step size Adjustable averaging for analogue input Adjustable safe position Enable signal Adjustable ramp 	
Position feedback	Analogue output 0/4-20 mA	Analogue output 4-20 mA, 0/2-10 V	
Position feedback		<ul style="list-style-type: none"> Current value transmitter (optional): Potentiometer 0-1 KΩ or 0-5 KΩ 	
Feedback outputs	<ul style="list-style-type: none"> 2x end position relays potential-free min/max Optional 2x freely adjustable cam switches, potential-free 1x status relay output potential-free 		<ul style="list-style-type: none"> 2x end position relays potential-free min/max Optional 3x freely adjustable cam switches, potential-free 1x status relay output potential-free
Electrical specifications of the inputs and outputs	<p>Position feedback analogue:</p> <ul style="list-style-type: none"> Current source: Max. output voltage 12 V, max. load 500 Ω Voltage source: Max. output voltage 12 V, max. current 30 mA <p>Setpoint input analogue:</p> <ul style="list-style-type: none"> Max. input voltage: 12 V, current input: Load: 500 Ω <p>Relay outputs:</p> <ul style="list-style-type: none"> AC switching capacity: Max. 250 V, 500 mA, resistive load DC switching capacity: max. 220 V, 500 mA, resistive load <p>Cam switch:</p> <ul style="list-style-type: none"> AC switching capacity: Max. 250 V, 500 mA, resistive load Max. 250 V, 250 mA, inductive load DC switching capacity: 30 V, 1000 mA, resistive load Max. 125 V, 100 mA, resistive load 30 V, 500 mA, resistive load Max. 125 V, 30 mA, resistive load <p>3-point step, enable signal inputs:</p> <ul style="list-style-type: none"> AC version: 90..260 V AC, max. current 5 mA DC version: 18..30 V, max. current 10 mA 		
Other product features	<ul style="list-style-type: none"> Mechanical position indicator in the cover Heating with thermostat 		

Declaration of Conformity

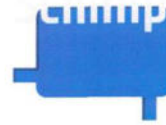

EU-Konformitätserklärung

EU Declaration of Conformity
Déclaration de Conformité UE

Wir **Antriebs-&Regeltechnik Schimpf GmbH, Bonholzstrasse 17, D-71111 Waldenbuch**

We / Nous

erklären, dass das Produkt **alle Regelantriebe der Serie 00-01-02-03-04**
declare that product / déclarons que produit

inklusive **technisches Zubehör**
inclusive / ycompris

auf welche sich diese Erklärung bezieht, mit den folgenden Norm(en) übereinstimmt
to which this declaration relates conforms to the following standard(s)
sur laquelle cette déclaration se réfère, et conformément aux dispositions de la norme(s)

DIN EN 16340: 2014-10
DIN EN 60730-1: 2021-06

gemäß den Bestimmungen der folgenden Richtlinie(n).
according to the provisions of the following directive(s) / conformément aux dispositions de la directive(s)

Nummer (Number / Numéro)	Text (Text / Texte)
2014/35/EU 2014/35/EU/ 2014/35/UE	Niederspannungsrichtlinie Low Voltage Directive Directive basse tension
2014/30/EU 2014/30/EU/ 2014/30/UE	EMV-Richtlinie EMC Directive Directive CEM
2011/65/EU 2011/65/EU/ 2011/65/UE	RoHS RoHS RoHS

Das Datenblatt und gegebenenfalls die Basisdokumentation sind zu beachten.
The data sheet and basic documentation, if any, have to be considered.
La consultation de la fiche technique, et éventuellement de la documentation technique de base, est requise.

Hinweise zur Anwendung der Richtlinie 2014/30/EU:

Die Konformität mit 2014/30/EU gilt für die Verwendung in industrieller Umgebung.

Remarks regarding the application of directive 2014/30/EU:
Conformity with 2014/30/EU only in industrial environment.

Remarques sur l'application des directives 2014/30/UE:
La conformité avec la 2014/30/UE est valable dans un environnement industrielle

Anbringung der CE-Kennzeichnung: **ja**
Placing of the CE marking / L'apposition du marquage CE

Rechtsverbindliche Unterschrift
Authorized signature / Signature autorisée

Waldenbuch, 29.03.2022
Antriebs- & Regeltechnik
N. Geiger, Geschäftsführung
Bonholzstr. 17
71111 Waldenbuch
Telefon 07157/52755-0

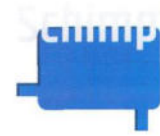

UK-Konformitätserklärung

UK Declaration of Conformity
Déclaration de Conformité UK

Wir
We / Nous
erklären,
declare /
déclarons

Antriebs-&Regeltechnik Schimpf GmbH, Bonholzstrasse 17, D-71111 Waldenbuch

dass das Produkt
that product / que produit
alle Regelantriebe der Serie 00-01-02-03-04
all actuating drive of the series 00-01-02-03-04 / tous les actionneurs de la série 00-01-02-03-04

auf welche sich diese Erklärung bezieht, mit den folgenden Norm(en) übereinstimmt
to which this declaration relates conforms to the following standard(s)
sur laquelle cette déclaration se réfère, et conformément aux dispositions de la norme(s)

EN 16340: 2014-10
EN 60730-1: 2021-06

gemäß den Bestimmungen der folgenden UK-Richtlinie(n).
according to the provisions of the following UK act(s) / conformément aux dispositions de la directive(s)

Nummer (Number / Numéro)	Text (Text / Texte)
UK SI 2016 No. 1101 and amendments	The Electrical Equipment (Safety) Regulations 2016
UK SI 2016 No. 1091 and amendments	The Electromagnetic Compatibility Regulations 2016
UK SI 2012 No. 3032 and amendments	The Restriction of the Use of Certain Hazardous Substances in Electrical and Electronic Equipment Regulations 2012

Das Datenblatt und gegebenenfalls die Basisdokumentation sind zu beachten.
The data sheet and basic documentation, if any, have to be considered.
La consultation de la fiche technique, et éventuellement de la documentation technique de base, est requise.

Hinweise zur Anwendung der Richtlinie UK SI 2016 No. 1091:
Die Konformität mit UK SI 2016 No. 1091 gilt für die Verwendung in industrieller Umgebung.

Remarks regarding the application of directive UK SI 2016 No. 1091:
Conformity with UK SI 2016 No. 1091 only in industrial environment.

Remarques sur l'application des directives UK SI 2016 No. 1091:
La conformité avec la UK SI 2016 No. 1091 est valable dans un environnement industrielle

Anbringung der UKCA-Kennzeichnung: **ja, yes, oui**
Placing of the UKCA marking / L'apposition du marquage UKCA

Waldenbuch, 20.01.2023
N. Geiger, Geschäftsführer, Managing Director, Directeur général

Rechtsverbindliche Unterschrift
Authorized signature / Signature autorisée

Antriebs- & Regeltechnik
Schimpf GmbH
Bonholzstr. 17
71111 Waldenbuch
Telefon 07157/52756-0

Dimensional drawings

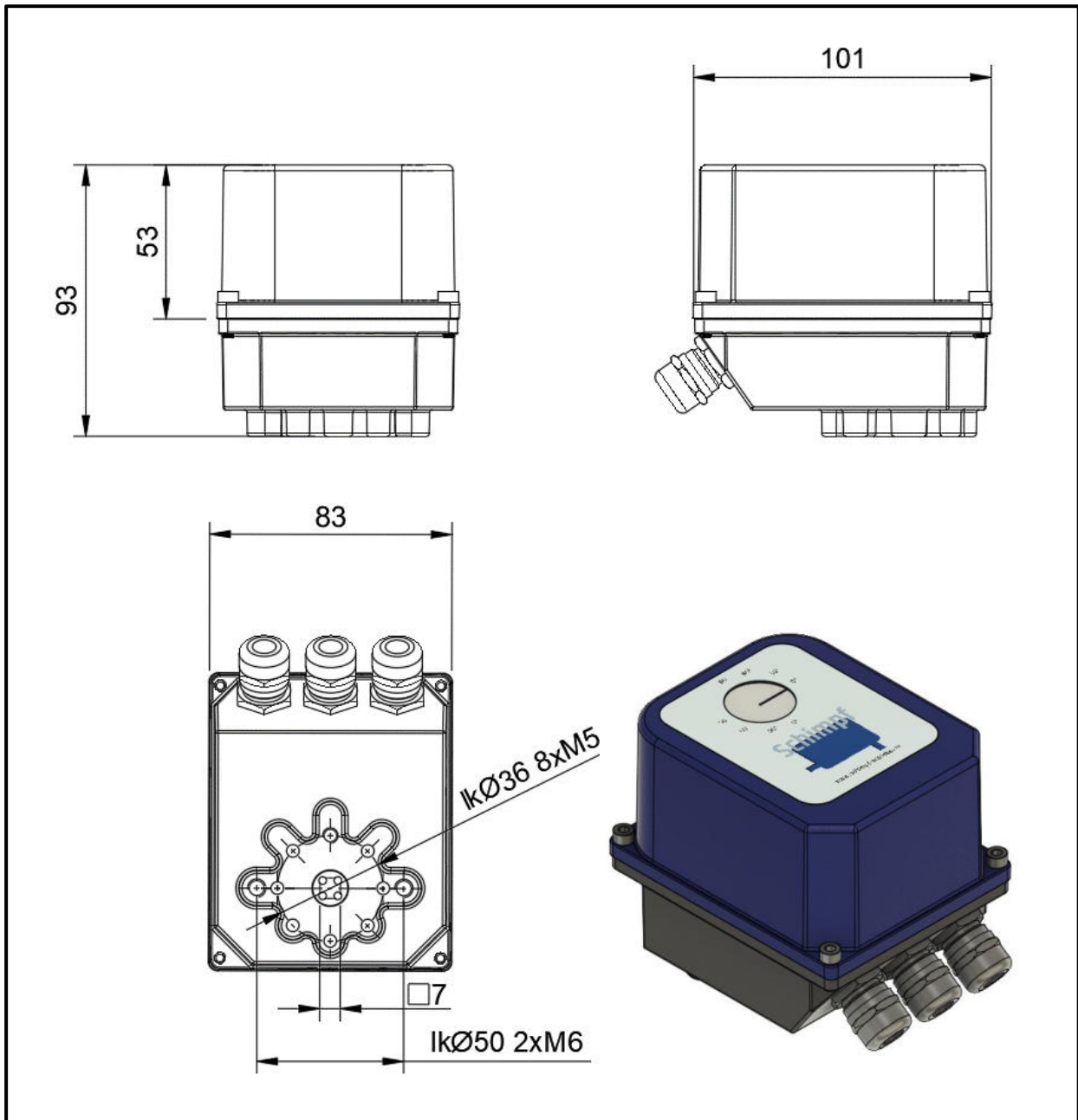

Figure 14: Dimensions of drive type 00-10

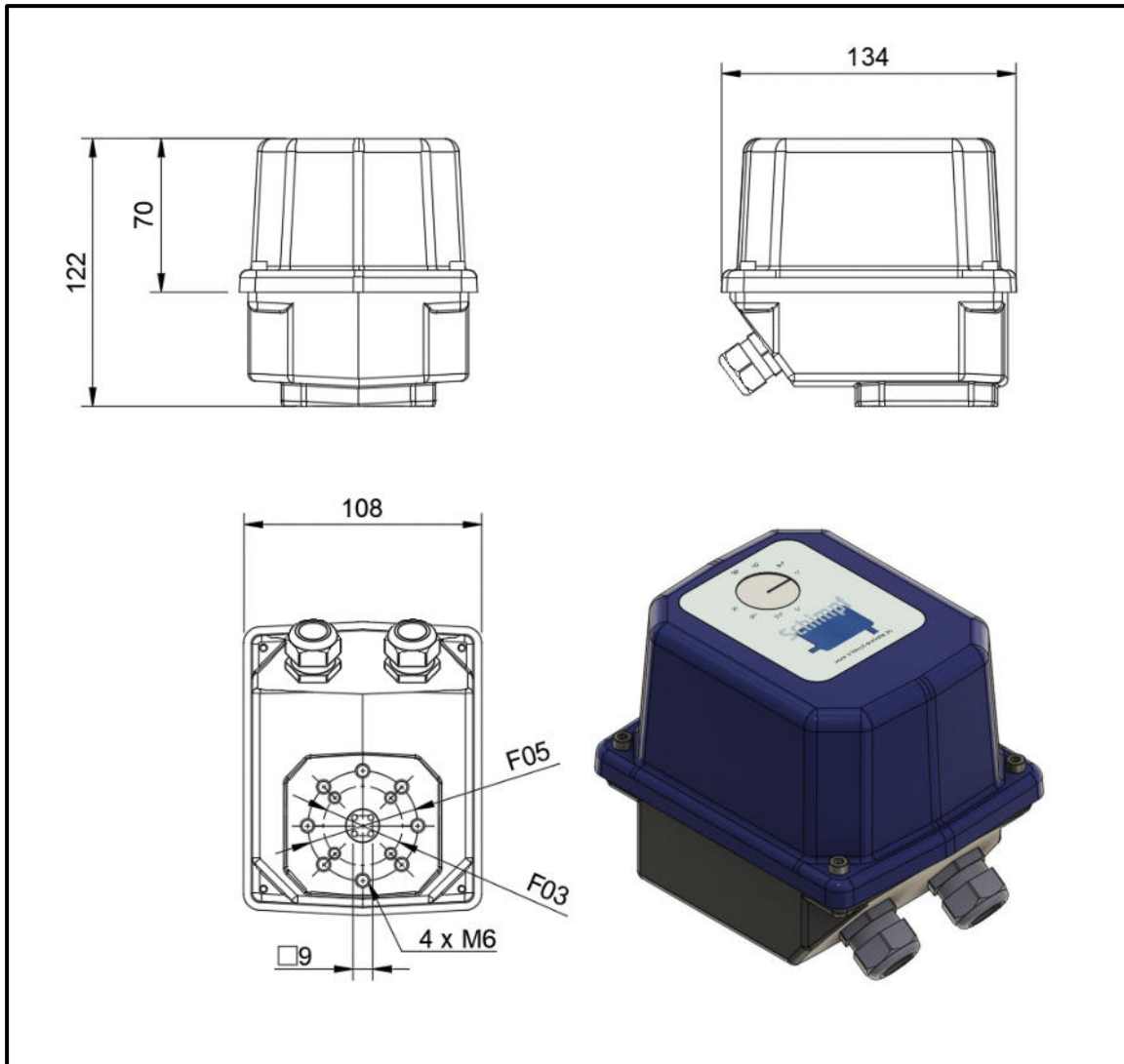

Figure 15: Dimensions of drive type 00-15

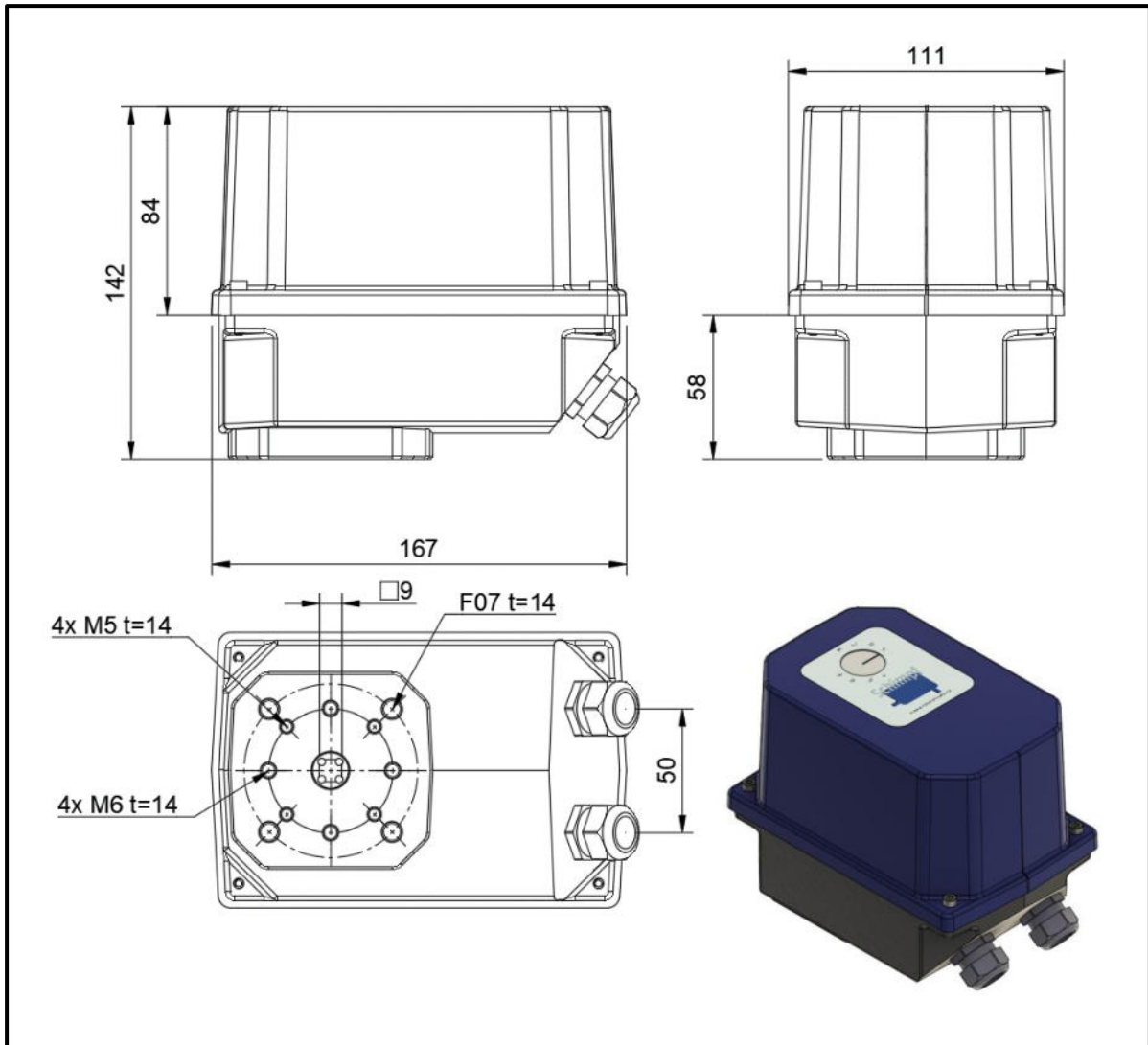

Figure 16: Dimensions of drive type 01-15

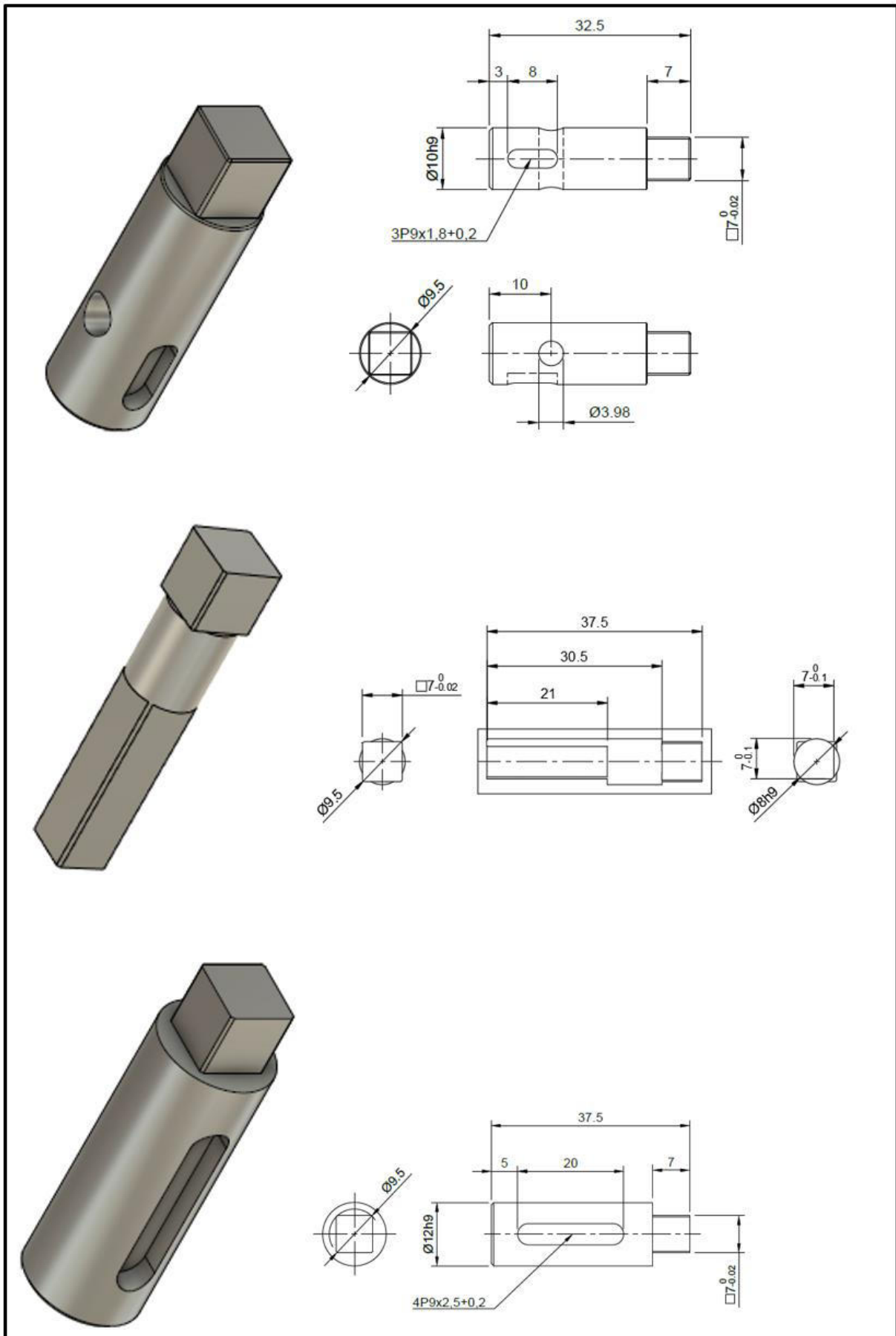

Figure 17: Shaft end configurations square 7x7 (optional accessory for 00-10)

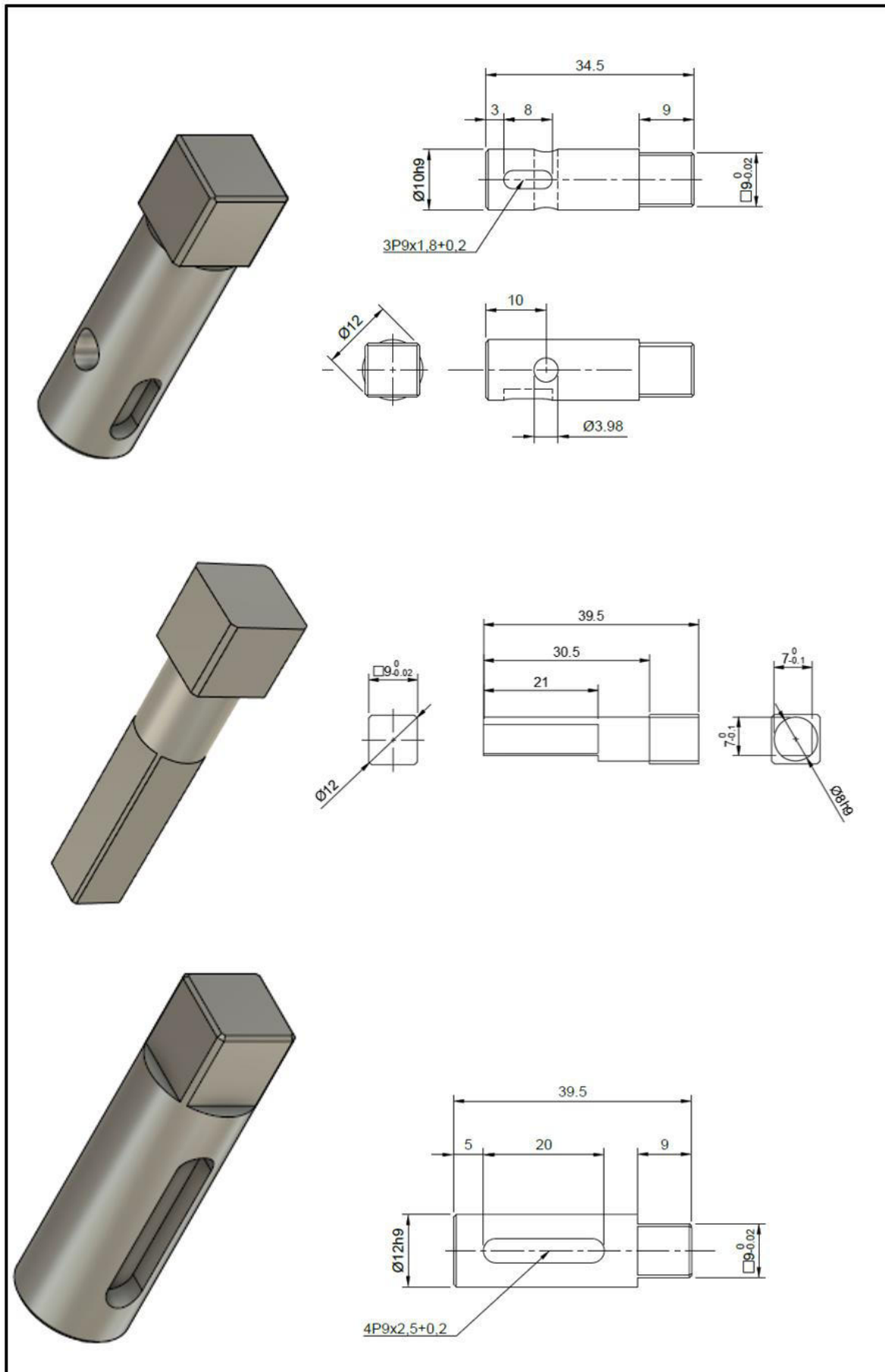

Figure 18: Shaft end configurations square 9x9 (optional accessory for 00-15 and 01-15)

Notes

The table below serves to record the set parameters when commissioning the drive. If necessary, it is easier to refer to this data.

Configuration setup:			
No.	Mode Description	Parameter preset	Comment
0	Operation mode		
1	Analog signal		
2	Rotation direction		
3	Max. torque		
4	Behaviour in the event of analogue control loss		
5	Running time		
6	Analog signal averaging		
7	Start/ stop ramp		
8	Hysteresis		
9	Min/ max position adjustment		
