

CTJ

CHARACTERISTICS

The **CTJ** series includes Linear Units with a toothed belt drive and two parallel, integrated, Zero-backlash rail guides. Compact dimensions allow high performance features such as, high speed and repeatability. They can easily be combined to multi-axis systems.

Excellent price-/performance ratio and quick delivery time are ensured.

A compact, precision-extruded aluminum Profile from AL 6063, with two parallel, integrated Zero-backlash rail guide systems, allows high load capacities and an optimal sequence for the movement of larger masses at high speed.

In the linear units CTJ is used a pre-tensioned steel reinforced AT polyurethane timing toothed belt. In conjunction with a Zero-backlash drive pulley high moments with alternating loads with good positioning accuracy, low wear and low noise can be realized.

The in the Profile slot driving Polyurethane timing belt, protects all the parts in the Profile from dust and other contaminations.

Different carriage lengths with lubrication port allows for easy re-lubrication of the Ball rail guide system and allows the possibility to attach additional accessories. The re-lubrication can also be done through maintenance holes on the side of the Profile.

The aluminum profile includes T-slots for fixing the Linear Unit and for attaching sensors and switches. Also, a Reed switch can be used here.

For the linear units CTJ various adaptation options, for attaching (or redirecting), for Motors or Gearboxes are available.

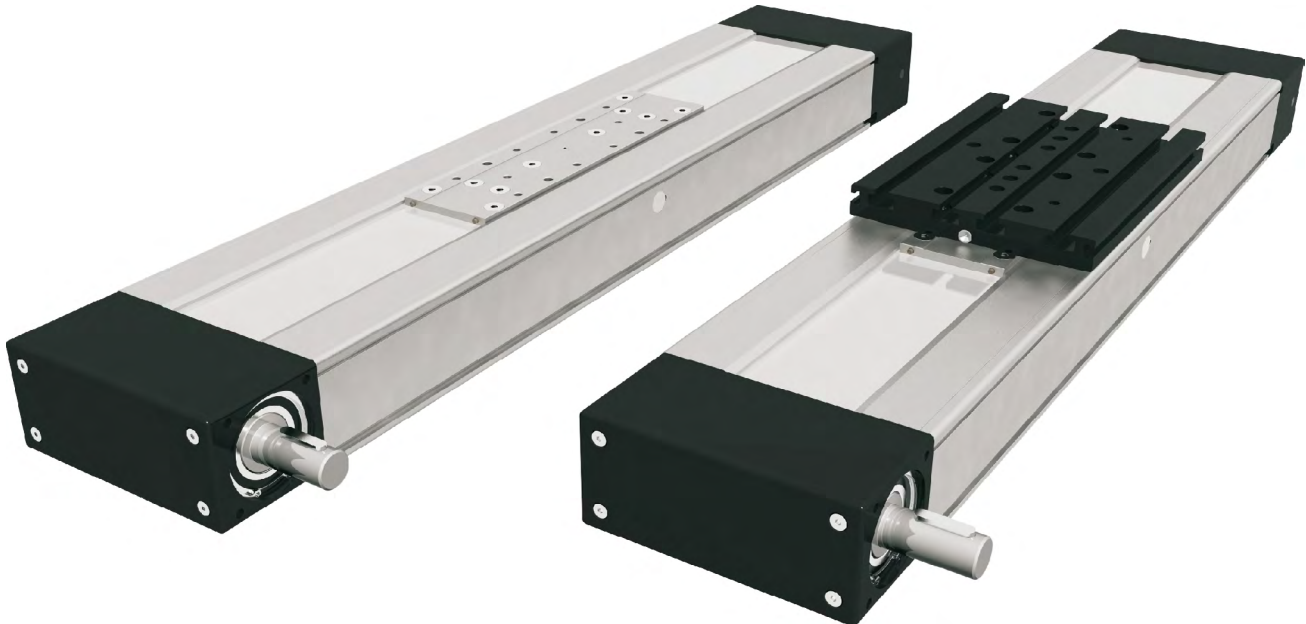

i The aluminium profiles are manufactured according to the medium EN 12020-2 standard

Straightness = 0,35 mm/m; Max. torsion = 0,35 mm/m; Angular torsion = 0,2 mm/40 mm; Parallelism = 0,2 mm

STRUCTURAL DESIGN

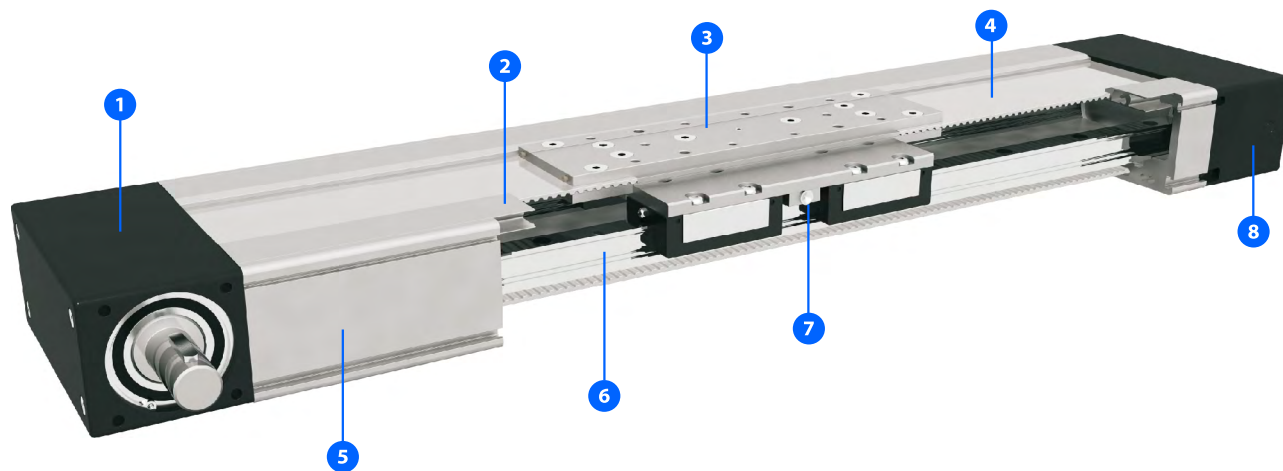

- 1 - Drive block with pulley
- 2 - Aluminum cover
- 3 - Carriage; with built in Magnets
- 4 - AT polyurethane toothed belt with steel tension cords
- 5 - Aluminium profile-Hard anodized
- 6 - Two integrated Linear Ball Guideways
- 7 - Central lubrication port; both sides
- 8 - Tension End with integrated belt tensioning system

HOW TO ORDER



Series : _____
CTJ

Size : _____
90
110
145
200

Absolute stroke [mm] : _____
(Absolute stroke = Effective stroke + 2 x Safety stroke)

Carriage Version : _____
S : Short
L : Long

Number of carriages : _____
The stated number specifies the number of carriages on one Linear unit
(up to 5 carriages available)

Leave blank : For the case of one carriage

Distance between two carriages [mm] : _____
Leave blank : For the case of one carriage

Type of drive pulley : _____
1 : Pulley with journal
10 : Pulley with journal (without Keyway)
2 : Pulley with journal on both sides
20 : Pulley with journal on both sides (without Keyway)
3 : Without drive unit

Drive journal position : _____
L : Journal on left side
R : Journal on right side
Leave blank : For type of drive pulley 2, 20 and 3

! By CTJ 200 with drive pulley 2 or 20, the drive journal position left - **L** or right - **R** side must be also specified - motor/gearbox attachment side.

Connection plate : _____
0: Without
1: With

TECHNICAL DATA

General technical data

Linear Unit	Carriage length Lv [mm]	Dynamic load capacity C [N]	Dynamic moment			Max. permissible loads					Moved mass [kg]	Max. Repeatability [mm]	* Max. length Lmax [mm]	* Max. stroke [mm]	** Min. stroke [mm]	
			Mx [Nm]	My [Nm]	Mz [Nm]	Forces		Moments								
						Fpy [N]	Fpz [N]	Mpx [Nm]	Mpy [Nm]	Mpz [Nm]						
CTJ 90 S	102	4620	125	17	34	2000	4000	110	17	34	0,20	± 0,08	6000	5873	25	
CTJ 90 L	156	9240	250	290	290	3990	8270	200	290	125	0,35	± 0,08				

* For lengths / stroke over the stated value in the table above please contact us.
Values for max. stroke are not valid for multiple carriages
(equation of defining the linear unit length for particular size of the linear unit needs to be used).
** For minimum stroke below the stated value in the table above please contact us.

Operating conditions	
Operating temp.	0°C ~ +60°C
Duty cycle	100%

For operating temperature out of the presented range, please contact us.

i Recommended values of loads

All the data of dynamic moments and load capacities stated in the upper table are theoretical without considering any safety factor. The safety factor depends on the application and its requested safety. We recommend a minimum safety factor (fs =5.0)

Modulus of elasticity

$E = 70000 \text{ N} / \text{mm}^2$

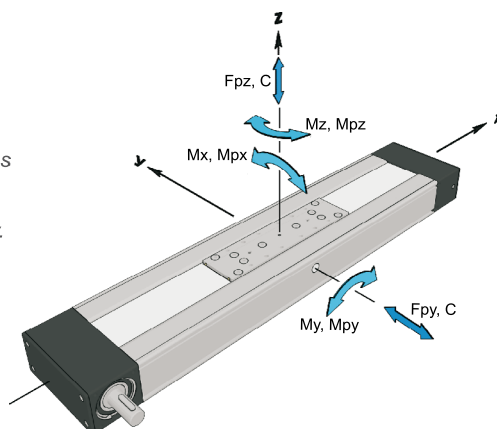

General technical data for double carriage

Linear Unit	Carriage version	Dynamic load capacity C [N]	Dynamic moment			Forces		Max. permissible loads		
			Mx [Nm]	My [Nm]	Mz [Nm]	Fpy [N]	Fpz [N]	Mpx [Nm]	Mpy [Nm]	Mpz [Nm]
CTJ 90	S2	9230	250	4,6 × A	4,6 × A	4000	8000	220	4,0 × A	2,0 × A
	L2	18400	500	9,2 × A	9,2 × A	8000	16500	400	8,3 × A	4,0 × A

* A - Distance between carriages [mm]. More info on following pages.

i Presented values are for informational purposes only. Exact values can be calculated using our sizing selection tool on Unimotion web site.

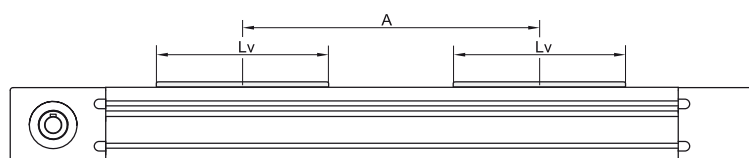

Drive and belt data

Linear Unit	** Max. travel speed [m / s]	Max. drive torque [Nm]	* No load torque [Nm]	Puley drive ratio [mm / rev]	Pulley diameter [mm]	Belt type	Belt width [mm]	Max. force transmitted by belt [N]	Specific spring constant Cspec [N]	** Max. acceleration [m/s ²]
CTJ 90 S	5	7,5	0,40 × nc	90	28,65	AT 3	35	520	402500	70
CTJ 90 L			0,42 × nc							

* The stated values are for strokes (and distances between the carriages A) up to 500mm. No Load Torque value increases with stroke (and with A) elongation.
nc - Number of carriages

** For travel speed and acceleration over the stated value in the table above please contact us.

TECHNICAL DATA

Mass and mass moment of inertia

Linear Unit	Mass of linear unit [kg]	Mass moment of inertia [10 ⁻⁵ kg m ²]	Planar moment of inertia	
			I _y [cm ⁴]	I _z [cm ⁴]
CTJ 90 S	$1,7 + 0,0048 \times (\text{Abs. stroke} + (nc - 1) \times A) + 0,20 \times (nc - 1)$	$7 + 0,0031 \times (\text{Abs. stroke} + (nc - 1) \times A) + 4,1 \times (nc - 1)$	13,4	107,0
CTJ 90 L	$2,1 + 0,0048 \times (\text{Abs. stroke} + (nc - 1) \times A) + 0,35 \times (nc - 1)$	$11 + 0,0031 \times (\text{Abs. stroke} + (nc - 1) \times A) + 7,2 \times (nc - 1)$		

* Absolute stroke [mm]
A - Distance between carriages [mm]. More info on following pages.
nc - Number of carriages

i Mass calculation doesn't include mass of motor, reduction gear, switches and clamps.

Deflection of the linear unit

Fixed - fixed mounting

Fixed - free mounting

δ Maximum deflection of the linear unit [mm]
 δ_{max} Maximum permissible deflection of the linear unit [mm]
 F Applied force [N]
 L_p Unsupported profile length [mm]

i The maximum permissible deflection δ_{max} must not be exceeded. In the case that maximum deflection δ exceeds the maximum permissible deflection δ_{max} additional profile supports are needed.

CTJ 90

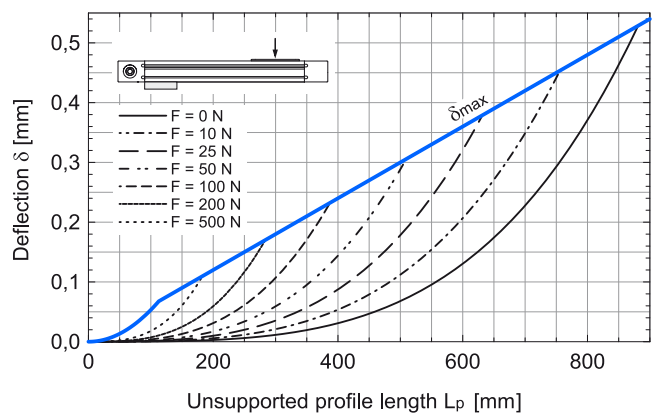
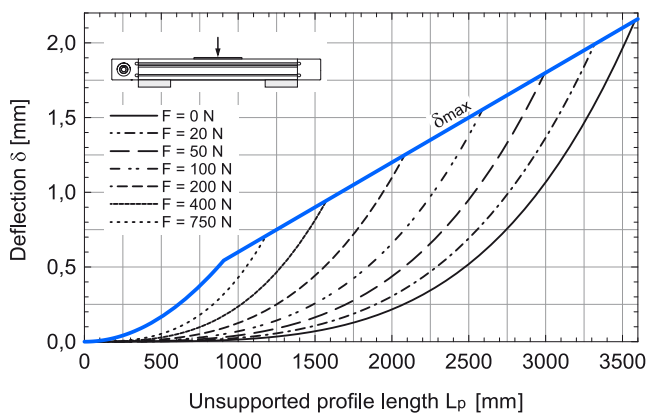

DIMENSIONS

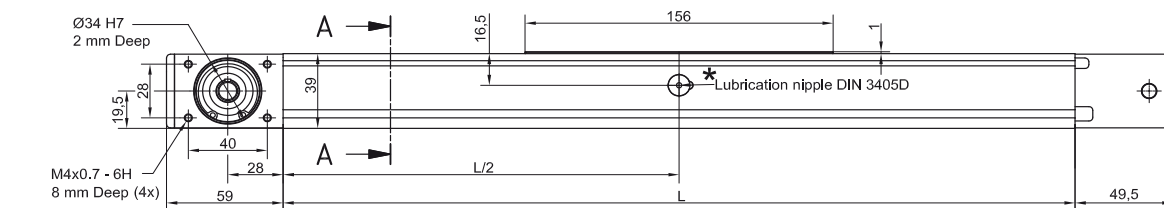

i Linear Unit doesn't include any safety stroke.
Absolute stroke = Effective stroke + 2 x Safety stroke

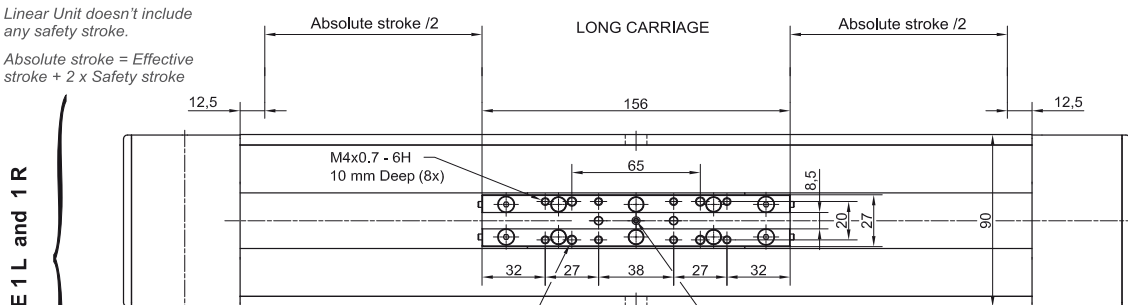

TYPE 1 L and 1 R

* Lubrication port position:
Long carriage: L/2
Short carriage: L/2 - 23,7 mm

i For lubrication port positions in the case of multiple carriages please contact us.

i Journal with or without Keyway.

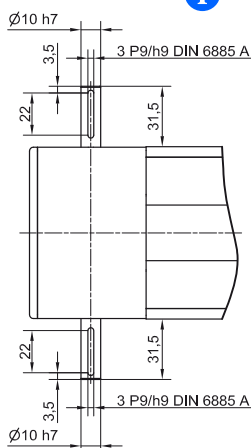

TYPE 2

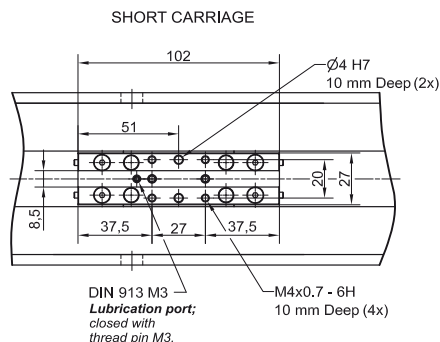

i All dimensions in mm; Drawings scales are not equal.

Defining of the linear unit length

$L = \text{Effective stroke} + 2 \times \text{Safety stroke} + L_v + A \times (n_c - 1) + 25 \text{ mm}$ **i**

$L_{\text{total}} = L + 108,5 \text{ mm}$

n_c - Number of carriages

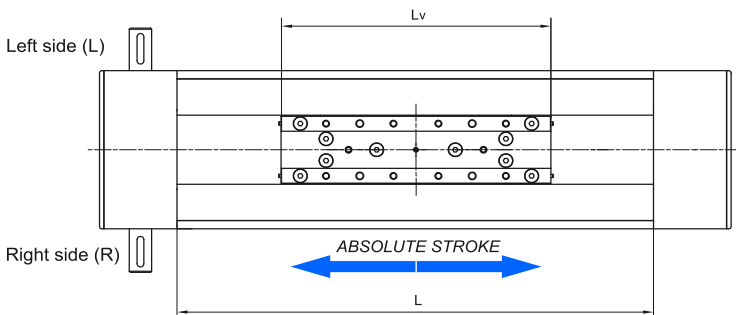

L_v - Long carriage = 156 mm
 L_v - Short carriage = 102 mm

Multiple carriages

i Carriages are connected inside the profile with an aluminium plate (or a toothed belt for the case of longer distances A)

$A \geq L_v$ **i**

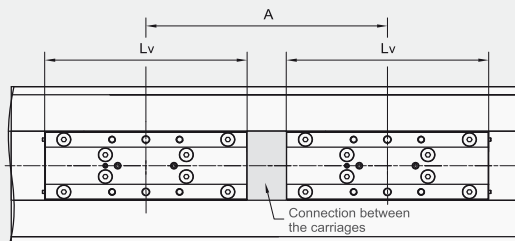

For the case of A [mm] > A_{lim} : **i**

- a toothed belt for the connection of the carriages will be used,

- the following condition must be met:

A [mm] = $A_{\text{lim}} + 3 \times i$,

where $i \in \{1, 2, 3, \dots\}$.

	CTJ 90 S	CTJ 90 L
A_{lim} [mm]	401,5	455,5

DIMENSIONS

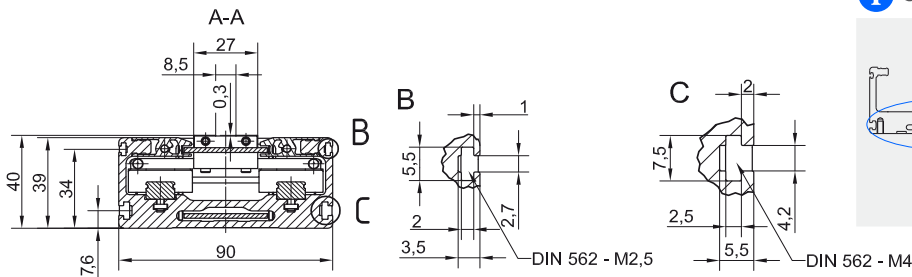

i OPTIONAL: TAP / PIN holes available on request.

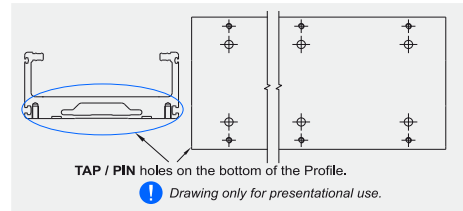

i All dimensions in mm; Drawings scales are not equal.

CONNECTION PLATE

CTJ 90 L

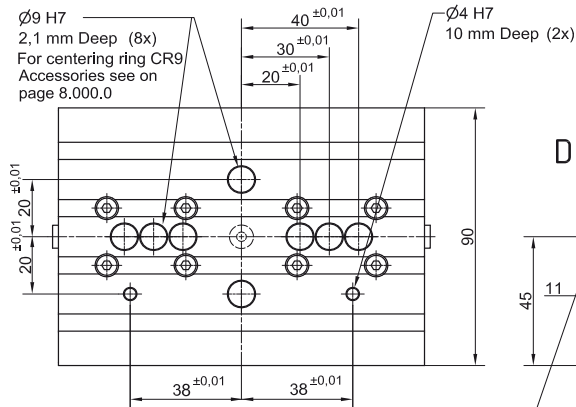
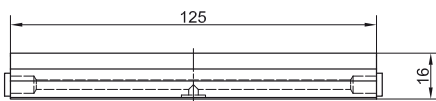

CTJ 90 S

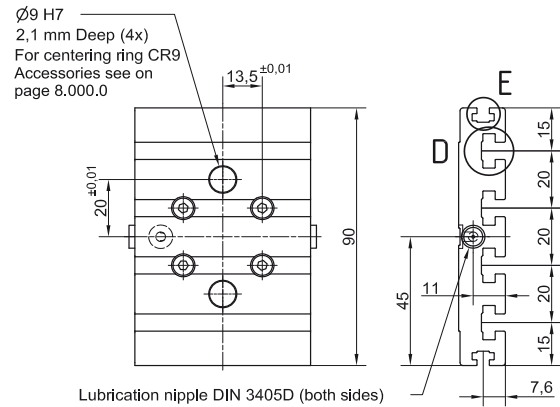
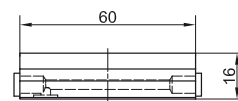

Slot nut
More info at page 8,005.0

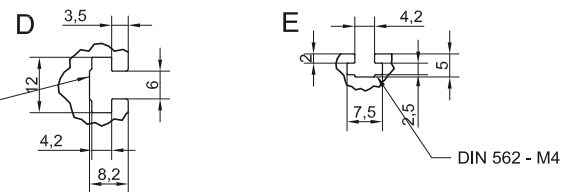

Linear Unit	Plate length [mm]	Weight [kg]	Code
CTJ 90 S	60	0,2	103661
CTJ 90 L	125	0,4	103660

i Mounting elements for mounting the connection plate on the Linear unit are included.

Mounting the drive

- by the **MOTOR ADAPTER WITH COUPLING** (Page 8.020.0)

i Available on request.



TECHNICAL DATA

General technical data

Linear Unit	Carriage length Lv [mm]	Dynamic load capacity C [N]	Dynamic moment			Max. permissible loads						Moved mass [kg]	Max. Repeatability [mm]	* Max. length Lmax [mm]	* Max. stroke [mm]	** Min. stroke [mm]	
			Mx [Nm]	My [Nm]	Mz [Nm]	Forces		Moments									
						Fpy [N]	Fpz [N]	Mpx [Nm]	Mpy [Nm]	Mpz [Nm]							
CTJ 110 S	170	19800	610	118	235	6470	8390	260	90	90	0,64	± 0,08	6000	5805	40		
CTJ 110 L	215	39600	1225	1680	1680	13080	18820	525	880	550	0,98	± 0,08					

*For lengths / stroke over the stated value in the table above please contact us.
Values for max. stroke are not valid for multiple carriages
(equation of defining the linear unit length for particular size of the linear unit needs to be used).
**For minimum stroke below the stated value in the table above please contact us.

Operating conditions	
Operating temp.	0°C ~ +60°C
Duty cycle	100%

For operating temperature out of the presented range, please contact us.

i Recommended values of loads

All the data of dynamic moments and load capacities stated in the upper table are theoretical without considering any safety factor. The safety factor depends on the application and its requested safety. We recommend a minimum safety factor (fs =5.0)

Modulus of elasticity

$E = 70000 \text{ N / mm}^2$

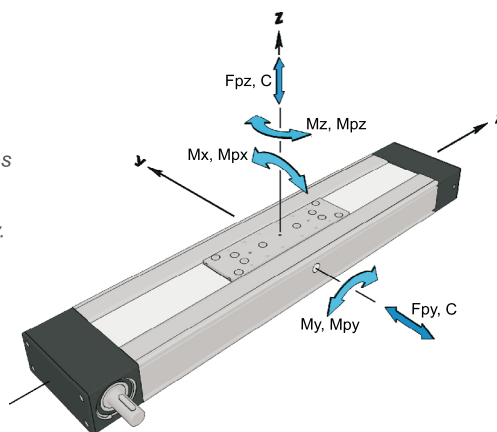

General technical data for double carriage

Linear Unit	Carriage version	Dynamic load capacity C [N]	Dynamic moment			Forces		Max. permissible loads		
			Mx [Nm]	My [Nm]	Mz [Nm]	Fpy [N]	Fpz [N]	Mpx [Nm]	Mpy [Nm]	Mpz [Nm]
CTJ 110	S2	39600	1220	19,8 × A	19,8 × A	12940	16770	520	8,4 × A	6,5 × A
	L2	79200	2450	39,6 × A	39,6 × A	26150	37600	1050	18,8 × A	13,1 × A

*A - Distance between carriages [mm]. More info on following pages.

i Presented values are for informational purposes only. Exact values can be calculated using our sizing selection tool on Unimotion web site.

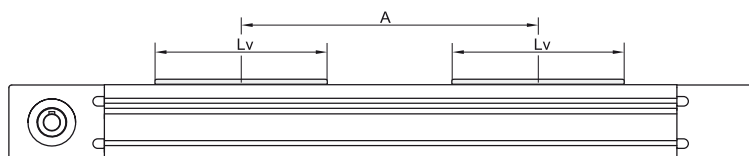

Drive and belt data

Linear Unit	** Max. travel speed [m / s]	Max. drive torque [Nm]	* No load torque [Nm]	Puley drive ratio [mm / rev]	Pulley diameter [mm]	Belt type	Belt width [mm]	Max. force transmitted by belt [N]	Specific spring constant Cspec [N]	** Max. acceleration [m/s ²]
CTJ 110 S	6	15,7	0,98 × nc	120	38,20	AT 5	50	820	960000	70
CTJ 110 L			1,00 × nc							

*The stated values are for strokes (and distances between the carriages A) up to 500mm. No Load Torque value increases with stroke (and with A) elongation.
nc - Number of carriages

**For travel speed and acceleration over the stated value in the table above please contact us.

TECHNICAL DATA

Mass and mass moment of inertia

Linear Unit	Mass of linear unit [kg]	Mass moment of inertia [10 ⁻⁵ kg m ²]	Planar moment of inertia	
			I _y [cm ⁴]	I _z [cm ⁴]
CTJ 110 S	$3,6 + 0,0072 \times (\text{Abs. stroke} + (nc - 1) \times A) + 0,64 \times (nc - 1)$	$36 + 0,0125 \times (\text{Abs. stroke} + (nc - 1) \times A) + 23,3 \times (nc - 1)$	31,1	217,2
CTJ 110 L	$4,2 + 0,0072 \times (\text{Abs. stroke} + (nc - 1) \times A) + 0,98 \times (nc - 1)$	$49 + 0,0125 \times (\text{Abs. stroke} + (nc - 1) \times A) + 35,8 \times (nc - 1)$		

*Absolute stroke [mm]
A - Distance between carriages [mm]. More info on following pages.
nc - Number of carriages

i Mass calculation doesn't include mass of motor, reduction gear, switches and clamps.

Deflection of the linear unit

Fixed - fixed mounting

Fixed - free mounting

δ Maximum deflection of the linear unit [mm]
 δ_{max} Maximum permissible deflection of the linear unit [mm]
 F Applied force [N]
 L_p Unsupported profile length [mm]

i The maximum permissible deflection δ_{max} must not be exceeded. In the case that maximum deflection δ exceeds the maximum permissible deflection δ_{max} additional profile supports are needed.

CTJ 110

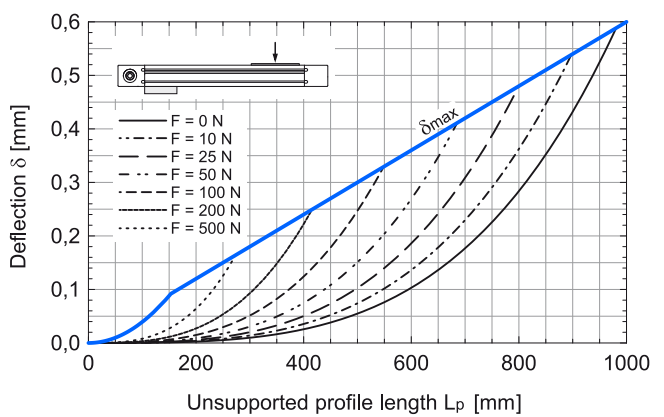
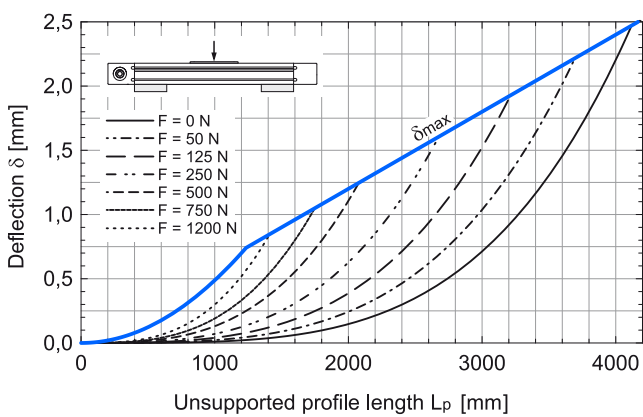

DIMENSIONS

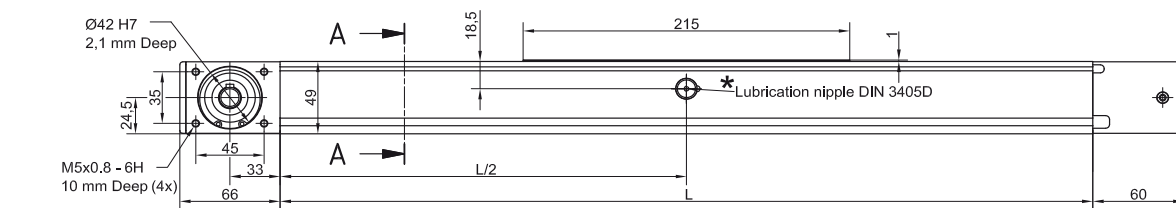

i Linear Unit doesn't include any safety stroke.

Absolute stroke = Effective stroke + 2 x Safety stroke

TYPE 1 L and 1 R

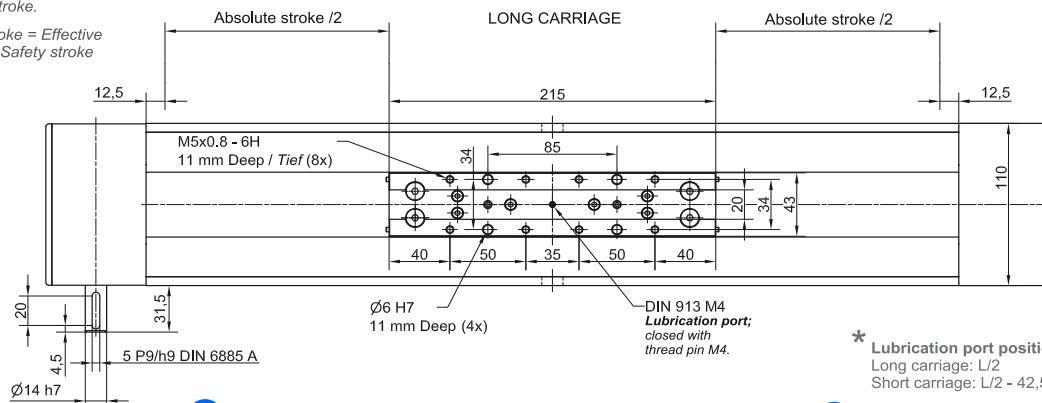

i Journal with or without Keyway.

* Lubrication port position:
Long carriage: L/2
Short carriage: L/2 - 42,5 mm

i For lubrication port positions in the case of multiple carriages please contact us.

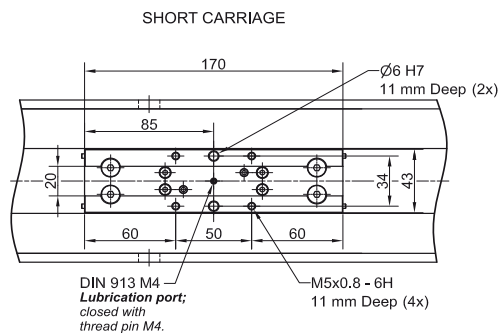
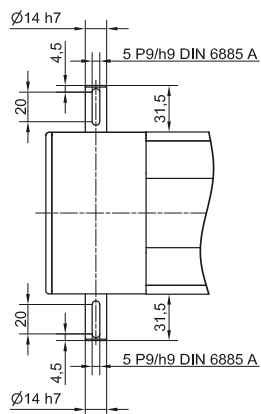

i All dimensions in mm; Drawings scales are not equal.

Defining of the linear unit length

$L = \text{Effective stroke} + 2 \times \text{Safety stroke} + L_v + A \times (n_c - 1) + 25 \text{ mm}$ **i**

$L_{\text{total}} = L + 126 \text{ mm}$ n_c - Number of carriages

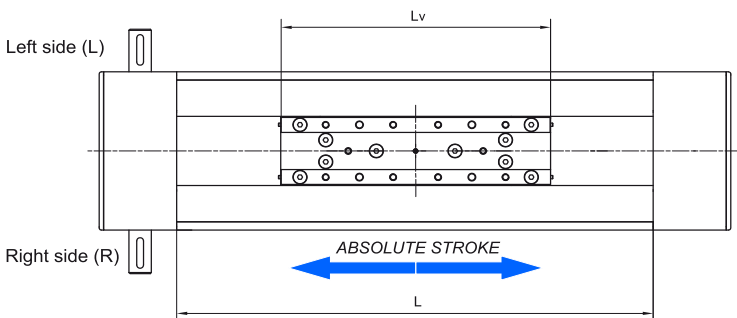

L_v - Long carriage = 215 mm
 L_v - Short carriage = 170 mm

Multiple carriages

i Carriages are connected inside the profile with an aluminium plate (or a toothed belt for the case of longer distances A)

$A \geq L_v$ **i**

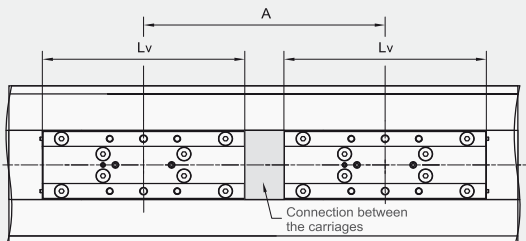

For the case of A [mm] > A_{lim} : **i**

- a toothed belt for the connection of the carriages will be used,

- the following condition must be met:

A [mm] = $A_{lim} + 5 \times i$,
where $i \in \{1, 2, 3, \dots\}$.

	CTJ 110 S	CTJ 110 L
A_{lim} [mm]	601	646

DIMENSIONS

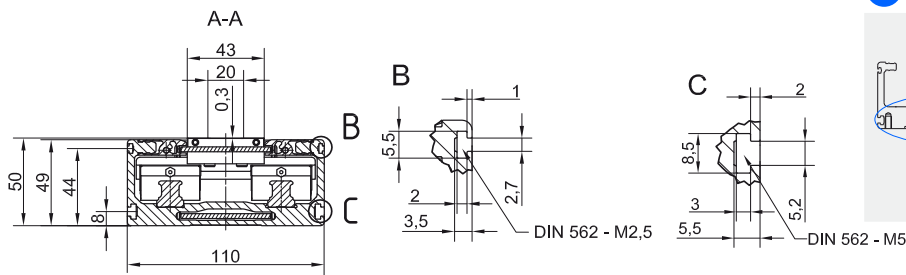

i OPTIONAL: TAP / PIN holes available on request.

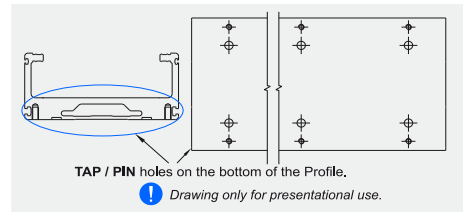

i All dimensions in mm; Drawings scales are not equal.

CONNECTION PLATE

CTJ 110 L

CTJ 110 S

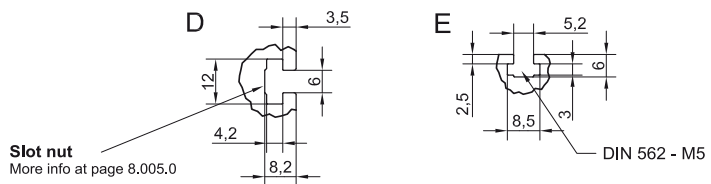
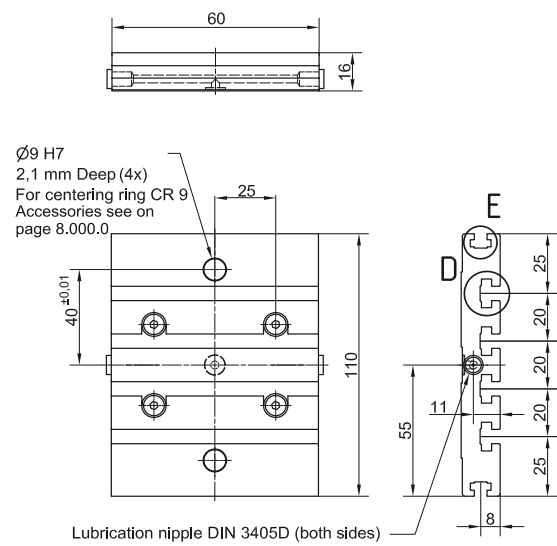
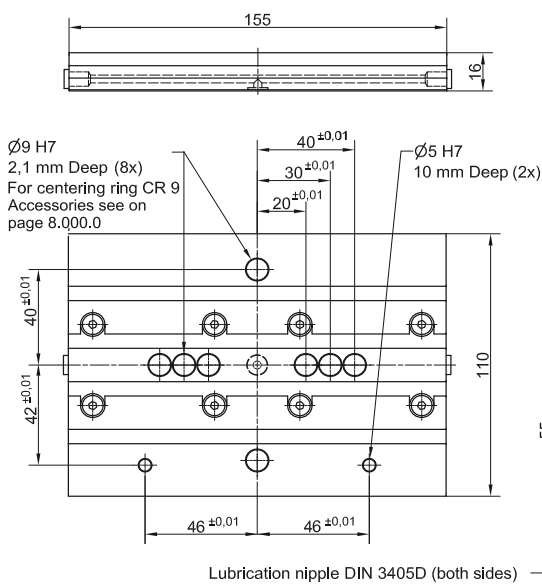

Slot nut
More info at page 8.005.0

Linear Unit	Plate length [mm]	Weight [kg]	Code
CTJ 110 S	60	0,35	103663
CTJ 110 L	155	0,60	103662

i Mounting elements for mounting the connection plate on the Linear unit are included.

Mounting the drive

- by the **MOTOR ADAPTER WITH COUPLING** (Page 8.020.0)

i Available on request.



TECHNICAL DATA

General technical data

Linear Unit	Carriage length Lv [mm]	Dynamic load capacity C [N]	Dynamic moment			Max. permissible loads					Moved mass [kg]	Max. Repeatability [mm]	* Max. length Lmax [mm]	* Max. stroke [mm]	** Min. stroke [mm]	
			Mx [Nm]	My [Nm]	Mz [Nm]	Forces		Moments								
			Mx [Nm]	My [Nm]	Mz [Nm]	Fpy [N]	Fpz [N]	Mpx [Nm]	Mpy [Nm]	Mpz [Nm]						
CTJ 145 S	180	34200	1500	260	520	8930	15320	674	260	180	1,35	± 0,08	6000	5795	55	
CTJ 145 L	240	68400	3005	3420	3420	17870	30640	1200	1700	893	2,25	± 0,08		5735	55	

* For lengths / stroke over the stated value in the table above please contact us.
Values for max. stroke are not valid for multiple carriages
(equation of defining the linear unit length for particular size of the linear unit needs to be used).

** For minimum stroke below the stated value in the table above please contact us.

Operating conditions	
Operating temp.	0°C ~ +60°C
Duty cycle	100%

For operating temperature out of the presented range, please contact us.

i Recommended values of loads

All the data of dynamic moments and load capacities stated in the upper table are theoretical without considering any safety factor. The safety factor depends on the application and its requested safety. We recommend a minimum safety factor (fs = 5.0)

Modulus of elasticity

$E = 70000 \text{ N} / \text{mm}^2$

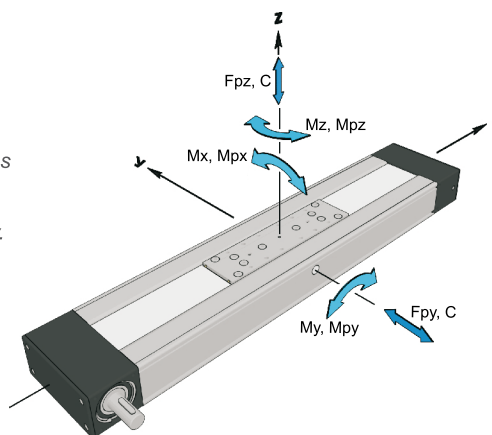

General technical data for double carriage

Linear Unit	Carriage version	Dynamic load capacity C [N]	Dynamic moment			Max. permissible loads				
			* Mx [Nm]	My [Nm]	Mz [Nm]	Forces		Moments		
			Mx [Nm]	My [Nm]	Mz [Nm]	Fpy [N]	Fpz [N]	Mpx [Nm]	Mpy [Nm]	Mpz [Nm]
CTJ 145	S2	68400	3000	34,2 × A	34,2 × A	17870	30640	1350	15,3 × A	8,9 × A
	L2	136800	6000	68,4 × A	68,4 × A	35700	61200	2400	30,6 × A	17,8 × A

* A - Distance between carriages [mm]. More info on following pages.

i Presented values are for informational purposes only. Exact values can be calculated using our sizing selection tool on Unimotion web site.

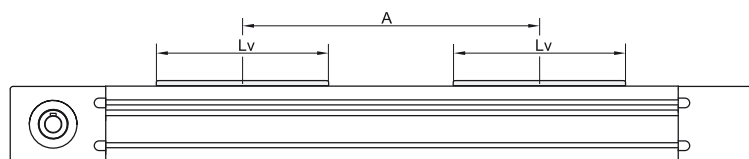

Drive and belt data

Linear Unit	** Max. travel speed [m / s]	Max. drive torque [Nm]	* No load torque [Nm]	Pulley drive ratio [mm / rev]	Pulley diameter [mm]	Belt type	Belt width [mm]	Max. force transmitted by belt [N]	Specific spring constant Cspec [N]	** Max. acceleration [m/s ²]
CTJ 145 S	6	33,6	1,48 × nc	165	52,52	AT 5	70	1280	1360000	70
CTJ 145 L			1,50 × nc							

* The stated values are for strokes (and distances between the carriages A) up to 500mm. No Load Torque value increases with stroke (and with A) elongation.

nc - Number of carriages

** For travel speed and acceleration over the stated value in the table above please contact us.

TECHNICAL DATA

Mass and mass moment of inertia

Linear Unit	Mass of linear unit [kg]	Mass moment of inertia [10 ⁻⁵ kg m ²]	Planar moment of inertia	
			I _y [cm ⁴]	I _z [cm ⁴]
CTJ 145 S	$7,2 + 0,0127 \times (\text{Abs. stroke} + (nc - 1) \times A) + 1,35 \times (nc - 1)$	$145 + 0,0330 \times (\text{Abs. stroke} + (nc - 1) \times A) + 93,1 \times (nc - 1)$	78,9	707,6
CTJ 145 L	$8,8 + 0,0127 \times (\text{Abs. stroke} + (nc - 1) \times A) + 2,25 \times (nc - 1)$	$208 + 0,0330 \times (\text{Abs. stroke} + (nc - 1) \times A) + 155,2 \times (nc - 1)$		

* Absolute stroke [mm]

A - Distance between carriages [mm]. More info on following pages.
nc - Number of carriages

i Mass calculation doesn't include mass of motor, reduction gear, switches and clamps.

Deflection of the linear unit

Fixed - fixed mounting

Fixed - free mounting

δ Maximum deflection of the linear unit [mm]
 δ_{max} Maximum permissible deflection of the linear unit [mm]
 F Applied force [N]
 L_p Unsupported profile length [mm]

i The maximum permissible deflection δ_{max} must not be exceeded. In the case that maximum deflection δ exceeds the maximum permissible deflection δ_{max} additional profile supports are needed.

CTJ 145

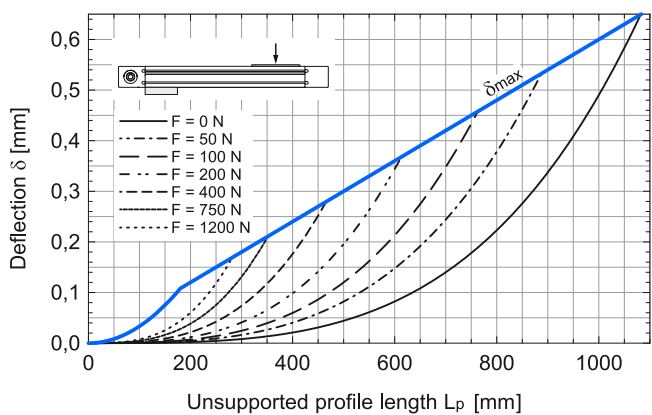
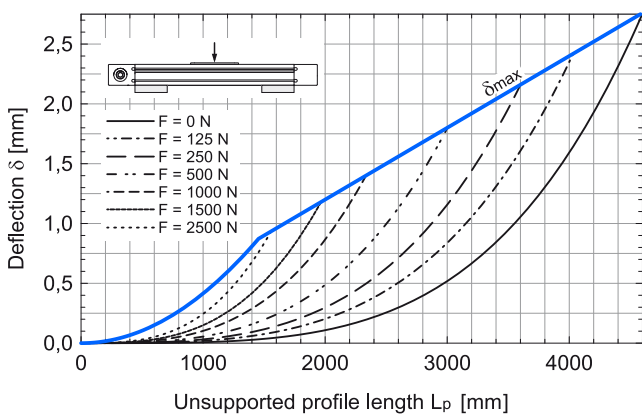

DIMENSIONS

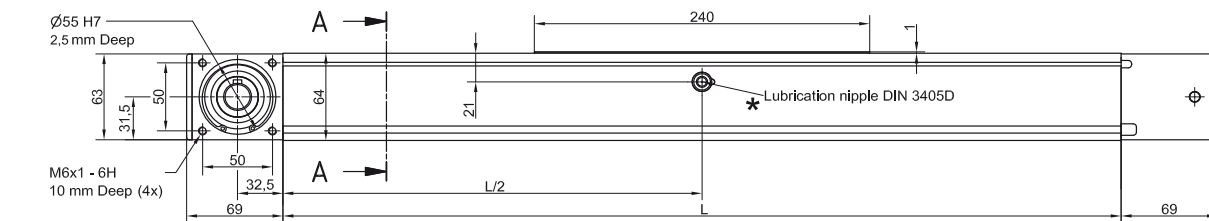

i Linear Unit doesn't include any safety stroke.
Absolute stroke = Effective stroke + 2 x Safety stroke

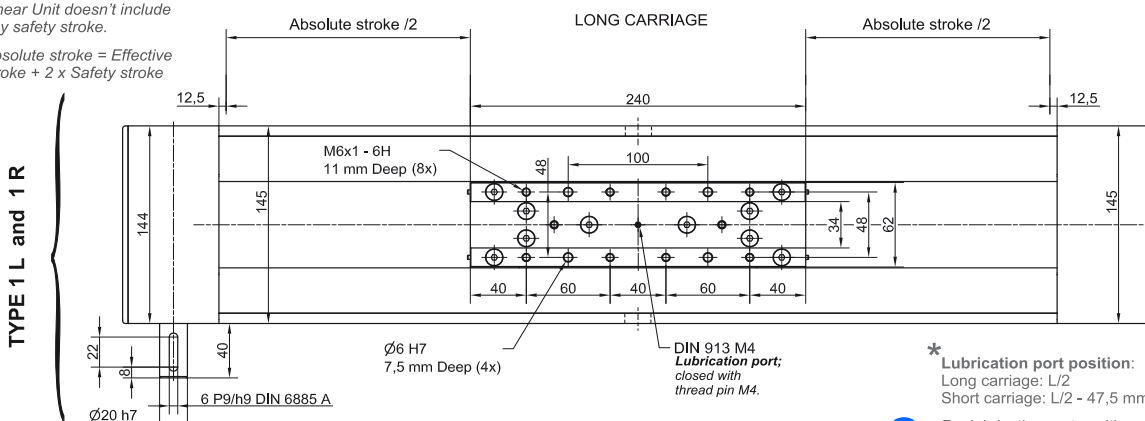

* Lubrication port position:
Long carriage: L/2
Short carriage: L/2 - 47,5 mm

i For lubrication port positions in the case of multiple carriages please contact us.

i Journal with or without Keyway.

TYPE 1 L and 1 R

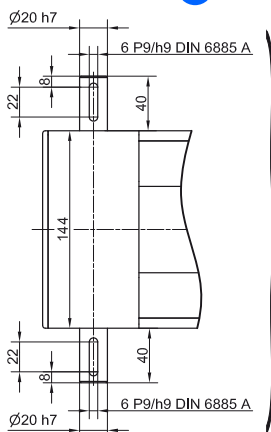

TYPE 2

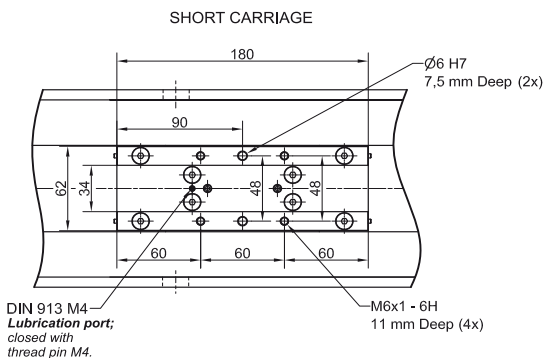

i All dimensions in mm; Drawings scales are not equal.

Defining of the linear unit length

$L = \text{Effective stroke} + 2 \times \text{Safety stroke} + L_v + A \times (n_c - 1) + 25 \text{ mm}$ **i**

$L_{\text{total}} = L + 138 \text{ mm}$ n_c - Number of carriages

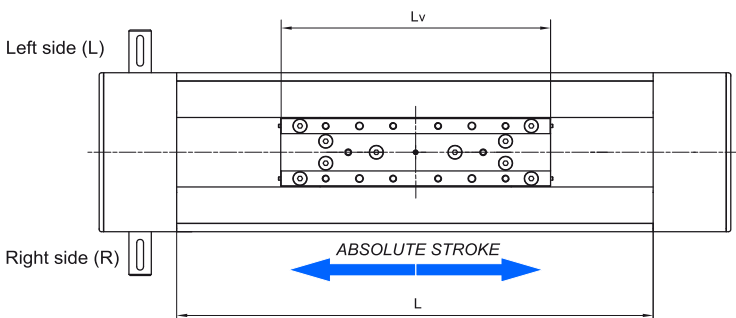

L_v - Long carriage = 240 mm
 L_v - Short carriage = 180 mm

Multiple carriages

i Carriages are connected inside the profile with an aluminium plate (or a toothed belt for the case of longer distances A)

$A \geq L_v$ **i**

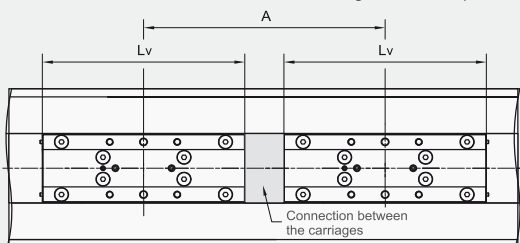

For the case of A [mm] > A_{lim} : **i**

- a toothed belt for the connection of the carriages will be used,

- the following condition must be met:

A [mm] = $A_{lim} + 5 \times i$,
where $i \in \{1, 2, 3, \dots\}$.

	CTJ 145 S	CTJ 145 L
A_{lim} [mm]	801	861

DIMENSIONS

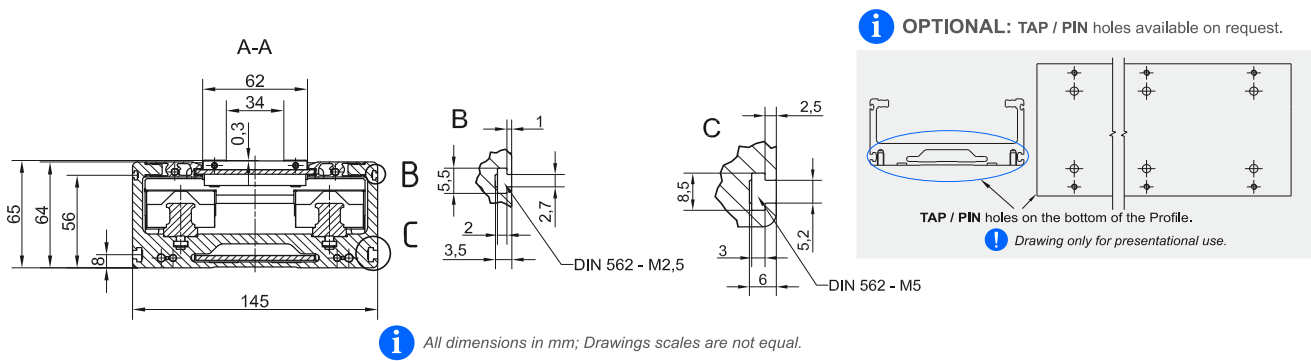

CONNECTION PLATE

CTJ 145 L

CTJ 145 S

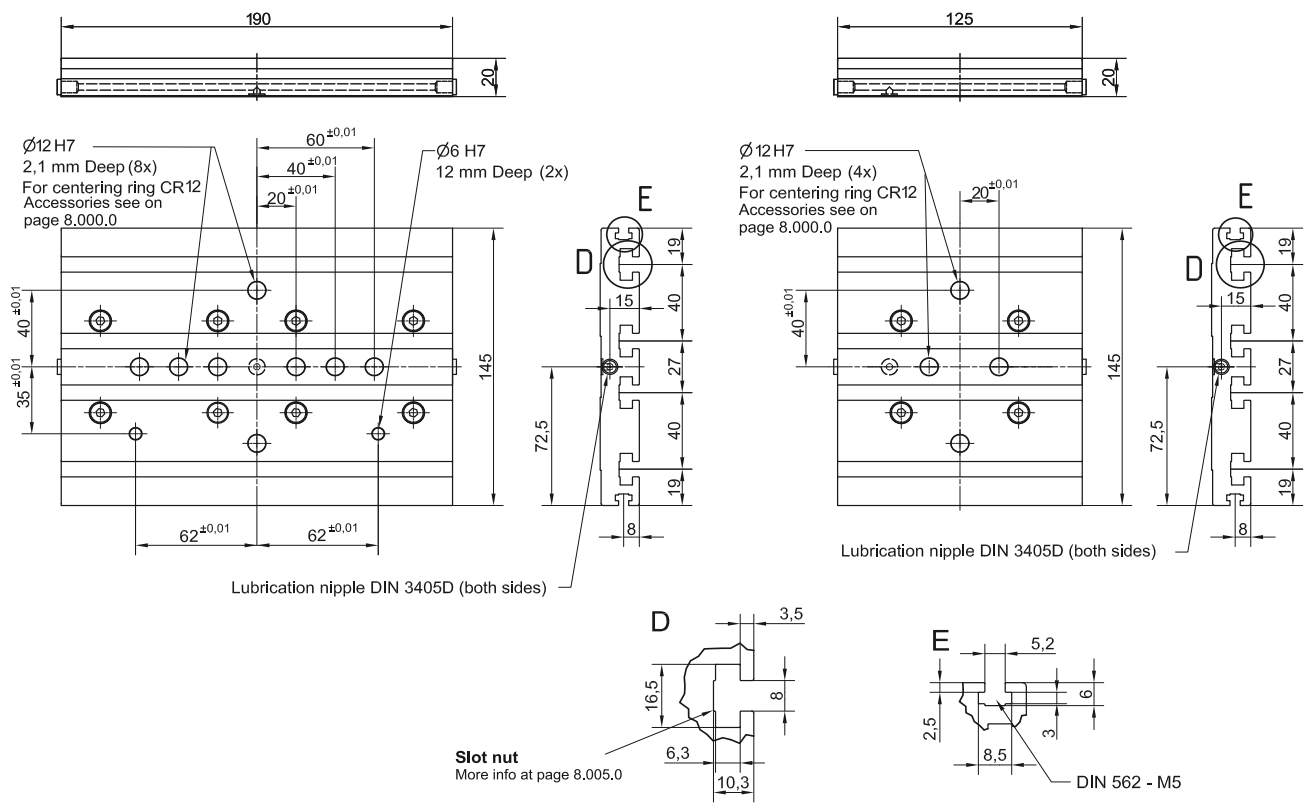

Linear Unit	Plate length [mm]	Weight [kg]	Code
CTJ 145 S	125	0,8	103665
CTJ 145 L	190	1,3	103664

i Mounting elements for mounting the connection plate on the Linear unit are included.

Mounting the drive

- by the **MOTOR ADAPTER WITH COUPLING** (Page 8.020.0)

i Available on request.



TECHNICAL DATA

General technical data

Linear Unit	Carriage length Lv [mm]	Dynamic load capacity C [N]	Dynamic moment			Max. permissible loads					Moved mass [kg]	Max. Repeatability [mm]	* Max. length Lmax [mm]	* Max. stroke [mm]	** Min. stroke [mm]	
			Mx [Nm]	My [Nm]	Mz [Nm]	Forces		Moments								
						Fpy [N]	Fpz [N]	Mpx [Nm]	Mpy [Nm]	Mpz [Nm]						
CTJ 200 S	265	49600	3235	450	900	10000	24520	1600	450	308	3,05	± 0,08	6000	5710	65	
CTJ 200 L	405	99200	6470	8680	8680	20000	50900	3250	4550	1750	5,70	± 0,08				5570

* For lengths / stroke over the stated value in the table above please contact us.
Values for max. stroke are not valid for multiple carriages
(equation of defining the linear unit length for particular size of the linear unit needs to be used).

** For minimum stroke below the stated value in the table above please contact us.

Operating conditions	
Operating temp.	0°C ~ +60°C
Duty cycle	100%

For operating temperature out of the presented range, please contact us.

i Recommended values of loads

All the data of dynamic moments and load capacities stated in the upper table are theoretical without considering any safety factor. The safety factor depends on the application and its requested safety. We recommend a minimum safety factor ($f_s = 5.0$)

Modulus of elasticity

$$E = 70000 \text{ N} / \text{mm}^2$$

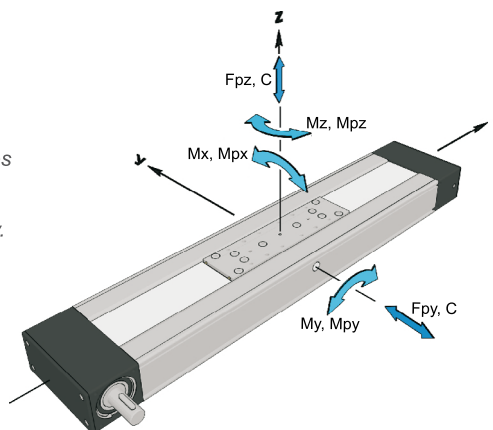

General technical data for double carriage

Linear Unit	Carriage version	Dynamic load capacity C [N]	Dynamic moment			Forces		Max. permissible loads		
			Mx [Nm]	My [Nm]	Mz [Nm]	Fpy [N]	Fpz [N]	Mpx [Nm]	Mpy [Nm]	Mpz [Nm]
CTJ 200	S2	99200	6470	49,6 × A	49,6 × A	20000	49040	3200	24,5 × A	10,0 × A
	L2	198400	12940	99,2 × A	99,2 × A	40000	101800	6500	50,9 × A	20,0 × A

* A - Distance between carriages [mm]. More info on following pages.

i Presented values are for informational purposes only. Exact values can be calculated using our sizing selection tool on Unimotion web site.

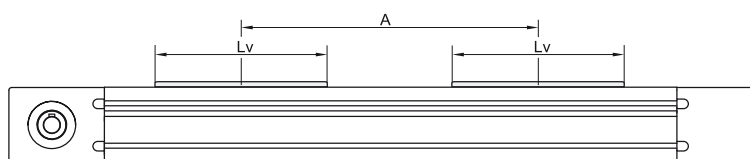

Drive and belt data

Linear Unit	** Max. travel speed [m / s]	Max. drive torque [Nm]	* No load torque [Nm]	Puley drive ratio [mm / rev]	Puley diameter [mm]	Belt type	Belt width [mm]	Max. force transmitted by belt [N]	Specific spring constant Cspec [N]	** Max. acceleration [m/s ²]
CTJ 200 S	6	102 with keyway	3,5 × nc	250	79,58	AT 10	100	2850	4350000	70
CTJ 200 L		113 without keyway	4,5 × nc							

* The stated values are for strokes (and distances between the carriages A) up to 500mm. No Load Torque value increases with stroke (and with A) elongation.
nc - Number of carriages

** For travel speed and acceleration over the stated value in the table above please contact us.

TECHNICAL DATA

Mass and mass moment of inertia

Linear Unit	Mass of linear unit	Mass moment of inertia	Planar moment of inertia	
	[kg]	[10 ⁻⁵ kg m ²]	I _y [cm ⁴]	I _z [cm ⁴]
CTJ 200 S	$20,2 + 0,0245 \times (\text{Abs. stroke} + (\text{nc} - 1) \times A) + 3,1 \times (\text{nc} - 1)$	$778 + 0,1868 \times (\text{Abs. stroke} + (\text{nc} - 1) \times A) + 482,9 \times (\text{nc} - 1)$	376,4	2744,6
CTJ 200 L	$26,2 + 0,0245 \times (\text{Abs. stroke} + (\text{nc} - 1) \times A) + 5,7 \times (\text{nc} - 1)$	$1210 + 0,1868 \times (\text{Abs. stroke} + (\text{nc} - 1) \times A) + 902,4 \times (\text{nc} - 1)$		

* Absolute stroke [mm]

A - Distance between carriages [mm]. More info on following pages.

nc - Number of carriages

i Mass calculation doesn't include mass of motor, reduction gear, switches and clamps.

Deflection of the linear unit

Fixed - fixed mounting

Fixed - free mounting

δ Maximum deflection of the linear unit [mm]
 δ_{max} Maximum permissible deflection of the linear unit [mm]
 F Applied force [N]
 L_p Unsupported profile length [mm]

i The maximum permissible deflection δ_{max} must not be exceeded. In the case that maximum deflection δ exceeds the maximum permissible deflection δ_{max} additional profile supports are needed.

CTJ 200

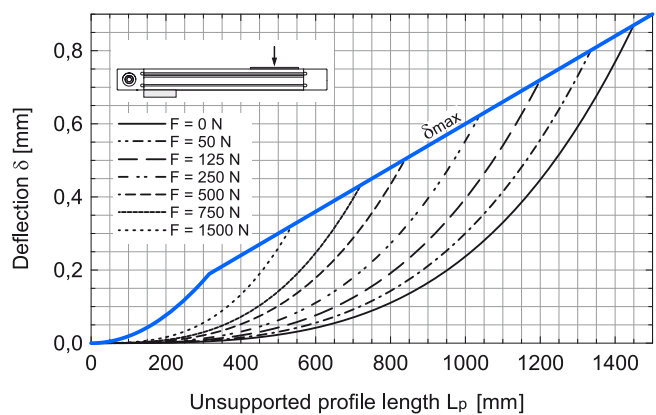
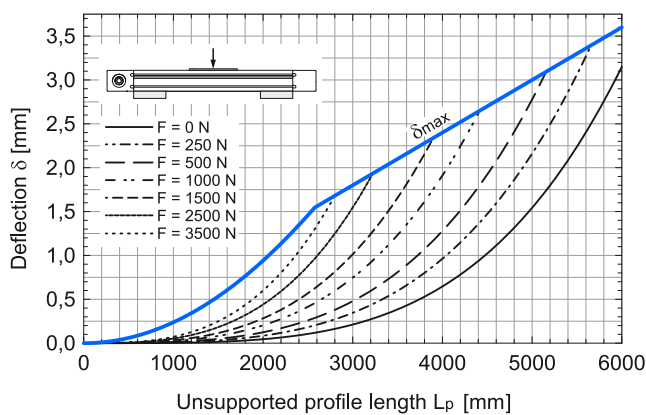

DIMENSIONS

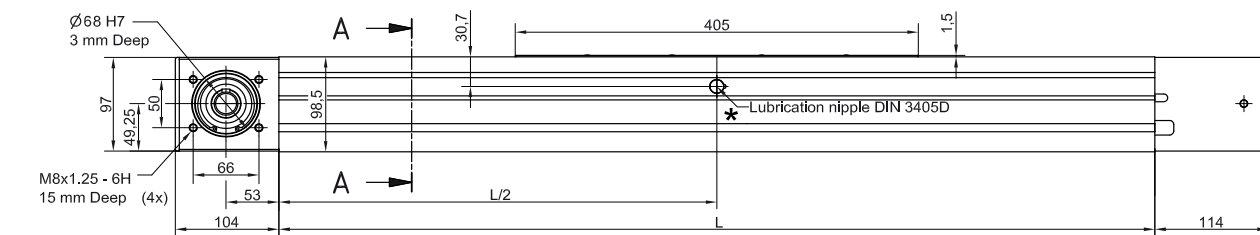

i Linear Unit doesn't include any safety stroke.
Absolute stroke = Effective stroke + 2 x Safety stroke

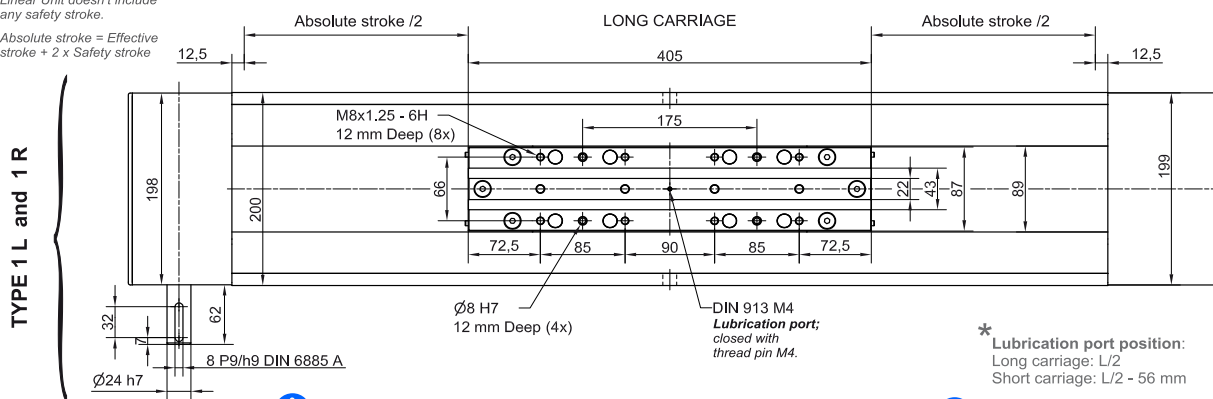

* Lubrication port position:
Long carriage: L/2
Short carriage: L/2 - 56 mm

i For lubrication port positions in the case of multiple carriages please contact us.

i Journal with or without Keyway.

TYPE 1 L and 1 R

TYPE 2

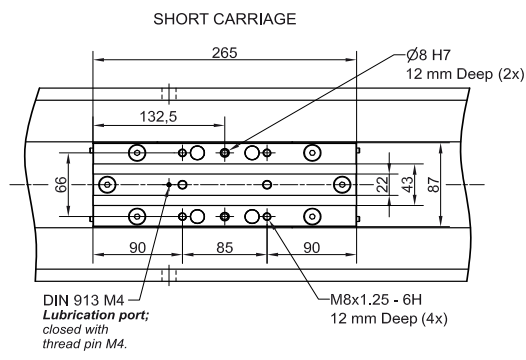
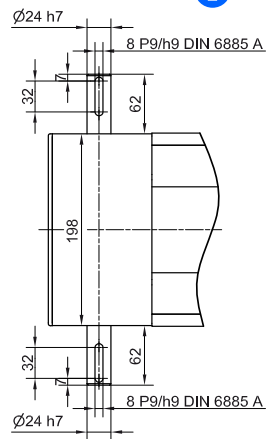

i All dimensions in mm; Drawings scales are not equal.

Defining of the linear unit length

L = Effective stroke + 2 x Safety stroke + Lv + A x (nc - 1) + 25 mm

Ltotal = L + 218 mm *nc - Number of carriages*

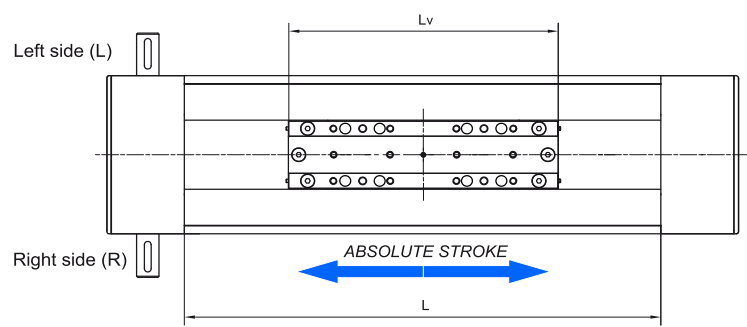

Lv - Long carriage = 405 mm
Lv - Short carriage = 265 mm

Multiple carriages

i Carriages are connected inside the profile with an aluminium plate (or a toothed belt for the case of longer distances A)

A ≥ Lv

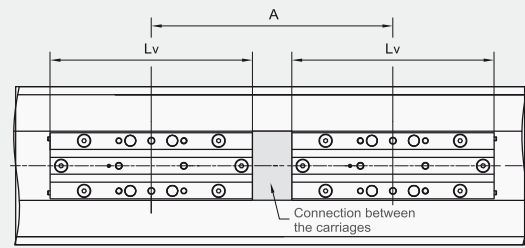

For the case of A [mm] > A_{lim} :

- a toothed belt for the connection of the carriages will be used,
- the following condition must be met:
 $A [mm] = A_{lim} + 10 \times i$,
where $i \in \{1,2,3,\dots\}$.

	CTJ 200 S	CTJ 200 L
A _{lim} [mm]	1006	1146

DIMENSIONS

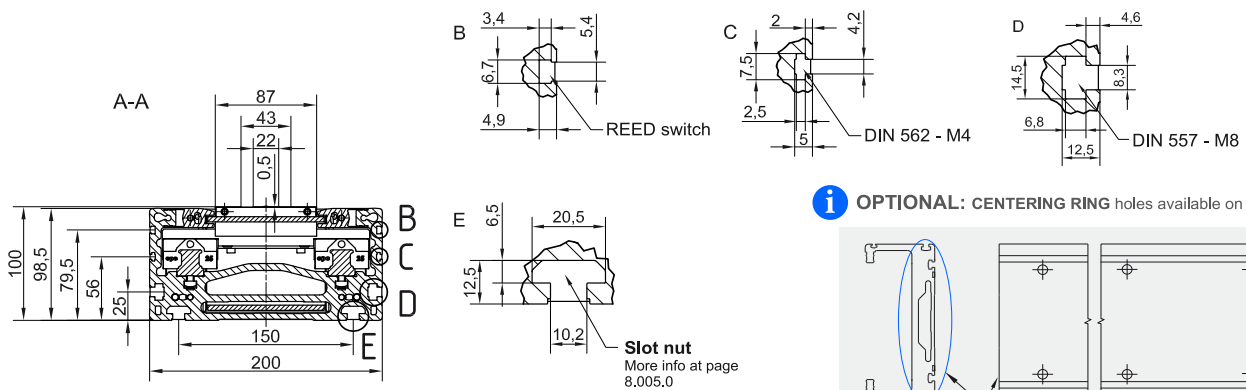

i All dimensions in mm; Drawings scales are not equal.

i OPTIONAL: CENTERING RING holes available on request.

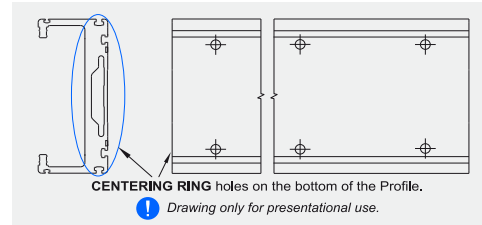

CONNECTION PLATE

CTJ 200 L

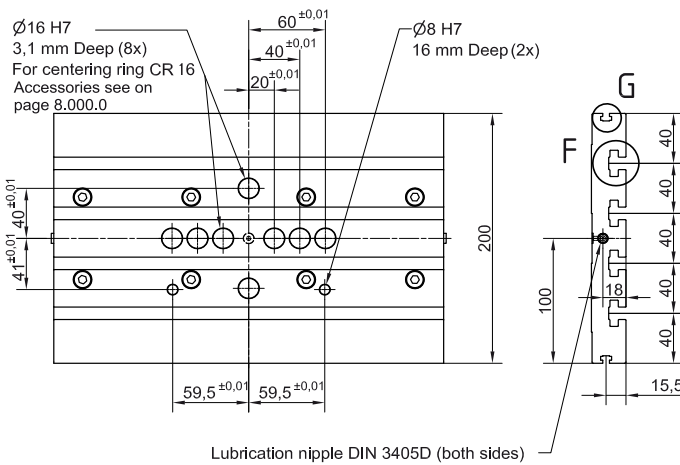
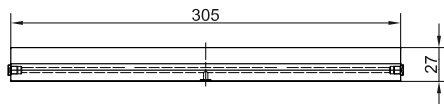

CTJ 200 S

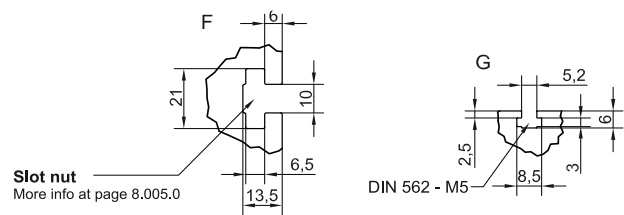
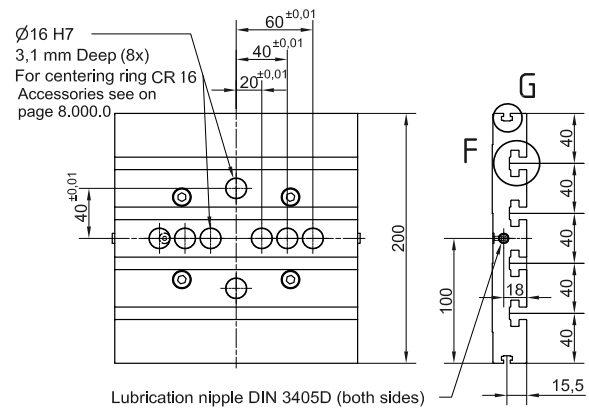
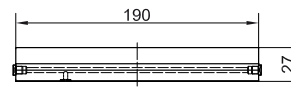

Linear Unit	Plate length [mm]	Weight [kg]	Code
CTJ 200 S	190	2,3	103667
CTJ 200 L	305	3,7	103666

i Mounting elements for mounting the connection plate on the Linear unit are included.

Mounting the drive

- by the **MOTOR ADAPTER WITH COUPLING** (Page 8.020.0)

i Available on request.

