



# E FAMILY



# QUICK INDEX

Basic Features ..... Page 3  
 Valve Types — Series ..... See Chart Below



	Page 8-10	Page 11-13	Page 14-17	Page 18-21	Page 22	Page 23
Series	<b>EZ</b>	<b>E5</b>	<b>E4</b>	<b>E</b>	<b>E3</b>	<b>E* QE</b>
Description	Compact Direct Acting	Compact Direct Acting	Compact Direct Acting	Medium Flow Direct Acting	High Flow Direct Lift	High Flow
Pressure Range	vacuum to 250 psi (17 bar)	vacuum to 500 psi (34 bar)	vacuum to 500 psi (34 bar)	vacuum to 500 psi (34 bar)	0-150 psi (10.3 bar)	5-150 psi (0.3-10.3 bar)
Flow Range	.06 to 75	.022 to 25	.022 to 25	0.026 to 0.11	0.11 to 0.16	0.06- 0.11 Inlet 3.3-8.8 Exhaust
Port Size NPT	1/8" NPT	1/8" - 1/4" NPT	1/8" - 1/4" NPT	1/8" - 1/4" NPT	1/4" NPT	1/4"-1/2" NPT Inlet 3/8"-3/4" NPT Exhaust
Nominal Power	10 AC watt 10.5 DC watt	6 - 8.5 AC watt 7-10 DC watt	0.85 - 1.8 watt	6 - 8.5 AC watt 7-10 DC watt	0.85 - 1.8 watt	0.85 - 7.2 Watt
Seals	NBR-Nitrile (Buna N) FKM (fluorocarbon) Optional		FKM (fluorocarbon)	NBR-Nitrile (Buna N)	FKM (fluorocarbon)	

### Materials, General Purpose

Side Port	Aluminum	Page 10	—	—	—	—	—
	Stainless Steel	—	Page 11	—	Page 18	—	Page 23
Manifold Mount	Aluminum	Page 12	—	—	Page 20	—	—
	Stainless Steel	Consult Factory	—	—	Consult Factory	—	—

### Materials, Hazardous Location

Side Port	Aluminum	—	—	—	—	—	—
	Stainless Steel	—	Page 13	Page 14 - 17	Page 18	Page 22	Page 23
Manifold Mount	Aluminum	Page 10	—	—	Page 20	—	—
	—	—	—	—	Consult Factory	—	—

Solenoid options - Non Hazardous Location ..... Page 4

Solenoid options - Hazardous Locations ..... Page 6

Solenoid - Cross Reference Chart ..... Page 5

### Basic Part Number Code

Series	Body Code				Orifice		Options	Voltage
	3	2	0	1	3	4		
<b>E5SM</b>	<b>3</b>	<b>2</b>	<b>0</b>	<b>1</b>	<b>3</b>	<b>4</b>	<b>H2</b>	<b>A120</b>
E5SM Series Solenoid, Spring Return	Three Way	1/8" NPT	Side Ports	NC	Bottom Orifice Size	Top Orifice Size	Solenoid exhaust adapter	120V60 COIL

Orifice/Cv		
Code	Orifice	Cv
2	1/32"	0.022
3	3/64"	0.06
4	1/16"	0.11
6	3/32"	0.21
8	1/8"	0.26
10	5/32"	0.45
12	3/16"	0.56
16	1/4"	0.79

## The E Family

Versa's E-Series valves are 2 port, 2 position and 3 port, 2 position direct acting pneumatic and hydraulic valves consisting of two body types, side ported and manifold mounted.

E Series Side-Ported valves are individually mounted with body port sizes 1/8" NPT to 1/4" NPT.

Manifold Mounting valve is direct solenoid actuated and is mounted on a manifold which can have 1 to 10 valve stations. The manifolds are provided with the threaded ports for pipe connections, which allows the valves to be easily and swiftly installed or removed without breaking any pipe connections. The manifolds also provide common ports, such as the inlet and exhaust, making only one such connection necessary per manifold.

### Design for Reliability, Flexibility and Availability

#### Vent Options

The standard E Family valve is offered with a threaded vent port. This supports piped exhaust for gases and hydraulic applications. Other vent options are offered to keep contaminants out of the valve for long trouble, free service.

#### Direct Acting Solenoid Design

The E Family of solenoid valves utilize a high performance solenoid direct acting for the perfect balance of flow vs. power. Valves designed for complete pressure range including vacuum.

#### High Heat Epoxy Molded Coils

The E Family solenoid's are high heat rated and are all epoxy molded. A Versa standard! The epoxy molded coil yield a moisture resistance design which also dissipates heat for elevated temperature applications.

#### Electrical Connections

The E Family of solenoid valves offer the widest range of electrical hook connections, from 1/2" conduit to spade terminals and everything in between. All designed to simplify installation and serviceability. Select E Family valves are offered for hazardous location service, should application require such.

#### High Performance Solenoid

Near frictionless direct acting poppet design yields positive shifting, the lowest wattage ratings and unsurpassed reliability. Life cycle ratings to 20 million cycles.

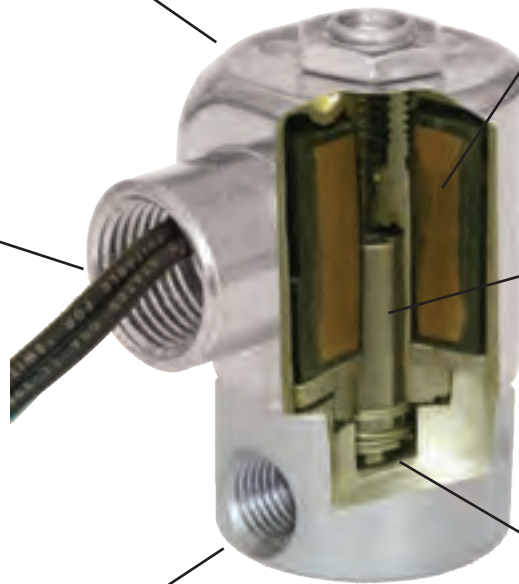

#### Bubble Tight Sealing

The E Family of products utilizes an elastomer sealed poppet. This design offers a bubble tight seal. Many seal materials are available to offer the greatest flexibility in application/media solutions.

#### Porting Options

E Family valves are available with 1/8" or 1/4" ports for ease of installation. Select Families are available in manifolded configurations for ease of installation, space savings and trouble free maintenance.

#### Durable Materials of Construction

E Family materials are available in stainless steel or aluminum to offer the greatest flexibility in application/media solutions.

# SOLENOID SELECTOR General Purpose

## NONHAZARDOUS LOCATION SOLENOIDS

Image	Series	Suffix Detail	Certification-(Conformance)		Ingress Protection	Voltage (Power)	Electrical Characteristics	Miscellaneous
			AC	DC				
	E5SM	Standard -PC	CSA		NEMA 1, 2, 3 & 4	24V60, 120V60, 240V60 (8W) 24V50, 110V50, 220V50 (8W) 12VDC, 24VDC, 48VDC (7W)	Class F epoxy molded coil (155°C). Continuous duty.	Steel cover with 1/2 NPT conduit entry.
	ESM	Standard -PC			NEMA 4; IP65	24V60, 120V60, 240V60 (7.3W) 24V50, 110V50, 220V50 (7.3W) 12VDC, 24VDC, 48VDC (9.5W)		Epoxy molded coil with integral 1/2" npt conduit hub
	EZ E5SM	-228L			NEMA 4	24V60, 120V60, 240V60 (8.5W) 24V50, 110V50, 220V50 (8.5W) 12VDC, 24VDC, 48VDC (10.5W)		Steel cover with grommited (flying) leads. 2 leads 24" (60 cm)
	E5SM		CSA, UL		NEMA 1, 2 & 3	24V60, 120V60, 240V60 (8W) 24V50, 110V50, 220V50 (8W) 12VDC, 24VDC, 48VDC (7W)		Steel cover with grommited (flying) leads 2 leads 24" (60 cm)
	ESM	-243			NEMA 1, 2 & 3	24V60, 120V60, 240V60 (7.3W) 24V50, 110V50, 220V50 (7.3W) 12VDC, 24VDC, 48VDC (9.5W)		flying leads. 2 leads 24" (60 cm)
	EZ		—		NEMA 1, 2 & 3	24V60, 120V60, 240V60 (8.5W) 24V50, 110V50, 220V50 (8.5W) 12VDC, 24VDC, 48VDC (10.5W)		Spade terminals (3). Connector: mini DIN socket with PG9 cable gland.
	EZ E5SM		CSA, UL		NEMA 4	24V60, 120V60, 240V60 (8.5W) 24V50, 110V50, 220V50 (8.5W) 12VDC, 24VDC, 48VDC (10.5W)		Spade terminals (3) Connector pins according to Din 43650 & ISO 4400
	ESM	-HC	—		IP 65	24V60, 120V60, 240V60 (12W) 24V50, 110V50, 220V50 (12W) 12VDC, 24VDC, 48VDC (10W)		Spade terminals (3). Connector: mini DIN socket with PG9 cable gland.
	EZ E5SM				NEMA 4	24V60, 120V60, 240V60 (8.5W) 24V50, 110V50, 220V50 (8.5W) 12VDC, 24VDC, 48VDC (10.5W)		Spade terminals (3). Connector: mini DIN socket with PG9 cable gland.
	ESM	-HCL	CSA, UL		IP 65	24V60, 120V60, 240V60 (12W) 24V50, 110V50, 220V50 (12W) 12VDC, 24VDC, 48VDC (10W)		Spade terminals (3). Connector pins according to Din 43650 & ISO 4400
	EZ E5SM				NEMA 4	24V60, 120V60, 240V60 (8.5W) 24V50, 110V50, 220V50 (8.5W) 12VDC, 24VDC, 48VDC (10.5W)		Spade terminals (3). Connector: mini DIN socket with PG9 cable gland.
	ESM	-HCC	—		IP 65	24V60, 120V60, 240V60 (12W) 24V50, 110V50, 220V50 (12W) 12VDC, 24VDC, 48VDC (10W)		Spade terminals (3). Connector pins according to Din 43650 & ISO 4400
	EZ E5SM		CSA, UL		NEMA 4	24V60, 120V60, 240V60 (8.5W) 24V50, 110V50, 220V50 (8.5W) 12VDC, 24VDC, 48VDC (10.5W)		Spade terminals (3). Connector: mini DIN socket with PG9 cable gland.
	ESM	-HCCL	—		IP65			Spade terminals (3) Connector pins according to Din 43650 & ISO 4400
	ESM	-P	—		NEMA 4; IP65	24V60, 120V60, 240V60 (12W) 24V50, 110V50, 220V50 (12W) 12VDC, 24VDC, 48VDC (10W)	Steel cover with electrical plug-in. A Solenoid which can be removed from subplate or manifold, without disturbing the wiring	

## Combination Suffix Details Cross Reference Chart (E, E4 & E5)

Suffix Reference	
Suffix	Description
-CD	72" wire leads
-D14	Solenoid vent, water proof nut
-H2E	1/8" npt Solenoid vent
-HE	1/4" npt Solenoid vent
-HT	Class H coil
-L14	Solenoid vent dust nut
-LA	0.85 watt Solenoid
-LB	1.8 watt Solenoid
-LV	0.85 watt (World Solenoid)
-LX	1.8 watt (World Solenoid)
-LZ	0.5 watt (World Solenoid)
-PC	Potted coil, NEMA 4
-PS	Potted coil, male conduit;
-ST	Stainless Solenoid housing
-XDBS	World Solenoid**
-XDBT	World Solenoid**
-VJBT	Add on Junction Box
-XN	ATEX Solenoid
-XT	World Solenoid**
-XV	World Solenoid, North America
-XX	North American Solenoid
-303D	Integral diode

North American (-XX) (Cont.)	
Combination Suffix	Included Suffix
-XXK	-XX, -HT, -LB, -PC, -ST
-XXK4	-XX, -D14, -HT, -LB, -PC, -ST
-XXL	-XX, -PC
-XXL4	-XX, -D14, -PC
-XXM	-XX, -HT, -PC
-XXM4	-XX, -D14, -HT, -PC
-XXN	-XX, -LB, -PC
-XXN4	-XX, -D14, -LB, -PC
-XXP	-XX, -HT, -LB, -PC
-XXP4	-XX, -D14, -HT, -LB, -PC
-XXQ	-XX, -HT, -LB
-XXQ4	-XX, -D14, -HT, -LB
-XXR	-XX, -LB
-XXR4	-XX, -D14, -LB
-XXS	-XX, -LA, -ST
-XXS4	-XX, -D14, -LA, -ST
-XXU	-XX, -HT, -LB, -ST
-XXU4	-XX, -D14, -HT, -LB, -ST
-XXV	-XX, -LA
-XXV4	-XX, -D14, -LA
-XXW	-XX, -CD, -HT, -H2, -PC, -ST
-XXW4	-XX, -D14, -CD, -HT, -PC, -ST

ATEX (-XN) (Cont.)	
Combination Suffix	Included Suffix
-XNQ	-XN, -HT, -LB
-XNR	-XN, -LB
-XNS	-XN, -LA, -ST
-XNU	-XN, -HT, -LB, -ST
-XNV	-XN, -LA
-XNX	-XN, -LB, -PS
-XNWS	-XN, -VJBT, -LB, -PS

World Solenoid (-XDB, -XT, -XV)		
Combination Suffix		Included Suffix
1.8 Watt	0.85 Watt	
-XDBS1	-XDBS1C	-XDBS, -HT, -LX
-XDBS2	-XDBS2C	-XDBS, -HT, -LX, -H2E
-XDBS3	-XDBS3C	-XDBS, -HT, -LX, -HE
-XDBS4	-XDBS4C	-XDBS, -HT, -LX, -L14
-XDBS5	-XDBS5C	-XDBS, -HT, -LX, -303D
-XDBS6	-XDBS6C	-XDBS, -HT, -LX, -H2E, -303D
-XDBS7	-XDBS7C	-XDBS, -HT, -LX, -HE, -303D
-XDBS8	-XDBS8C	-XDBS, -HT, -LX, -L14, -303D
-XDBS9	-XDBS9C	-XDBS, -HT, -LX, -D14
-XDBS10	-XDBS10C	-XDBS, -HT, -LX, -D14, -303D
-XDBT1	-XDBT1C	-XDBT, -HT, -LX
-XDBT2	-XDBT2C	-XDBT, -HT, -LX, -H2E
-XDBT3	-XDBT3C	-XDBT, -HT, -LX, -HE
-XDBT4	-XDBT4C	-XDBT, -HT, -LX, -L14
-XDBT5	-XDBT5C	-XDBT, -HT, -LX, -303D
-XDBT6	-XDBT6C	-XDBT, -HT, -LX, -H2E, -303D
-XDBT7	-XDBT7C	-XDBT, -HT, -LX, -HE, -303D
-XDBT8	-XDBT8C	-XDBT, -HT, -LX, -L14, -303D
-XDBT9	-XDBT9C	-XDBT, -HT, -LX, -D14
-XDBT10	-XDBT10C	-XDBT, -HT, -LX, -D14, -303D
-XV1	-XV1C	-XV, -HT, -LX
-XV2	-XV2C	-XV, -HT, -LX, -H2E
-XV3	-XV3C	-XV, -HT, -LX, -HE
-XV4	-XV4C	-XV, -HT, -LX, -L14
-XV9	-XV9C	-XV, -HT, -LX, -D14
-XT1	-XT1C	-XT, -HT, -LX
-XT2	-XT2C	-XT, -HT, -LX, -H2E
-XT3	-XT3C	-XT, -HT, -LX, -HE
-XT4	-XT4C	-XT, -HT, -LX, -L14
-XT9	-XT9C	-XT, -HT, -LX, -D14

North American (-XX)	
Combination Suffix	Included Suffix
-XXA	-XX, -HT
-XXA4	-XX, -D14, -HT
-XXB	-XX, -PS
-XXB4	-XX, -D14, -PS
-XXC	-XX, -HT, -PS
-XXC4	-XX, -D14, -HT, -PS
-XXD	-XX, -ST
-XXD4	-XX, -D14, -ST
-XXE	-XX, -PC, -ST
-XXE4	-XX, -D14, -PC, -ST
-XXF	-XX, -HT, -ST
-XXF4	-XX, -D14, -HT, -ST
-XXG	-XX, -LB, -ST
-XXG4	-XX, -D14, -LB, -ST
-XXH	-XX, -HT, -PC, -ST
-XXH4	-XX, -D14, -HT, -PC, -ST
-XXJ	-XX, -LB, -PC, -ST
-XXJ4	-XX, -D14, -LB, -PC, -ST

ATEX (-XN)	
Combination Suffix	Included Suffix
-XNA	-XN, -HT
-XND	-XN, -ST
-XNE	-XN, -PC, -ST
-XNE4	-XN, -D14, -PC, -ST
-XNF	-XN, -HT, -ST
-XNG	-XN, -LB, -ST
-XNH	-XN, -HT, -PC, -ST
-XNJ	-XN, -LB, -PC, -ST
-XNJ4	-XN, -D14, -LB, -PC, -ST
-XNK	-XN, -HT, -LB, -PC, -ST
-XNL	-XN, -PC
-XNL4	-XN, -D14, -PC
-XNM	-XN, -HT, -PC
-XNN	-XN, -LB, -PC
-XNN4	-XN, -D14, -LB, -PC
-XNP	-XN, -HT, -LB, -PC

### Recommended Hazardous Location Solenoid Option Packages

Series	Enclosure/Wire	Certification/Power			
		North American - CSA		ATEX - IECEx - INMETRO	
		Standard Power	Low Watt*	Standard Power	Low Watt*
E	Steel, Electroless Nickel Plated, 24 Inch Leads	-XXL4	n/a	n/a	n/a
E5	Steel, Electroless Nickel Plated, 24 Inch Leads	-XXL4	XXN4	-XNL4	-XNN4
	Stainless Steel, 24" wire leads	-XXE4	n/a	-XNE4	n/a
E4	Stainless Steel, High Performance 430 type, 24" wire leads	n/a	-XV9	n/a	-XT9**
	Stainless Steel, 316L type, Junction Box with Terminal Strip	n/a	-XDBT9**	n/a	-XDBS9**











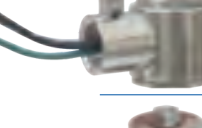

\*1.8 watt solenoid. Also available is 0.85 watt, see cross reference chart above, 1.8 & 0.85 not available on E. For 0.50 watt, consult factory.

\*\*All the -XDBS, -XDBT & -XT solenoids are "World Solenoids" certified for North America, ATEX, IECEx and INMETRO. For additional certifications consult factory. -XV solenoids certified for North America.

# SOLENOID SELECTOR Hazardous Location

E Series valves are available with a variety of different solenoids for both nonhazardous and hazardous locations. Basic details of actuators are listed below and on page 8. For additional data consult factory.

## Hazardous Location Solenoids

			Agency Approvals					
			North America		World*			
			SP		Ex IEC			
Series	Suffix*	Protection Classification	Zones	Divisions	Area Classification and (Gas Grouping)	Agency	Ingress Protection	
	ESM	-XX	Hazardous Locations	CL I, DIV 1, Grp (C & D) CL II, DIV 1, Grp (E, F & G) Temp T3C	—	UL CSA	NEMA 7 & 9	
	E5	-XX						
		-XN	(d) Flameproof	—	—	Ex d IIB+H2 T3...T6 Gb II 2 G Ex d IIB+H2 T3...T6 Gb	IECEX ATEX	IP66/67
		-XV	Hazardous Locations	—	—	—	cCSA <sub>us</sub>	NEMA 4, 4X, 6P, IP66
	E4	-XT	(d) Flameproof	CL I, DIV 1, Grp (B, C, D) CL II, DIV 1, Grp (E, F, G) CL III CL I, DIV 2, Grp (A, B, C, D) CL II, DIV 1, Grp (E, F, G) CL III	CL, I, Zn 1 A/Ex de IIC T CL, II Zn, 21 AEx tD A21, DIP A21	Ex II 2 G D A/Ex d e IIC T3...T6 Gb Ex tb IIIC T3...T6 Db	ATEX, IECEX, INMETRO	IP66/67/68
		-XDBT	(d) Flameproof (e) Increased Safety	—				
	ESM	-XMAA -XMAF	(mb) Encapsulation (e) Increased Safety	—	Ex e mb IIC T5, T6 Gb Ex tb IIIC T85°C, T100°C Db	IECEX TR CU ATEX	IP67	
		-XMFA -XMFF	(tD) Tight Dust	II 2 G Ex e mb IIC T5...T6 Gb II 2 D Ex tb IIIC T85°C...T100°C Db				
		-XIFA -XIFF	(ia) Intrinsic Safe	—	Ex (ia) IIC T4...T6 Gb Ex (ia) IIIC T130°C...T80°C Db	IECEX TR CU ATEX	IP67	
	E5	-XISX6	Intrinsic Safe	—	II 2 G Ex ia IIC T4...T6 Gb II 2 G Ex ia IIB T4...T6 Gb	ATEX IECEX TR CU	IP65	
		-XISC		—	CL I, DIV 1, Grp (A, B, C & D) CL II, DIV 1, Grp (E, F, & G) CL III			
	E3	XPN LC-XPS -XPS LC-XPS	Factory Sealed	—	CL I, Div 1, Grp (C & D) CL II, Div 1, Grp (E, F & G), T6 CL I, Div 2, Grp (C & D) CL II, Div 2, Grp (E, F & G)	II 2 G Ex ia IIC T4...T6 Gb II 2 G Ex ia IIB T4...T6 Gb	CSA	4X & 6P

\*For recommended solenoid options. See page 5

**COIL CODES:** Identify the solenoid frequency and voltage, consisting of a "Rating Code" and "Voltage" as shown at right. Coil codes complete the part number for a solenoid operated valve.

**Rating Code**  
 A = 60Hz frequency  
 D = Direct Current (DC)  
 E = 50Hz frequency

**Voltage**  
 Indicated by three digits:  
 e.g. 24 volts = 024  
 120 volts = 120

**A120 = AC, 120Volts/60hz**

Voltage (Power)	Electrical Characteristics	Miscellaneous																																					
50 Hz & 60 Hz AC (7.3W), DC (9.5W) AC: 12V60, 24V60, 48V60, 120V60, 240V60 DC: 6VDC, 12VDC, 24VDC, 48VDC	Class F epoxy molded coil (155°C). continuous duty. 3 leads 24" (60 cm).	Plated steel coil housing with 1/2 NPT conduit entry. For additional solenoid options see pages 5																																					
50 Hz & 60 Hz AC (6W), DC (7.2W) & (1.8W) AC: 12V60 (A012), 24V60 (A024), 48V60 (A048), 120V60 (A120), 240V60 (A120) DC: 6VDC (D006), 12VDC (D012), 24VDC (D024), 48VDC (D048)		Plated steel coil housing with 1/2 NPT conduit entry. For additional solenoid options see pages 5																																					
DC: 6VDC (D006), 12VDC (D012), 24VDC (D024), 48VDC (D048)		Plated steel coil housing with M20 x 1.5 conduit entry. Ground terminal on cover. For additional solenoid options see pages 5																																					
AC: 120V60HZ (A120), 240V60HZ (A240) 110V50HZ (E110), 220V50HZ (E230) DC: 12VDC (D012), 24VDC (D024) 48VDC (D048), 120VDC (D120)  1.8 watt standard. For 0.85 watt consult factory.	Epoxy molded coils rated for continuous duty, Class H (180°C).	<table border="1"> <thead> <tr> <th rowspan="2">Stainless steel coil housing with 1/2" NPT conduit connection.</th> <th colspan="2">Suffix Detail Ordering Code</th> </tr> <tr> <th>XV</th> <th>XT</th> </tr> </thead> <tbody> <tr> <td>Standard (vent to atmosphere)</td> <td>-XV1</td> <td>-XT1</td> </tr> <tr> <td>1/8" Adapter (-H2E)</td> <td>-XV2</td> <td>-XT2</td> </tr> <tr> <td>1/4" Adapter (-HE)</td> <td>-XV3</td> <td>-XT3</td> </tr> <tr> <td>Dust Nut (-L14)</td> <td>-XV4</td> <td>-XT4</td> </tr> <tr> <td>Water proof nut (-D14)</td> <td><b>-XV9*</b></td> <td><b>-XT9*</b></td> </tr> </tbody> </table>	Stainless steel coil housing with 1/2" NPT conduit connection.	Suffix Detail Ordering Code		XV	XT	Standard (vent to atmosphere)	-XV1	-XT1	1/8" Adapter (-H2E)	-XV2	-XT2	1/4" Adapter (-HE)	-XV3	-XT3	Dust Nut (-L14)	-XV4	-XT4	Water proof nut (-D14)	<b>-XV9*</b>	<b>-XT9*</b>																	
		Stainless steel coil housing with 1/2" NPT conduit connection.		Suffix Detail Ordering Code																																			
			XV	XT																																			
Standard (vent to atmosphere)	-XV1	-XT1																																					
1/8" Adapter (-H2E)	-XV2	-XT2																																					
1/4" Adapter (-HE)	-XV3	-XT3																																					
Dust Nut (-L14)	-XV4	-XT4																																					
Water proof nut (-D14)	<b>-XV9*</b>	<b>-XT9*</b>																																					
<table border="1"> <thead> <tr> <th rowspan="2">Stainless steel coil housing with internal Junction Box. Internal and external ground screw.</th> <th colspan="4">Suffix Detail Ordering Code</th> </tr> <tr> <th colspan="2">M 20 Connection</th> <th colspan="2">1/2" Connection</th> </tr> <tr> <td>Standard (vent to atmosphere)</td> <td>No Diode</td> <td>Diode</td> <td>No Diode</td> <td>Diode</td> </tr> </thead> <tbody> <tr> <td>1/8" Adapter (-H2E)</td> <td>XDBS1</td> <td>XDBS5</td> <td>XDBT1</td> <td>XDBT5</td> </tr> <tr> <td>1/4" Adapter (-HE)</td> <td>XDBS2</td> <td>XDBS6</td> <td>XDBT2</td> <td>XDBT6</td> </tr> <tr> <td>1/4" Adapter (-HE)</td> <td>XDBS3</td> <td>XDBS7</td> <td>XDBT3</td> <td>XDBT7</td> </tr> <tr> <td>Dust Nut (-L14)</td> <td>XDBS4</td> <td>XDBS8</td> <td>XDBT4</td> <td>XDBT8</td> </tr> <tr> <td>Dust Excluder (-D14)</td> <td><b>XDBS9*</b></td> <td><b>XDBS10</b></td> <td><b>XDBT9*</b></td> <td><b>XDBT10*</b></td> </tr> </tbody> </table>	Stainless steel coil housing with internal Junction Box. Internal and external ground screw.	Suffix Detail Ordering Code				M 20 Connection		1/2" Connection		Standard (vent to atmosphere)	No Diode	Diode	No Diode	Diode	1/8" Adapter (-H2E)	XDBS1	XDBS5	XDBT1	XDBT5	1/4" Adapter (-HE)	XDBS2	XDBS6	XDBT2	XDBT6	1/4" Adapter (-HE)	XDBS3	XDBS7	XDBT3	XDBT7	Dust Nut (-L14)	XDBS4	XDBS8	XDBT4	XDBT8	Dust Excluder (-D14)	<b>XDBS9*</b>	<b>XDBS10</b>	<b>XDBT9*</b>	<b>XDBT10*</b>
Stainless steel coil housing with internal Junction Box. Internal and external ground screw.		Suffix Detail Ordering Code																																					
	M 20 Connection		1/2" Connection																																				
Standard (vent to atmosphere)	No Diode	Diode	No Diode	Diode																																			
1/8" Adapter (-H2E)	XDBS1	XDBS5	XDBT1	XDBT5																																			
1/4" Adapter (-HE)	XDBS2	XDBS6	XDBT2	XDBT6																																			
1/4" Adapter (-HE)	XDBS3	XDBS7	XDBT3	XDBT7																																			
Dust Nut (-L14)	XDBS4	XDBS8	XDBT4	XDBT8																																			
Dust Excluder (-D14)	<b>XDBS9*</b>	<b>XDBS10</b>	<b>XDBT9*</b>	<b>XDBT10*</b>																																			
24VDC (4W) (Consult factory for other voltage options)	Continuous duty coil & rectifier, including surge suppression, potted within housing.	Thick wall epoxy coil housing with integral junction box. Internal ground terminal.																																					
24VDC 10W inrush, 2.6W holding) (Consult factory for other voltages)	Continuous duty coil & power controller potted within housing.	M20 x 1.5 conduit entry: (-XMAA), (-XMFA), 1/2 NPT conduit entry with adapter: (-XMAF), (-XMFF)																																					
24VDC (0.8W) (Consult factory for other voltages)	Continuous duty coil and power controller potted within housing.	Requires the use of an approved safety barrier or isolator. Thick wall epoxy coil housing and integral junction box. Internal ground terminal. M20 x 1.5 conduit entry: (-XIFA) 1/2 NPT conduit entry with adapter: (-XIFF)																																					
24VDC (1.6 watt max.) System voltage prior to barrier	Class F epoxy molded coil (155°C). Continuous duty.	Requires the use of an approved barrier or isolator. Maximum operating system voltage before barrier 28VDC. Maximum pilot pressure 115 psi (8 bar). 3 spade terminals, ISO DIN 43650, Form "A" PG9 cable gland (-HC) 1/2 NPT conduit entry: (-HCC)																																					
1.8 watts 0.85 watt, 12 or 24 DC	Class F, Continuous duty	Coil: 1/2" NPT, male hub with 72 inch wire leads, 3 wire. Not polarity dependent Epoxy molded/encapsulated (Factory Sealed), Inline off conduit hub. Not orientation sensitive, coil housing and body 316 stainless steel with FKM seal																																					

\*Bold, recommended solenoid options. See page 5 for additional options.

# SERIES EZ

## Side Ported Types

Series EZ valves are direct solenoid actuated valves and, physically, are the smallest of the Series E type valves. Ports are 1/8" NPT in the valve body and are individually mounted. See below for technical data.

Series EZ Bantam Multiple Manifold valves are direct solenoid actuated and have 2 to 10 valve cavities within a single body. Each valve within the manifold must be the same and perform the same function. See page 12 for part number example.

<u>Functional Types Available</u>	<u>Ports Provided</u>
2-way, NC or NO.....	Common inlet, individual outlets
3-way, NC.....	Common inlet, individual outlets, exhaust to atmosphere. Common exhaust is available.
3-way, NO.....	Common inlet & exhaust, individual outlets
Multipurpose.....	Individual "NC," "COM," & "NO" ports

Function	2-Way NC, 2-Way NO, 3-Way NC, 3-Way NO, Directional & Multi-Purpose
Pressure:	Vacuum - 500
Media	Air, Oil, Water
Flow:	to 0.21 Cv
Temperature:	0°F (-18°C) to 180°F (82°C)
Ports, Inlet & Outlet:	1/8" NPT
Exhaust/vent:	Vent to atmosphere, #10-32 thread (NPT port or dust protectors available)
Voltages:	AC or DC (see page 4)
Coil rating:	Class F, continuous duty
Power:	8.5 - 10 .5 Watts
Connections:	DIN standard (-HC), Flying Leads (-243) or 1/2" NPT conduit Hub (-228L) optional
Ingress protection:	IP65 (-HC), NEMA 1 - 3 (-243), NEMA 4 (-228L)
Materials of construction:	
Body:	Aluminum
Seals:	FKM (fluorocarbon)
Coil:	Epoxy molded, Class F, continuous duty
Manifold:	Aluminum
Mounting:	(2) threaded holes



Shown with  
-HC, -H2



Shown with  
-243

1/2" NPT Conduit Hub

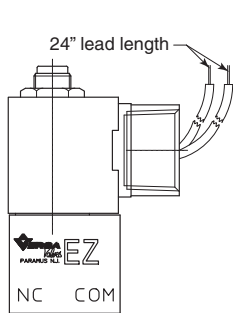

DIN with PG-9 Cord Grip

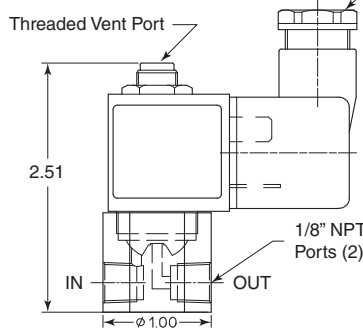

Flying Leads

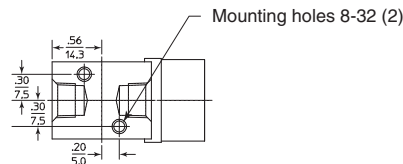
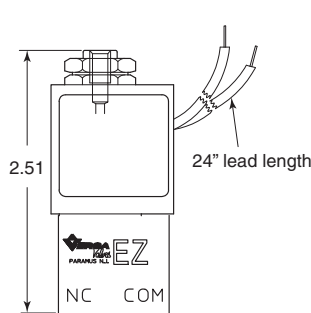

Orifice/Cv		
Code	Orifice	Cv
2	1/32"	0.022
3	3/64"	0.06
4	1/16"	0.11
6	3/32"	0.21

(STANDARD DIN STYLE COIL & CONNECTOR)

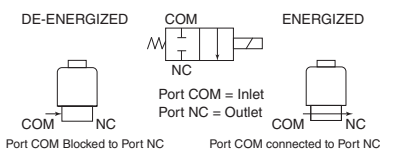
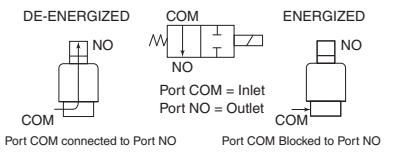
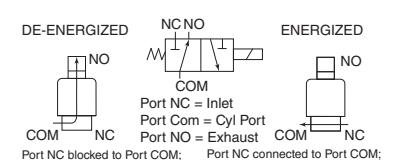
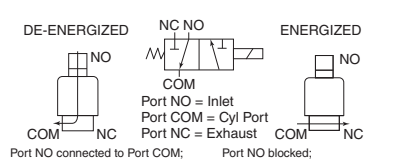
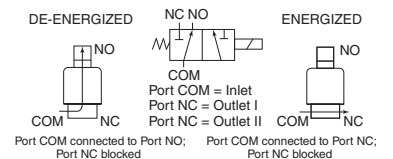
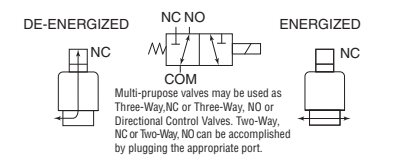

SIDE PORTED VALVES					
Type	Maximum Operating Pressure Differential psi (bar)†	Product Number with Micromini DIN Style Connector (8 mm gap). For other housing options see page 4.	Minimum Orifice between Ports		Piping Arrangement and Flow Pattern
			"NC" - "COM"	"COM" - "NO"	
TWO-WAY 2/2 NORMALLY CLOSED Air, Oil or Water	500 (34) 400 (27) 200 (14) 150-100 (10-6.8) 65-45 (4.4-3.1)	EZ-2120-0-HC-(*) EZ-2130-0-HC-(*) EZ-2140-0-HC-(*) EZ-2204-H2-HC-(*) EZ-2180-0-HC-(*)	1/32" (0.8 mm) 3/64" (1.2 mm) 1/16" (1.6 mm) 3/32" (2.4 mm) 1/8" (3.2 mm)		 <p>DE-ENERGIZED      COM      ENERGIZED</p> <p>Port COM = Inlet Port NC = Outlet</p> <p>Port COM Blocked to Port NC      Port COM connected to Port NC</p>
TWO-WAY 2/2 NORMALLY OPEN Air, Oil or Water	400 (27) 200 (14) 125 (8.6) 40 (2.7)	EZ-2202-H2-HC-(*) EZ-2203-H2-HC-(*) EZ-2204-H2-HC-(*) EZ-2206-H2-HC-(*)		1/32" (0.8 mm) 3/64" (1.2 mm) 1/16" (1.6 mm) 3/32" (2.4 mm)	 <p>DE-ENERGIZED      COM      ENERGIZED</p> <p>Port COM = Inlet Port NO = Outlet</p> <p>Port COM connected to Port NO      Port COM Blocked to Port NO</p>
THREE-WAY 3/2 NORMALLY CLOSED (EXHAUST TO ATMOSPHERE) Air Only	200 (14) 150 (10) 100 (6.9) 50 (3.4) 30 (2.1)	EZ-3122-1-HC-(*) EZ-3133-1-HC-(*) EZ-3144-1-HC-(*) EZ-3166-1-HC-(*) EZ-3186-1-HC-(*)	1/32" (0.8 mm) 3/64" (1.2 mm) 1/16" (1.6 mm) 3/32" (2.4 mm) 1/8" (3.2 mm)	1/32" (0.8 mm) 3/64" (1.2 mm) 1/16" (1.6 mm) 3/32" (2.4 mm) 3/32" (2.4 mm)	 <p>DE-ENERGIZED      NC NO      ENERGIZED</p> <p>Port NC = Inlet Port COM = Cyl Port Port NO = Exhaust</p> <p>Port NC blocked to Port COM; Port NC connected to Port COM; Port COM connected to Port NO      Port NO blocked</p>
THREE-WAY 3/2 NORMALLY CLOSED (PIPED EXHAUST) Air, Oil or Water	200 (14) 150 (10) 100 (6.9) 50 (3.4) 30 (2.1)	EZ-3122-H2-HC-(*) EZ-3133-H2-HC-(*) EZ-3144-H2-HC-(*) EZ-3166-H2-HC-(*) EZ-3186-H2-HC-(*)	1/32" (0.8 mm) 3/64" (1.2 mm) 1/16" (1.6 mm) 3/32" (2.4 mm) 1/8" (3.2 mm)	1/32" (0.8 mm) 3/64" (1.2 mm) 1/16" (1.6 mm) 3/32" (2.4 mm) 3/32" (2.4 mm)	 <p>DE-ENERGIZED      NC NO      ENERGIZED</p> <p>Port NO = Inlet Port COM = Cyl Port Port NC = Exhaust</p> <p>Port NO connected to Port COM; Port NO blocked; Port NC blocked; Port COM connected to Port NC</p>
DIRECTIONAL CONTROL 3/2 Air, Oil or Water	300-200 (20-14) 200-150 (14-10) 100-75 (6.9-5.2) 75-40 (5.2-2.7)	EZ-7222-H2-HC-(*) EZ-7233-H2-HC-(*) EZ-7244-H2-HC-(*) EZ-7266-H2-HC-(*)	1/32" (0.8 mm) 3/64" (1.2 mm) 1/16" (1.6 mm) 3/32" (2.4 mm)	1/32" (0.8 mm) 3/64" (1.2 mm) 1/16" (1.6 mm) 3/32" (2.4 mm)	 <p>DE-ENERGIZED      NC NO      ENERGIZED</p> <p>Port COM = Inlet Port NC = Outlet I Port NC = Outlet II</p> <p>Port COM connected to Port NO; Port COM connected to Port NC; Port NC blocked      Port NC blocked</p>
MULTI-PURPOSE 3/2 Air, Oil or Water	125 (8.6) 100 (6.9) 65-50 (4.4-3.4) 25 (1.7)	EZ-8222-H2-HC-(*) EZ-8233-H2-HC-(*) EZ-8244-H2-HC-(*) EZ-8266-H2-HC-(*)	1/32" (0.8 mm) 3/64" (1.2 mm) 1/16" (1.6 mm) 3/32" (2.4 mm)	1/32" (0.8 mm) 3/64" (1.2 mm) 1/16" (1.6 mm) 3/32" (2.4 mm)	 <p>DE-ENERGIZED      NC NO      ENERGIZED</p> <p>Multi-purpose valves may be used as Three-Way, NC or Three-Way, NO or Directional Control Valves. Two-Way, NC or Two-Way, NO can be accomplished by plugging the appropriate port.</p>

**NOTES:**

\*Specify Voltage: See "Coil Code" definition page 7.  
For coil voltages see page 4.

†Pressures are for both AC or DC coil unless two pressures are shown. In that case, the pressure in color is for DC. Vacuum is AC only.

# SERIES EZ

## Manifold-Mounting

MULTIPLE MANIFOLD TYPE VALVES (2-10 VALVES)					
Type	Maximum Operating Pressure Differential psi (bar)†	Product Number with Micromini DIN Style Connector (8 mm gap). For Other Options See Page 4.	Minimum Orifice Between Ports		Piping Arrangement
			"NC"- "COM"	"COM"- "NO"	
<b>TWO-WAY, 2/2 Normally Closed</b> with Common Inlet Air, Oil or Water	150 (10) 100 (6.8) 60 (4.1) 30 (2.1)	EZM-2130-**-0-HC-(*) EZM-2140-**-0-HC-(*) EZM-2160-**-0-HC-(*) EZM-2180-**-0-HC-(*)	3/64" (1.2 mm) 1/16" (1.6 mm) 3/32" (2.4 mm) 1/8" (3.2 mm)		"NC" port = Common Inlet for a)) valves "COM" port = Individual Outlet for each valve
<b>TWO-WAY, 2/2 Normally Open</b> with Common Inlet Air, Oil or Water	200 (14) 125 (8.6) 40 (2.7)	EZM-2203-**-Z-HC-(*) EZM-2204-**-Z-HC-(*) EZM-2206-**-Z-HC-(*)		3/64" (1.2 mm) 1/16" (1.6 mm) 3/32" (2.4 mm)	"NO" port = Common Inlet for all valves "COM" port = Individual outlet for each valve
<b>THREE-WAY, 3/2 Normally Closed</b> (Exhaust to atmosphere) with Common Inlet Air Only	150 (10) 100 (6.8) 50 (3.4) 30 (2.1)	EZM-3133-**-1-HC-(*) EZM-3144-**-1-HC-(*) EZM-3166-**-1-HC-(*) EZM_3186-**-1-HC-(*)	3/64" (1.2 mm) 1/16" (1.6 mm) 3/32" (2.4 mm) 3/32" (2.4 mm)	3/64" (1.2 mm) 1/16" (1.6 mm) 3/32" (2.4 mm) 1/8" (3.2 mm)	"NC" port = Common Inlet for all valves "COM" port = Individual outlet for each valve "NO" port = Individual exhaust for each valve
<b>THREE-WAY, 3/2 Normally Closed</b> (Piped exhaust) with Common Inlet & Common Exhaust Air, Oil or Water	150 (10) 100 (6.8) 50 (3.4) 30 (2.1)	EZM-3133-**-Z-HC-(*) EZM-3144-**-Z-HC-(*) EZM-3166-**-Z-HC-(*) EZM-3186-**-Z-HC-(*)	3/64" (1.2 mm) 1/16" (1.6 mm) 3/32" (2.4 mm) 1/8" (3.2 mm)	3/64" (1.2 mm) 1/16" (1.6 mm) 3/32" (2.4 mm) 3/32" (2.4 mm)	"NC" port = Common Inlet for a)) valves "COM" port = Individual Outlet for each valve "NO" port = Common Exhaust for all valves
<b>THREE-WAY, 3/2 Normally Open</b> with Common Inlet & Common Exhaust Air, Oil or Water	125 (8.6) 100 (6.8) 50 (3.4)	EZM-3233-**-Z-HC-(*) EZM-3244-**-Z-HC-(*) EZM-3266-**-Z-HC-(*)	3/64" (1.2 mm) 1/16" (1.6 mm) 3/32" (2.4 mm)	3/64" (1.2 mm) 1/16" (1.6 mm) 3/32" (2.4 mm)	"NO" port = Common Inlet for all valves "COM" port = Individual Outlet for each valve "NO" port = Common Exhaust for all valves
<b>MULTIPURPOSE, 3/2</b> with Common "NC" Port Air, Oil or Water	100 (6.8) 65-50 (4.4-3.4) 25 (1.7)	EZM-8233-**-†-HC-(*) EZM-8244-**-†-HC-(*) EZM-8266-**-†-HC-(*)	3/64" (1.2 mm) 1/16" (1.6 mm) 3/32" (2.4 mm)	3/64" (1.2 mm) 1/16" (1.6 mm) 3/32" (2.4 mm)	The Function Table below lists all the possible valve functions which can be obtained by just changing the connections

**NOTES:**

\*Specify Voltage: See "Coil Code" definition page 7.

For coil voltages see page 4.

\*\*Specify number of valve stations required, 2 thru 10.

†Pressures are for both AC or DC coil unless two pressures are shown. In that case, the pressure shown in color is for DC.

- 1— "NO" valve ports are un-piped and exchange to atmosphere.
- H2— Each "NO" valve port is provided with a 1/8" NPT adapter for piping each "NO" port individually.
- Z— "NO" ports of all valves are connected to a common "NO" port in the manifold.



Function Table						
Port	2-Way NO	2-Way NC	3-Way NO	3-Way NC	Selector	Diverter
NC	Plug	Inlet	Exhaust	Inlet	Inlet	Outlet
NO	Inlet	Plug	Inlet	Exhaust	Inlet	Outlet
COM	Outlet	Outlet	Outlet	Outlet	Outlet	Inlet

Orifice/Cv		
Code	Orifice	Cv
2	1/32"	0.022
3	3/64"	0.06
4	1/16"	0.11
6	3/32"	0.21

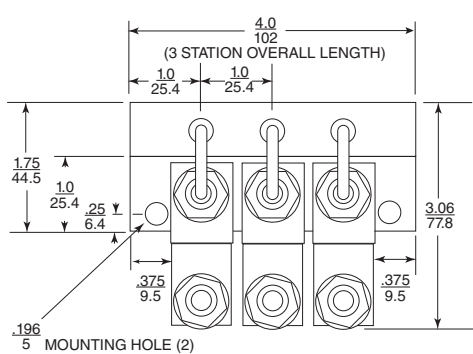

**Typical Multiple Manifold**

(Shows common "NO" port arrangement and micromini DIN style connector)

DIMENSIONS: (SHOWN IN INCH / MM)

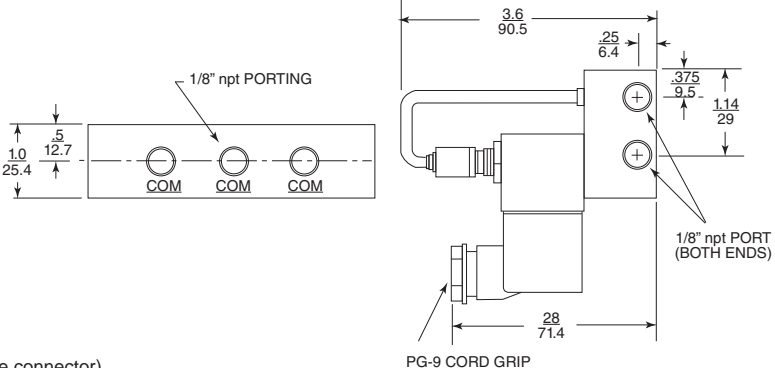

PG-9 CORD GRIP

# SERIES E5

## Side Ported Types



Series E5 compact valves are direct acting solenoid actuated Valves. They are physically smaller than the Series E full-size valves described on pages 18 through 21, but offer most of the same orifice sizes and operating pressure ranges as the larger valves. Ports are 1/8 NPT in the valve body and the valves are individually mounted.

Function:	2-Way NC, 2-Way NO, 3-Way NC, 3-Way NO, Directional & Multi-Purpose
Pressure:	to 500 psi (see table page 13 - 14)
Media:	Air, Oil, Water
Flow:	to 0.26 Cv
Temperature:	0°F to 180°F (-18°C to 82°C)
Ports, Inlet & Outlet:	1/8" or 1/4" NPT
Exhaust/vent:	Vent to atmosphere, #10-32 thread (NPT port or dust protectors available)
Voltages:	AC or DC (General Purpose see page 4) (Hazardous Location see page 7)
Coil rating:	Class F, continuous duty (Class H optional)
Power:	8.5 - 10.5 watt
Connections:	1/2" NPT
Ingress protection:	NEMA 1, 2,3 & 4/4X, General Purpose NEMA 1, 2,3 & 4/4X, Hazardous Location NEMA 7, 9, 4/4X, FM & ATEX
Materials of construction:	
Body:	430 Stainless (316 Stainless Steel optional)
Seals:	NBR (Nitrile)
Coil:	Epoxy molded
Mounting:	(2) threaded holes (optional bracket -WMA)

### GENERAL PURPOSE COILS (NEMA 1, 2, 3)

1/8" NPT Ports

1/4" NPT Ports

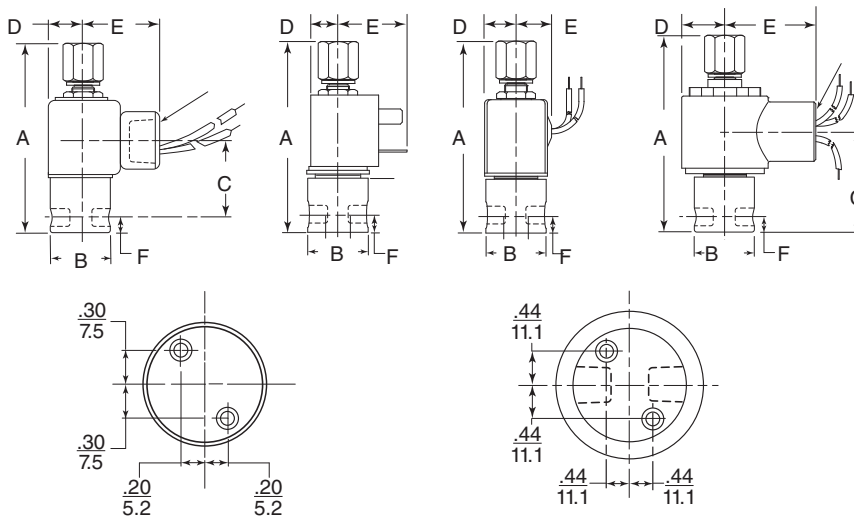

1/8" Body      Mounting Hole Dimension      1/4" Body

### HAZARDOUS LOCATION COILS (NEMA 7 & 9)



1/8" NPT Ports



1/4" NPT Ports

		A		B		C		D		E		F	
		IN	mm	IN	mm	IN	mm	IN	mm	IN	mm	IN	mm
1/8" Ports	-HC	3	76.2	1	25.4	1.6	40.6	2.9	73.7	0.67	17	0.3	7.6
	-243	3	76.2	1	25.4	—	—	0.52	13.2	0.69	17.5	0.3	7.6
	STD	3	76.2	1	25.4	1.26	32	0.52	13.2	1.34	34	0.3	7.6
	-XX -XN	3.28	83	1	25.4	1.35	34.3	0.72	18.2	1.5	38.5	0.3	7.6
1/4" Ports	-HC	3.07	78	1.34	.34	1.4	35.6	.75	19	0.67	17	0.34	8.6
	-243	3.2	81.2	1.34	.34	—	—	0.52	13.2	0.69	17.5	0.34	8.6
	STD	3.2	81.2	1.34	.34	1.09	27.7	0.52	13.2	1.34	34.1	0.34	8.6
	XX -XN	3.3	83	1.34	.34	1.48	37.6	0.72	18.3	1.5	38.5	0.34	8.6

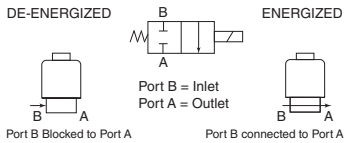
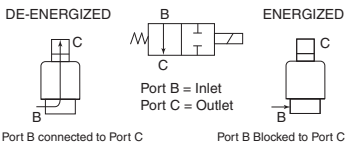
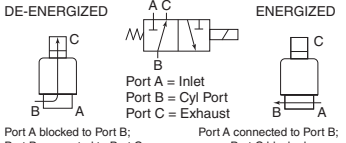
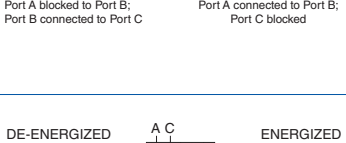
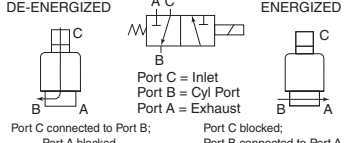
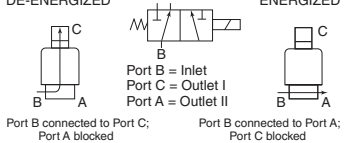
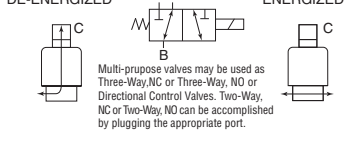

# SERIES E5

## Side Ported Types

Type	Maximum Operating Pressure Differential psi (bar)		General Purpose (For Coil Voltages See Page 4)		Min. Orifice between Ports		Piping Arrangement and Flow Pattern
			Product Number				
	AC	DC	1/8" BODY PORTS	1/4" BODY PORTS	"A"- "B"	"B"- "C"	
<b>TWO-WAY 2/2 NORMALLY CLOSED</b> Air, Oil or Water	500 (34) 400 (27) 200 (14) 100 (6.9) 75 (5.2)	250 (17) 150 (10) 100 (6.9) 45 (3.1) 25 (1.7)	<b>E5SM-2201-20-(* E5SM-2201-30-(* E5SM-2201-40-(* E5SM-2201-60-(* E5SM-2201-80-(*</b>	<b>E5SM-2301-20-(* E5SM-2301-30-(* E5SM-2301-40-(* E5SM-2301-60-(* E5SM-2301-80-(*</b>	1/32" (0.8 mm) 3/64" (1.2 mm) 1/16" (1.6 mm) 3/32" (2.4 mm) 1/8" (3.2 mm)		
<b>TWO-WAY 2/2 NORMALLY OPEN</b> Air, Oil or Water	400 (27) 200 (14) 125 (8.6)	200 (14) 100 (6.9) 60 (4.1)	<b>E5SM-2202-03-H2-(* E5SM-2202-04-H2-(* E5SM-2202-06-H2-(*</b>	<b>E5SM-2302-03-H2-(* E5SM-2302-04-H2-(* E5SM-2202-06-H2-(*</b>		1/32" (0.8 mm) 3/64" (1.2 mm) 1/16" (1.6 mm)	
<b>THREE-WAY 3/2 NORMALLY CLOSED (EXHAUST TO ATMOSPHERE)</b> Air Only	200 (14) 150 (10) 150 (10) 100 (6.9) 60 (4.1) 30 (2.1)	200 (14) 150 (10) 150 (10) 100 (6.9) 60 (4.1) 30 (2.1)	<b>E5SM-3201-22-(* E5SM-3201-33-(* E5SM-3201-34-(* E5SM-3201-44-(* E5SM-3201-64-(* E5SM-3201-84-(*</b>	<b>E5SM-3301-22-(* E5SM-3301-33-(* E5SM-3301-34-(* E5SM-3301-44-(* E5SM-3301-64-(* E5SM-3301-84-(*</b>	1/32" (0.8 mm) 3/64" (1.2 mm) 3/64" (1.2 mm) 1/16" (1.6 mm) 3/32" (2.4 mm) 1/8" (3.2 mm)	1/32" (0.8 mm) 3/64" (1.2 mm) 1/16" (1.6 mm) 1/16" (1.6 mm) 1/16" (1.6 mm) 1/16" (1.6 mm)	
<b>THREE-WAY 3/2 NORMALLY CLOSED (PIPED EX- HAUST)</b> Air, Oil or Water	200 (14) 150 (10) 150 (10) 100 (6.9) 60 (4.1) 30 (2.1)	200 (14) 150 (10) 150 (10) 100 (6.9) 60 (4.1) 30 (2.1)	<b>E5SM-3201-22-H2-(* E5SM-3201-33-H2-(* E5SM-3201-34-H2-(* E5SM-3201-44-H2-(* E5SM-3201-64-H2-(* E5SM-3201-84-H2-(*</b>	<b>E5SM-3301-22-H2-(* E5SM-3301-33-H2-(* E5SM-3301-34-H2-(* E5SM-3301-44-H2-(* E5SM-3301-64-H2-(* E5SM-3301-84-H2-(*</b>	1/32" (0.8 mm) 3/64" (1.2 mm) 3/64" (1.2 mm) 1/16" (1.6 mm) 3/32" (2.4 mm) 1/8" (3.2 mm)	1/32" (0.8 mm) 3/64" (1.2 mm) 1/16" (1.6 mm) 1/16" (1.6 mm) 1/16" (1.6 mm) 1/16" (1.6 mm)	
<b>THREE-WAY 3/2 NORMALLY OPEN</b> Air, Oil or Water	150 (10) 125 (8.6) 100 (6.9) 75 (5.2)	150 (10) 125 (8.6) 75 (5.2) 45 (3.1)	<b>E5SM-3202-22-H2-(* E5SM-3202-33-H2-(* E5SM-3202-44-H2-(* E5SM-3202-64-H2-(*</b>	<b>E5SM-3302-22-H2-(* E5SM-3302-33-H2-(* E5SM-3302-44-H2-(* E5SM-3302-64-H2-(*</b>	1/32" (0.8 mm) 3/64" (1.2 mm) 1/16" (1.6 mm) 3/32" (2.4 mm)	1/32" (0.8 mm) 3/64" (1.2 mm) 1/16" (1.6 mm) 1/16" (1.6 mm)	
<b>THREE-WAY 3/2 DIRECTIONAL CONTROL</b> Air, Oil or Water	300 (21) 200 (14) 100 (6.9) 75 (5.2)	200 (14) 100 (6.9) 50 (3.4) 25 (1.7)	<b>E5SM-7202-22-H2-(* E5SM-7202-33-H2-(* E5SM-7202-44-H2-(* E5SM-7202-64-H2-(*</b>	<b>E5SM-7302-22-H2-(* E5SM-7302-33-H2-(* E5SM-7302-44-H2-(* E5SM-7302-64-H2-(*</b>	1/32" (0.8 mm) 3/64" (1.2 mm) 1/16" (1.6 mm) 3/32" (2.4 mm)	1/32" (0.8 mm) 3/64" (1.2 mm) 1/16" (1.6 mm) 1/16" (1.6 mm)	
<b>THREE-WAY 3/2 MULTI- PURPOSE</b> Air, Oil or Water	125 (8.6) 100 (6.9) 65 (4.5)	125 (8.6) 100 (6.9) 50 (3.4)	<b>E5SM-8202-22-H2-(* E5SM-8202-33-H2-(* E5SM-8202-44-H2-(*</b>	<b>E5SM-8302-22-H2-(* E5SM-8302-33-H2-(* E5SM-8302-44-H2-(*</b>	1/32" (0.8 mm) 3/64" (1.2 mm) 1/16" (1.6 mm)	1/32" (0.8 mm) 3/64" (1.2 mm) 1/16" (1.6 mm)	

### NOTES:

- \*Specify Voltage: See "Coil Code" definition page 7.
- For General Purpose coil voltages see page 4.
- For Hazardous Location coil voltages see page 7.

Standard Wattage	Product Number (For Coil Voltages See Page 7)	Maximum Operating Pressure Differential psi (bar)†	HAZARDOUS LOCATION VALVES (For Coil Voltages See Page 7)			
			Recommended Product Numbers			
			1/8" BODY PORTS		1/4" BODY PORTS	
			AC or DC	1.8 Watt	0.85 Watt	1.8 Watt
	E5SM-2201-20-XX-(*) E5SM-2201-30-XX-(*) E5SM-2201-40-XX-(*) E5SM-2201-60-XX-(*) E5SM-2201-80-XX-(*)	120 (8.3) 80 (5.5) 50 (3.4)	E5SM-2201-20-LB-XX-(*) E5SM-2201-30-LB-XX-(*) E5SM-2201-40-LB-XX-(*)	E5SM-2201-20-LA-XX-(*) (DC Voltage Only)	E5SM-2301-20-LB-XX-(*) E5SM-2301-30-LB-XX-(*) E5SM-2301-40-LB-XX-(*)	E5SM-2301-20-LA-XX-(*) (DC Voltage Only)
	E5SM-2202-02-H2-XX-(*) E5SM-2202-03-H2-XX-(*) E5SM-2202-04-H2-XX-(*)	200 (13.8) 120 (8.3) 50 (3.4)	E5SM-2202-02-H2-LB-XX-(*) E5SM-2202-03-H2-LB-XX-(*) E5SM-2202-04-H2-LB-XX-(*)	—	E5SM-2302-02-H2-LB-XX-(*) E5SM-2302-03-H2-LB-XX-(*) E5SM-2302-04-H2-LB-XX-(*)	—
	E5SM-3201-22-XX-(*) E5SM-3201-33-XX-(*) E5SM-3201-34-XX-(*) E5SM-3201-44-XX-(*) E5SM-3201-64-XX-(*) E5SM-3201-84-XX-(*)	120 (8.3) 60 (4.1) 30 (2.1)	E5SM-3201-23-LB-XX-(*) E5SM-3201-33-LB-XX-(*) E5SM-3201-44-LB-XX-(*)	E5SM-3201-22-LA-XX-(*) (DC Voltage Only)	E5SM-3301-23-LB-XX-(*) E5SM-3301-33-LB-XX-(*) E5SM-3301-44-LB-XX-(*)	E5SM-3301-22-LA-XX-(*) (DC Voltage Only)
	E5SM-3201-22-H2-XX-(*) E5SM-3201-33-H2-XX-(*) E5SM-3201-34-H2-XX-(*) E5SM-3201-44-H2-XX-(*) E5SM-3201-64-H2-XX-(*) E5SM-3201-84-H2-XX-(*)	120 (8.3) 60 (4.1) 30 (2.1)	E5SM-3201-23-H2-LB-XX-(*) E5SM-3201-33-H2-LB-XX-(*) E5SM-3201-44-H2-LB-XX-(*)	E5SM-3201-22-H2-LB-XX-(*) (DC Voltage Only)	E5SM-3301-23-H2-LB-XX-(*) E5SM-3301-33-H2-LB-XX-(*) E5SM-3301-44-H2-LB-XX-(*)	E5SM-3301-22-H2-LB-XX-(*) (DC Voltage Only)
	E5SM-3202-22-H2-XX-(*) E5SM-3202-33-H2-XX-(*) E5SM-3202-44-H2-XX-(*) E5SM-3202-64-H2-XX-(*)					
	E5SM-7202-22-H2-XX-(*) E5SM-7202-33-H2-XX-(*) E5SM-7202-44-H2-XX-(*) E5SM-7202-64-H2-XX-(*)		<b>1/8" Body 1/2" NPT Conduit Connector (-XX Type)</b>		<b>1/4" Body M20" Conduit Connector (-XN Type)</b>	
	E5SM-8202-22-H2-XX-(*) E5SM-8202-33-H2-XX-(*) E5SM-8202-44-H2-XX-(*)					

†60 psi maximum pressure for 1.8 Watt in hydraulic applications. 0.85 Watt pneumatic only.

For higher pressures and temperature see E4 on page 14

Orifice/Cv		
Code	Orifice	Cv
2	1/32"	0.022
3	3/64"	0.06
4	1/16"	0.11
6	3/32"	0.21
8	1/8"	0.26
10	5/32"	0.45
12	3/16"	0.56
16	1/4"	0.79

# SERIES E4

## XV & XT World Solenoid Valves

A compact, heavy duty solenoid valve for hazardous location service. Valve and solenoid housing are stainless steel for superior corrosion resistance. Worldwide certifications available. Valves available in 2-Way, 3-Way, selector or diverter functions. All products are rated for air, gas, oil or water. Porting available in 1/8" or 1/4" NPT for tubing convenience.

Function:	2-Way NC, 2-Way NO, 3-Way NC, 3-Way NO, Directional & Multi-Purpose
Pressure:	to 400 psi (see selector table)
Media	Air, Oil, Water
Flow:	to 0.26 Cv (see selector table)
Temperature:	+5°F to 194°F (-15°C to 90°C) -40°F to 194°F (-40°C to 90°C)(low temp option -44)
Ports, Inlet & Outlet:	1/8" or 1/4" NPT
Exhaust/vent:	Vent to atmosphere, #10-32 thread (NPT port or dust protectors available)
Voltages:	AC or DC (see page 7)
Coil rating:	Class H, continuous duty
Power:	1.8 or 0.85 watt
Connections:	1/2" NPT
Ingress protection:	IP 66/67/68 NEMA 4X, 6P
Materials of construction:	
Body:	430 Stainless (316 Stainless Steel optional)
Seals	FKM-fluorocarbon (Low Temp Nitrile optional)
Coil:	Epoxy molded
Mounting:	(2) threaded holes (optional bracket -WMA)



XV solenoid shown with H2E Hyd adapter



XT solenoid shown with D14 Dust Nut

	XV	-XT
CSA North American	CI I, DIV I Grp B, C, D CI II, DIV I, Grp E, F, G CI I, DIV II, Grp A, B, C, D CI II, DIV I, Grp E, F, G CI III	CL, I, Zn 1 A/Ex de IIC T CL, II Zn, 21 AEx tDA21, DIP A21
ATEX	—	II 2 GD Ex d e IIC T4 Gb Ex tb IIIC IP66 T4C Db
IECEX	—	Ex d e IIC T4 Gb Ex tb IIIC IP66 T4C Db
INMETRO	—	Ex d e IIC T4 Gb Ex tb IIIC IP66 T4C Db
Russia, Kazakhstan and Belarus	—	Ex d e IIC T4 Gb Ex tb IIIC IP66 T4 Db



Stainless steel coil housing	Popular Options Packages			
	Solenoid Ordering Code 1.8 Watt		Solenoid Ordering Code 0.85 Watt	
	North American	World	North American	World
Standard (vent to atmosphere)	-XV1	-XT1	-XV1C	-XT1C
1/8" Adapter (-H2E)	-XV2	-XT2	-XV2C	-XT2C
1/4" Adapter (-HE)	-XV3	-XT3	-XV3C	-XT3C
Dust Nut (-L14)	-XV4	-XT4	-XV4C	-XT4C
Dust Nut (-D14)	<b>-XV9</b>	<b>-XT9</b>	<b>-XV9C</b>	<b>-XT9C</b>

\*Bold, recommended solenoid options. See page 5 for additional options.

### Options - Suffix Details



Orifice/Cv		
Code	Orifice	Cv
2	1/32"	0.022
3	3/64"	0.06
4	1/16"	0.11
6	3/32"	0.21

1.8 Watt Product Selector	Maximum Differential/ Operating Pressure psi (bar)	Orifice/Flow				Product Number For Pneumatic and Hydraulic Service	
		"A" to "B"		"B" to "C"		1/8" NPT	1/4" NPT
		In (mm)	Cv	In (mm)	Cv		
TWO-WAY 2/2 NORMALLY CLOSED	400 (27.6)	1/32" (0.8 mm)	0.022			E4SM-2201-20-X**-(*)	E4SM-2301-20-X**-(*)
	300 (20.7)	3/64" (1.2 mm)	0.06			E4SM-2201-30-X**-(*)	E4SM-2301-30-X**-(*)
	200 (13.8)	1/16" (1.6 mm)	0.11			E4SM-2201-40-X**-(*)	E4SM-2301-40-X**-(*)
	100 (6.9)	3/32" (2.4 mm)	0.21			E4SM-2201-60-X**-(*)	E4SM-2301-60-X**-(*)
	50 (3.4)	1/8" (3.2 mm)	0.26			E4SM-2201-80-X**-(*)	E4SM-2301-80-X**-(*)
TWO-WAY 2/2 NORMALLY OPEN	300 (20.7)			1/32" (0.8 mm)	0.022	E4SM-2202-02-X**-(*)	E4SM-2302-02-X**-(*)
	150 (10.3)			3/64" (1.2 mm)	0.06	E4SM-2202-03-X**-(*)	E4SM-2302-03-X**-(*)
	100 (6.9)			1/16" (1.6 mm)	0.11	E4SM-2202-04-X**-(*)	E4SM-2302-04-X**-(*)
	50 (3.4)			3/32" (2.4 mm)	0.21	E4SM-2202-06-X**-(*)	E4SM-2302-06-X**-(*)
THREE-WAY 3/2 NORMALLY CLOSED (Exhaust to atm)	200 (13.8)	1/32" (0.8 mm)	0.022	3/64" (1.2 mm)	0.06	E4SM-3201-23-X**-(*)	E4SM-3301-23-X**-(*)
	175 (12.1)	3/64" (1.2 mm)	0.06	1/16" (1.6 mm)	0.11	E4SM-3201-34-X**-(*)	E4SM-3301-34-X**-(*)
	125 (8.6)	1/16" (1.6 mm)	0.11	1/16" (1.6 mm)	0.11	E4SM-3201-44-X**-(*)	E4SM-3301-44-X**-(*)
	75 (5.2)	3/32" (2.4 mm)	0.21	1/16" (1.6 mm)	0.11	E4SM-3201-64-X**-(*)	E4SM-3301-64-X**-(*)
THREE-WAY 3/2 NORMALLY CLOSED (Piped exhaust)	200 (13.8)	1/32" (0.8 mm)	0.022	3/64" (1.2 mm)	0.06	E4SM-3201-23-X**-(*)	E4SM-3301-23-X**-(*)
	175 (12.1)	3/64" (1.2 mm)	0.06	1/16" (1.6 mm)	0.11	E4SM-3201-34-X**-(*)	E4SM-3301-34-X**-(*)
	125 (8.6)	1/16" (1.6 mm)	0.11	1/16" (1.6 mm)	0.11	E4SM-3201-44-X**-(*)	E4SM-3301-44-X**-(*)
	75 (5.2)	3/32" (2.4 mm)	0.21	1/16" (1.6 mm)	0.11	E4SM-3201-64-X**-(*)	E4SM-3301-64-X**-(*)
THREE-WAY 3/2 NORMALLY OPEN	150 (10.3)	1/32" (0.8 mm)	.022	1/32" (0.8 mm)	.022	E4SM-3202-22-X**-(*)	E4SM-3302-22-X**-(*)
	100 (6.9)	3/64" (1.2 mm)	0.06	3/64" (1.2 mm)	0.06	E4SM-3202-33-X**-(*)	E4SM-3302-33-X**-(*)
	75 (5.2)	1/16" (1.6 mm)	0.11	1/16" (1.6 mm)	0.11	E4SM-3202-44-X**-(*)	E4SM-3302-44-X**-(*)
	50 (3.4)	3/32" (2.4 mm)	0.21	1/16" (1.6 mm)	0.11	E4SM-3202-64-X**-(*)	E4SM-3302-64-X**-(*)
THREE-WAY 3/2 DIRECTIONAL CONTROL	250 (17.2)	1/32" (0.8 mm)	.022	1/32" (0.8 mm)	0.022	E4SM-7202-22-X**-(*)	E4SM-7302-22-X**-(*)
	200 (13.8)	3/64" (1.2 mm)	0.06	3/64" (1.2 mm)	0.06	E4SM-7202-33-X**-(*)	E4SM-7302-33-X**-(*)
	150 (10.3)	1/16" (1.6 mm)	0.11	1/16" (1.6 mm)	0.11	E4SM-7202-44-X**-(*)	E4SM-7302-44-X**-(*)
	120 (8.3)	3/32" (2.4 mm)	0.21	1/16" (1.6 mm)	0.11	E4SM-7202-64-X**-(*)	E4SM-7302-64-X**-(*)
THREE-WAY 3/2 MULTI-PURPOSE	150 (10.3)	1/32" (0.8 mm)	.022	1/32" (0.8 mm)	0.022	E4SM-8202-22-X**-(*)	E4SM-8302-22-X**-(*)
	75 (5.2)	3/64" (1.2 mm)	0.06	3/64" (1.2 mm)	0.06	E4SM-8202-33-X**-(*)	E4SM-8302-33-X**-(*)
	60 (4.1)	1/16" (1.6 mm)	0.11	1/16" (1.6 mm)	0.11	E4SM-8202-44-X**-(*)	E4SM-8302-44-X**-(*)
	30 (2.1)	3/32" (2.4 mm)	0.21	1/16" (1.6 mm)	0.11	E4SM-8202-64-X**-(*)	E4SM-8302-64-X**-(*)

\*Voltages 1.8 watt: AC 120/60 (-A120), 110/50 (-E110), 240/60 (-A240), 220/50 (-E220); 12 vdc (-D012), DC 24 vdc (-D024), 48 vdc (-D048), 110 vdc (-D110), 220 vdc (D220)

\*\*Solenoid Options: Select options from "Solenoid Ordering Code 1.8 Watt" page 14. e.g.: E4SM-3201-23-XV2-Voltage

0.85 Watt Product Selector	Maximum Differential/ Operating Pressure psi (bar)	Orifice/Flow				Product Number For Pneumatic and Hydraulic Service	
		"A" to "B"		"B" to "C"		1/8" NPT	1/4" NPT
		In (mm)	Cv	In (mm)	Cv		
TWO-WAY 2/2 NORMALLY CLOSED	250 (17.2)	1/32" (0.8 mm)	0.022			E4SM-2201-20-X***-(*)	E4SM-2301-20-X***-(*)
	150 (10.3)	3/64" (1.2 mm)	0.06			E4SM-2201-30-X***-(*)	E4SM-2301-30-X***-(*)
	80 (5.5)	1/16" (1.6 mm)	0.11			E4SM-2201-40-X***-(*)	E4SM-2301-40-X***-(*)
TWO-WAY 2/2 NORMALLY OPEN	175 (12.1)			1/32" (0.8 mm)	0.022	E4SM-2302-02-X***-(*)	E4SM-2302-02-X***-(*)
	100 (6.9)			3/64" (1.2 mm)	0.06	E4SM-2302-03-X***-(*)	E4SM-2302-03-X***-(*)
THREE-WAY 3/2 NORMALLY CLOSED (Exhaust to atm)	150 (10.3)	1/32" (0.8 mm)	0.022	3/64" (1.2 mm)	0.06	E4SM-3201-23-X***-(*)	E4SM-3301-23-X***-(*)
	125 (8.6)	3/64" (1.2 mm)	0.06	3/64" (1.2 mm)	0.06	E4SM-3201-33-X***-(*)	E4SM-3301-33-X***-(*)
	100 (6.9)	3/64" (1.2 mm)	0.06	1/16" (1.6 mm)	0.11	E4SM-3201-34-X***-(*)	E4SM-3301-34-X***-(*)
	75 (5.2)	1/16" (1.6 mm)	0.11	1/16" (1.6 mm)	0.11	E4SM-3201-44-X***-(*)	E4SM-3301-44-X***-(*)
	50 (3.4)	3/32" (2.4 mm)	0.21	1/16" (1.6 mm)	0.11	E4SM-3201-64-X***-(*)	E4SM-3301-64-X***-(*)
	25 (1.7)	3/32" (2.4 mm)	0.21	3/32" (2.4 mm)	0.21	E4SM-3201-66-X***-(*)	E4SM-3301-66-X***-(*)
THREE-WAY 3/2 NORMALLY CLOSED (Piped exhaust)	150 (10.3)	1/32" (0.8 mm)	0.022	3/64" (1.2 mm)	0.06	E4SM-3201-23-X***-(*)	E4SM-3301-23-X***-(*)
	125 (8.6)	3/64" (1.2 mm)	0.06	3/64" (1.2 mm)	0.06	E4SM-3201-33-X***-(*)	E4SM-3301-33-X***-(*)
	100 (6.9)	3/64" (1.2 mm)	0.06	1/16" (1.6 mm)	0.11	E4SM-3201-34-X***-(*)	E4SM-3301-34-X***-(*)
	75 (5.2)	1/16" (1.6 mm)	0.11	1/16" (1.6 mm)	0.11	E4SM-3201-44-X***-(*)	E4SM-3301-44-X***-(*)
	50 (3.4)	3/32" (2.4 mm)	0.21	1/16" (1.6 mm)	0.11	E4SM-3201-64-X***-(*)	E4SM-3301-64-X***-(*)
	25 (1.7)	3/32" (2.4 mm)	0.21	3/32" (2.4 mm)	0.21	E4SM-3201-66-X***-(*)	E4SM-3301-66-X***-(*)
THREE-WAY 3/2 NORMALLY OPEN	125 (8.6)	1/32" (0.8 mm)	0.022	1/32" (0.8 mm)	0.022	E4SM-3202-22-X***-(*)	E4SM-3302-22-X***-(*)
	100 (6.9)	3/64" (1.2 mm)	0.06	3/64" (1.2 mm)	0.06	E4SM-3202-33-X***-(*)	E4SM-3302-33-X***-(*)
	60 (4.1)	1/16" (1.6 mm)	0.11	1/16" (1.6 mm)	0.11	E4SM-3202-44-X***-(*)	E4SM-3302-44-X***-(*)
THREE-WAY 3/2 DIRECTIONAL CONTROL	110 (7.6)	1/32" (0.8 mm)	0.022	1/32" (0.8 mm)	0.22	E4SM-7202-22-X***-(*)	E4SM-7302-22-X***-(*)
	100 (6.9)	3/64" (1.2 mm)	0.06	3/64" (1.2 mm)	0.06	E4SM-7202-33-X***-(*)	E4SM-7302-33-X***-(*)
	80 (5.5)	1/16" (1.6 mm)	0.11	1/16" (1.6 mm)	0.11	E4SM-7202-44-X***-(*)	E4SM-7302-44-X***-(*)
THREE-WAY 3/2 MULTI-PURPOSE	125 (8.6)	1/32" (0.8 mm)	0.022	1/32" (0.8 mm)	0.022	E4SM-8202-22-X***-(*)	E4SM-8302-22-X***-(*)
	100 (6.9)	3/64" (1.2 mm)	0.06	3/64" (1.2 mm)	0.06	E4SM-8202-33-X***-(*)	E4SM-8302-33-X***-(*)
	40 (2.8)	1/16" (1.6 mm)	0.11	1/16" (1.6 mm)	0.11	E4SM-8202-44-X***-(*)	E4SM-8302-44-X***-(*)

\*Voltages 0.85 Watt: 12 vdc (-D012), 24 vdc (-D024), 48 vdc (-D048)

\*\*\*Solenoid Options: Select options from "Solenoid Ordering Code 0.85 Watt" page 14. e.g.: E4SM-3201-23-XT2C-Voltage

# SERIES E4

## XDB World Solenoid Valve

A compact, heavy duty solenoid valve with integral junction box for hazardous location service. Valve and junction box are stainless steel for superior corrosion resistance. Worldwide certifications available. Valves available in 2-Way, 3-Way, selectors or diverters functions. All products are rated for air, gas, oil or water. Porting available in 1/8" or 1/4" NPT for tubing convenience.

Function:	2-Way NC, 2-Way NO, 3-Way NC, 3-Way NO, Directional & Multi-Purpose
Pressure:	to 400 psi (see selector table)
Media	Air, Oil, Water
Flow:	to 0.26 Cv (see selector table)
Temperature:	+5°F to 194°F (-15°C to 90°C) -40°F to 194°F (-40°C to 90°C)(low temp option -44)
Ports, Inlet & Outlet:	1/8" or 1/4" NPT
Exhaust/vent:	Vent to atmosphere, #10-32 thread (NPT port or dust protectors available)
Voltages:	AC or DC (see page 7)
Coil rating:	Class H, continuous duty
Power:	1.8 or 0.85 watt
Connections:	1/2" NPT or M20 conduit hub
Ingress protection:	IP 66/67/68 NEMA 4X, 6P
Materials of construction:	
Body:	430 Stainless (316 Stainless Steel optional)
Seals	FKM-fluorocarbon (Low Temp Nitrile optional)
Coil:	Epoxy molded
Mounting:	(2) threaded holes (optional bracket -WMA)



Shown with Dust Nut and Mounting Bracket



	-XDBS M20 x 1,5	XDBT 1/2" NPT
CSA North American	NA	CI I, DIV I Grp B, C, D CI II, DIV I, Grp E, F, G CI I, DIV II, Grp A, B, C, D CI II, DIV I, Grp E, F, G CI III
ATEX	II 2 GD Ex d e IIC T4 Gb Ex tb IIIC IP66 T4C Db	II 2 GD Ex d e IIC T4 Gb Ex tb IIIC IP66 T4C Db
IECEx	Ex d e IIC T4 Gb Ex tb IIIC IP66 T4C Db	Ex d e IIC T4 Gb Ex tb IIIC IP66 T4C Db
INMETRO	Ex d e IIC T4 Gb Ex tb IIIC IP66 T4C Db	Ex d e IIC T4 Gb Ex tb IIIC IP66 T4C Db
Russia, Kazakhstan and Belarus	Ex d e IIC T4 Gb Ex tb IIIC IP66 T4 Db	Ex d e IIC T4 Gb Ex tb IIIC IP66 T4 Db

Stainless steel coil housing with internal Junction Box. Internal and external ground screw.	Popular Options Packages			
	Suffix Detail Ordering Code*			
	M 20 Connection		1/2" Connection	
	No Diode	Diode	No Diode	Diode
Standard (vent to atmosphere)	-XDBS1	-XDBS5	-XDBT1	-XDBT5
1/8" Adapter (-H2E)	-XDBS2	-XDBS6	-XDBT2	-XDBT6
1/4" Adapter (-HE)	-XDBS3	-XDBS7	-XDBT3	-XDBT7
Dust Nut (-L14)	-XDBS4	-XDBS8	-XDBT4	-XDBT8
Dust Nut (-D14)	<b>-XDBS9</b>	-XDBS10	<b>-XDBT9</b>	-XDBT10

\*Suffix Details above are for 1.8 watt coils. For 0.85 watt coils add a "C" as last character to above. Example: XDBS1C. Also see "Product Number" tables opposite page for valve part number.

\*Bold, recommended solenoid options. See page 5 for additional options.

### Options - Suffix Details



Orifice/Cv		
Code	Orifice	Cv
2	1/32"	0.022
3	3/64"	0.06
4	1/16"	0.11
6	3/32"	0.21



1.8 Watt Product Selector		Maximum Differential/ Operating Pressure psi (bar)	Orifice/Flow				Product Number For Pneumatic and Hydraulic Service	
			"A" to "B"		"B" to "C"		1/8" NPT	1/4" NPT
			In (mm)	Cv	In (mm)	Cv		
TYPE Media								
TWO-WAY 2/2 NORMALLY CLOSED	400 (27.6)	1/32" (0.8 mm)	0.022			E4SM-2201-20-XDB**-(*)	E4SM-2301-20-XDB**-(*)	
	300 (20.7)	3/64" (1.2 mm)	0.06			E4SM-2201-30-XDB**-(*)	E4SM-2301-30-XDB**-(*)	
	200 (13.8)	1/16" (1.6 mm)	0.11			E4SM-2201-40-XDB**-(*)	E4SM-2301-40-XDB**-(*)	
	100 (6.9)	3/32" (2.4 mm)	0.21			E4SM-2201-60-XDB**-(*)	E4SM-2301-60-XDB**-(*)	
	50 (3.4)	1/8" (3.2 mm)	0.26			E4SM-2201-80-XDB**-(*)	E4SM-2301-80-XDB**-(*)	
TWO-WAY 2/2 NORMALLY OPEN	300 (20.7)			1/32" (0.8 mm)	0.022	E4SM-2202-02-XDB**-(*)	E4SM-2302-02-XDB**-(*)	
	150 (10.3)			3/64" (1.2 mm)	0.06	E4SM-2202-03-XDB**-(*)	E4SM-2302-03-XDB**-(*)	
	100 (6.9)			1/16" (1.6 mm)	0.11	E4SM-2202-04-XDB**-(*)	E4SM-2302-04-XDB**-(*)	
	50 (3.4)			3/32" (2.4 mm)	0.21	E4SM-2202-06-XDB**-(*)	E4SM-2302-06-XDB**-(*)	
THREE-WAY 3/2 NORMALLY CLOSED (Exhaust to atm)	200 (13.8)	1/32" (0.8 mm)	0.022	3/64" (1.2 mm)	0.06	E4SM-3201-23-XDB**-(*)	E4SM-3301-23-XDB**-(*)	
	175 (12.1)	3/64" (1.2 mm)	0.06	1/16" (1.6 mm)	0.11	E4SM-3201-34-XDB**-(*)	E4SM-3301-34-XDB**-(*)	
	125 (8.6)	1/16" (1.6 mm)	0.11	1/16" (1.6 mm)	0.11	E4SM-3201-44-XDB**-(*)	E4SM-3301-44-XDB**-(*)	
	75 (5.2)	3/32" (2.4 mm)	0.21	1/16" (1.6 mm)	0.11	E4SM-3201-64-XDB**-(*)	E4SM-3301-64-XDB**-(*)	
THREE-WAY 3/2 NORMALLY CLOSED (Piped exhaust)	200 (13.8)	1/32" (0.8 mm)	0.022	3/64" (1.2 mm)	0.06	E4SM-3201-23-XDB**-(*)	E4SM-3301-23-XDB**-(*)	
	175 (12.1)	3/64" (1.2 mm)	0.06	1/16" (1.6 mm)	0.11	E4SM-3201-34-XDB**-(*)	E4SM-3301-34-XDB**-(*)	
	125 (8.6)	1/16" (1.6 mm)	0.11	1/16" (1.6 mm)	0.11	E4SM-3201-44-XDB**-(*)	E4SM-3301-44-XDB**-(*)	
	75 (5.2)	3/32" (2.4 mm)	0.21	1/16" (1.6 mm)	0.11	E4SM-3201-64-XDB**-(*)	E4SM-3301-64-XDB**-(*)	
THREE-WAY 3/2 NORMALLY OPEN	150 (10.3)	1/32" (0.8 mm)	.022	1/32" (0.8 mm)	.022	E4SM-3202-22-XDB**-(*)	E4SM-3302-22-XDB**-(*)	
	100 (6.9)	3/64" (1.2 mm)	0.06	3/64" (1.2 mm)	0.06	E4SM-3202-33-XDB**-(*)	E4SM-3302-33-XDB**-(*)	
	75 (5.2)	1/16" (1.6 mm)	0.11	1/16" (1.6 mm)	0.11	E4SM-3202-44-XDB**-(*)	E4SM-3302-44-XDB**-(*)	
	50 (3.4)	3/32" (2.4 mm)	0.21	1/16" (1.6 mm)	0.11	E4SM-3202-64-XDB**-(*)	E4SM-3302-64-XDB**-(*)	
THREE-WAY 3/2 DIRECTIONAL CONTROL	250 (17.2)	1/32" (0.8 mm)	.022	1/32" (0.8 mm)	0.022	E4SM-7202-22-XDB**-(*)	E4SM-7302-22-XDB**-(*)	
	200 (13.8)	3/64" (1.2 mm)	0.06	3/64" (1.2 mm)	0.06	E4SM-7202-33-XDB**-(*)	E4SM-7302-33-XDB**-(*)	
	150 (10.3)	1/16" (1.6 mm)	0.11	1/16" (1.6 mm)	0.11	E4SM-7202-44-XDB**-(*)	E4SM-7302-44-XDB**-(*)	
	120 (8.3)	3/32" (2.4 mm)	0.21	1/16" (1.6 mm)	0.11	E4SM-7202-64-XDB**-(*)	E4SM-7302-64-XDB**-(*)	
THREE-WAY 3/2 MULTI-PURPOSE	150 (10.3)	1/32" (0.8 mm)	.022	1/32" (0.8 mm)	0.022	E4SM-8202-22-XDB**-(*)	E4SM-8302-22-XDB**-(*)	
	75 (5.2)	3/64" (1.2 mm)	0.06	3/64" (1.2 mm)	0.06	E4SM-8202-33-XDB**-(*)	E4SM-8302-33-XDB**-(*)	
	60 (4.1)	1/16" (1.6 mm)	0.11	1/16" (1.6 mm)	0.11	E4SM-8202-44-XDB**-(*)	E4SM-8302-44-XDB**-(*)	
	30 (2.1)	3/32" (2.4 mm)	0.21	1/16" (1.6 mm)	0.11	E4SM-8202-64-XDB**-(*)	E4SM-8302-64-XDB**-(*)	

\*Voltages: AC 120/60 (-A120), 110/50 (-E110), 240/60 (-A240), 220/50 (-E220) DC 24 vdc (-D024), 48 vdc (-D048), 12 vdc (-D012), 110 vdc (-D110), 220 vdc (D220)

\*\*Product Number. Complete product number by inserting one of the following in place of the \*\*: S1 = M20 conduit connection, no diode, T1 = 1/2" npt conduit connection no diode, S5 = M20 conduit connection with diode, T5 = 1/2" npt conduit connection with diode.

0.85 Watt Product Selector		Maximum Differential/ Operating Pressure psi (bar)	Orifice/Flow				Product Number For Pneumatic and Hydraulic Service	
			"A" to "B"		"B" to "C"		1/8" NPT	1/4" NPT
			In (mm)	Cv	In (mm)	Cv		
TYPE Media								
TWO-WAY 2/2 NORMALLY CLOSED	250 (17.2)	1/32" (0.8 mm)	0.022			E4SM-2201-20-XDB***(*)	E4SM-2301-20-XDB***(*)	
	150 (10.3)	3/64" (1.2 mm)	0.06			E4SM-2201-30-XDB***(*)	E4SM-2301-30-XDB***(*)	
	80 (5.5)	1/16" (1.6 mm)	0.11			E4SM-2201-40-XDB***(*)	E4SM-2301-40-XDB***(*)	
TWO-WAY 2/2 NORMALLY OPEN	175 (12.1)			1/32" (0.8 mm)	0.022	E4SM-2302-02-XDB***(*)	E4SM-2302-02-XDB***(*)	
	100 (6.9)			3/64" (1.2 mm)	0.06	E4SM-2302-03-XDB***(*)	E4SM-2302-03-XDB***(*)	
THREE-WAY 3/2 NORMALLY CLOSED (Exhaust to atm)	150 (10.3)	1/32" (0.8 mm)	0.022	3/64" (1.2 mm)	0.06	E4SM-3201-23-XDB***(*)	E4SM-3301-23-XDB***(*)	
	125 (8.6)	3/64" (1.2 mm)	0.06	3/64" (1.2 mm)	0.06	E4SM-3201-33-XDB***(*)	E4SM-3301-33-XDB***(*)	
	100 (6.9)	3/64" (1.2 mm)	0.06	1/16" (1.6 mm)	0.11	E4SM-3201-34-XDB***(*)	E4SM-3301-34-XDB***(*)	
	75 (5.2)	1/16" (1.6 mm)	0.11	1/16" (1.6 mm)/	0.11	E4SM-3201-44-XDB***(*)	E4SM-3301-44-XDB***(*)	
	50 (2.8)	3/32" (2.4 mm)	0.21	1/16" (1.6 mm)	0.11	E4SM-3201-64-XDB***(*)	E4SM-3301-64-XDB***(*)	
25 (1.7)	3/32" (2.4 mm)	0.21	3/32" (2.4 mm)	0.21	E4SM-3201-66-XDB***(*)	E4SM-3301-66-XDB***(*)		
THREE-WAY 3/2 NORMALLY CLOSED (Piped exhaust)	150 (10.3)	1/32" (0.8 mm)	0.022	3/64" (1.2 mm)	0.06	E4SM-3201-23-XDB***(*)	E4SM-3301-23-XDB***(*)	
	125 (8.6)	3/64" (1.2 mm)	0.06	3/64" (1.2 mm)	0.06	E4SM-3201-33-XDB***(*)	E4SM-3301-33-XDB***(*)	
	100 (6.9)	3/64" (1.2 mm)	0.06	1/16" (1.6 mm)/	0.11	E4SM-3201-34-XDB***(*)	E4SM-3301-34-XDB***(*)	
	75 (5.2)	1/16" (1.6 mm)	0.11	1/16" (1.6 mm)	0.11	E4SM-3201-44-XDB***(*)	E4SM-3301-44-XDB***(*)	
	50 (2.8)	3/32" (2.4 mm)	0.21	1/16" (1.6 mm)	0.11	E4SM-3201-64-XDB***(*)	E4SM-3301-64-XDB***(*)	
25 (1.7)	3/32" (2.4 mm)	0.21	3/32" (2.4 mm)	0.21	E4SM-3201-66-XDB***(*)	E4SM-3301-66-XDB***(*)		
THREE-WAY 3/2 NORMALLY OPEN	125 (8.6)	1/32" (0.8 mm)	0.022	1/32" (0.8 mm)	0.022	E4SM-3202-22-XDB***(*)	E4SM-3302-22-XDB***(*)	
	100 (6.9)	3/64" (1.2 mm)	0.06	3/64" (1.2 mm)	0.06	E4SM-3202-33-XDB***(*)	E4SM-3302-33-XDB***(*)	
	60 (4.1)	1/16" (1.6 mm)	0.11	1/16" (1.6 mm)	0.11	E4SM-3202-44-XDB***(*)	E4SM-3302-44-XDB***(*)	
THREE-WAY 3/2 DIRECTIONAL CONTROL	110 (7.6)	1/32" (0.8 mm)	0.022	1/32" (0.8 mm)	0.22	E4SM-7202-22-XDB***(*)	E4SM-7302-22-XDB***(*)	
	100 (6.9)	3/64" (1.2 mm)	0.06	3/64" (1.2 mm)	0.06	E4SM-7202-33-XDB***(*)	E4SM-7302-33-XDB***(*)	
	80 (5.5)	1/16" (1.6 mm)	0.11	1/16" (1.6 mm)	0.11	E4SM-7202-44-XDB***(*)	E4SM-7302-44-XDB***(*)	
THREE-WAY 3/2 MULTI-PURPOSE	125 (8.6)	1/32" (0.8 mm)	0.022	1/32" (0.8 mm)	0.022	E4SM-8202-22-XDB***(*)	E4SM-8302-22-XDB***(*)	
	100 (6.9)	3/64" (1.2 mm)	0.06	3/64" (1.2 mm)	0.06	E4SM-8202-33-XDB***(*)	E4SM-8302-33-XDB***(*)	
	40 (2.8)	1/16" (1.6 mm)	0.11	1/16" (1.6 mm)	0.11	E4SM-8202-44-XDB***(*)	E4SM-8302-44-XDB***(*)	

\*Voltages: 24 vdc (-D024), 48 vdc (-D048), 12 vdc (-D012)

\*\*\*Product Number. Complete product number by inserting one of the following in place of the \*\*\*: S1C = M20 conduit connection, no diode, T1C = 1/2" npt conduit connection no diode, S5C = M20 conduit connection with diode, T5C = 1/2" npt conduit connection with diode.

# SERIES E

## Side Ported Types

Series E Full-Size Side-Ported valves are direct solenoid actuated and are individually mounted. 1/8 NPT or 1/4 NPT ports are provided in the valve body.

Function	2-Way NC, 2-Way NO, 3-Way NC, 3-Way NO, Directional & Multi-Purpose.
Pressure:	to 250 psi (see table page 19)
Media:	Air, Oil, Water
Flow:	to 0.26 Cv (see table below)
Temperature:	0°F to 180°F (-18°C to 82°C)
Ports, Inlet & Outlet:	1/8" or 1/4" NPT
Exhaust/vent:	Vent to atmosphere, #10-32 thread (NPT port or dust protectors available)
Voltages:	AC or DC (General Purpose see page 4) (Hazardous Location see page 7)
Coil rating:	Class F, continuous duty (Class H optional)
Power:	7.3 - 12 watt
Connections:	1/2" NPT
Ingress protection:	NEMA 1, 2,3 & 4/4X, General Purpose NEMA 1, 2,3 & 4/4X, Hazardous Location NEMA 7, 9 & 4/4X
Materials of construction:	
Body:	430 Stainless (316 Stainless Steel optional)
Seals	NBR (Nitrile)
Coil:	Epoxy molded
Mounting:	(2) threaded holes (optional bracket -WE)



**HAZARDOUS LOCATIONS**



**ORDINARY LOCATIONS**

### GENERAL PURPOSE (NEMA 1,2,3)

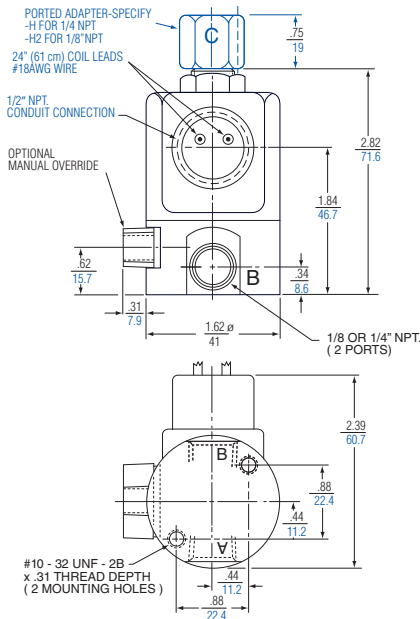

### HAZARDOUS LOCATIONS (NEMA 7&9)

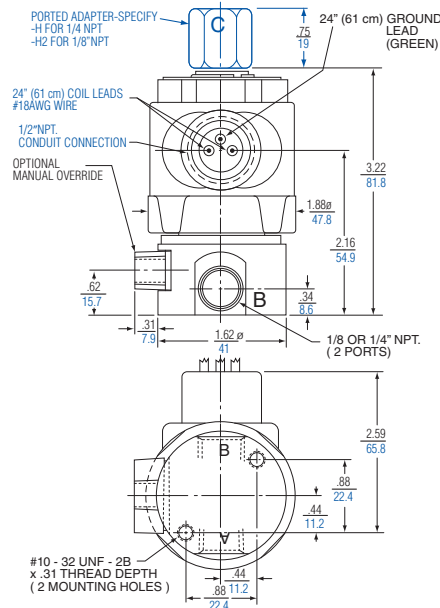

Orifice/Cv		
Code	Orifice	Cv
2	1/32"	0.022
3	3/64"	0.06
4	1/16"	0.11
6	3/32"	0.21
8	1/8"	0.26
10	5/32"	0.45
12	3/16"	0.56
16	1/4"	0.79

DIMENSIONS SHOWN IN INCH  
MM

Color shows piped port C or normally open valve; metric dimensions.

Coil cover shown is supplied as standard and provides housing with threaded boss for conduit connection. Other housing types are available. See page 4.

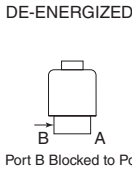
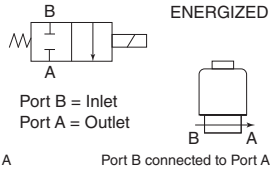
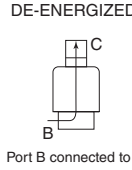
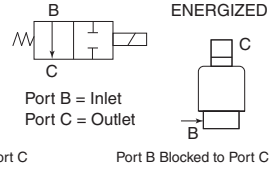
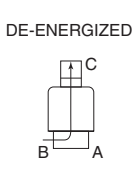
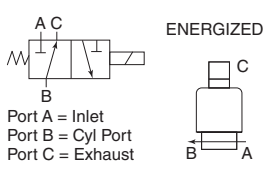
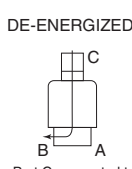
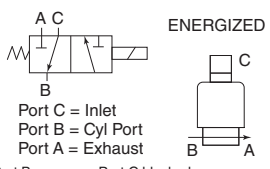
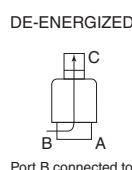
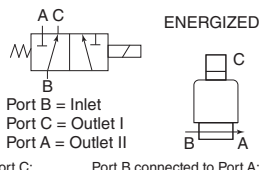
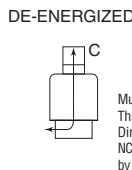
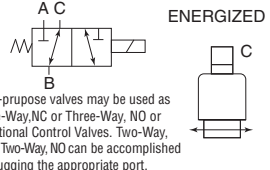
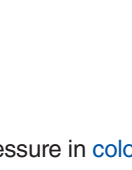
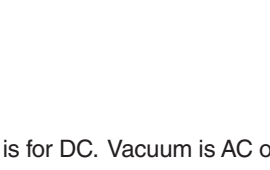
Type	Maximum Operating Pressure Differential psi (bar)†	GENERAL PURPOSE (For Coil Voltages See Page 4)		Min. Orifice between Ports		Piping Arrangement and Flow Pattern
		Product Number with conduit type coil housing. For other housing options see page 4.		"A" - "B"	"B" - "C"	
		1/8" NPT	1/4" NPT			
<b>TWO-WAY 2/2 NORMALLY CLOSED</b> Air, Oil or Water	250 (17) 200 (14) 125 (8.6) 100 (6.9) 75-50 (5.2-3.4) 50-25 (3.4-1.7) 20-5 (1.4-0.3)	ESM-2201-30-(*) ESM-2201-40-(*) ESM-2201-60-(*) ESM-2201-80-(*) ESM-2201-100-(*) ESM-2201-120-(*) ESM-2201-160-(*)	ESM-2301-30-(*) ESM-2301-40-(*) ESM-2301-60-(*) ESM-2301-80-(*) ESM-2301-100-(*) ESM-2301-120-(*) ESM-2301-160-(*)	3/64" (1.2mm) 1/16" (1.6 mm) 3/32" (2.4 mm) 1/8" (3.2mm) 5/32" (4.0 mm) 3/16" (4.8 mm) 1/4" (6.4 mm)		DE-ENERGIZED  ENERGIZED  Port B = Inlet Port A = Outlet Port B Blocked to Port A      Port B connected to Port A
<b>TWO-WAY 2/2 NORMALLY OPEN</b> Air, Oil or Water	200 (14) 150 (10) 125 (8.6)	ESM-2202-03-H2-(*) ESM-2202-04-H2-(*) ESM-2202-06-H2-(*)	ESM-2302-03-H-(*) ESM-2302-04-H-(*) ESM-2302-06-H-(*)		3/64" (1.2 mm) 1/16" (1.6 mm) 3/32" (2.4 mm)	DE-ENERGIZED  ENERGIZED  Port B = Inlet Port C = Outlet Port B connected to Port C      Port B Blocked to Port C
<b>THREE-WAY 3/2 NORMALLY CLOSED (EXHAUST TO ATMOSPHERE)</b> Air Only	150 (10) 100 (6.9) 75 (5.2) 50 (3.4) 20 (1.4) Vac-AC Only	ESM-3201-34-(*) ESM-3201-44-(*) ESM-3201-66-(*) ESM-3201-86-(*) ESM-3201-126-(*) ESM-3201-160-(*)	ESM-3301-34-(*) ESM-3301-44-(*) ESM-3301-66-(*) ESM-3301-86-(*) ESM-3301-126-(*) ESM-3301-166-(*)	3/64" (1.2 mm) 1/16" (1.6 mm) 3/32" (2.4 mm) 1/8" (3.2 mm) 3/16" (4.8 mm) 1/4" (6.4 mm)	1/16" (1.6 mm) 1/16" (1.6 mm) 3/32" (2.4 mm) 3/32" (2.4 mm) 3/32" (2.4 mm) 3/32" (2.4 mm)	DE-ENERGIZED  ENERGIZED  Port A = Inlet Port B = Cyl Port Port C = Exhaust Port A blocked to Port B; Port B connected to Port C      Port A connected to Port B; Port C blocked
<b>THREE-WAY 3/2 NORMALLY CLOSED (PIPED EXHAUST)</b> Air, Oil or Water	150 (10) 100 (6.9) 75 (5.2) 50 (3.4) 20 (1.4) Vac-AC Only	ESM-3201-34-H2-(*) ESM-3201-44-H2-(*) ESM-3201-66-H2-(*) ESM-3201-86-H2-(*) ESM-3201-126-H2(*) ESM-3201-166-H2-(*)	ESM-3301-34-H-(*) ESM-3301-44-H-(*) ESM-3301-66-H-(*) ESM-3301-86-H-(*) ESM-3301-126-H-(*) ESM-3301-166-H-(*)	3/64" (1.2 mm) 1/16" (1.6 mm) 3/32" (2.4 mm) 1/8" (3.2 mm) 3/16" (4.8 mm) 1/4" (6.4 mm)	1/16" (1.6 mm) 1/16" (1.6 mm) 3/32" (2.4 mm) 3/32" (2.4 mm) 3/32" (2.4 mm) 3/32" (2.4 mm)	DE-ENERGIZED  ENERGIZED  Port C = Inlet Port B = Cyl Port Port A = Exhaust Port C connected to Port B; Port A blocked      Port C blocked; Port B connected to Port A
<b>THREE-WAY 3/2 NORMALLY OPEN</b> Air, Oil or Water	150 (10) 100 (6.9) 100 (6.9) 75 (5.2) 75 (5.2)	ESM-3202-43-H2-(*) ESM-3202-44-H2-(*) ESM-3202-84-H2-(*) ESM-3202-66-H2-(*) ESM-3202-86-H2-(*)	ESM-3302-43-H-(*) ESM-3302-44-H-(*) ESM-3302-84-H-(*) ESM-3302-66-H-(*) ESM-3302-86-H-(*)	1/16" (1.6 mm) 1/16" (1.6 mm) 1/8" (3.2 mm) 3/32" (2.4 mm) 1/8" (3.2 mm)	3/64" (1.2 mm) 1/16" (1.6 mm) 1/16" (1.6 mm) 3/32" (2.4 mm) 3/32" (2.4 mm)	DE-ENERGIZED  ENERGIZED  Port C = Inlet Port B = Cyl Port Port A = Exhaust Port C connected to Port B; Port A blocked      Port B connected to Port A; Port C blocked
<b>THREE-WAY 3/2 DIRECTIONAL CONTROL</b> Air, Oil or Water	200 (14) 150 (10) 125 (8.6) 100 (6.9)	ESM-7202-43-H2-(*) ESM-7202-44-H2-(*) ESM-7202-56-H2-(*) ESM-7202-86-H2-(*)	ESM-7302-43-H-(*) ESM-7302-44-H-(*) ESM-7302-66-H-(*) ESM-7302-86-H-(*)	1/16" (1.6 mm) 1/16" (1.6 mm) 3/32" (2.4 mm) 1/8" (3.2 mm)	3/64" (1.2 mm) 1/16" (1.6 mm) 1/16" (1.6 mm) 3/32" (2.4 mm) 3/32" (2.4 mm)	DE-ENERGIZED  ENERGIZED  Port B = Inlet Port C = Outlet I Port A = Outlet II Port B connected to Port C; Port A blocked      Port B connected to Port A; Port C blocked
<b>THREE-WAY 3/2 MULTI-PURPOSE</b> Air, Oil or Water	150 (10) 100 (6.9) 75 (5.2)	ESM-8202-33-H2-(*) ESM-8202-44-H2-(*) ESM-8202-66-H2-(*)	ESM-8302-33-H-(*) ESM-8302-44-H-(*) ESM-8302-66-H-(*)	3/64" (1.2 mm) 1/16" (1.6 mm) 3/32" (2.4 mm)	3/64" (1.2 mm) 1/16" (1.6 mm) 3/32" (2.4 mm)	DE-ENERGIZED  ENERGIZED  Multi-purpose valves may be used as Three-Way,NC or Three-Way, NO or Directional Control Valves. Two-Way, NC or Two-Way, NO can be accomplished by plugging the appropriate port.

**NOTES:**

- \*Specify Voltage: See "Coil Code" definition page 7
- For General Purpose coil voltages see page 4.
- For Hazardous Location coil voltages see page 7.
- For additional (-XX) options see page 5

†Pressures are for both AC or DC coil unless two pressures are shown. In that case, the pressure in color is for DC. Vacuum is AC only.

# SERIES E

## Manifold-Mounting Types

Each Series E Full-Size Manifold Mounting valve is direct solenoid actuated and is mounted on a manifold which can have 1 to 10 valve stations. The manifolds are provided with the threaded ports for pipe connections, which allows the valves to be easily and swiftly installed or removed without breaking any pipe connections. The manifolds also provide common ports, such as the inlet and exhaust, making only one such connection necessary per manifold. Installation is neater and maintenance easier since valves are grouped in one location. Several different piping arrangements are available to provide flexibility of application.

Valves are supplied assembled to manifolds, but must be ordered separately. Station Blanks (E-189) are available for blocking off any unused or "future" valve stations on the manifold. To order complete unit, specify manifold desired and quantity and valve model number required. Valves must all be same model.

Function	2-Way NC, 2-Way NO, 3-Way NC, 3-Way NO, Directional & Multi-Purpose
Pressure:	to 250 psi (see table page 21)
Media:	Air, Oil, Water
Flow:	to 0.26 Cv (see table below)
Temperature:	0°F to 180°F (-18°C to 82°C)
Ports, Inlet & Outlet:	1/8" or 1/4" NPT
Exhaust/vent:	Vent to atmosphere, #10-32 thread (NPT port or dust protectors available)
Voltages:	AC or DC (General Purpose see page 4) (Hazardous Location see page 7)
Coil rating:	Class F, continuous duty (Class H optional)
Power:	7.3 - 12 watt
Connections:	1/2" NPT
Ingress protection:	NEMA 1, 2,3 & 4/4X, General Purpose NEMA 1, 2,3 & 4/4X, Hazardous Location NEMA 7, 9 & 4/4X
Materials of construction:	
Body:	430 Stainless (316 Stainless Steel optional)
Seals	NBR (Nitrile)
Coil:	Epoxy molded
Manifold:	Aluminum
Mounting:	(2) threaded holes (optional bracket -WE)

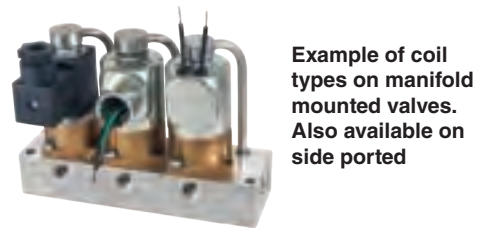
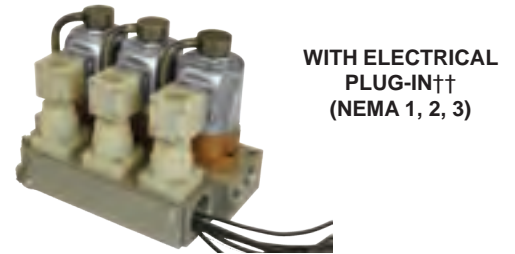

**MANIFOLD FEATURES:** Piped Exhaust; Common inlet for all valves; Individual outlets (cylinder ports) for each valve; Common exhaust port for all valves.

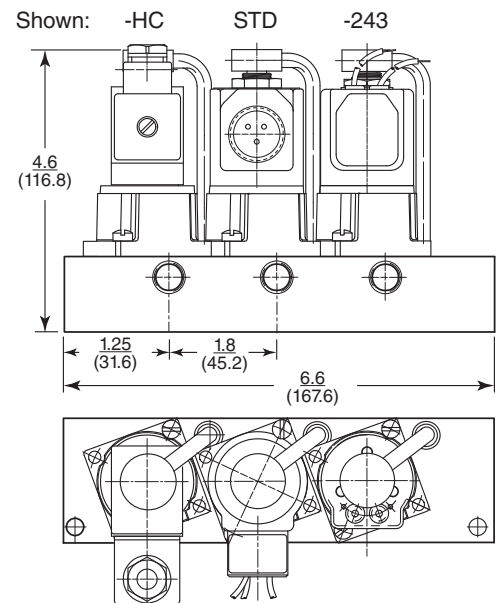
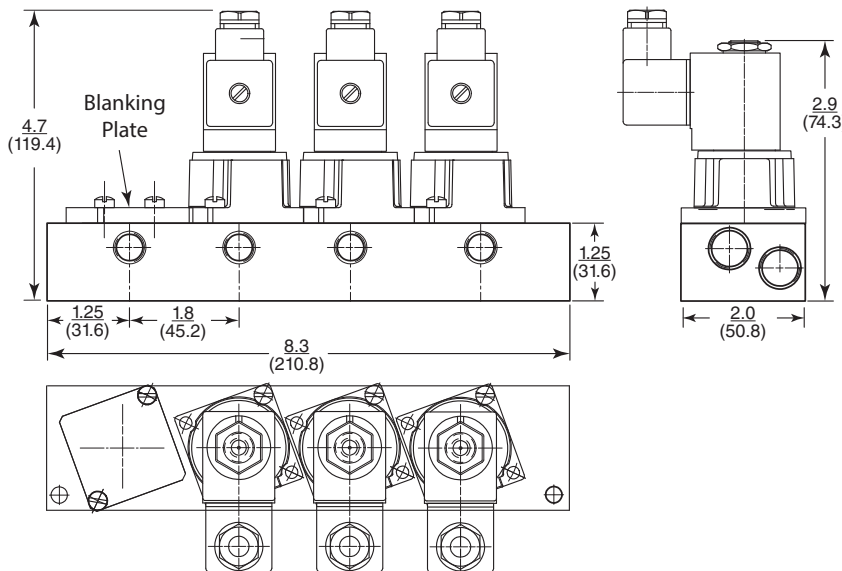

DIMENSIONS SHOWN IN INCH (MM)

		GENERAL PURPOSE (For Coil Voltages See Page 4)				
Type	Maximum Operating Pressure Differential psi (bar)†	Product Number				
		Valve		Manifold**		
		Listed with conduit type coil housing.	Min. Orifice between Valve Ports	One Inlet (3/8 NPT) Serves All Valves: Individual Outlets (1/4 NPT)	Individual Inlet (1/4 NPT) and Outlet (1/4 NPT) for Each Valve	Individual Inlet (1/4 NPT) for Each Valve; One Outlet (3/8 NPT) Serves All
<b>TWO-WAY 2/2 NORMALLY CLOSED</b> Air, Oil or Water	250 (17) 200 (14) 125 (8.6) 100 (6.9) 75-50 (5.2-3.4) 50-25 (3.4-1.7) 20-5 (1.4-0.3)	<b>ESM-2011-30-(*)</b> <b>ESM-2011-40-(*)</b> <b>ESM-2011-60-(*)</b> <b>ESM-2011-80-(*)</b> <b>ESM-2011-100-(*)</b> <b>ESM-2011-120-(*)</b> <b>ESM-2011-160-(*)</b>	3/64" (1.2 mm) 1/16" (1.6 mm) 3/32" (2.4 mm) 1/8" (3.2 mm) 5/32" (4.0 mm) 3/16" (4.8 mm) 1/4" (6.4 mm)	EM-21-210-(††)	EM-21-220-(††)	EM-21-120-(††)
<b>TWO-WAY 2/2 NORMALLY OPEN</b> Air, Oil or Water	200 (14) 150 (10) 125 (8.6)	<b>ESM-2012-03-Z-(*)</b> <b>ESM-2012-04-Z-(*)</b> <b>ESM-2012-06-Z-(*)</b>	3/64" (1.2 mm) 1/16" (1.6 mm) 3/32" (2.4 mm)	EM-22-012-(††)	EM-22-022-(††)	—
<b>THREE-WAY 3/2 NORMALLY CLOSED (EXHAUST TO ATMOSPHERE)</b> Air Only	150 (10) 100 (6.9) 75 (5.2) 50 (3.4) 20 (1.4) Vacuum-AC Only	<b>ESM-3011-34-(*)</b> <b>ESM-3011-44-(*)</b> <b>ESM-3011-66-(*)</b> <b>ESM-3011-86-(*)</b> <b>ESM-3011-126-(*)</b> <b>ESM-3011-166-(*)</b>	"In" "Cyl"	EM-31-120-(††)	EM-31-220-(††)	EM-31-210-(††)
			"Cyl" "Exh"			
<b>THREE-WAY 3/2 NORMALLY CLOSED (COMMON PIPED EXHAUST)</b> Air, Oil or Water	150 (10) 100 (6.9) 75 (5.2) 50 (3.4) 20 (1.4) Vacuum-AC Only	<b>ESM-3011-34-Z-(*)</b> <b>ESM-3011-44-Z-(*)</b> <b>ESM-3011-66-Z-(*)</b> <b>ESM-3011-86-Z-(*)</b> <b>ESM-3011-126-Z-(*)</b> <b>ESM-3011-166-Z-(*)</b>	3/64" (1.2 mm) 1/16" (1.6 mm)	EM-31-121-(††)	EM-31-221-(††)	
			1/16" (1.6 mm) 1/16" (1.6 mm)			
<b>THREE-WAY 3/2 NORMALLY OPEN (COMMON PIPED EXHAUST)</b> Air, Oil or Water	150 (10) 100 (6.9) 100 (6.9) 75 (5.2) 75 (5.2)	<b>ESM-3012-43-Z-(*)</b> <b>ESM-3012-44-Z-(*)</b> <b>ESM-3012-84-Z-(*)</b> <b>ESM-3012-66-Z-(*)</b> <b>ESM-3012-86-Z-(*)</b>	3/64" (1.2 mm) 1/16" (1.6 mm)	EM-32-121-(††)		
			1/16" (1.6 mm) 1/8" (3.2 mm)			
<b>THREE-WAY 3/2 DIRECTIONAL CONTROL</b> Air, Oil or Water	200 (14) 150 (10) 125 (8.6) 100 (6.9)	<b>ESM-7012-43-Z-(*)</b> <b>ESM-7012-44-Z-(*)</b> <b>ESM-7012-66-Z-(*)</b> <b>ESM-7012-86-Z-(*)</b>	"In" "Out 1"	EM-72-212-(††)		
			"In" "Out 2"			
		<b>Add Suffix -XX to Valve Product Numbers Shown Above</b>	<b>{ HAZARDOUS LOCATIONS }</b>	<b>Change Prefix "EM" to "E7M." Example E7M-72-212-†</b>		

Orifice/Cv		
Code	Orifice	Cv
2	1/32"	0.022
3	3/64"	0.06
4	1/16"	0.11
6	3/32"	0.21
8	1/8"	0.26
10	5/32"	0.45
12	3/16"	0.56
16	1/4"	0.79

**NOTES:**

- \*Specify Voltage: See "Coil Code" definition page 7.  
For General Purpose coil voltages see page 4.  
For Hazardous Location coil voltages see page 7.  
For additional (-XX) options see page 5

\*\* All ports of single station manifolds are 1/4 NPT.

† Pressures are for both AC or DC coil unless two pressures are shown. In that case, the pressure in color is for DC. Vacuum is AC only.

†† Specify number of valve stations required, 1 thru 10. For Plug-In solenoid add (P) (example: EM-31-120-4P).

# SERIES E3 *Inline Valve*

An inline, compact, heavy duty solenoid valve designed for the most extreme environments. Valve and coil housing are stainless steel for superior corrosion resistance and factory sealed. Rated for hazardous location service. Worldwide certifications available. 1/4" NPT 3-Way Valves for air, gas, oil or water. Male inline conduit hub for ease of installation. Super low watt option available for applications where power is a premium.

Part Number	CSA		ATEX	
	Standard Wattage	Super Low Wattage	Standard Wattage	Super Low Wattage
Pressure	0-150 psi (0-10.3 bar)	0 – 115 psi (0-7.9 bar)	0-150 psi (0-10.3 bar)	0 – 115 psi (0-7.9 bar)
Media	Air, Gas, Hydraulic			
Flow-Inlet, Cv/orifice:	0.11 / 0.063" (1.6 mm)	0.06 / 0.047" (1.2 mm)	0.11 / 0.063" (1.6 mm)	0.06 / 0.047" (1.2 mm)
Flow-Exhaust, Cv/orifice:	0.16 / 0.094" (2.4 mm)	0.16 / 0.094" (2.4 mm)	0.16 / 0.094" (2.4 mm)	0.16 / 0.094" (2.4 mm)
Power:	1.86 watts	0.85 watt	1.86 watts	0.85 watt
Voltage:	12 or 24 DC ± 15%	24 DC ± 15%	12 or 24 DC ± 15%	24 DC ± 15%
Ingress protection:	NEMA 4X and 6P		IP 66/67	
Coil Rating:	Class F, Continuous duty			
Electrical Connection:	1/2" npt, male hub with 72 inch wire leads, 3 wire. Not polarity dependent			
Ports:	1/4" NPT Inlet, Outlet & Exhaust			
Temperature	-4 to 122 F (-20 to 49 C)			
Materials:				
Body:	316 Stainless Steel			
Seals:	FKM-fluorocarbon			
Coil Housing:	316 Stainless Steel			
Coil:	Epoxy molded/encapsulated (Factory Sealed)			
Mounting:	Inline off conduit hub. Not orientation sensitive			



Rating: Class I, Div 1, Group C and D  
Class II, Div 1, Group E, F and G, T6  
Class I, Div 2, Group C and D  
Class II, Div 2, Group E, F and G

II 2 G Ex d IIB T4...T6 Gb

\*Specify Voltage: 12VDC (D012) or 24VDC (D024)

## Dimensions

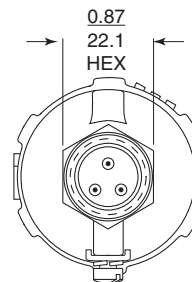
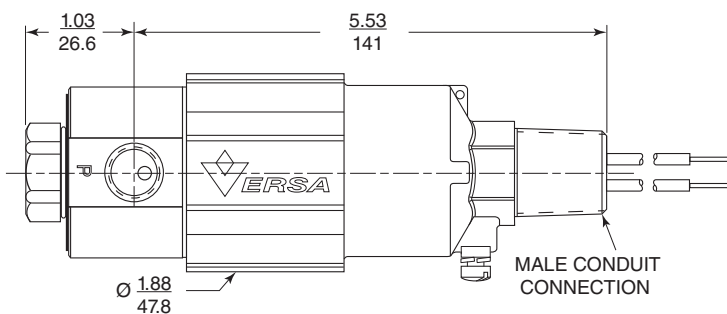

## FLOW SCHEMATIC

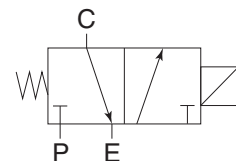

## Functional Description

The Electric Quick Exhaust Valve is a three-way, NC, 3/2 valve with extra large exhaust orifice in order to provide extra fast movement of the cylinder rod, or to exhaust systems rapidly. When the solenoid is energized, the outlet port is connected to the inlet port and the exhaust port is closed. When the solenoid is de-energized, the inlet port is closed and the outlet port is connected to the exhaust port, providing rapid evacuation of the system.

## Construction

Body: 316 Stainless Steel (Conforms to NACE standard MR-01-75)

Solenoid Operator: 304, 430F & 302 Stainless Steel (wetted parts)

Seals: FKM (Fluorocarbon) O ring seals;  
CR (Neoprene) coated nylon flapper.  
Screws: Stainless Steel



Function	Size			Pressure	E5QE		E4QE		EQE					
					General Purpose, NEMA 1 (none) General Purpose, NEMA 4/4X (-PC) UL/CSA, flying lead 1/2" conduit hub (-XX) ATEX, flying leads M20 conduit hub (-XN) FM/CSA, Intrinsic Safe, DIN (-XIS*)		CSA/ATEX, junction box (-XDB*1)		ATEX, (m) junction box (-XMA*) ATEX, (i) junction box (-XIF*)					
3-Way 3/2 Normally Closed	Basic	Ports		Part Number	Flow		Part Number	Flow		Part Number	Flow			
		Inlet	Outlet		Exhaust	Inlet		Exhaust	Inlet		Exhaust	Inlet	Exhaust	
	1/4	1/4	1/4	3/8	5-150	E5QE-30304-316-*.**	0.06	3.3	E4QE-30304-316-*.**	0.06	3.3			
					5-100	E5QE-30404-316-*.**	0.11	3.3	E4QE-30404-316-*.** (125 psi)	0.11	3.3			
	1/2	1/4	1/2	3/4	5-150	E5QE-50304-316-*.**	0.06	8.8	E4QE-50304-316-*.**	0.06	8.8	EQE-50203-316-*.**	0.022	8.8
					5-100	E5QE-50404-316-*.**	0.11	8.8	E4QE-50404-316-*.** (125 psi)	0.11	8.8	EQE-50304-316-*.**	0.06	8.8

\* Specify Suffix Options from chart below. \*\*Specify Voltage.

SUFFIX CHART (for additional specifications Description contact factory)	Suffix			
	E5QE	E4QE	EQE	
<b>General Purpose</b>	E5QE	E4QE	EQE	
NEMA 1, 1/2" Conduit, 24" wire leads (standard no suffix required)	None	NA	NA	
NEMA 4, 4X 1/2" Conduit, 24" wire leads	-PC			
<b>Hazardous Location</b>				
UL/CSA Explosion Proof, 1/2" Conduit, 24" wire leads. For other available options see page 5	-XX	-XV	NA	
ATEX/IEC Flame Proof (d), M20 Conduit, 24" wire leads (-XN). ATEX/IEC Flame Proof (d), 1/2" Conduit, 24" wire leads (-XT). For other available options see page 5	-XN	-XT		
FM/CSA Intrinsic Safe, Spade terminals. Other available options: -HC DIN Connector, Pg9 cord grip -HCC DIN Connector, 1/2" conduit Note: Part number changes to E5QE-30202-316 and E5QE-50202-316. Pressure is 5-115 psi (0.3-7.9 bar) and Inlet Flow is 0.02 Cv (.32 Kv)	-XISC (FM/CSA) -XISX6 (ATEX)	NA		
ATEX/IECEx/CSA Flame Proof (d), Increased Safety(e), Enclosure/Dust (td) Class I, Div I, Grp B,C,D - Class I, Div II, Grp E,F,G- Class I, Div III, integral junction box	NA	-XDBS1 (M20) -XDBT1 (1/2" npt)	NA	
ATEX/IECEx Encapsulated (mb), Increased Safety (e) Enclosure/Dust (td) integral junction box				-XMAA (M20) -XMAF (1/2")
Intrinsic Safe (ia), integral junction box				-XIFA (M20) -XIFF (1/2" npt)

**(For Pneumatic Application Only)**



**Versa has been supplying the fluid power industry with pneumatic and hydraulic components for over 50 years. We have built a reputation for quality that is unsurpassed in the market for high performance solenoids, pneumatic relays, resets and pilot valves.**

**WARNINGS REGARDING THE DESIGN APPLICATION, INSTALLATION AND SERVICE OF VERSA PRODUCTS**

The warnings below must be read and reviewed before designing a system utilizing, installing, servicing, or removing a Versa product. Improper use, installation or servicing of a Versa product could create a hazard to personnel and property.

**DESIGN APPLICATION WARNINGS**

Versa products are intended for use where compressed air or industrial hydraulic fluids are present. For use with media other than specified or for non-industrial applications or other applications not within published specifications, consult Versa.

Versa products are not inherently dangerous. They are only a component of a larger system. The system in which a Versa product is used must include adequate safeguards to prevent injury or damage in the event of system or product failure, whether this failure be of switches, regulators, cylinders, valves or any other system component. System designers must provide adequate warnings for each system in which a Versa product is utilized. These warnings, including those set forth herein, should be provided by the designer to those who will come in contact with the system.

Where questions exist regarding the applicability of a Versa product to a given use, inquiries should be addressed directly to the manufacturer. Confirmation should be obtained directly from the manufacturer regarding any questioned application prior to proceeding.

**INSTALLATION, OPERATION AND SERVICE WARNINGS**

Do not install or service any Versa product on a system or machine without first depressurizing the system and turning off any air, fluid, or electricity to the system or machine. All applicable electrical, mechanical, and safety codes, as well as applicable governmental regulations and laws must be complied with when installing or servicing a Versa product.

Versa products should only be installed or serviced by qualified, knowledgeable personnel who understand how these specific products are to be installed and operated. The individual must be familiar with the particular specifications, including specifications for temperature, pressure, lubrication, environment and filtration for the Versa product which is being installed or serviced. Specifications may be obtained upon request directly from Versa. If damages should occur to a Versa product, do not Operate the system containing the Versa product. Consult Versa for technical information.

**LIMITED WARRANTY DISCLAIMER AND LIMITATION OF REMEDIES**

Versa's Series products are warranted to be free from defective material and workmanship for a period of ten years from the date of manufacture, provided said products are used in accordance with Versa specifications. Versa's liability pursuant to that warranty is limited to the replacement of the Versa product proved to be defective provided the allegedly defective product is returned to Versa or its authorized distributor. Versa provides no other warranties, expressed or implied, except as stated above. There are no implied warranties of merchantability or fitness for a particular purpose. Versa's liability for breach of warranty as herein stated is the only and exclusive remedy and in no event shall Versa be responsible or liable for incidental or consequential damages.

Versa Products Company Inc.  
22 Spring Valley Road  
Paramus, New Jersey 07652  
USA  
Phone: 201-843-2400  
Fax: 201-843-2931

Versa BV  
Prins Willem Alexanderlaan  
1429  
7321 GB Apeldoorn  
The Netherlands  
Phone: 01131-55-368-1900  
Fax: 01131-55-368-1909

