

Inductive linear displacement transducers

Model IW250

Measuring strokes: 20 mm, 40 mm, 100 mm, 200 mm

Document no.: IW 10225 KE

Date: 20.10.2020



- Contactless, robust sensor system
- Infinite resolution, no hysteresis
- Calibrated output signals:
0...20 mA, 4...20 mA, ± 10 V, 0...10 V
- Integral electronics for DC in / DC out
- Accuracy up to 0.1%
- Gauge type up to 100 mm
- Protection class up to IP 68

Construction and operating principle

The displacement transducer operates according to the principle of the differential choke, i.e. an inductive half bridge. It consists of two coils which are encapsulated in a stainless steel cylinder. A mu-metal plunger core causes opposing changes of inductance when it is displaced through the centre of the coils. These changes are converted by the integral electronic circuit into a signal proportional to the displacement. The circuit contains an oscillator, demodulator, amplifier and in some cases, a current output source. It is short-circuit proof and protected against reverse polarity. The transducers are completely sealed to ensure positive protection against vibration, shock, humidity, oil and corrosive matter.

Standard measuring strokes: 20 mm, 40 mm, 100 mm, 200 mm

The following variants can be supplied upon request:

- Extension of above measuring strokes depending on accuracy tolerances as follows (without increase of case length):
 - for 0.5% tolerances: standard stroke + 15 mm
 - for 0.25% tolerances: standard stroke + 10 mm
- Calibration of shorter strokes within the above standard ranges (without change of case length), e.g. IW 251/40 becomes IW 251/30, i.e. 0 to 30 mm equals 0 to 20 mA.
- Measuring strokes up to 270 mm within case of IW 250 /200 (requiring larger linearity tolerances and longer plunger length). Subject to special agreement.

Note: The type IW 255 replaces the previous type IW 25 and is fully interchangeable with it, both mechanically and electrically.

Standard versions and calibrations

Type	Output-signal	V_s^{**}	Output sense *	Mid-point at
IW 251	0...20 mA	21.5 - 32 V	increasing	10 mA
IW 252			decreasing	
IW 253	4...20 mA	21.5 - 32 V	increasing	12 mA
IW 254			decreasing	
IW 255	± 10 V	$\pm 13 - \pm 16$ V	increasing	0 V
IW 256			decreasing	
IW 25A	0...10 V	21.5 - 32 V	increasing	5 V
IW25B			decreasing	
IW 259	Special variants			

* Increasing means that the output signal increases positively when the plunger is moved in the direction towards the plug.

** Other supply voltages upon request.

Inductive linear displacement transducers model IW250

Technical data

Technical data

■ Supply voltage range V_S :	21.5 to 32 VDC or ± 13 to ± 16 VDC (protected against reverse polarity)
■ Accuracy :	$\pm 0.1\%$, $\pm 0.25\%$, $\pm 0.5\%$
■ Temperature drift :	$< 0.01\%/^{\circ}\text{C}$
■ Stability :	$< 0.1\%$ in 24 hours
■ Measurement frequency :	100 Hz max.
■ Operating temperature range :	-10°C to $+80^{\circ}\text{C}$
■ Storage temperature range :	-30°C to $+80^{\circ}\text{C}$
■ Resistance to shock :	250g SRS at 20 at 2000 Hz
■ Resistance to vibration :	20g rms (50g peak) at 20 to 2000 Hz
■ Protection class :	IP 66 (with connector) IP 68 (with cable)

Current output (IW 251 to IW 254)

■ Output signal :	0...20 mA or 4...20 mA
■ Supply current I_S :	60 mA max.
■ Load resistance R_L :	0...500 Ω
■ Ripple :	$< 0.005 \text{ mA}_{\text{P-P}}$
■ Dependence on R_L :	$< 0.001\%$ for $\Delta R_L = 100 \Omega$
■ Dependence on V_S :	$< 0.05\%$ for $\Delta V_S = 1 \text{ V}$
■ Maximum output current :	25 mA

Voltage output (IW 255 to IW 25B)

■ Output signal :	± 10 VDC or 0...10 VDC*
■ Supply current I_S :	50 mA max.
■ Permissible load R_L :	2 k Ω (short-circuit proof)
■ Ripple:	$< 5 \text{ mV}_{\text{P-P}}$
■ Dependence on V_S :	$< 0.05\%$ for $\Delta V_S = 1 \text{ V}$

* Residual voltage 0.1 VDC max.

Note: Unless otherwise stated, all values are valid at $+20^{\circ}\text{C}$ ambient temperature and 24 VDC or ± 15 VDC supply voltage, starting 10 minutes after switch-on.

Special Versions and accesories

SR: Protective tube in stainless steel or glass fiber reinforced plastic to protect plunger, against lateral stress (ref. to data sheet 11537).

Version T: Gauge type with return spring (available for 20, 40 and 100 mm stroke).

Version KV: With ball joint on plunger without guide.

Version KFN: With ball joint on plunger and special guide.

Version KHN: With ball joint on case (plug end). Can be combined with KFN.

Version PKSx: With cable gland. S = silicon cable connection 3 wire shielded

Version PKx: With cable gland. Cable connection, x = cable length.

Mating plug: Coupling socket to be ordered separately.

MB 25: Mounting block with clamp fixing (must be ordered separately).

Inductive linear displacement transducers model IW250

Technical data

Electrical connections

(with view on the contacts at the transducer case)

IW 251, IW 252, IW 253, IW 254, IW 25A u. IW 25B	IW 255 und IW 256
1 = $+U_B$ 2 = $-U_B$ (0V) $-I_A$ 3 = $+I_A / U_A$ (output signal)	1 = $+U_B$ 2 = 0V (common) 3 = $-U_B$ 4 = $+U_A$ (output signal)

Materials

- External and internal tube: Chrome-nickel steel
- Plunger: Chrome-nickel steel
- Core: Mu-metal
- Connector case: Brass, nickel-plated
- Connector contacts: Gold-plated
- Spring and gauge head: Stainless steel ("T")

Calibration

Both the sensor system and the plunger core are calibrated as one unit. They carry the same serial number.

Lengths and masses (refer to drawings page 4)

Type	L1* mm	L2 mm	without plunger g	plunger only g
IW 250/20	40	110	210	15
IW 250/40	50	140	240	19
IW 250/100	80	250	380	31
IW 250/200	130	500	720	56
KV or KFN	22 g			
KHN	55 g			

* L1 = Plunger in central position: $I_0 = 10$ (12) mA, resp. $V_0 = 0$ (5) V.

Order code format

IW 252 / 200 - 0,1 - KFN - KHN

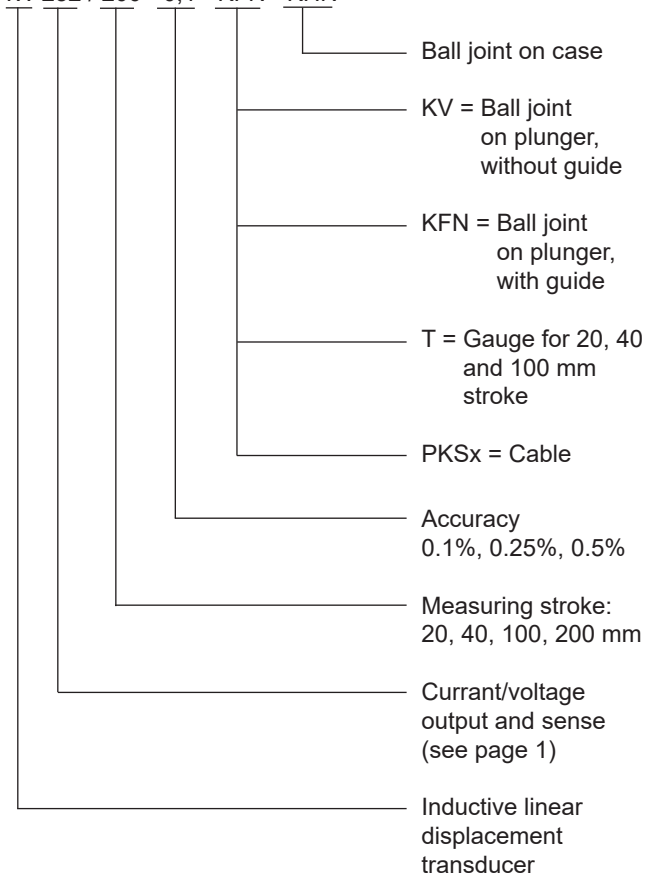

* The applicable A-No. is allocated after the definition of the deviation when ordering. No A-No. is given for standard versions as specified in the data sheet.

Inductive linear displacement transducers model IW250

Installation drawing

Standard version, without rod guide

Dimensions in mm

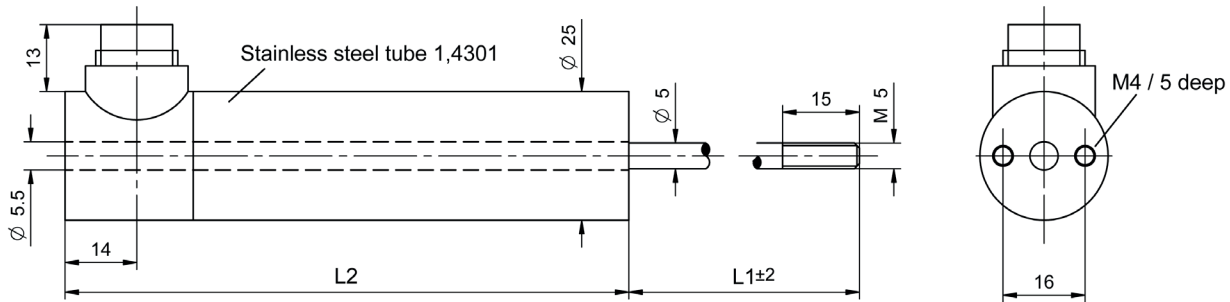

Version with ball joint on plunger (KV), without rod guide

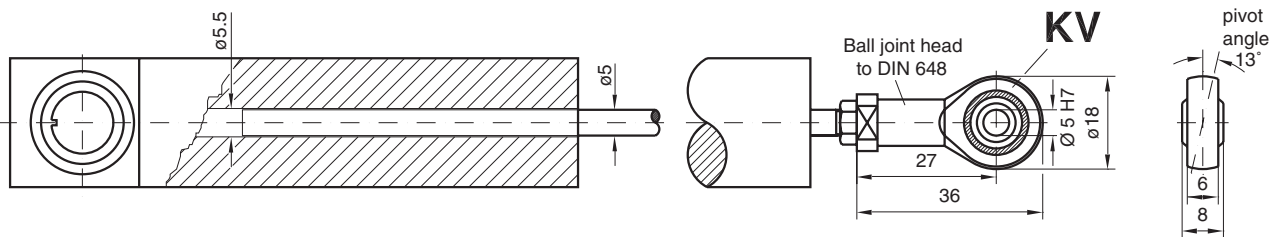

Version with ball joint on plunger (KFN) and on end of case (KHN), with rod guide, captivated

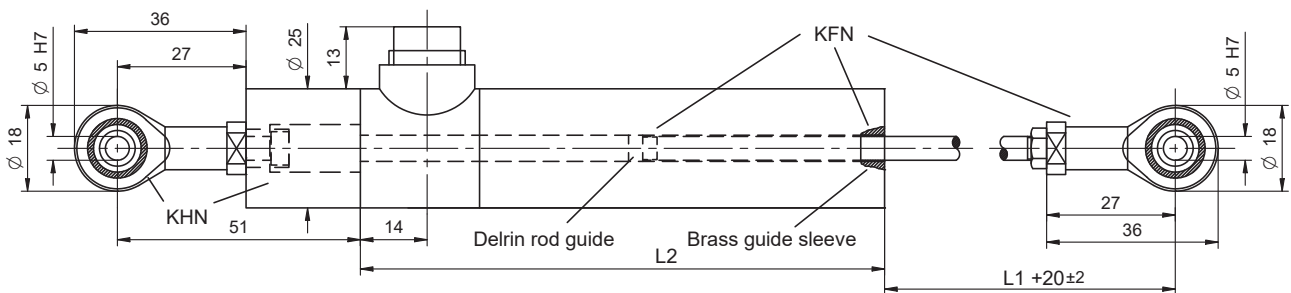

**Gauge version (T) with return spring (up to 100 mm stroke),
Version (PK) with cable exit with gland**

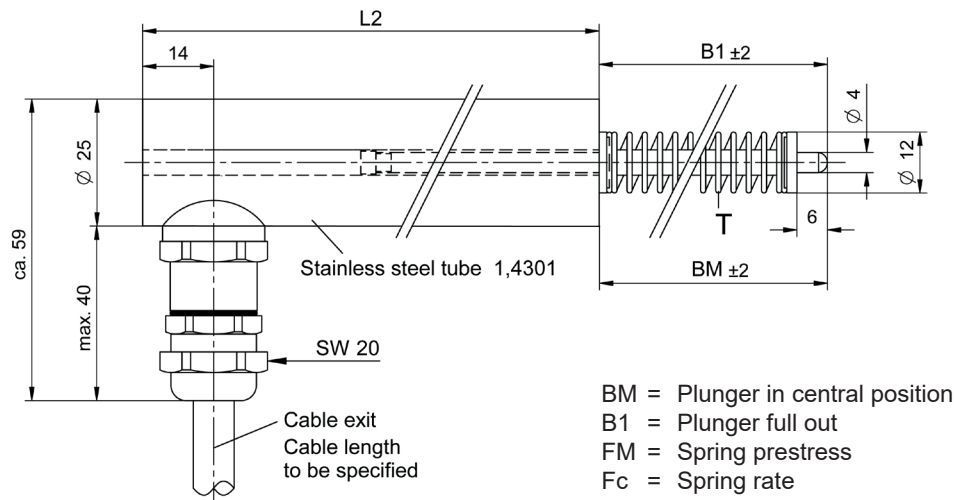

Inductive linear displacement transducers model IW250

Electrical connections

IW251, IW252, IW253, IW254, IW25A und IW25B	IW255 und IW256
yellow = $+V_s$ blue = $-U_s$ (0V) - I_o black = $+I_o/V_o$ (output)	brown = $+V_s$ yellow = 0V (GND) white = $-V_s$ green = $+V_o$ (output)

Measuring stroke mm	BM mm	B1 mm	FM N	Fc N/mm
20	70	85	~ 4	0.14
40	70	98	~ 4	0.07
100	140	198	~ 4	0.03

Mating plugs

Metal housing with ground loop (to be ordered separately)
 STK3GS111 3-pole
 STK4GS112 4-pole
 Cable entry with strain relief
 For cables with 6-8mm Ø IP67

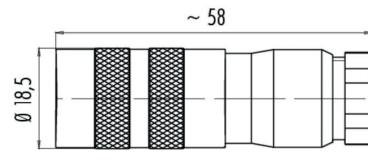

MB 25 Mounting block

brass nickel plated (to be ordered separately)

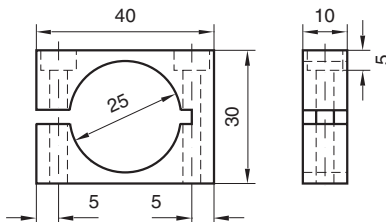

2 hexagon socket screws M4/35 mm are supplied with each item

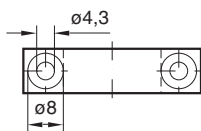

Mass: 60 g