



Vibrating level switch

- For universal applications such as limit level detection or run-dry protection
- Installation without adjustment
- Minimal installation dimensions
- Available in IO-Link variant

Product variants described in the data sheet may differ from the product presentation and description.

Can be combined with

	Type 2030 Pneumatically operated 2/2-way diaphragm valve CLASSIC with plastic valve body	▶
	Type 8644 AirLINE SP electropneumatic automation system	▶
	Type 2301 Pneumatically operated 2-way Globe Control Valve	▶
	Type 8619 multiCELL - Multi-channel and multi-function transmitter/controller	▶

Type description

The device Type 8110 is a filling level switch for liquids, using a tuning fork as the sensor element.

It is designed for industrial use in all areas of process technology and can be used in liquids. Typical applications are overflow or run-dry protection.

The small tuning fork (40 mm in length) can be used in vessels, tanks and pipes.

Due to the simple and robust measuring system, the Type 8110 is virtually unaffected by the chemical and physical features of the liquid. It works even under unfavourable measurement conditions such as turbulence, air bubbles, foam generation (not suitable for measuring the foam thickness itself), adhesions, strong external vibrations or varying filling materials.

The digital interface IO-Link allows bidirectional data transfer with any IO-Link Master. Data access is provided by using the available standardised IO-Link corresponds to specification version 1.0.

DTS 1000079485 EN Version: O Status: RL (released | freigegeben | validé) printed: 18.12.2023

Table of contents

1. General technical data	3
1.1. About the device	3
1.2. All variants.....	3
1.3. Vibrating level switch with PNP transistor output	4
1.4. Vibrating level switch with contactless electronic switch output.....	4
1.5. Vibrating level switch with IO-Link output	4
2. Approvals and conformities	5
2.1. Conformity	5
2.2. Standards.....	5
3. Materials	5
3.1. Bürkert resistApp	5
3.2. Material specifications	5
4. Dimensions	6
4.1. G ½" or NPT ½" connection	6
4.2. G ¾" or NPT ¾" connection	6
4.3. G 1" or NPT 1" connection	7
4.4. Clamp 2" connection	7
5. Performance specifications	8
5.1. Temperature derating diagram	8
G or NPT connection	8
Clamp connection.....	8
6. Product installation	9
6.1. Installation notes	9
7. Product operation	9
7.1. Measuring principle.....	9
8. Ordering information	10
8.1. eShop.....	10
8.2. Bürkert product filter.....	10
8.3. Ordering chart.....	10
8.4. Ordering chart accessories.....	11

1. General technical data

1.1. About the device

The vibrating level switch is available with PNP transistor output, with contactless electronic switch output or with a digital output in IO-Link operation. The technical data depends on the vibrating level switch variant.

1.2. All variants

Product properties	
Material	
Make sure the device materials are compatible with the fluid you are using. Further information can be found in chapter “3.1. Bürkert resistApp” on page 5.	
Further information on the materials can be found in chapter “3.2. Material specifications” on page 5	
Surface quality	Ra < 3.2 µm (thread) / Ra < 0.8 µm (clamp)
Dimensions	Further information can be found in chapter “4. Dimensions” on page 6.
Weight	Approx. 250 g
Measured quantity	Limit level of liquids
Operating mode	<ul style="list-style-type: none"> • Min./max: changeover by electrical connection <ul style="list-style-type: none"> – Max.: max. detection or overflow protection – Min.: min. detection or dry run protection • LED indication: <ul style="list-style-type: none"> – Green (voltage supply on) – Yellow (vibrating element covered) – Red (fault)
Performance data	
Hysteresis	Approx. 2 mm with vertical installation
Switching delay	Approx. 500 ms (On/Off)
Electrical data	
Power source (not supplied)	Limited power source according to UL/EN 62368-1 standards or limited energy circuit according to UL/EN 61010-1 paragraph 9.4
Overvoltage category according to IEC 61010-1	Category III
Power consumption	Max. 0.5 W
Resonance frequency	Approx. 1100 Hz
Medium data	
Process temperature	-40...+100 °C (-40...+212 °F) (+150 °C (+302 °F) for clamp process connection)
Process pressure	-1...64 bar/-100...6400 kPa (-14.51...+928.64 PSI)
Dynamic viscosity η	0.1...10000 mPa.s
Density	Standard sensitivity: 0.7...2.5 g/cm ³ (High sensitivity: 0.5...2.5 g/cm ³ on request)
Flow velocity	Max. 6 m/s (with a viscosity of 10000 mPa.s)
Process/Pipe connection & communication	
Process connection	Thread G or NPT, ½", ¾" or 1"; clamp 2"
Approvals and conformities	
Directives	
CE directive	Further information on the CE Directive can be found in chapter “2.2. Standards” on page 5.
Environment and installation	
Ambient temperature	<ul style="list-style-type: none"> • Operating on the housing: -40...+70 °C (-40...+158 °F) • Storage and transport: -40...+80 °C (-40...+176 °F)
Temperature derating	Further information can be found in chapter “5.1. Temperature derating diagram” on page 8.
Relative air humidity	20...85 %, without condensation

1.3. Vibrating level switch with PNP transistor output

Electrical data	
Operating voltage	9.6...35 V DC
Protection class according to IEC 61010-1	II
Voltage loss	Max. 3 V DC
Switching voltage	Max. 34 V DC
Load current	Max. 250 mA (output, permanently short-circuit proof)
Blocking current	< 10 μ A
Process/Pipe connection & communication	
Electrical connection	Cable plug acc. to EN 175301-803 or M12 \times 1 male connector
Environment and installation	
Degree of protection according to IEC/EN 60529	<ul style="list-style-type: none"> • IP65 with cable plug EN 175301-803 mounted and tightened • IP66/IP67 with M12 \times 1 female connector mounted

1.4. Vibrating level switch with contactless electronic switch output

Electrical data	
Operating voltage	<ul style="list-style-type: none"> • 20...253 V AC, 50/60 Hz • 20...253 V DC
Protection class according to IEC 61010-1	I
Load current	<ul style="list-style-type: none"> • Min. 10 mA • Max. 250 mA
Process/Pipe connection & communication	
Electrical connection	M12 \times 1 male connector
Environment and installation	
Degree of protection according to IEC/EN 60529	IP66/IP67 with M12 \times 1 female connector mounted

1.5. Vibrating level switch with IO-Link output

Electrical data	
Operating voltage (V+)	9.6...35 V DC
Protection class according to IEC 61010-1	II
Max. resistive load	$R_A \leq 0.5 \text{ k}\Omega$
Switching voltage	\geq operating voltage (V+) - 2.7 V CC
Switching current	<ul style="list-style-type: none"> • With IO-Link: communication (C)-Switching output 1 (Q1) noted C/Q1: 100 mA • Switching output 2 (Q2): 250 mA
Power consumption	Max. 0.5 W
Connection cable	3-wire unshielded cable, max. 20 m
Process/Pipe connection & communication	
Electrical connection	M12 \times 1 male connector
Digital communication: IO-Link	
Communication interface	IO-Link device V1.1, downward compatible to V1.0
Baud rate (data transfer rate)	COM 3 (230.4 kBaud)
Cycle time	Min. 2 ms
IO device description (IODD)	Depending on the ordered measurement range See "Device Description Files" on our website under the "User Manuals" heading for Type 8110 \blacktriangleright or available at https://ioddfinder.io-link.com
Environment and installation	
Degree of protection according to IEC/EN 60529	IP66/IP67 with M12 \times 1 female connector mounted

2. Approvals and conformities

2.1. Conformity

In accordance with the Declaration of Conformity, the product is compliant with the EU Directives.

2.2. Standards

The applied standards which are used to demonstrate compliance with the EU Directives are listed in the EU-Type Examination Certificate and/or the EU Declaration of Conformity.

3. Materials

3.1. Bürkert resistApp

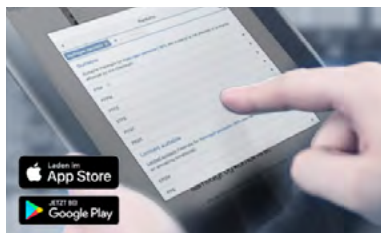

Bürkert resistApp – Chemical resistance chart

You want to ensure the reliability and durability of the materials in your individual application case? Verify your combination of media and materials on our website or in our resistApp.

[Start chemical resistance check](#)

3.2. Material specifications

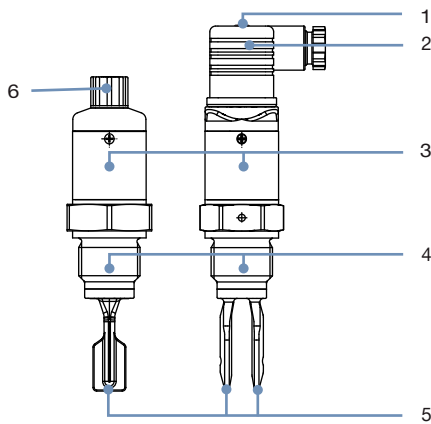

No.	Element	Material
1	Screw	Stainless steel
2	Cable plug EN175301-803	<ul style="list-style-type: none"> Contact support, housing plug in PA Contact surface in Sn Plug seal in silicone
3	Housing	Plastic PEI (Polyetherimide) and stainless steel 316L (1.4404)
4	Process connection	Stainless steel 316L (1.4435)
5	Tuning fork	Stainless steel 316L (1.4435)
6	Multipin M12 × 1 male connector with protective cap	<ul style="list-style-type: none"> Contact support in PA Contacts in CuZn, nickel layer and 0.8 µm gold-plated Plug seal in FKM
–	Process seal (not shown)	NBR with aramid fibres

4. Dimensions

4.1. G 1/2" or NPT 1/2" connection

Note:

Dimensions in mm, unless otherwise stated

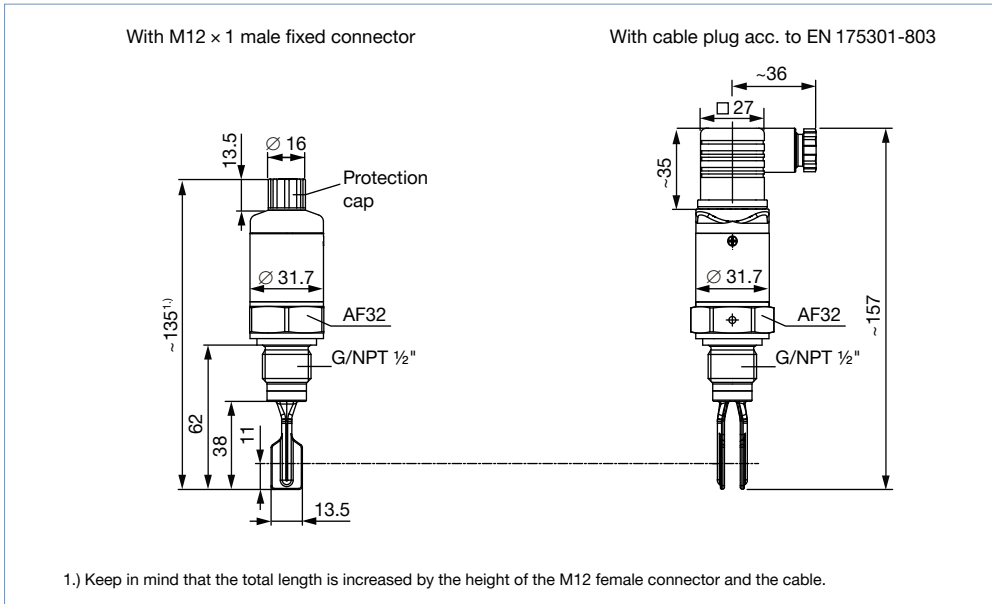

4.2. G 3/4" or NPT 3/4" connection

Note:

Dimensions in mm, unless otherwise stated

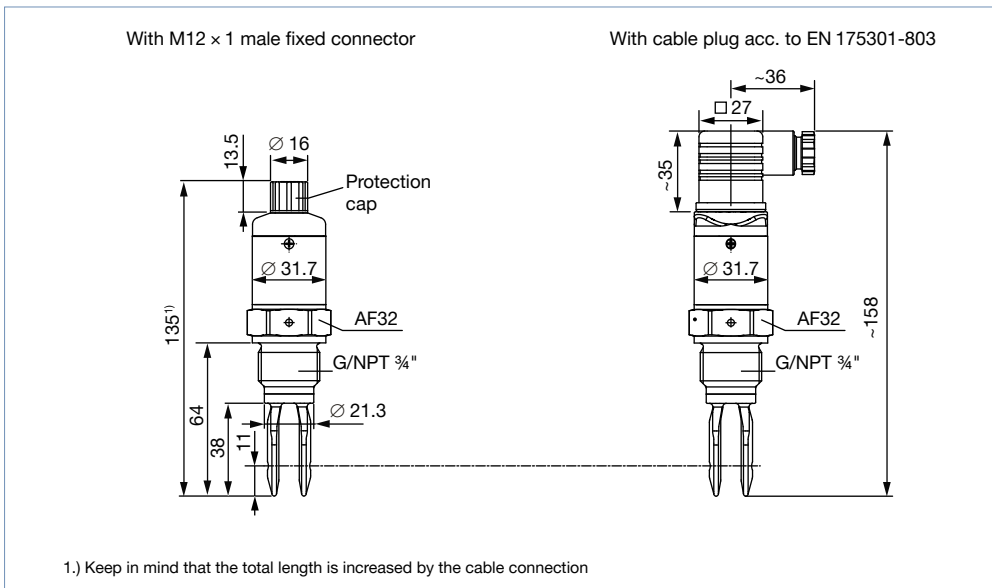

4.3. G 1" or NPT 1" connection

Note:

Dimensions in mm, unless otherwise stated

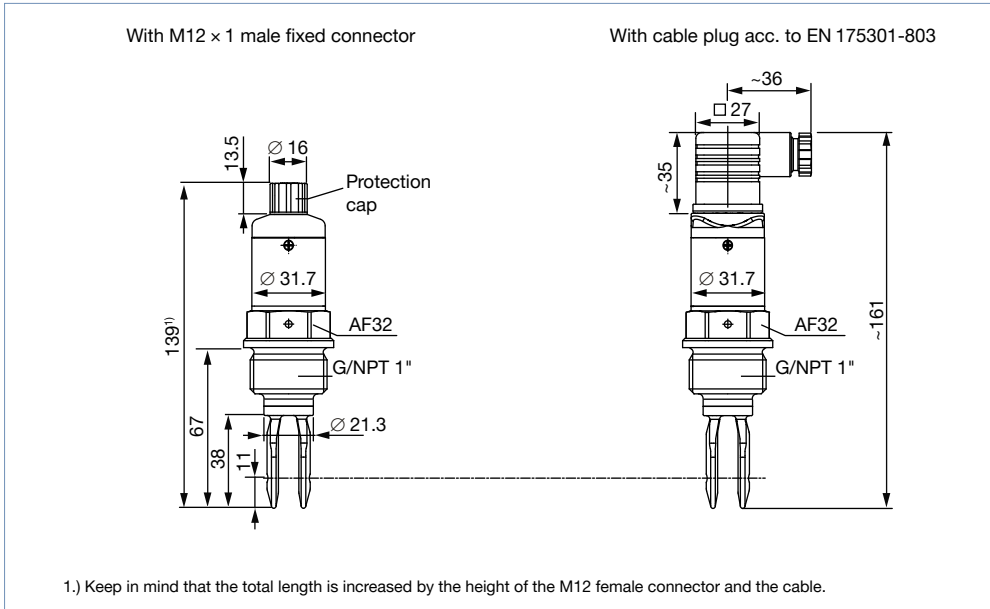

4.4. Clamp 2" connection

Note:

Dimensions in mm, unless otherwise stated

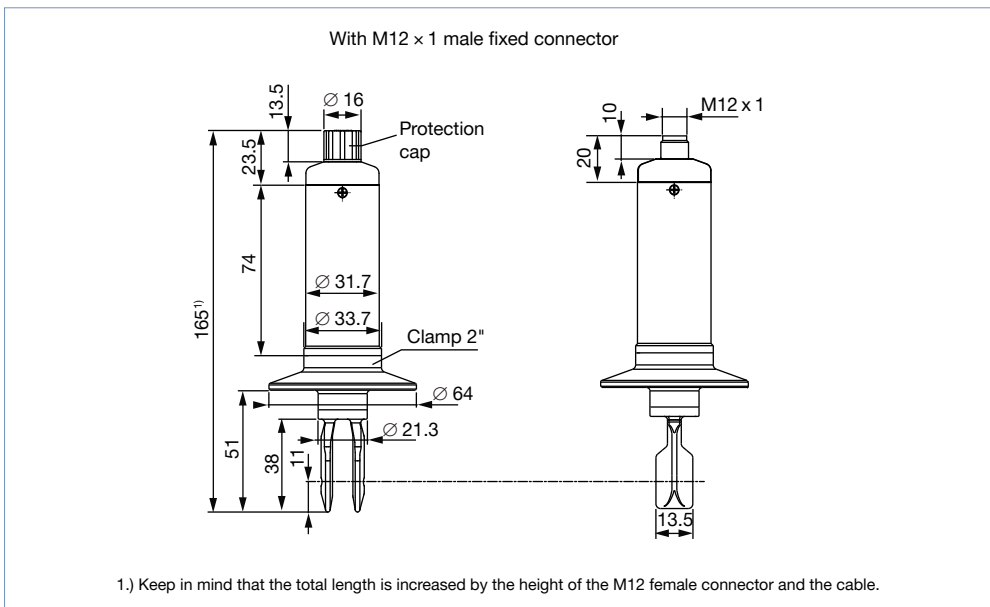

DTS 1000079485 EN Version: O Status: RL (released | freigegeben | valide) printed: 18.12.2023

5. Performance specifications

5.1. Temperature derating diagram

G or NPT connection

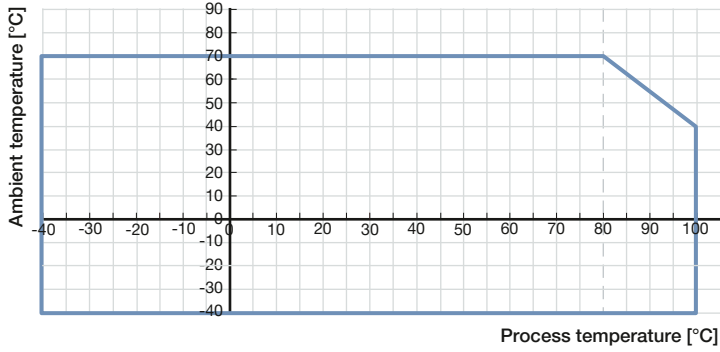

Clamp connection

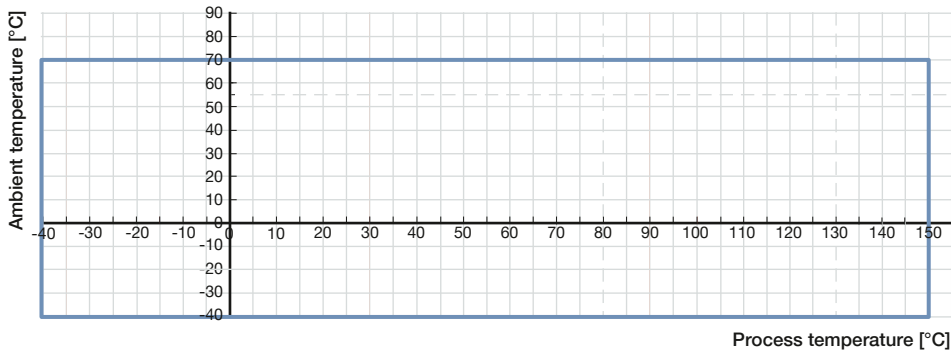

6. Product installation

6.1. Installation notes

Note:

- **Inflowing material:**

If the Type 8110 vibrating level switch is mounted in the filling stream, unwanted switching signals can be generated. Mount the switch at a location in the vessel where no disturbing influence from e.g. filling openings, agitators, etc. can occur.

- **Flow:**

If there is movement within the product, the tuning fork of the switch should be mounted in such a way that the surfaces of the fork are parallel to the product movement.

The Type 8110 vibrating level switch can be installed in any position. The instrument only has to be mounted in such a way that the tuning fork is at the height of the desired switching point.

The switching point refers to the medium water (1 g/cm³/0.036 lbs/in³). Please keep in mind that the switching point of the instrument shifts when the medium has a different density than water.

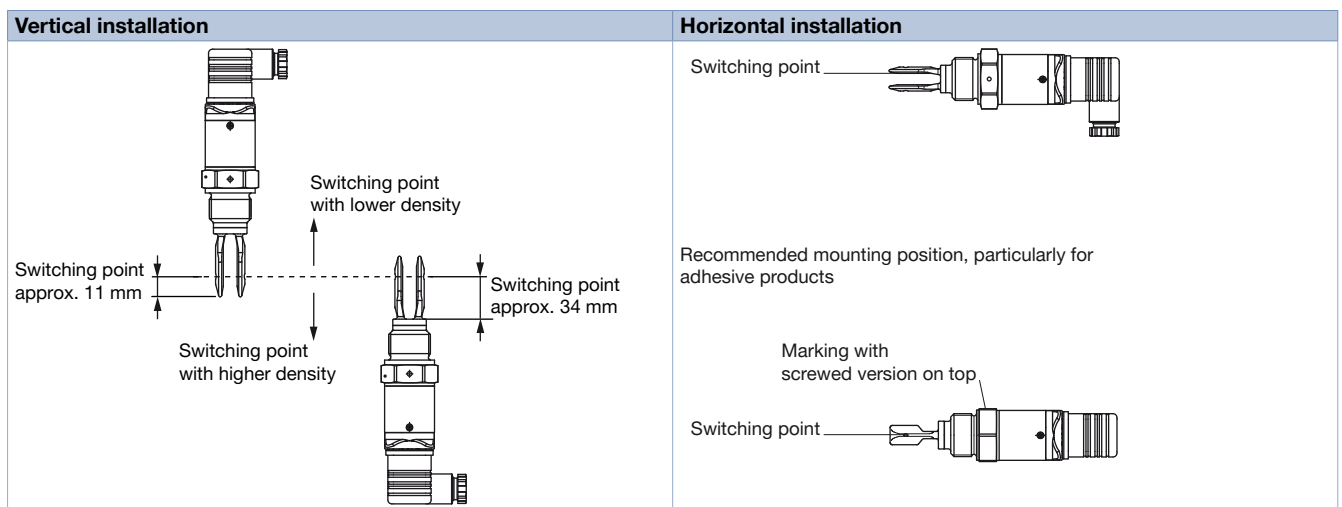

7. Product operation

7.1. Measuring principle

The tuning fork is piezoelectrically energised and vibrates at a mechanical resonance frequency of approx. 1100 Hz. When the tuning fork is submerged in the product, the frequency changes. This change is detected by the integrated oscillator and converted into a switching command.

The integrated fault monitor detects the following faults:

- Interruption of the connection cable to the piezoelectric elements
- Extreme material wear on the tuning fork
- Breakage of the tuning fork
- Absence of vibration.

If one of these faults is detected or in case the power supply fails, the electronic system switches to a defined switching state, e.g. the relay de-energises (safe state).

8. Ordering information

8.1. eShop



Bürkert eShop – Easy ordering and quick delivery

You want to find your desired Bürkert product or spare part quickly and order directly? Our online shop is available for you 24/7. Sign up and enjoy all the benefits.

[Order online now](#)

8.2. Bürkert product filter

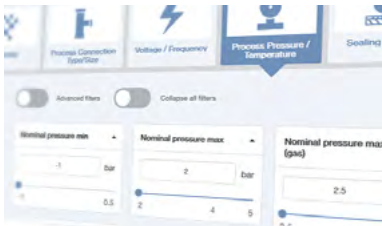

Bürkert product filter – Get quickly to the right product



You want to select products comfortably based on your technical requirements? Use the Bürkert product filter and find suitable articles for your application quickly and easily.

[Try out our product filter](#)



8.3. Ordering chart

Output	Operating voltage	Process connection	Electrical connection	Article no.
Transistor PNP	9.6...35 V DC	G 1/2"	Cable plug EN 175301-803	563554 🛒
			Multipin male connector M12 x 1	563474 🛒
		NPT 1/2"	Cable plug EN 175301-803	563556 🛒
			Multipin male connector M12 x 1	563555 🛒
		G 3/4"	Cable plug EN 175301-803	555291 🛒
			Multipin male connector M12 x 1	555290 🛒
		NPT 3/4"	Cable plug EN 175301-803	560986 🛒
			Multipin male connector M12 x 1	557154 🛒
G 1"	Cable plug EN 175301-803	555293 🛒		
	Multipin male connector M12 x 1	555292 🛒		
NPT 1"	9.6...35 V DC	Multipin male connector M12 x 1	557155 🛒	
		Clamp 2"	Multipin male connector M12 x 1	555294 🛒
Contactless electronic switching output (not with PLC)	20...253 V AC, 50/60 Hz or 20...253 V DC	G 3/4"	Cable plug EN 175301-803	555296 🛒
		G 1"		555298 🛒
IO-Link	9.6...35 V DC	G 3/4"	Multipin male connector M12 x 1	572025 🛒
		NPT 3/4"		572026 🛒
		Clamp 1"		572027 🛒
		Clamp 2"		572028 🛒

DTS 1000079485 EN Version: O Status: RL (released | freigegeben | valide) printed: 18.12.2023

Further variants on request	
 <p>Process connection</p> <ul style="list-style-type: none"> • Clamp 1"; 1½" • DIN 11851 • SMS 	 <p>Hygienic Ra < 0.8 µm for G or NPT threaded connection</p>
 <p>Electrical connection Quick on connection (IP65)</p>	

8.4. Ordering chart accessories

Description	Article no.
M12 female connector with plastic threaded clamping ring, 5-pin, straight, to be wired	917116 
M12 female connector with moulded cable (shielded), 5-pin, straight, cable length: 2 m	438680 

DTS 1000079485 EN Version: O Status: RL (released | freigegeben | valide) printed: 18.12.2023