

GLM700ASB family

Tooth sensor module with integrated magnet

The sensor modules of the GLM700ASB-Ax family are designed for use with passive measurement scales. The modules combine a GiantMagnetoResistive (GMR) tooth sensor with an integrated bias magnet in a compact SMD housing, to reduce the design and assembly effort of the user. In addition, the integration of sensor and magnet provides a very high quality of the sensor signals.

Adapted to a variety of tooth pitches, the integrated GMR sensors apply the FixPitch technology. This means that the sensor chip is matched to a given tooth pitch.

In use with a ferromagnetic scale and a matching pitch, the module delivers two 90 degree phase shifted analogue signals (sine and cosine).

The table "Product overview" on page 7 shows the modules available with the according pitch.

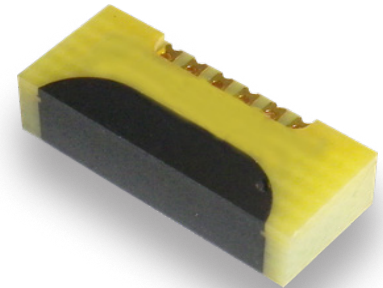

Product Overview

Article description	Package
GLM7xxASB-Ax ¹⁾	Module Combining a sensor and a magnet for a variety of tooth pitches with sine and cosine output signal.

¹⁾ For order information see page 7.

Quick Reference Guide

Symbol	Parameter	Min.	Typ.	Max.	Unit
V _{CC}	Supply voltage	-	5.0	-	V
V _{peak}	Signal amplitude per V _{CC} ²⁾	4.0	9.0	20.0	mV/V
T _{amb}	Ambient temperature	-40	-	+125	°C
f	Frequency range	1	-	-	MHz

²⁾ The amplitude depends on the distance between sensor and scale. For further information see fig. 6 (page 4).

Absolute Maximum Ratings

In accordance with the absolute maximum rating system (IEC60134).

Symbol	Parameter	Min.	Max.	Unit
V _{CC}	Supply voltage	-9.0	+9.0	V
T _{amb}	Ambient temperature	-40	+125	°C
T _{stg}	Storage temperature	-40	+125	°C
MSL	Moisture sensitivity level	2		

Stresses beyond those listed under "Absolute maximum ratings" may cause permanent damage to the device. This is a stress rating only and functional operation of the device at these or any other conditions beyond those indicated in the operational sections of this specification is not implied. Exposure to absolute maximum rating conditions for extended periods may affect device reliability.

Features

- Gear tooth sensor with integrated magnet
- Differential sine and cosine output signals
- Ambient temperature range from -40 °C to +125 °C
- Designed for vertical or horizontal mounting
- High signal quality due to FixPitch technology
- Contactless, wear-free measurement

Advantages

- Allows use of simple passive toothed structures as measurement scale; so reducing design, manufacturing and assembly effort
- Flexible design options due to identical pin arrangements
- Reliable operation in difficult environments
- High interpolation possible within tooth pitch for high resolution and high accuracy
- Minimal offset voltage
- Low power consumption for battery-driven applications

Applications

Incremental encoder for linear or rotary motion in various industrial applications, for example:

- Linear position measurement
- Linear and rotary bearings



ESD



Electrical Data

$T_{amb} = 25\text{ °C}$; unless otherwise specified.

Symbol	Parameter	Conditions	Min.	Typ.	Max.	Unit
V_{CC}	Supply voltage		-	5.0	-	V
TC_{RB}	Temperature coefficient of R_B and R_S ¹⁾	$T_{amb} = (-40\dots+125)\text{ °C}$	-	0.12	-	%/K
$TC_{V_{off}}$	Temperature coefficient of V_{off} ²⁾	$T_{amb} = (-40\dots+125)\text{ °C}$	-3.0	-	+3.0	$\mu\text{V}/\text{V}/\text{K}$
T_{amb}	Ambient temperature		-40	-	+125	°C
V_{peak}	Signal amplitude per V_{CC} ³⁾		4.0	9.0	20.0	mV/V
$TC_{V_{peak}}$	Temperature coefficient of V_{peak} ⁴⁾	$T_{amb} = (-40\dots+125)\text{ °C}$	-0.08	-0.12	-0.16	%/K
f	Frequency range ⁵⁾		1	-	-	MHz

$$^1) TC_R = 100 \cdot \frac{R(T_2) - R(T_1)}{R(T_{ref}) \cdot (T_2 - T_1)} \quad \text{with } T_1 = -40\text{ °C}, T_2 = +125\text{ °C} \quad \text{and } T_{ref} = +25\text{ °C}$$

$$^2) TC_{V_{off}} = 100 \cdot \frac{V_{off}(T_2) - V_{off}(T_1)}{T_2 - T_1} \quad \text{with } T_1 = -40\text{ °C}, T_2 = +125\text{ °C}$$

³⁾ The amplitude depends on the distance between sensor and scale. See Fig. 1 (page 4) for more information.

$$^4) TC_{V_{peak}} = 100 \cdot \frac{V_{peak}(T_2) - V_{peak}(T_1)}{V_{peak}(T_{amb}) \cdot (T_2 - T_1)} \quad \text{with } T_1 = +25\text{ °C}, T_2 = +125\text{ °C}$$

⁵⁾ No significant amplitude loss in this frequency range.

Product Type Specific Data

Article description	Pitch	Offset Voltage	Bridge resistance ⁶⁾	Sensor resistance ⁷⁾	Air gap ⁸⁾
GLM711ASB-Ax	1 mm	$\pm 3.0\text{ mV}/\text{V}$	5.5 k Ω	2.75 k Ω	200 μm
GLM712ASB-Ax	2 mm	$\pm 3.5\text{ mV}/\text{V}$	5.7 k Ω	2.85 k Ω	400 μm
GLM713ASB-Ax	3 mm	$\pm 3.5\text{ mV}/\text{V}$	5.7 k Ω	2.85 k Ω	600 μm
GLM714ASB-Ax	0.94 mm (module 0.3)	$\pm 3.0\text{ mV}/\text{V}$	5.6 k Ω	2.80 k Ω	190 μm
GLM715ASB-Ax	1.57 mm (module 0.5)	$\pm 3.0\text{ mV}/\text{V}$	5.8 k Ω	2.90 k Ω	310 μm

⁶⁾ Bridge resistance between pad 1 and 5, 2 and 6. Resistor tolerance $\pm 15\%$.

⁷⁾ Sensor resistance between pad 3 and 4. Resistor tolerance $\pm 15\%$.

⁸⁾ Optimal air gap between sensor and scale - for further information see Fig. 6 (page 4).

Additional Sensor Information

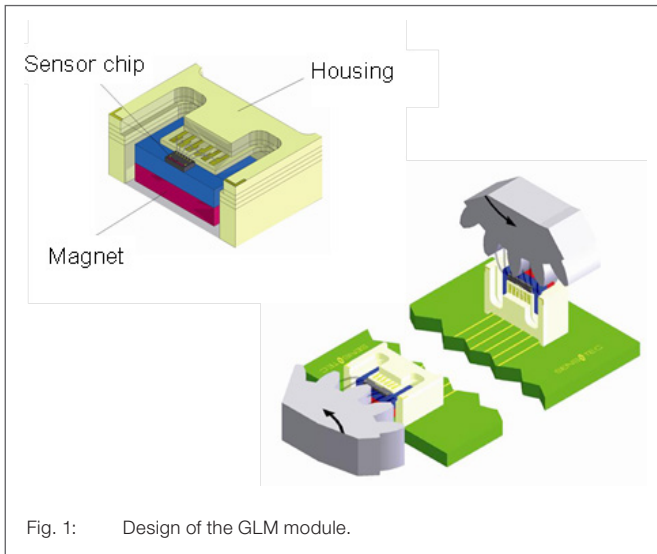

Fig. 1: Design of the GLM module.

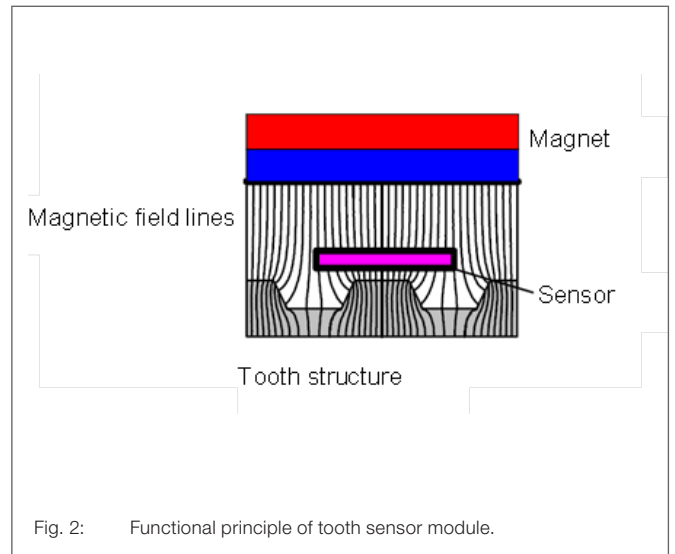

Fig. 2: Functional principle of tooth sensor module.

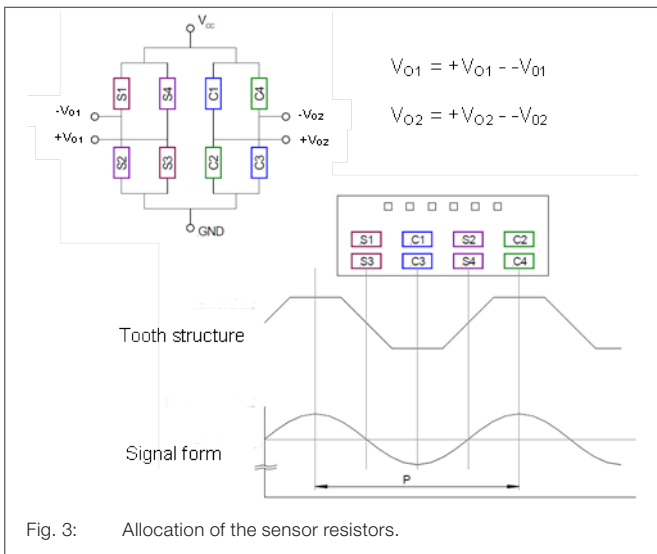

Fig. 3: Allocation of the sensor resistors.

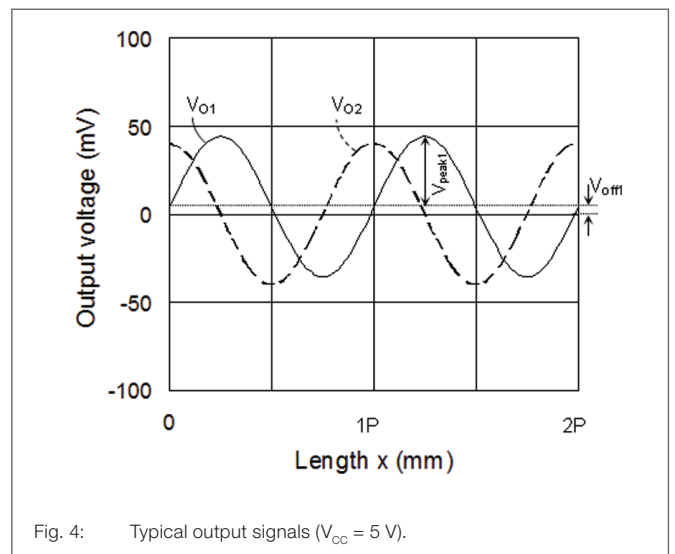

Fig. 4: Typical output signals ($V_{CC} = 5\text{ V}$).

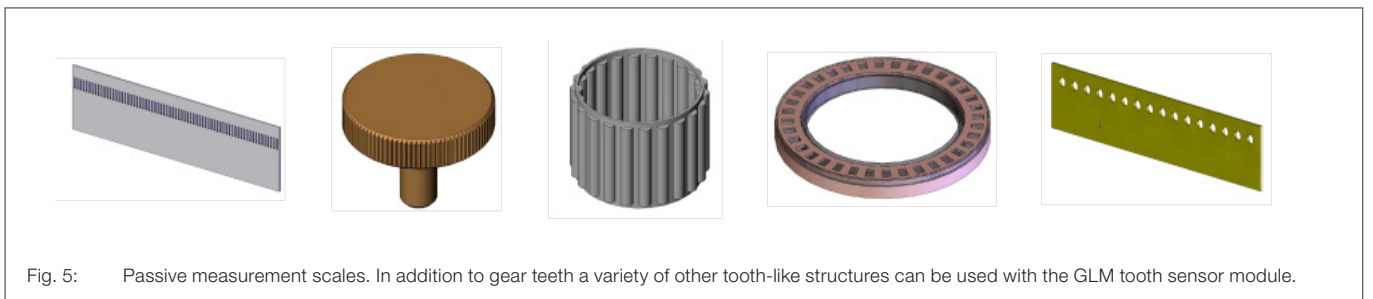

Fig. 5: Passive measurement scales. In addition to gear teeth a variety of other tooth-like structures can be used with the GLM tooth sensor module.

Module vs. Tooth Pitch

To calculate the modules or the tooth pitch you can use these formula:

$$m = \frac{d}{z} = \frac{p}{\pi}$$

m = module of the gearwheel
 d = reference diameter (in mm)
 z = number of teeth on the perimeter
 p = tooth pitch (in mm)

Typical Performance Graphs

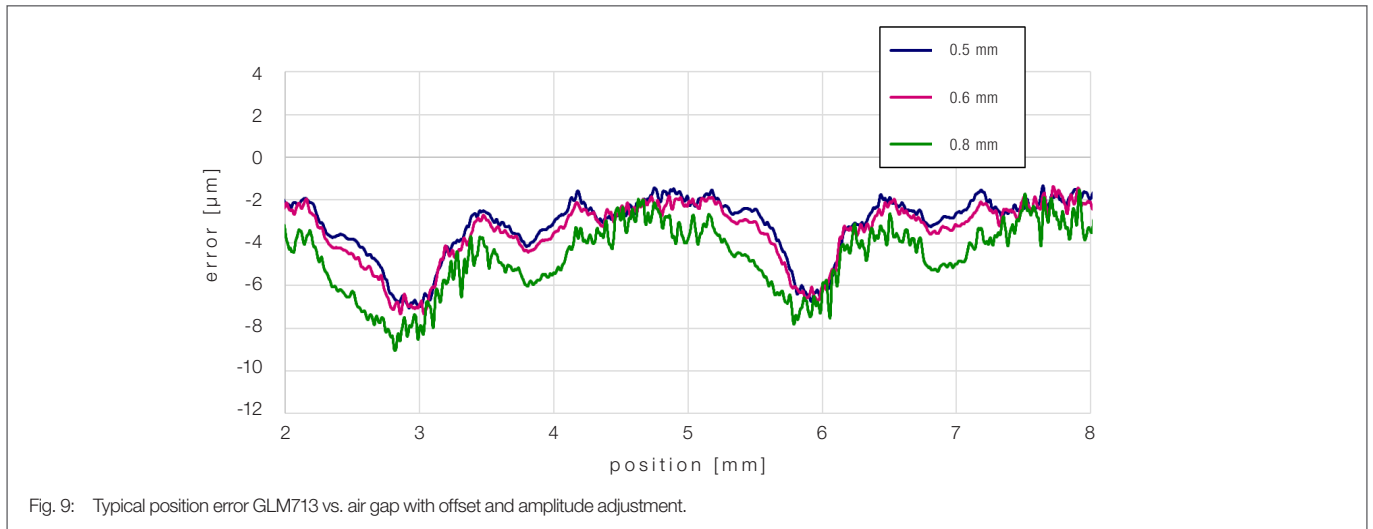
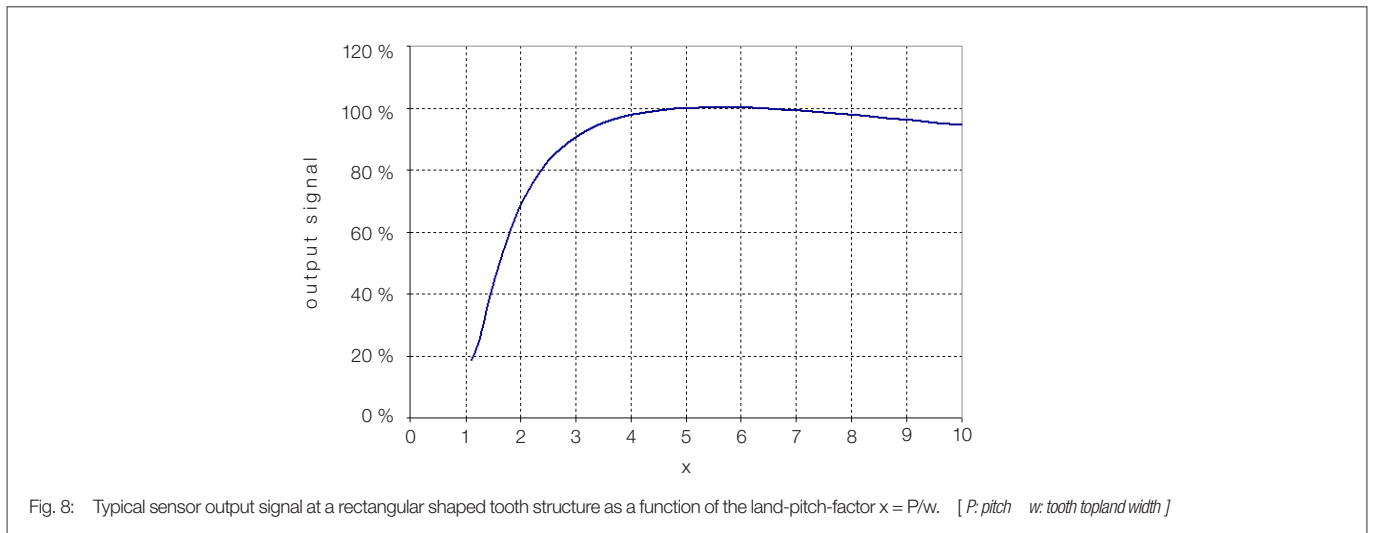
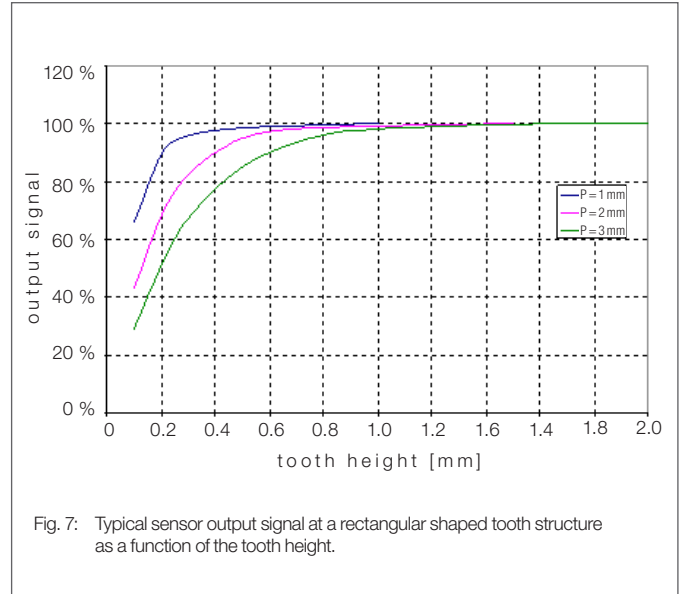
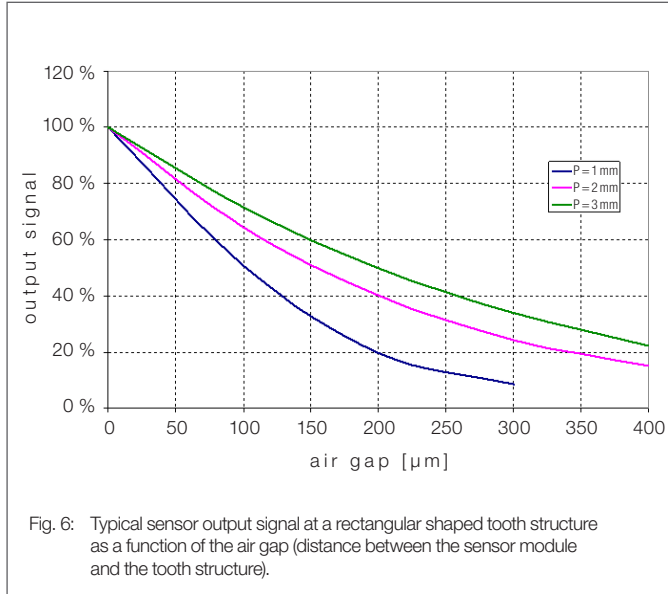

Pinning

Pad	Symbol	Parameter
1	+V _{O1}	Positive output voltage bridge 1
2	+V _{O2}	Positive output voltage bridge 2
3	V _{CC}	Supply voltage
4	GND	Ground
5	-V _{O1}	Negative output voltage bridge 1
6	-V _{O2}	Negative output voltage bridge 2

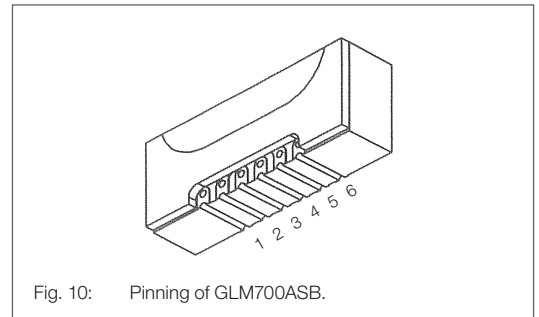

Fig. 10: Pinning of GLM700ASB.

Dimensions

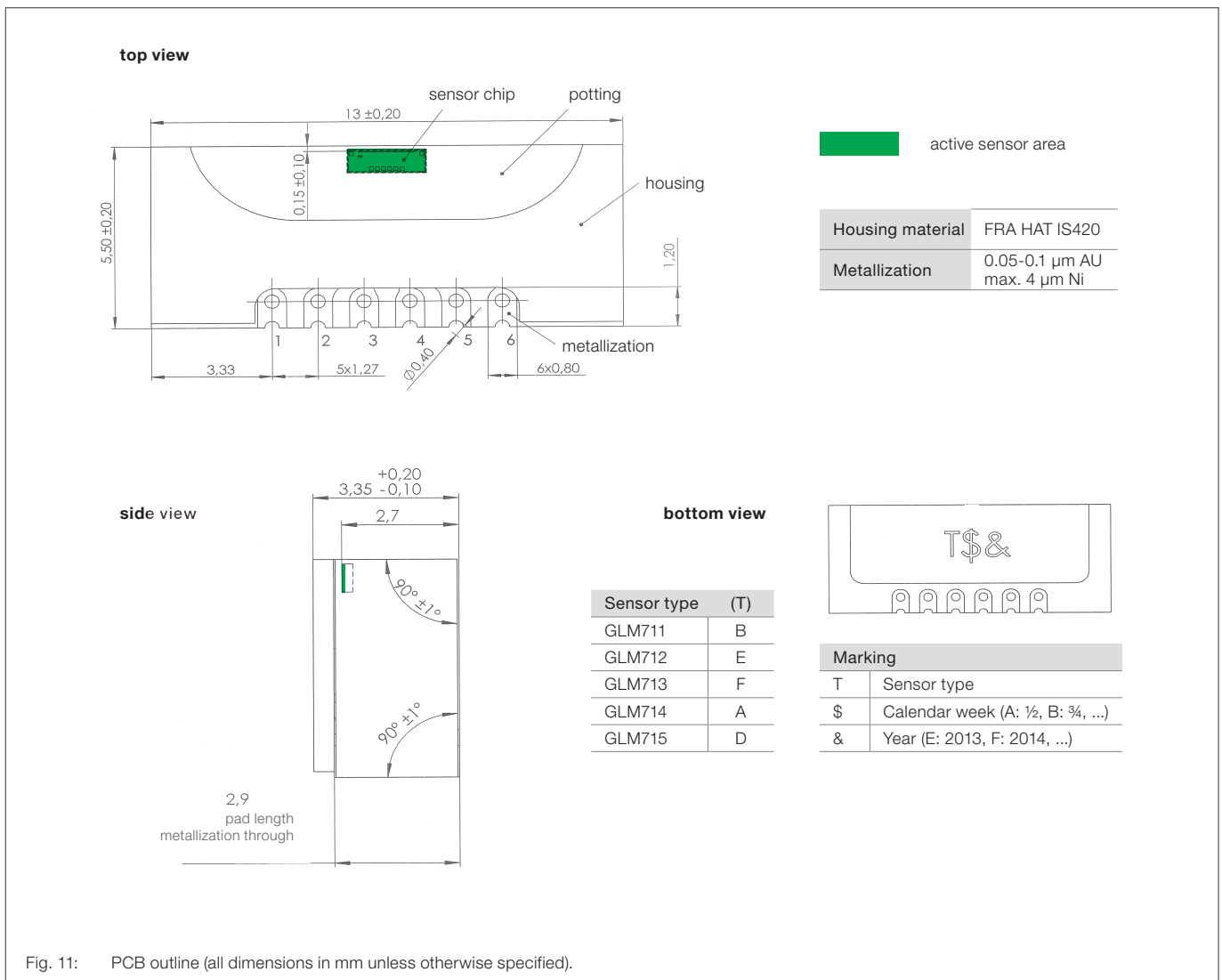
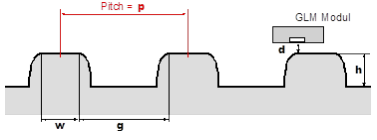
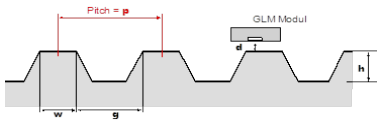
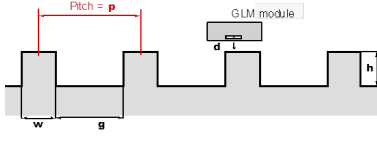
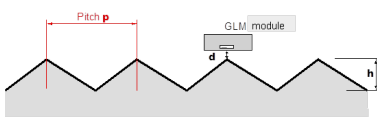

Fig. 11: PCB outline (all dimensions in mm unless otherwise specified).

Recommended tooth profiles	h tooth height	w tooth top land width	g tooth gap	d air gap	signal quality
	$\frac{IV}{4} p$	$\sim \frac{p}{3}$	$\sim \frac{2p}{3}$	$\sim \frac{p}{5}$	+++
	$\frac{IV}{4} p$	$\sim \frac{p}{3}$	$\sim \frac{2p}{3}$	$\sim \frac{p}{5}$	+++
	$\frac{IV}{4} p$	$\sim \frac{p}{3}$	$\sim \frac{2p}{3}$	$\sim \frac{p}{5}$	+++
	$\frac{IV}{3} p$	—	—	$\sim \frac{p}{5}$	++

Magnetically soft materials are to be used for the measurement scale, e. g.:

Material short designation	Material number according DIN 17007 T1
St37	(1.0037)
St44	(1.0044)
9SMnPb28	(1.0718)
9SMnPb29	(1.0737)
20MnV6	(1.5217)

Material short designation	Material number according DIN 17007 T1
X20Cr13	(1.4021)
X30Cr13	(1.4028)
X46Cr13	(1.4034)
X6Cr17	(1.4016)
X14CrMoS17	(1.4104)
X17CrNi16 2	(1.4057)
X39CrMo17 1	(1.4122)
X90CrMoV18	(1.4112)

The tooth gap can be filled by a chrome coating or by other non-ferromagnetic materials if the application requires a smooth surface. This table is intended only as a rough guide. Please contact your sales engineer for further details.

Purchased Parts Package and Delivery Form

Quantity	Part	Description
20	GLM7xxASB-AC	Waffle pack for horizontal mounting
120	GLM7xxASB-AH	Tray for vertical mounting

Order Code

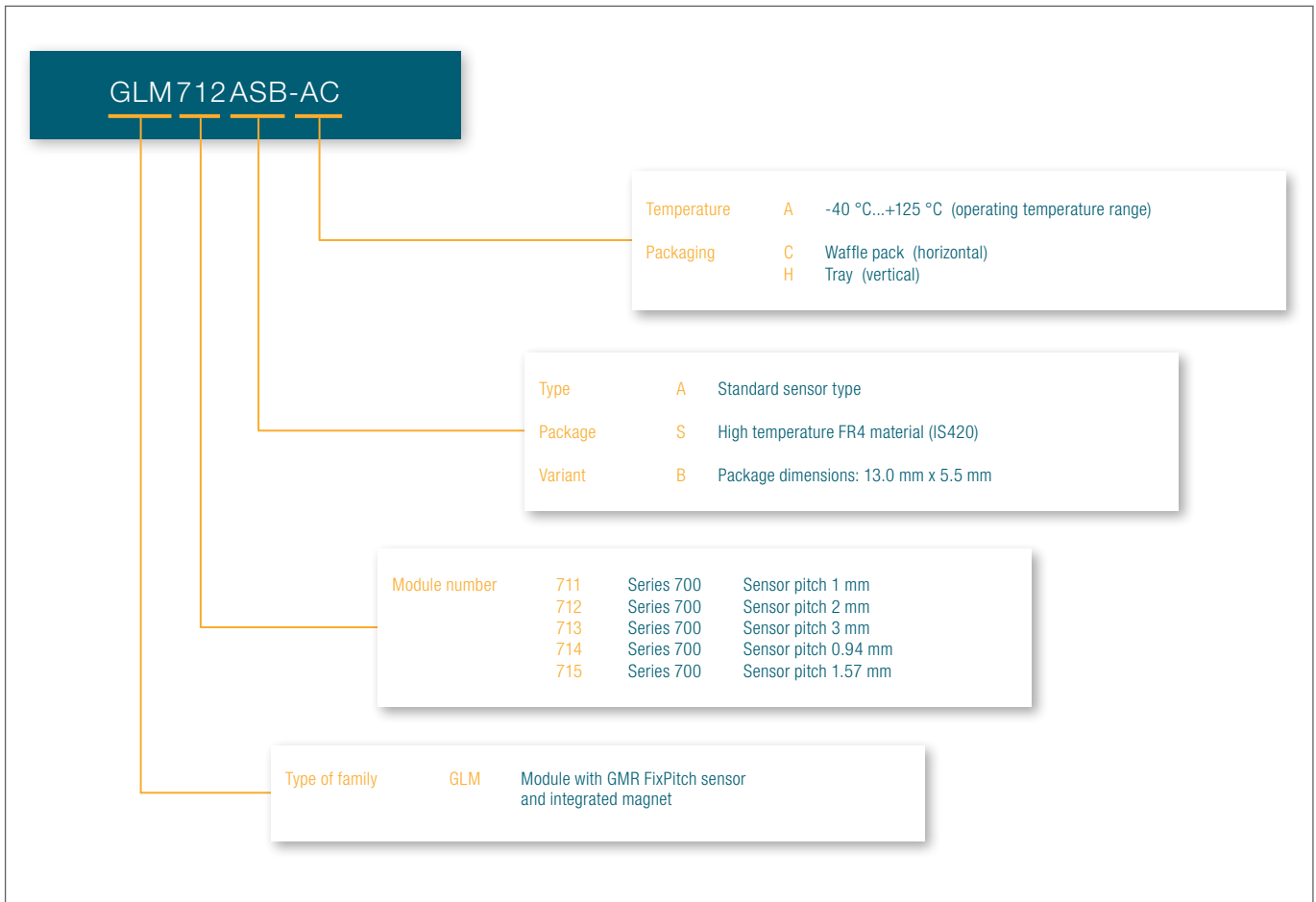

Product Overview

Article description	Pitch	Marking ¹⁾	Delivery form ²⁾	Article number
GLM711ASB-AC	1 mm	B\$&	Waffle Pack	5102.2211.2
GLM712ASB-AC	2 mm	E\$&	Waffle Pack	5102.2212.2
GLM713ASB-AC	3 mm	F\$&	Waffle Pack	5102.2213.2
GLM714ASB-AC	0.94 mm (module 0.3)	A\$&	Waffle Pack	5102.2214.2
GLM715ASB-AC	1.57 mm (module 0.5)	D\$&	Waffle Pack	5102.2215.2
GLM715ASB-AH	1.57 mm (module 0.5)	D\$&	Tray	5102.2225.1

¹⁾ \$ - calendar week (A:1/2, B:3/4, ...), & - Year (E:2013, F:2014, ...).

²⁾ The delivery form „Tray“ is used for the automatic vertical assembly of the GLM module.

Note: For all GLM700 types delivery form „Tray“ (for vertical mounting) is available on request.

Special Design Features



PerfectWave

Sensors with PerfectWave design provide the best signal quality, highest accuracy and optimal sensor linearity by filtering out higher harmonics in the signal. The linearity of the sensor is assured, even for weak magnetic field measurement.



FixPitch

FixPitch sensors are adapted to the pole length (pitch) of the measurement scale. The linearity of the sensor is optimized and the influence of interference fields is minimized.

General Information

Product Status

Article	Status
GLM7xxASB-Ax	The product is in series production.
Note	The status of the product may have changed since this data sheet was published. The latest information is available on the internet at www.sensitec.com .

Disclaimer

Sensitec GmbH reserves the right to make changes, without notice, in the products, including software, described or contained herein in order to improve design and/or performance. Information in this document is believed to be accurate and reliable. However, Sensitec GmbH does not give any representations or warranties, expressed or implied, as to the accuracy or completeness of such information and shall have no liability for the consequences of use of such information. Sensitec GmbH takes no responsibility for the content in this document if provided by an information source outside of Sensitec products.

In no event shall Sensitec GmbH be liable for any indirect, incidental, punitive, special or consequential damages (including but not limited to lost profits, lost savings, business interruption, costs related to the removal or replacement of any products or rework charges) irrespective the legal base the claims are based on, including but not limited to tort (including negligence), warranty, breach of contract, equity or any other legal theory.

Notwithstanding any damages that customer might incur for any reason whatsoever, Sensitec product aggregate and cumulative liability towards customer for the products described herein shall be limited in accordance with the General Terms and Conditions of Sale of Sensitec GmbH. Nothing in this document may be interpreted or construed as an offer to sell products that is open for acceptance or the grant, conveyance or implication of any license under any copyrights, patents or other industrial or intellectual property rights.

Unless otherwise agreed upon in an individual agreement Sensitec products sold are subject to the General Terms and Conditions of Sales as published at www.sensitec.com.

Sensitec GmbH

Georg-Ohm-Str. 11 · 35633 Lahnau · Germany
Tel. +49 6441 9788-0 · Fax +49 6441 9788-17
www.sensitec.com · sensitec@sensitec.com

General Information

Application Information

Applications that are described herein for any of these products are for illustrative purposes only. Sensitec GmbH makes no representation or warranty – whether expressed or implied – that such applications will be suitable for the specified use without further testing or modification.

Customers are responsible for the design and operation of their applications and products using Sensitec products, and Sensitec GmbH accepts no liability for any assistance with applications or customer product design. It is customer's sole responsibility to determine whether the Sensitec product is suitable and fit for the customer's applications and products planned, as well as for the planned application and use of customer's third party customer(s). Customers should provide appropriate design and operating safeguards to minimize the risks associated with their applications and products.

Sensitec GmbH does not accept any liability related to any default, damage, costs or problem which is based on any weakness or default in the customer's applications or products, or the application or use by customer's third party customer(s). Customer is responsible for doing all necessary testing for the customer's applications and products using Sensitec products in order to avoid a default of the applications and the products or of the application or use by customer's third party customer(s).

Sensitec does not accept any liability in this respect.

Life Critical Applications

These products are not qualified for use in life support appliances, aeronautical applications or devices or systems where malfunction of these products can reasonably be expected to result in personal injury.

Copyright © 2019 by Sensitec GmbH, Germany

All rights reserved. No part of this document may be copied or reproduced in any form or by any means without the prior written agreement of the copyright owner. The information in this document is subject to change without notice. Please observe that typical values cannot be guaranteed. Sensitec GmbH does not assume any liability for any consequence of its use.

Sensitec GmbH

Georg-Ohm-Str. 11 · 35633 Lahnau · Germany
Tel. +49 6441 9788-0 · Fax +49 6441 9788-17
www.sensitec.com · sensitec@sensitec.com