

## Electronic Measuring Relays

### Measuring relays for AC/DC voltages / over- and undervoltages

---



#### Measuring relays for AC/DC voltages

Type AUN1/510ca - 1.60 - (Uv)      Ref. no 16.28-01

Type AUN1/511cq - 1.60 - (Uv)      Ref. no 16.28-02

#### Task

Monitors voltages of AC or DC circuits for exceeding or falling below an adjustable treshold S.

#### Use

Monitor for dry and storage batteries, emergency power sources, solar generators; monitoring electrical drives for standstill.

#### Range extensions

Voltages exceeding 300 V with series resistor at terminal 1 (3.67 k $\Omega$  per 1 V range extension).

#### Hysteresis H and times X, Y and Z

Version /510ca: H fixed 5 % of S, no times.

Version /511cq: H adjustable 5 ... 50 % of S, start time delay X adjustable up to approx. 5 s, pull-in delay Y and dropout delay Z adjustable together up to approx. 0.5 s.

See catalog pages 2.1.1 and 2.1.2

#### Measuring relays for over- and undervoltages

Type AUNF1/510ca - 1.60 - (Uv)      Ref. no 16.28-03

Type AUNF1/510cq - 1.60 - (Uv)      Ref. no 16.28-04

#### Task

Monitors over- and undervoltages of AC/DC circuits by using a window comparator.

#### Use

Monitor for dry and storage batteries, emergency power sources, solar generators; monitoring electrical drives for standstill.

#### Range extensions

Voltages exceeding 300 V with series resistor at terminal1 (3.67 k $\Omega$  per 1 V range extension).

#### Hysteresis H and times X, Y and Z

Version /510ca: H fixed 5 % of S, no times.

Version /510cq: H fixed 5 % of S, start time delay X adjustable up to approx. 5 s, pull-in delay Y and dropout delay Z adjustable together up to approx. 0.5 s.

See catalog pages 2.1.3 and 2.1.4

### Measuring relays for AC/DC voltages

Type	Ref. no.	Page	Voltage range	Operating voltage $U_V$	Version
AUN1/510ca - 1.60 - 42VAC	16.28-01-003	2.1.1	4 mV ... 300 V	42 V AC	threshold adjustable, H fixed, no times
AUN1/510ca - 1.60 - 24VAC	16.28-01-005	2.1.1	4 mV ... 300 V	24 V AC	threshold adjustable, H fixed, no times
AUN1/510ca - 1.60 - 115/230VAC	16.28-01-007	2.1.1	4 mV ... 300 V	115 / 230 V AC	threshold adjustable, H fixed, no times
AUN1/511cq - 1.60 - 42VAC	16.28-02-003	2.1.2	4 mV ... 300 V	42 V AC	threshold adjustable, H adjustable
AUN1/511cq - 1.60 - 24VAC	16.28-02-005	2.1.2	4 mV ... 300 V	24 V AC	threshold adjustable, H adjustable
AUN1/511cq - 1.60 - 115/230VAC	16.28-02-007	2.1.2	4 mV ... 300 V	115 / 230 V AC	threshold adjustable, H adjustable

### Measuring relays for over- and undervoltages

Type	Ref. no.	Page	Voltage range	Operating voltage $U_V$	Version
AUNF1/510ca - 1.60 - 42VAC	16.28-03-003	2.1.3	4 mV ... 300 V	42 V AC	threshold adjustable, H fixed, no times
AUNF1/510ca - 1.60 - 24VAC	16.28-03-005	2.1.3	4 mV ... 300 V	24 V AC	threshold adjustable, H fixed, no times
AUNF1/510ca - 1.60 - 115/230VAC	16.28-03-007	2.1.3	4 mV ... 300 V	115 / 230 V AC	threshold adjustable, H fixed, no times
AUNF1/510cq - 1.60 - 42VAC	16.28-04-003	2.1.4	4 mV ... 300 V	42 V AC	threshold adjustable, H fixed
AUNF1/510cq - 1.60 - 24VAC	16.28-04-005	2.1.4	4 mV ... 300 V	24 V AC	threshold adjustable, H fixed
AUNF1/510cq - 1.60 - 115/230VAC	16.28-04-007	2.1.4	4 mV ... 300 V	115 / 230 V AC	threshold adjustable, H fixed

# Electronic Measuring Relays

## AUN measuring relays for AC/DC voltages

<b>Device</b>	measuring relay for AC and DC voltages
For the exact type designation and ref. no. please see page 2.0.2	<b>AUN1/510ca-1.60 - (Uv)</b> 16.28-01-xxx

Technical data	
Line voltage Uv	please indicate when ordering
Alternating voltage	230 / 115, 42, 24 V AC
Tolerance	± 10 %
Frequency	50 ... 60 Hz
Operating temperature	0 ... + 60 °C
Power consumption	approx. 4 VA
Housing	60 (page 0.0.1)
Weight	approx. 300 g
(see table) Input (E)	5 voltage ranges selectable
Output	
Relay output	1 changeover switch
Switching voltage	24 ... 250 V AC or DC
Switching current	0.05 ... 6 A
Switching capacity for AC	max. 1250 VA
Switching capacity for DC	max. 50 W
Switching frequency	max. 5000 / h
Switching cycles	30 x 10 <sup>6</sup>
Response times	
Exceeding threshold / falling below threshold	approx. 25 ms / approx. 100 ms
Indicators	
1 green LED	Power ON
1 red LED	Relay pulled-in
Accuracy	
Setting accuracy	± 5 %
Repeatability	± 0.5 %
Temperature dependence	± 0.1 % / °C
Operation mode	
a Overvoltage monitor	without bridge B between the terminals 6-7 the relay drops out when exceeding treshold S
b Undervoltage monitor	with bridge B between the terminals 6-7 the relay pulls in when exceeding treshold S
Hysteresis (H)	fixed 5 % of S, no times

For general description see catalog page 2.0.1

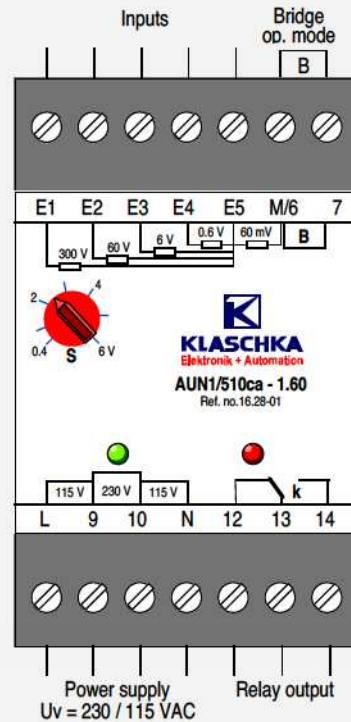

Input	Range	Input resistance	Overload capability	
			continuous	3 s, 5 % DF
E1	20 ... 300 V	1 MΩ	400 V	400 V
E2	4 ... 60 V	220 kΩ	250 V	330 V
E3	0.4 ... 6 V	22 kΩ	80 V	100 V
E4	40 ... 600 mV	2.2 kΩ	25 V	33 V
E5	4 ... 60 mV	220 Ω	8 V	10 V

### Diagram

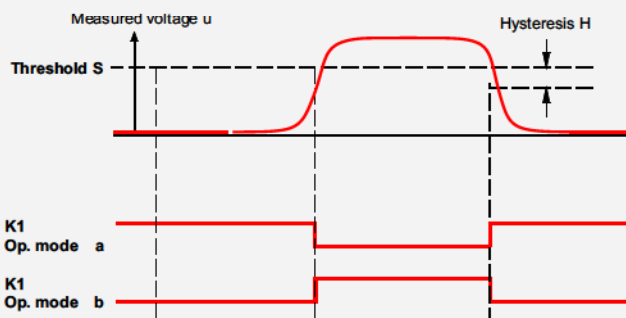

### Wiring

AC/DC 2-pole

AC and DC voltage measuring relay with LED display

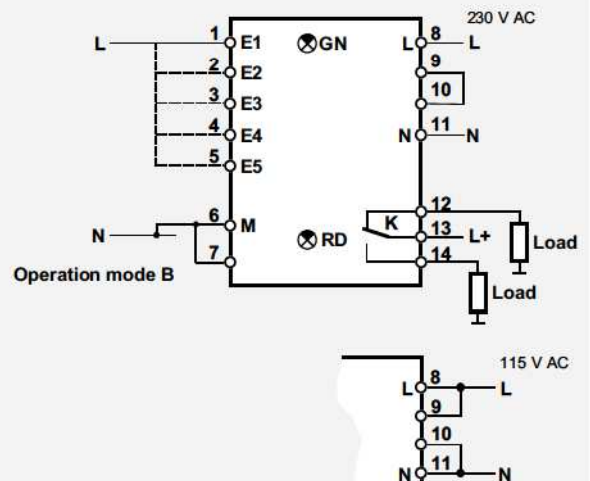

# AUN measuring relays for AC and DC voltages

<b>Device</b>	measuring relay for AC and DC voltages
For the exact type designation and ref. no. please see page 2.0.2	<b>AUN1/511cq-1.60 - (Uv)</b> 16.28-02-xxx

Technical data	
Line voltage Uv	please indicate when ordering
Alternating voltage	230 / 115, 42, 24 V AC
Tolerance	± 10 %
Frequency	50 ... 60 Hz
Operating temperature	0 ... + 60 °C
Power consumption	approx. 4 VA
Housing	60 (page 0.0.1)
Weight	approx. 300 g
(see table) input (E)	5 voltage ranges selectable
Output	
Relay output	1 changeover switch
Switching voltage	24 ... 250 V AC or DC
Switching current	0.05 ... 6 A
Switching capability, AC	max. 1.250 VA
Switching capability, DC	max. 50 W
Switching frequency	max. 5000 / h
Switching cycles	30 x 10 <sup>6</sup>
Time delays	
Exceeding threshold / falling below threshold	approx. 25 ms / approx. 100 ms
Indicators	
1 LED green	Power ON
1 LED yellow	Relay pulled-in
Accuracy	
Setting accuracy	± 5 %
Repeatability	± 0.5 %
Temperature dependence	± 0.1 % / °C
Operation mode	
a Overvoltage monitor	without bridge B between the terminals 6-7 the relay drops out when exceeding treshhold S
b Undervoltage monitor	with bridge B between the terminals 6-7 the relay pulls in when exceeding treshhold S
Hysteresis (H)	adjustable 5 ... 50 % of S
Start time delay (X)	adjustable up to approx. 5 s
Pull-in (Y) / dropout delay (Z)	adjust. together up to approx. 0.5 s

For general description see catalog page 2.0.1

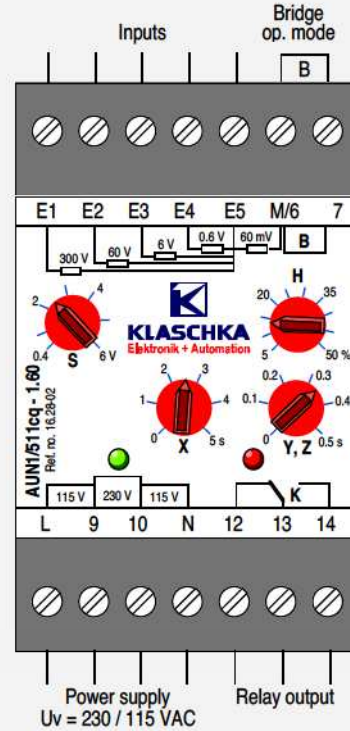

Input	Range	Input resistance	Overload capability	
			continuous	3 s, 5 % DF
E1	20 ... 300 V	1 MΩ	400 V	400 V
E2	4 ... 60 V	220 kΩ	250 V	330 V
E3	0.4 ... 6 V	22 kΩ	80 V	100 V
E4	40 ... 600 mV	2.2 kΩ	25 V	33 V
E5	4 ... 60 mV	220 Ω	8 V	10 V

### Diagram

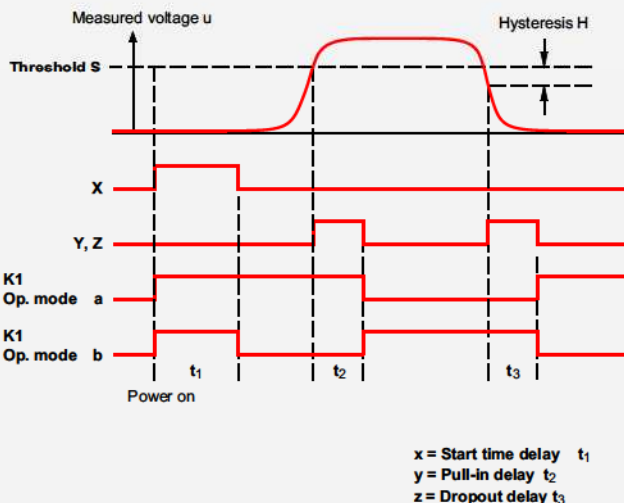

### Wiring

AC/DC 2-pole

AC and DC voltage measuring relay with LED display

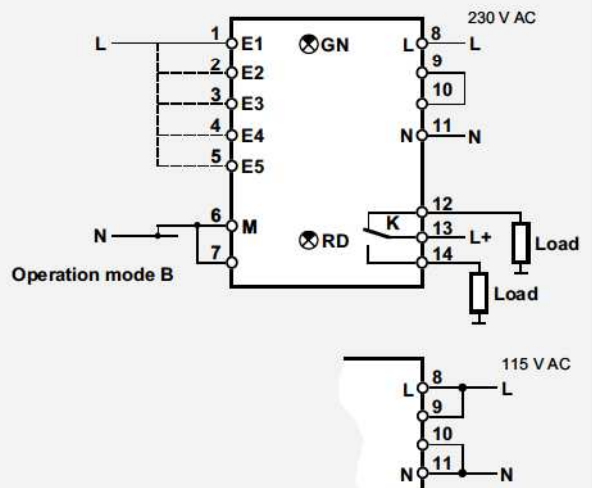

# Electronic Measuring Relays

## AUNF measuring relays for over- and undervoltages

<b>Device</b>	<b>AUNF measuring relay for over- and undervoltages</b>
For the exact type designation and ref. no. please see page 2.0.2	<b>AUNF1/510ca-1.60 - (Uv)</b> 16.28-03-xxx

Technical data	
Line voltage U <sub>v</sub>	please indicate when ordering
Alternating voltage	230 / 115, 42, 24 V AC
Tolerance / frequency	± 10 % / 50 ... 60 Hz
Operating temperature	0 ... + 60 °C
Power consumption	approx. 4 VA
Housing	.60 (page 0.0.1)
Weight	approx. 300 g
<b>(see table) Input (E)</b> 5 voltage ranges selectable	
Output	
Relay output	1 changeover switch
Switching voltage	24 ... 250 V AC or DC
Switching current	0.05 ... 6 A
Switching capacity, AC	max. 1250 VA
Switching capacity, DC	max. 50 W
Switching frequency / switching cycles	max. 5000 / h / 30 x 10 <sup>6</sup>
Response times	
Exceeding threshold / falling below threshold	approx. 25 ms / approx. 100 ms
Indicators	
1 green LED	Power ON
1 red LED	Relay pulled-in
Accuracy	
Setting accuracy	± 5 %
Repeatability	± 0.5 %
Temperature dependence	± 0.1 % / °C
Operation mode	
a	without wire bridge B between the terminals 6-7 the relay drops out when exceeding the low threshold S and pulls-in again when exceeding the high one.
b	without wire bridge B between the terminals 6-7 the relay pulls-in when exceeding the low threshold S and drops out again when exceeding the high one.
Hysteresis (H)	fixed 5 % of S, no times

For general description see catalog page 2.0.1

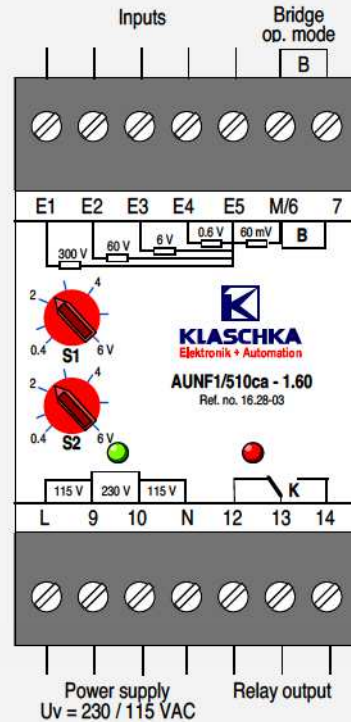

Input	Range	Input resistance	Overload capability	
			continuous	3 s, 5 % DF
E1	20 ... 300 V	1.1 MΩ	400 V	400 V
E2	4 ... 60 V	220 kΩ	250 V	330 V
E3	0.4 ... 6 V	22 kΩ	80 V	100 V
E4	40 ... 600 mV	2.2 kΩ	25 V	33 V
E5	4 ... 60 mV	220 Ω	8 V	10 V

### Pulse diagram

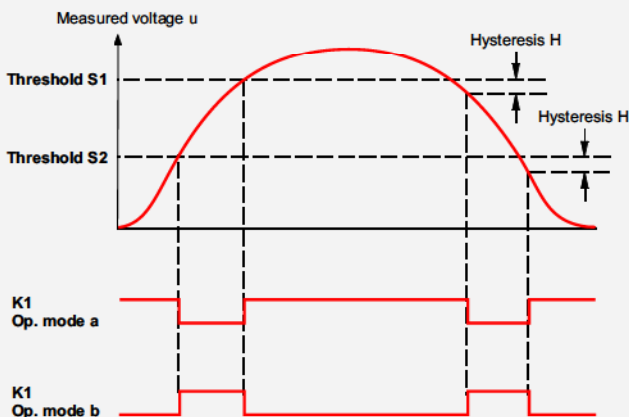

### Wiring

AC/DC 2-pole

### AC and DC voltage measuring relay

with LED display

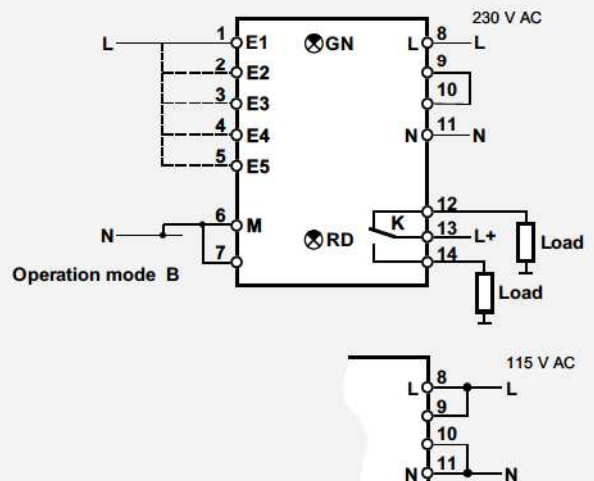

Device	AUNF measuring relay for over- and undervoltages
For the exact type designation and ref. no. please see page 2.0.2	AUNF1/510cq-1.60 - (Uv) 16.28-04-xxx

Technical data	
Line voltage Uv	please indicate when ordering
Alternating voltage	230 / 115, 42, 24 V AC
Tolerance / frequency	± 10 % / 50 ... 60 Hz
Operating temperature / power consumption	0 ... + 60 °C / approx. 4 VA
Housing	.60 (page 0.0.1)
Weight	approx. 300 g
(see table) Input (E)	5 voltage ranges selectable
Output	
Relay output	1 changeover switch
Switching voltage	24 ... 250 V AC or DC
Switching current	0.05 ... 6 A
Switching capability AC / switch. capability DC	max. 1.250 VA / max. 50 W
Switching frequency / switching cycles	max. 5000 / h / 30 x 10 <sup>6</sup>
Response times	
Exceeding threshold / falling below threshold	approx. 25 ms / approx. 100 ms
Indicators	
1 LED green	Power ON
1 LED yellow	Relay pulled-in
Accuracy	
Setting accuracy	± 5 %
Repeatability	± 0.5 %
Temperature dependence	± 0.1 % / °C
Operation mode	
a	without wire bridge B between the terminals 6-7 the relay drops out when exceeding the low threshold S and pulls-in again when exceeding the high one.
b	without wire bridge B between the terminals 6-7 the relay pulls-in when exceeding the low threshold S and drops out again when exceeding the high one.
Hysteresis (H)	adjustable 5 % of S
Start time delay (X)	adjustable up to approx. 5 s
Pull-in (Y) / dropout delay (Z)	adjust. together up to approx. 0.5 s

For general description see catalog page 2.0.1

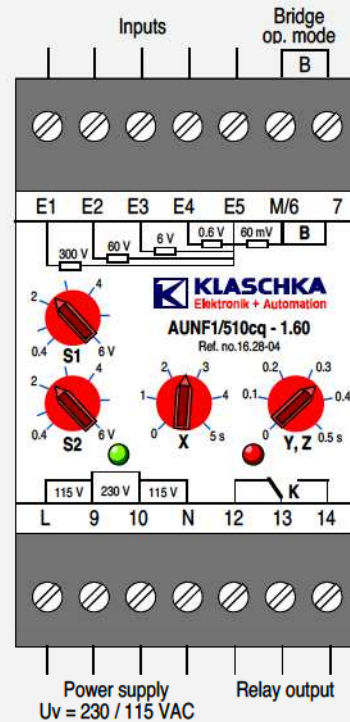

Input	Range	Input resistance	Overload capability	
			continuous	3 s, 5 % DF
E1	20 ... 300 V	1.1 MΩ	400 V	400 V
E2	4 ... 60 V	220 kΩ	250 V	330 V
E3	0.4 ... 6 V	22 kΩ	80 V	100 V
E4	40 ... 600 mV	2.2 kΩ	25 V	33 V
E5	4 ... 60 mV	220 Ω	8 V	10 V

### Pulse diagram

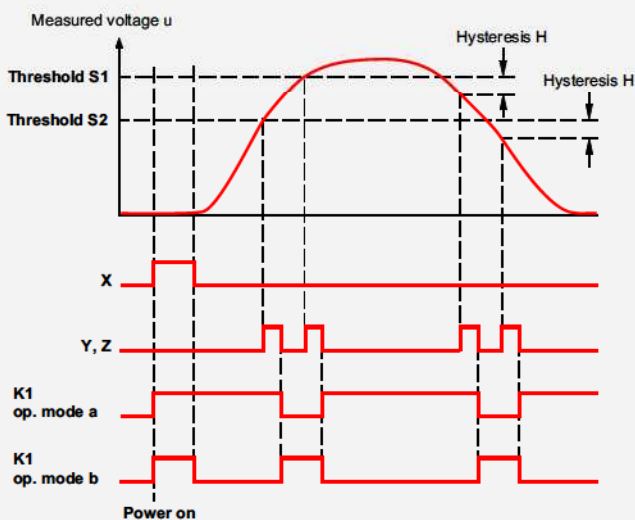

### Wiring

AC/DC 2-pole

### AC and DC voltage measuring relay with LED display

