

REVISION		DATE	BY	APPROVED
REV	DESCRIPTION			
A	PROTOTYPE			

MOTOR LEADS 22 AWG, TEFLON 17
13" ± 1" LONG

COLOR FUNCTION
RED MOTOR (+)
BLACK MOTOR (-)
STRIP BACK LEADS .3" ± .1"

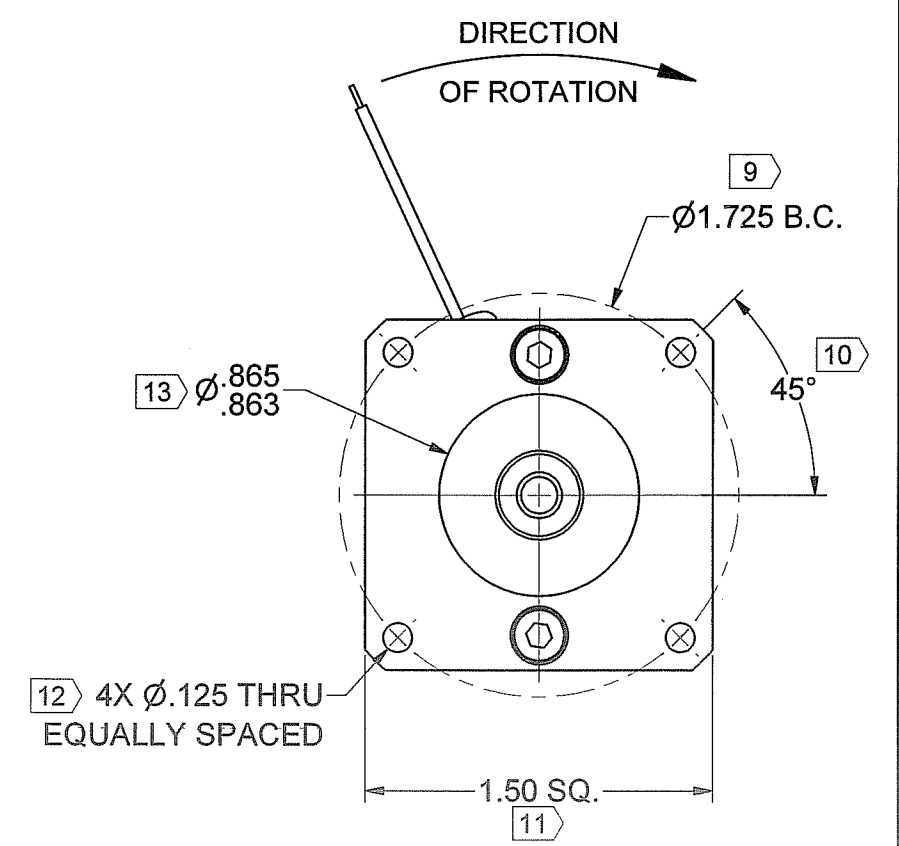
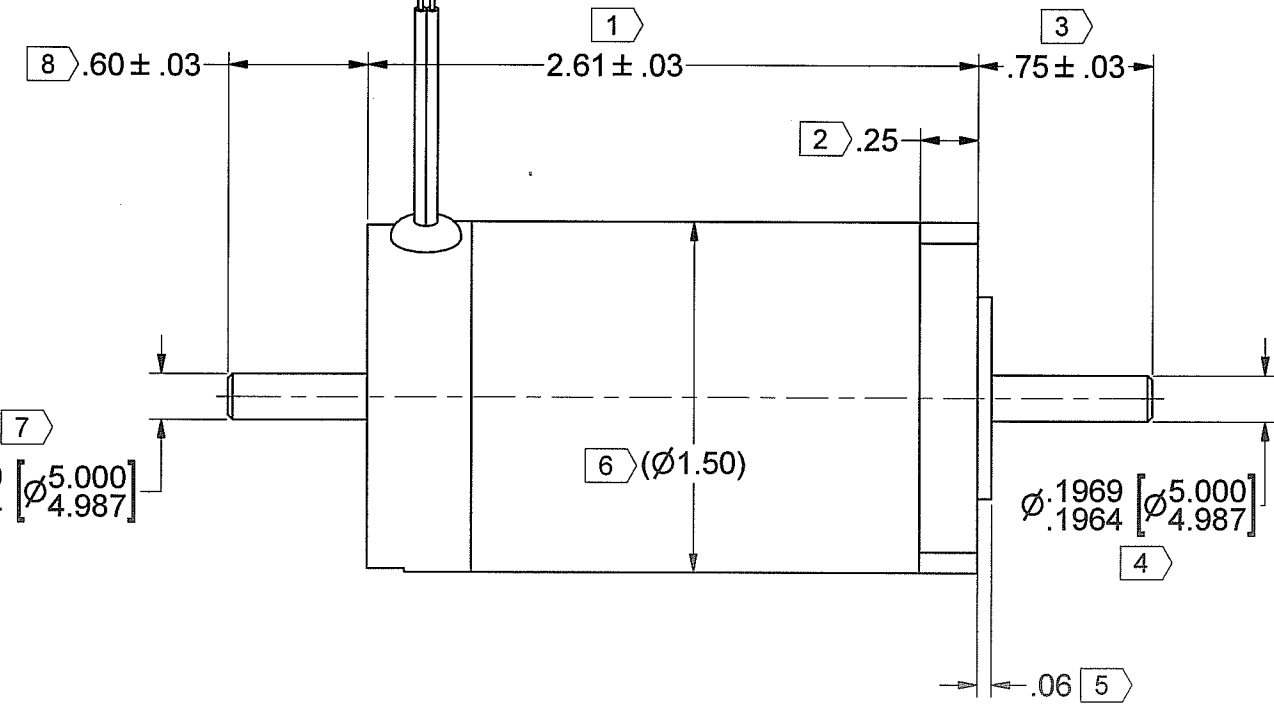
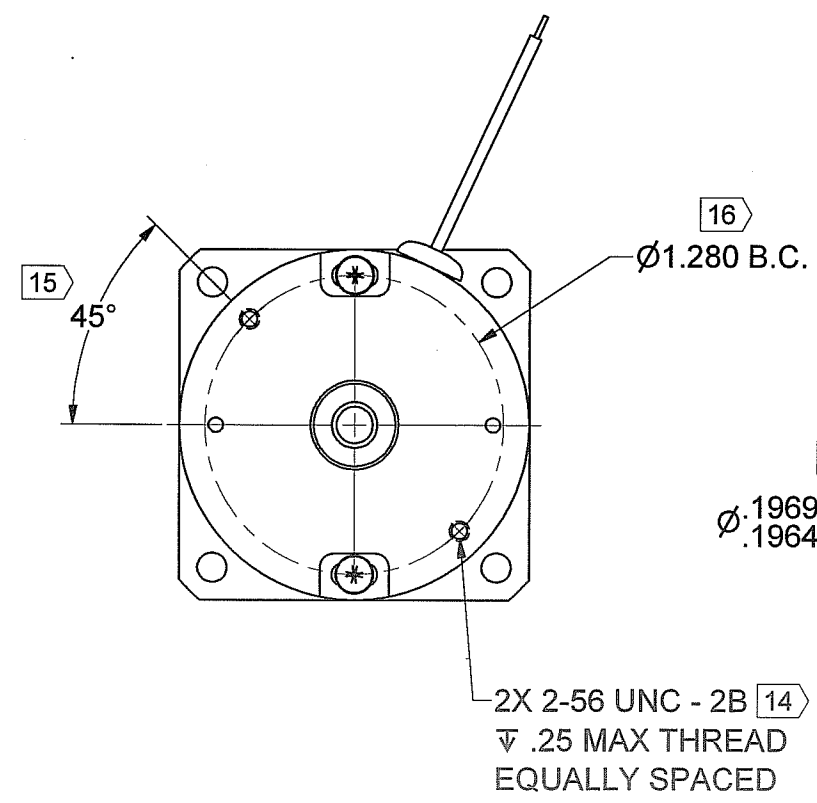

MOTOR SPECIFICATIONS:

TORQUE CONSTANT (Kt) = 5.20 ± 10% OZ-IN/AMP
VOLTAGE CONSTANT (Ke) = 3.85 ± 10% VOLTS/KRPM

NOTES:

- MOTOR ROTATION IS CLOCKWISE WHEN VIEWED FROM OUTPUT SHAFT WITH POSITIVE VOLTAGE APPLIED TO RED LEAD.
- SCREW PENETRATION NOT TO EXCEED SPECIFIED THREAD DEPTH
- X IDENTIFIES INSPECTION DIMENSIONS.

CONTROLLED
JUL 26 2022
DOCUMENT

UNLESS OTHERWISE SPECIFIED DIMENSIONS ARE IN INCHES & [mm]		THIRD ANGLE PROJECTION DO NOT SCALE DRAWING		THE INFORMATION CONTAINED IN THIS DRAWING IS THE SOLE PROPERTY OF MAGMOTOR TECHNOLOGIES. ANY REPRODUCTION OR DISCLOSURE OF THE INFORMATION CONTAINED THEREIN IN PART OR AS A WHOLE WITHOUT THE WRITTEN PERMISSION FROM MAGMOTOR TECHNOLOGIES IS PROHIBITED.		MAGMOTOR™	
TOLERANCES ON: ANGLES = ± 1/2° X.XX [X.X] = ± .01 [0.25] X.XXX [X.XX] = ± .005 [0.12]		SIGNATURES		DATE		TITLE	
-		DRAWN CGW		7/21/2022		MOTOR ASSEMBLY, SR15-O-100FX	
SPEC		CHECKED <i>sh</i>		7/21/22			
FINISH		ENG APPR. <i>mm</i>		7/21/22			
NONE		MFG APPR.		Q.A.		SIZE NUMBER	
SPEC		UNLESS OTHERWISE SPECIFIED REMOVE ALL BURRS & SHARP EDGES. COUNTERSINK TAPPED HOLES TO BODY SIZE. FILLETS: .03 MAX. / EXTERNAL CORNERS: .015 MAX.		D 500150064		REV A	
		SCALE: -		WEIGHT: -LB.		SHEET 1 OF 3	



10 Coppage Drive
Worcester, MA 01603
8/22/2022

MOTOR PERFORMANCE / SPECIFICATIONS

Attn.:

Final Product No.: **SR15-O-100FX**

Customer:

RFQ 500150064

Phone/Fax:

By: MM

Date: 8/22/2022

This is a calculation data sheet

SPECS	C/S	Frame	PM	-	Winding	-	Stack	Options	Gear Ratio
MODEL #	SR	15	-	-	O	-	100	FX	

V in =*	12 Vdc		Input Voltage	Eff = 0.9
Ke =*	3.85 V/krpm		Voltage Constant	
Kt =	5.2 oz-in/A		Torque Constant	
Rt =*	3.10 Ohms(@20° C)		Terminal Resistance+Amplifier	
Io =*	0.38 Amps		No load current	
I as =	3.9 Amps		Stall Current (reference only)	
T gs =	20 oz-in		Stall Torque (reference only @ V in)	
I 1 =	1.9 Amps		Current @ Torque-1	
I 2 =	2.9 Amps		Current @ Torque-2	
T 1 =*	8 oz-in		Torque-1	
T 2 =*	13 oz-in		Torque-2	
RPM nl =	3117 RPM		No Load Velocity	
RPM r =	1880 RPM		RPM @ T1	
RPM p =	1107 RPM		RPM @ T2	
R ah =	4.06 Ohms(@105° C)		Term. Resistance Hot	
T gsh =	15 oz-in		Stall Torque Hot	
I ash =	3.0 Amps		Stall Current Hot	
R th =*	6.5 °C/W		Thermal Resistance	
Tr =	77 °C	Without cooling air	Temperature Rise @ T1 (above ambient)	
Tr =	155 °C	Without cooling air	Temperature Rise @ T2 (above ambient)	
Nm/A =	0.04		Torque Constant	
Lb in/A =	0.33		Torque Constant	
Km =	3.0	Kt/r	Motor Constant	

Torque Curve

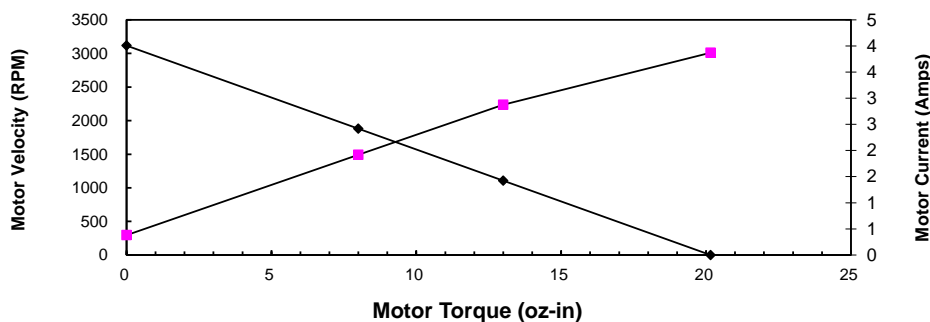

Calculation data

Voltage	Torque	RPM	Amp	Efficiency	Watts out
12	0	3117	0.4		0
12	8	1880	1.9	0.483642471	11.122636
12	13	1107	2.9	0.308200514	10.639441
12	20	0	3.9		0