



Centrifuge KM 50

Fully Jacketed Centrifuge for Separation of Solids from Liquids



Centrifuge KM 50

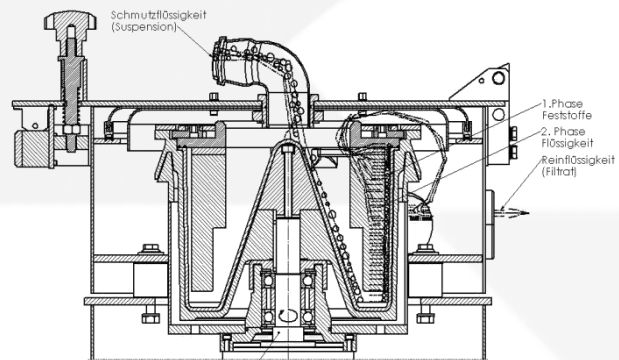

Operational Principle of KM 50

Technical Data	
continuous liquid throughput	max. 50 l/min. water/emulsion
rotor capacity	4,5 dm ³
solids capacity	3,0 dm ³
rotor speed	2.850 rpm 50 Hz / 3.420 rpm 60 Hz
separating factor	1000 g (g = gravity acceleration) 50 Hz / 1.100 g 60 Hz
drive	direct drive
drive power	1,0 kW 50 Hz / 1,5 kW 60 Hz
solids discharge	manually
liquid return	pressureless by a lateral outlet on the centrifuge housing
inlet tank	-
clean liquid tank	-
remarks /other	compact dimensions, favorable price

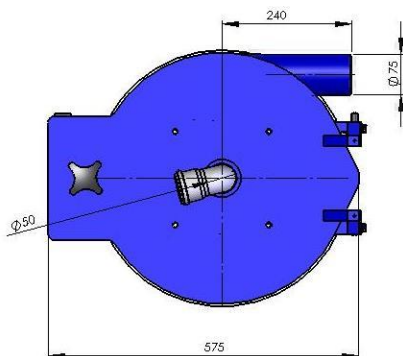

View from above

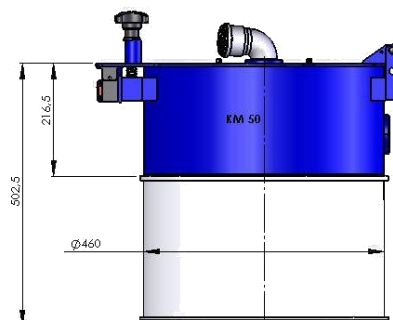

Side view



Turbo-HKS GmbH
 Robert-Gerwig-Strasse 25
 78244 Gottmadingen
 Germany
 +49 (0) 7731 / 8801-0
 +49 (0) 7731 / 8801-18
 www.turbo-hks.com
 info@turbo-hks.com