

C.F.R. srl

Via Raimondo dalla Costa 625 - 41122 Modena (MO) - Italy
Tel: +39 059 250837 - Fax: +39 059 281655 / 2861223 e-mail:
info@cfritaly.com www.cfritaly.com

TECHNICAL MANUAL

DC electric motors 12V to 120V type CA, MP

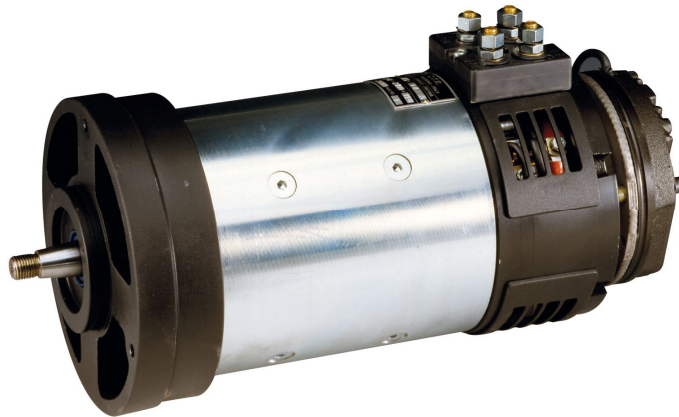



GENERAL INDEX

Heading	Description	Page
1	Introduction	3
1.1	Symbols adopted	3
1.2	General information	3
1.3	General safety warnings	4
1.4	Residual risks	5
1.5	Intended use	5
1.6	Prohibited uses	6
1.7	Identification of operators	6
1.8	Warranty conditions	6
1.9	Declaration of conformity	7
2	DC motors	8
2.1	Design	8
2.2	Motor identification and data plate	12
2.3	Nominal operating characteristics	13
2.4	Types of duty	13
3	Handling and transport	15
3.1	Preliminary warnings	15
3.2	Handling of motors	16
4	Installation and commissioning	17
4.1	Acceptance and storage	17
4.2	Installation and commissioning	17
4.2.1	Preliminary warnings	17
4.2.2	Keying	20
4.2.3	Electrical connections	21
4.2.4	Connections for different types of winding	23
4.2.5	Accessories	25
4.2.6	Connection of an external encoder	27
4.3	Reminders on incorporation procedures	28
5	Maintenance	29
5.1	General maintenance	30
5.2	Major servicing	33
5.3	Decommissioning	35
6	Troubleshooting	36



1 INTRODUCTION

1.1 SYMBOLS ADOPTED



IMPORTANT:

Read the highlighted information with care, and follow instructions to the letter.



CAUTION

This symbol warns the reader to pay maximum attention to the highlighted information. Failure to follow instructions can result in serious damage to persons or to the product.



FORBIDDEN

Pay careful attention to the highlighted instructions.

1.2 GENERAL INFORMATION





It is important that all the precautions indicated in the manual are strictly observed. In the event that the expected conditions of use or technical data are not covered by this document, contact C.F.R. so that the application can be evaluated.

The purpose of this document is to provide the user with all the information needed to ensure correct selection and proper use of the products described.

	Products must be used according to the methods described in this document, by persons who are properly trained for the purpose.
	Customers are responsible for ensuring correct selection and use of the product on the basis of their industrial and/or business needs. With the state of the art constantly evolving, C.F.R. reserves the right to update and improve the content of this literature at any time, making changes which however cannot be regarded as binding. Responsibility for the selection of the product lies ultimately with the Customer, unless otherwise agreed in writing between the parties.







1.3 GENERAL SAFETY WARNINGS

	<p>DC electric motors contain dangerous parts and carry various types of risk; consequently, it is essential to observe all the safety warnings indicated.</p> <p>The electric motor must be used only after proper training has been given and the following instructions have been read.</p> <p>Technicians entrusted with installation, commissioning, inspection, maintenance and repair operations must be suitably qualified and familiar with general safety regulations both in the country of origin and in the country where the product will be installed. They must also have received specific technical training that will enable them to identify and avoid every potential danger. In particular, maximum caution must be exercised in respect of live components, rotating parts and hot surfaces.</p> <p>The electric motor must not be operated in hostile environmental conditions. Be certain to abide by the parameters indicated in this manual.</p> <p>Important:</p> <ul style="list-style-type: none">• do not deactivate or tamper with protection devices; if safety systems are tampered with or by-passed, C.F.R. will acknowledge no liability for any damage that could occur as a result;• if an electric motor develops a fault and/or is not running smoothly, withdraw it from use and label it officially out of service. If repairs are required, contact C.F.R. Technical Assistance.
	<p>An electric motor must not be installed in areas where potentially explosive atmospheres can be created or where there is a high fire risk.</p> <p>Commissioning of the motor must not proceed if the driven machine is found to be at variance with the pertinent directive.</p>
	<p>Always use appropriate items of personal protective equipment, e.g. gloves, safety eyewear, etc...</p>
	<p>Do not run the motor if it has become damaged during transport or assembly; in this instance contact C.F.R. for instructions on how to proceed.</p> <p>Use only original replacement parts or accessories, or in any event those authorized by C.F.R srl. If this condition is ignored, claims for repairs or damages will not be recognized.</p> <p>Avoid swallowing oil, grease or other material from the electric motor, and do not dispose of these items irresponsibly.</p> <p>Do not clean or wash the motor with solvents or pressurized water jets. These are actions that could damage the product. Do not clean the electric motor using flammable substances, and never use cleaning compounds that are corrosive or harmful to health.</p> <p>Do not apply paint to the electric motor.</p>



1.4 RESIDUAL RISKS

 	<p style="text-align: center;">Danger from moving parts</p> <p>Take particular care to avoid any kind of physical contact with moving parts. Install control components that will allow the motor to be started and stopped both under normal operating conditions and in an emergency.</p> <p>Be careful to stop the motor and wait a few minutes before commencing maintenance operations, making certain that all moving parts have slowed to a complete standstill.</p>
	<p style="text-align: center;">Danger from explosion and fire</p> <p>Do not install the motor outdoors or in hostile environments without first checking the level of protection specified.</p> <p>A DC motor can continue to carry voltage even after the stop control has been operated: after testing the earth system, for example, certain parts may present residual risks of explosion. Make certain live parts are completely safe before working on the motor.</p>
	<p style="text-align: center;">Waterless fire extinguishers only</p> <p>In the event of fire, put out flames only with extinguishers using powder or CO₂.</p>
	<p style="text-align: center;">Danger of burns through contact with motor surfaces</p> <p>Remember always to wait a few minutes after shutting down the machine before working on the motor, as some hot parts may not cool down immediately.</p> <p>Before starting up the motor, ensure that parts made of plastic or temperature-sensitive materials are shielded from sources of excessive heat.</p>

1.5 INTENDED USE

C.F.R. electric motors are intended for incorporation into machines, generally for professional use, secured to fixed mountings such as the machine frame or baseplate and designed to cover the widest imaginable range of applications.

Electric motors are not normally designed for use in conditions exposed directly to the elements. If electric motors are to operate in hostile environments with notable levels of dirt, water splash, heat or humidity, they must be equipped with special guards. For applications requiring electric motors equipped with special protective enclosures, contact the C.F.R. sales office to ensure these are ordered correctly.

1.6 PROHIBITED USES

The intended use for C.F.R. electric motors is as described above. Any other uses not specifically indicated are prohibited.

The following are severely prohibited:

- Tampering with parts of the motor or fitting replacements not supplied by C.F.R.
- Use in environments where potentially explosive atmospheres can be expected.
- Connection to power sources and use in conditions other than those described in the technical specifications

	<p>The electric motor must absolutely not be used in an improper manner and/or operated before it has been definitively installed in and interfaced with the driven machine.</p> <p>Where electric motors are used for unsuitable or unspecified applications, warranty is automatically invalidated and C.F.R. will decline liability for any damage that may be caused to persons or property.</p>
---	--

1.7 IDENTIFICATION OF OPERATORS

Given that certain activities essential to the use of electric motors involve the exposure of operators to specific risks (e.g. connections at installation), persons entrusted with the operations described in this document, from installation through to maintenance, must be properly trained in accordance with current statutory regulations.

1.8 WARRANTY CONDITIONS

The motors referred to in these instructions are guaranteed for 12 months from the date of consignment by C.F.R. Any warranty arrangements of a different nature or duration must be negotiated with C.F.R. and included in the agreed contractual conditions.

The warranty cover is limited strictly to cases of malfunction deriving from defects of manufacture, in accordance with the indications given in this document. C.F.R. acknowledges no liability for damage caused to machinery or systems in which the motor is installed. Warranty covers the repair or replacement only of defective motor parts. Warranty does not cover any defect attributable to installation, maintenance, cleaning or parts replacement procedures that have been performed incorrectly or ineffectively.

If a claim under warranty is acknowledged by C.F.R., the defective component will be replaced or repaired by the company's own staff. Warranty does not cover parts subject to normal wear and tear. Warranty claims will not be acknowledged in cases of incorrect installation or maintenance, tampering with the product, improper use, or damage sustained during transport, handling and storage. All transport costs incurred in returning the product to C.F.R. and restoring it subsequently to the customer are excluded from the warranty.

1.9 DECLARATION OF CONFORMITY AND INCORPORATION

The manufacturer:

C.F.R. srl, with registered office at Via Raimondo dalla Costa, 625, 41122 – Modena (MO) – Italy, in the person of its Legal Representative Mr Luciano Cottafavi

Declares under its own responsibility that products manufactured by the company under the name:

DC electric motors - type CA, MP.

to which this declaration relates, are in conformity where applicable with the following directives:

- 2006/95 (low voltage),
- 2004/108 (electromagnetic compatibility),
- 2006/42/CE (machinery), insofar as they meet applicable safety requirements and are capable of being incorporated into a machine

The electric motors are also in conformity with the following technical standards:

EN 60034-1
EN 60034-5
EN 60034-7

Furthermore:

- The technical file is held by C.F.R. srl with registered office at Via Raimondo dalla Costa 625, 41122 – Modena (MO) – Italy, in the person of its legal representative,
- C.F.R. undertakes to transmit information regarding its products, in response to any reasonable request from the national authorities. This undertaking is given in respect of the method of transmission and without prejudice to the intellectual property rights retained by the manufacturer of the product,
- **Electric motors must not be commissioned until the system or the machine into which they will be incorporated have been declared as being in conformity with the requirements of applicable directives.**

Modena, 05/05/2014

Signed

.....
Luciano Cottafavi
(Legal Representative of C.F.R. srl)



2 DC MOTORS

2.1 DESIGN

These are electric motors operating off a low voltage d.c. power supply, designed for general use in industrial applications.

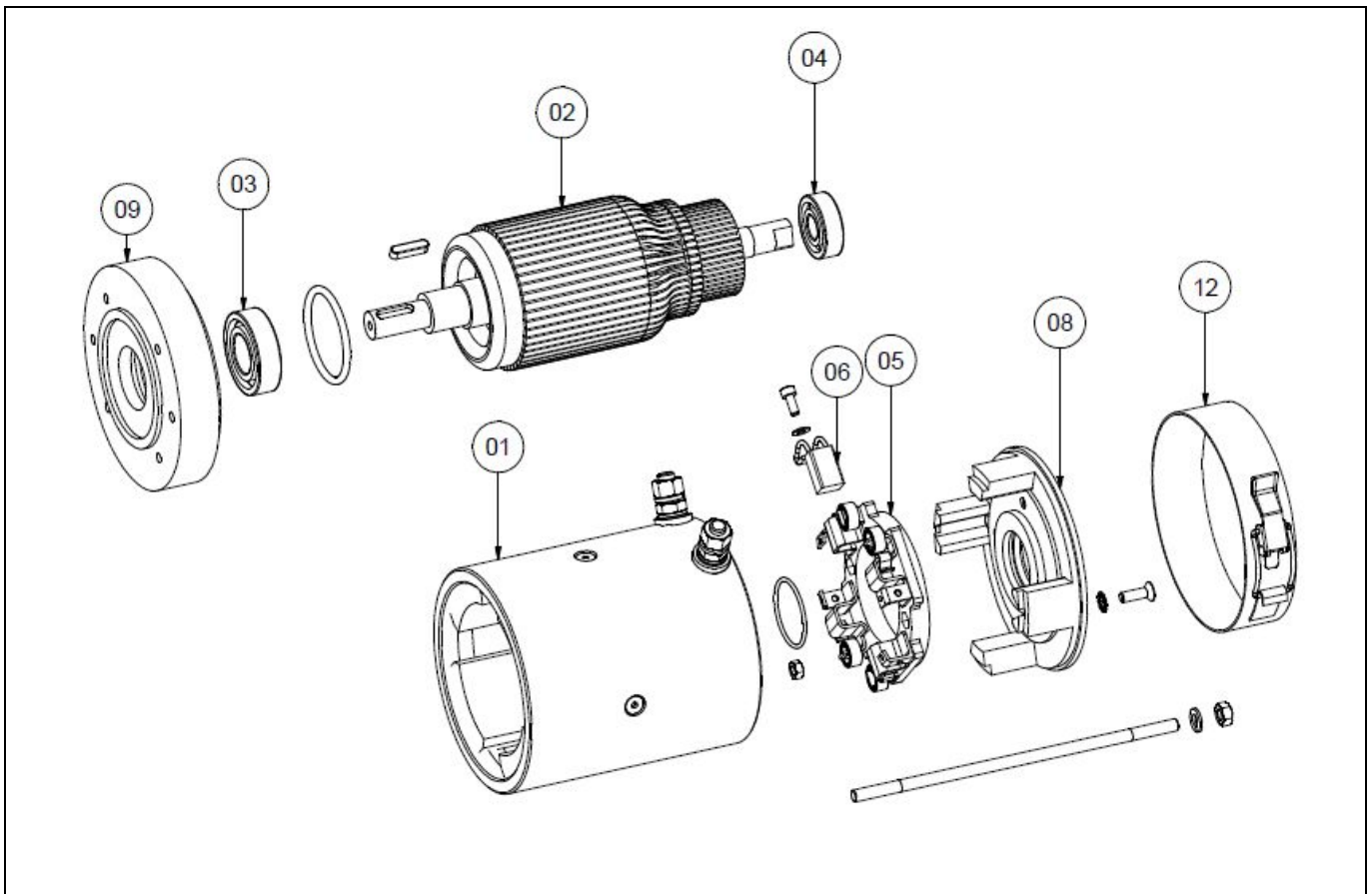

MOTOR TYPE MP

Ref	Description	Ref	Description
01	CASE	06	BRUSH
02	ROTOR	08	BRUSH-HOLDER CASTING
03	BEARING	09	FRONT END COVER
04	BEARING	12	CLIP
05	BRUSH-HOLDER		

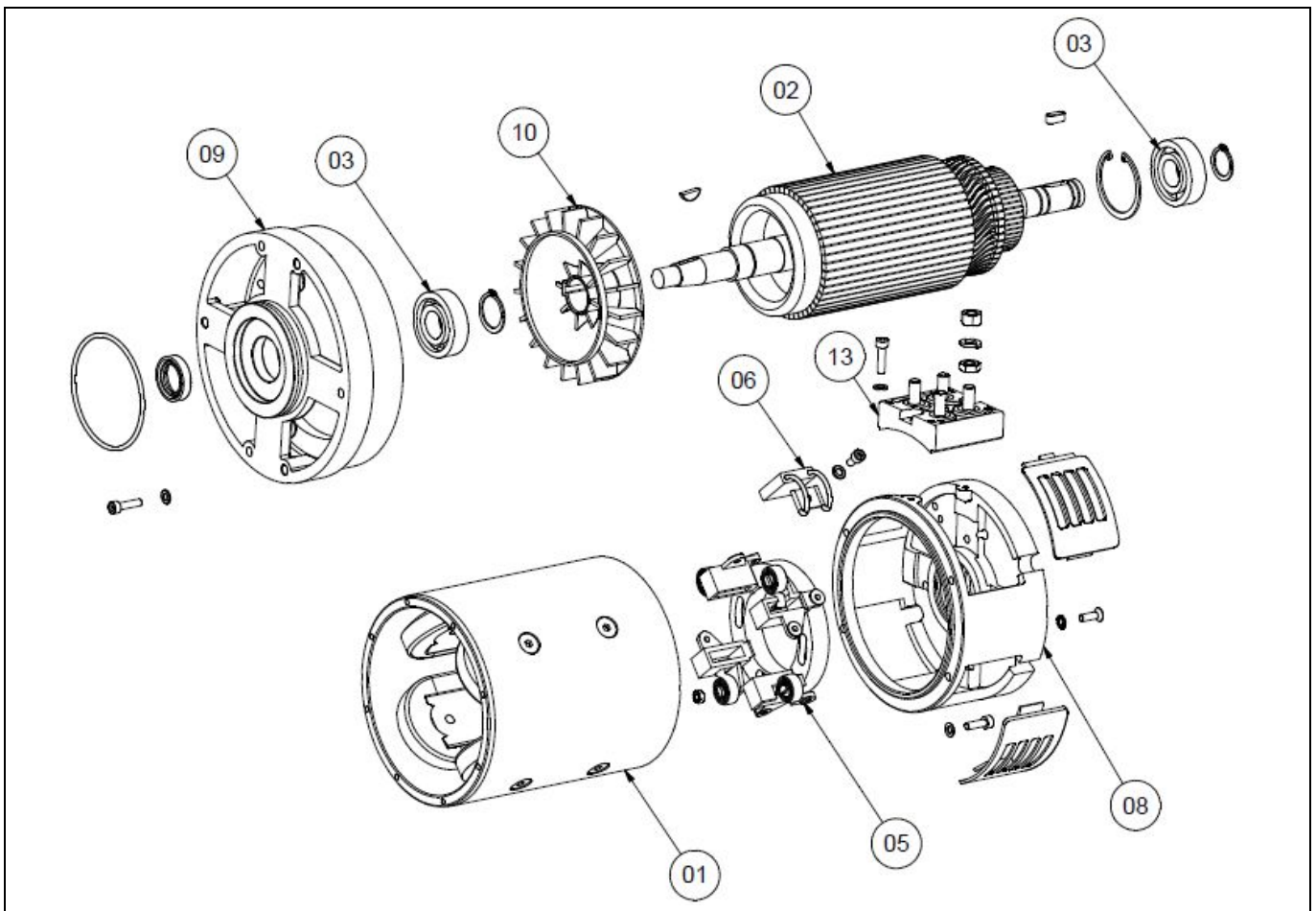

MOTOR TYPE CA			
Ref	Description	Ref	Description
01	CASE	08	BRUSH-HOLDER CASTING
02	ROTOR	09	FRONT END COVER
03	BEARING	10	FAN
05	BRUSH-HOLDER	13	TERMINAL BLOCK
06	BRUSH		

Main parts of the motor:

- **Case:** steel, protected externally by zinc coating or paint finish.
- **Flanges and end covers:** can be made of aluminium, cast iron or steel.
- **Motor shaft:** always steel, with both male and female output configurations at the coupling end and at the end opposite. Special shafts can be supplied if requested by the customer.



- **Bearings:** these are double-shielded, grease lubricated low clearance radial ball bearings designed specifically for electric motors. Efficient lubrication is guaranteed at operating temperatures up to 100 °C maximum.
- **Brushes:** these can be carbon or metal-graphite, depending on the technical specifications of the motor. The brushes are positioned for ease of access and can be replaced quickly and simply if necessary. Motors can be supplied with 2, 4, 8, 12 brushes; selection between the models is required in order to avoid exceeding a given current density at the single brushes.
- **Types of ventilation:** motors can be designated
 - **NV:** non ventilated motor, generally with ingress protection IP 44 or higher.
 - **VA:** front end — the fan is located at the coupled end of the motor shaft. This configuration is generally adopted when the rear end of the motor shaft is fitted with an electromagnetic brake or other accessory.
 - **VP:** rear end — the fan is positioned at the rear end of the motor, behind the brushes.
 - **VF:** forced ventilation — the motor is equipped with an external fan unit and a special ducting arrangement. This type of ventilation is recommended when the motor may be operated at low running speeds or used for particularly heavy work cycles (continuous duty S1).



NV



VA



	
VP	VF

- **Insulation:** both the armature and field windings are assembled with round or flat copper wire, insulated to class H, and the rotor is also impregnated with epoxy resins and varnished to withstand temperatures up to 155 °C.
- **Motor enclosure rating:** ingress protection from IP 00 to IP 66, on request.

	<ul style="list-style-type: none">• Terminal box enclosure rating: motors can be supplied with terminal box or exit cables having ingress protection from IP 00 to IP 66.
---	--

- **Type of winding:** in the case of wound field designs, C.F.R. can supply:
 - **Series excited motors**
 - **Compound excited motors**
 - **Shunt excited motors**
 - **Separately excited motors**

DC motors will generally operate with electronic controls. Before commissioning the motor, check for compatibility between the type of winding and the control that will be utilized.

	
---	--

In addition, if requested, C.F.R. can supply:

- **Electromagnetic brakes:** The electromagnetic brakes supplied are generally negative acting: when the circuit is powered up, the brake releases; when powered off, the brake is applied
- **Bimetal thermal sensors:** normally closed or normally open, with temperature thresholds of 90 °C, 110 °C, 140 °C. Used to protect the motor from excessively high temperatures. Items supplied on request when ordering
- **Mounting feet:** fixing feet can be supplied for certain types of motor
- **Painting:** motors can be supplied with special paint finishes, if requested
- **Brush wear indicators:** brushes are available with wear indicators, if requested
- **Starting contactors**
- **Encoders or dynamos**

2.2 MOTOR IDENTIFICATION AND DATA PLATE

All motors made by the company are identified by a data plate, as illustrated below:



The data plate contains the following information:

Power	P = 900 W	Duty	Duty cycle
Voltage	U batt = 44 V	Ins.Cl	F Insulation class
Current	I = 26 A	IP	20 Ingress protection
Speed	n = 2600 rpm	F.F.	1 Form factor
Torque	t = 3.3 Nm	Tested	06/13 Testing date
Bar code			
Type	MP113.0223	Motor designation code	
Serial number	MP113-NV-Q DS	Notes	
	Serial 00000002		



Many items of technical data on the plate are self-explanatory. For further information, refer to drawings supplied with the accompanying documentation, or contact C.F.R. direct



2.3 NOMINAL OPERATING CHARACTERISTICS

Unless otherwise indicated, the operating characteristics refer to:

- duty cycle S2 60 min;
- ambient temperature: 0 °C – +40°C;
- maximum altitude 1000 m above sea level;
- power input at nominal voltage and frequency; maximum permissible voltage fluctuation $\pm 5\%$. For maximum and minimum power input values, assume a further $\pm 5\%$ (e.g. a motor rated 48 V is suitable for nominal mains voltages from 45 V to 50 V).



The efficiency of a motor may be reduced if input voltages deviate from the nominal rated values.

2.4 TYPES OF DUTY

Duty cycles are explained in the following summary of the reference standards and the definitions adopted.

- **Load:** the combined values of electrical and mechanical quantities that characterize the requirements placed on a rotating machine by an electrical circuit or by a mechanical device, at a given moment.
- **Duty:** the definition of the load, or loads, to which the machine is subject, which include (if applicable) starting, electric braking, no-load and idle periods, as well as their duration and their sequence over time.

EN 60034-1 standards define different types of duty. Those of interest for C.F.R. products are:

Continuous Duty – S1

Operation at constant load for a duration sufficient to reach thermal equilibrium.

P = Load

P_v = Electric losses

T = Temperature

t = Time

T_{cc} = Time period of operation at constant load

T_{max} = Maximum temperature recorded

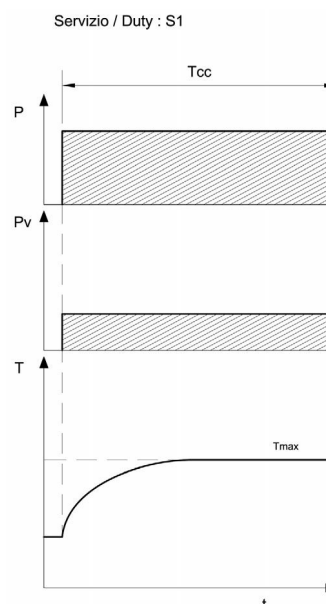



Short time duty – S2

Operation at constant load for a given period of time less than that required to reach thermal equilibrium, followed by an idle period of duration sufficient to re-establish equality between the temperature of the machine and the temperature of the cooling fluid, with a tolerance of 2°K.

Example: S2-60 min

The motor operates continuously under nominal rated conditions for 60 min, then remains idle for a duration sufficient to return to ambient temperature.

P = Load

Pv = Electric losses

T = Temperature

t = Time

Tcc = Time period of operation at constant load

Tmax = Maximum temperature recorded

Servizio / Duty : S2

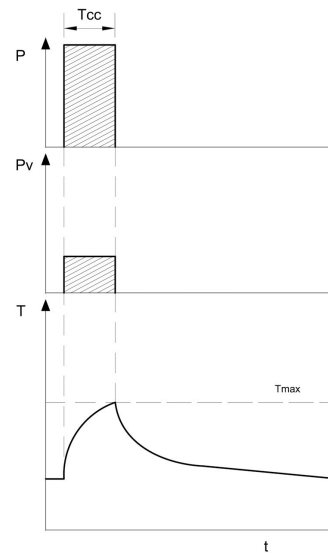

Intermittent periodic duty – S3

Sequence of identical operating cycles, each comprising a period of operation at constant load and an idle period.

Duration of cycle 10 minutes.

In this duty cycle, the sequence is such that the starting current has no significant effect on temperature rise. The nature of periodic duty dictates that thermal equilibrium is never reached during the on-load period.

Example: S3-70%

The motor runs for 7 minutes and remains idle for 3 minutes

P = Load

Pv = Electric losses

T = Temperature

t = Time

Dc = Duration of single cycle

Tcc = Time period of operation at constant load

Tr = Idle period

Tmax = Maximum temperature recorded

Intermittent ratio = $T_{cc} / (T_{cc} + T_r)$

* 100%

Servizio / Duty : S3

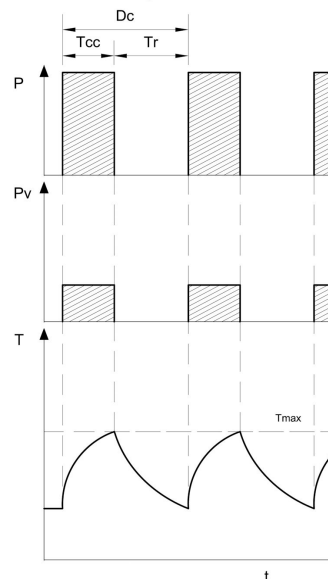





3 HANDLING AND TRANSPORT

3.1 PRELIMINARY WARNINGS

All C.F.R. products are prepared for shipment packed in wooden crates or steel containers, or boxed on pallets, as appropriate for the weight and dimensions of the particular item. Special packing can be provided on request; in this instance, contact the sales department when placing the order.

	<p>In the case of models that cannot be handled manually, the choice of suitable lifting gear (straps, slings, chains, eyebolts) will depend primarily on the weight of the electric motor.</p> <p>Handling, transport and installation procedures must be carried out by persons properly trained and instructed for the purpose, in accordance with current regulations on health and safety in the workplace.</p>
	<p>If any pack received from a carrier has been seriously damaged, the best policy is to indicate PROVISIONAL ACCEPTANCE, check immediately that the actual product has not been damaged, photographing it if necessary, then provide a written account of the situation and the condition of the product. The product must not be used until written authorization is received from C.F.R.</p> <p>If any parts or components are found to be defective or damaged, contact the Engineering - Sales Department.</p> <p>Should the data plate be damaged, a duplicate must be requested in writing from the Engineering department.</p> <p>Make certain that there are no parts of the packing such as fragments of cardboard, staples etc., occluding or obstructing motor ventilation holes.</p> <p>If electric motors are not going to be used immediately, they must be stored in clean, dry, temperate surroundings, protected from vibration, sheltered from the weather, and preferably covered in such a way that the case cannot be penetrated by dust and debris.</p> <p>Before using a motor, check that all parts are in serviceable condition, especially the shaft, bearings and flanges, and all electrical contacts.</p> <p>Test the insulation of the winding, or windings, using the appropriate instrument.</p> <p>Do not touch the terminals either during tests or immediately afterwards, as they can remain live for a certain duration.</p>
	<p>The materials in which electric motors and relative components are packed must be suitably disposed of at authorized collection sites.</p>



3.2 HANDLING OF MOTORS

Small motors can be handled manually, without lifting gear. Motors that cannot be man-handled are provided with a threaded hole into which an eyebolt of suitable capacity can be screwed.



If necessary, the motor can be cradled using straps or slings of suitable capacity looped around the case at the appropriate points; in any event, be sure to observe current accident prevention regulations.



Do not add further loads to the motor when lifting.

Do not lift a motor by its output shaft or fan cowl, or by plastic parts, terminals or power cables.



4 INSTALLATION AND COMMISSIONING

4.1 ACCEPTANCE AND STORAGE

	<p>Check that the motor is exactly as ordered, and has not been damaged during transport.</p> <p>Eyebolts that may already be fitted to the case must be used only for lifting the motor itself.</p> <p>If the required operating parameters are different to those indicated in the technical specifications, contact the C.F.R. engineering department before proceeding.</p>
---	---

4.2 INSTALLATION AND COMMISSIONING

4.2.1 PRELIMINARY WARNINGS

	<p>When installing the motor, the machine must be at a standstill, and disconnected from the electrical power supply.</p>
---	---

Motors can be installed in any of the mounting positions covered by EN/IEC 60034-7.

The mounting position of the motor must be selected in such a way that:

- The motor can be properly secured, with all threaded fasteners properly tightened.
- In the case of a ventilated motor, there is sufficient clearance between the fan and the frame of the machine to allow a free flow of air.
- All power cables of the motor, electromagnetic brakes and any other components (accessories) supplied with the motor can be fastened securely between nuts and lock nuts or with connectors. In addition, power cables must not be pressed or pinched against other parts (machine frame, flanges, etc...) and must be long enough to ensure they can be connected without difficulty, in other words free of any tensile stress that could place strain on terminals and connections.

When tightening cables to the relative terminals, always use two wrenches as illustrated. Hold the bottom nut stationary to prevent the terminal from turning, then, with the cable termination lug in position on the post, tighten the top nut to obtain a secure and durable contact.



	<p>Do not install near heat sources.</p> <p>Bearing in mind the required ingress protection, install the motor in such a way that foreign matter cannot penetrate the frame, or obstruct the ventilation holes if any.</p> <p>Make certain that water or other liquids cannot infiltrate the motor.</p> <p>Make sure the motor cannot be damaged when the machine is moved for whatever reason.</p> <p>Check that the data plate remains clearly visible once the motor is installed.</p> <p>If the case includes drain holes, check that these are correctly positioned in such a way that condensate can run off freely.</p>
	<p>During the installation procedure, ensure that fixing screws or bolts do not penetrate internally of the motor, as these could damage the electrical windings.</p>

Once in position on the driven machine, all motors must be connected mechanically to the machine pivot so that rotation can be transmitted.



The connections most frequently used are:

- Direct coupling to another component (gear unit, differential, pump...).
- Indirect coupling, by way of pulleys, drive couplings or pinions.

Before coupling the motor, clean and lubricate contact surfaces to prevent any risk of seizing.

If the motor is bolted to a bed or baseplate, ensure that the mounting surface is sufficiently thick, with a flatness tolerance of less than 0.03 mm.

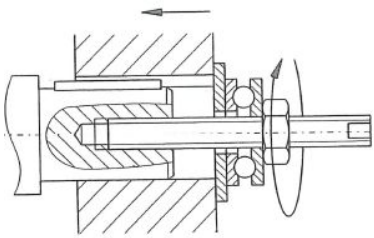

	<p>It is always important to check that the fit tolerances of coupled components are correct and compatible with those of the motor components. In particular, for both direct and indirect coupling arrangements, the rectangularity tolerance between the motor shaft and output flange and the components to be coupled must be less than 0.03 mm.</p> <p>When making the connection, avoid axial or radial loads that could damage the bearings and other components of the motor.</p>	
	<p>Use the appropriate special tools for assembly purposes.</p>	
	<p>To find out the permissible axial or radial loads, always ask for and refer to literature originated by C.F.R.</p>	

Avoid mounting components in such a way as to create overhung loads, and ensure that chains or belts are not tensioned to the point of affecting bearing life, or even causing failure of the motor shaft (see illustration alongside)

a: hub
F: Force

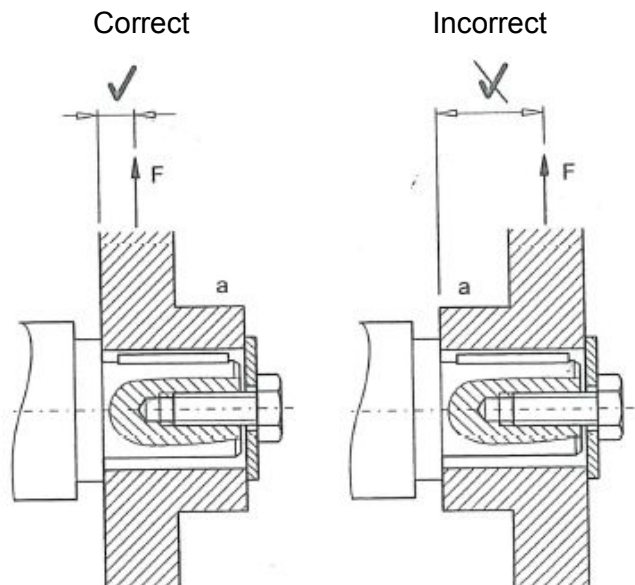



	<p>Make certain there is no way that elements coupled to the motor can cause damage to parts of the machine or injury to persons.</p>
	<p>Ensure that parts of the motor likely to reach high temperatures are suitably protected against possible bodily contact.</p>
	<p>The coupling component and the type of transmission are selected and designed to suit the particular operating conditions. Selection and design are the responsibility of the customer: the responsibility of C.F.R. srl is limited to the reliability of such technical data as the company can be expected to provide to the customer, on request.</p>

The recommended tightening torques for threaded fasteners are:

Bolt size	Tightening torque for typical rated strengths		
	8.8	10.9	12.9
	[Nm]	[Nm]	[Nm]
M4	3	4	5
M5	6	9	10
M6	10	15	18
M8	25	35	41
M10	50	70	85
M12	90	120	145
M16	210	295	355
M20	450	580	690
M24	750	1,000	1,200

A tolerance of +/- 8% is permissible on the above values

4.2.2 KEYING

C.F.R. motors are always balanced with a half-key fitted to the shaft (unless specified otherwise when ordering). Accordingly, transmission components must also be balanced using a half-key. For special keying requirements, refer to the detailed instructions provided by the supplier of the component and by C.F.R.

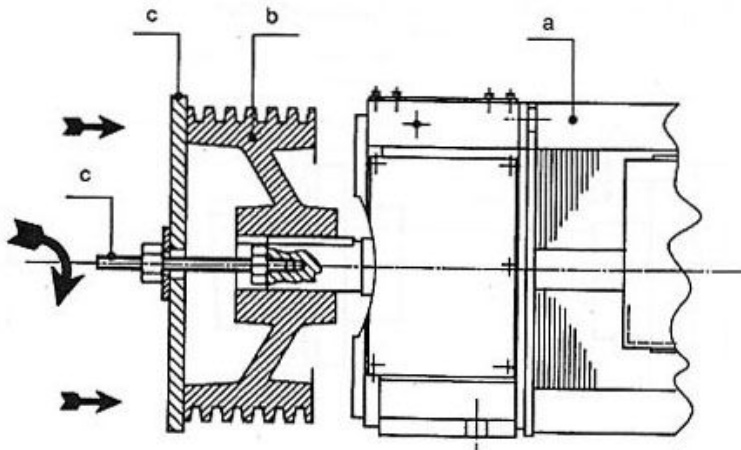

Example of transmission component keyed cold to the motor, using the threaded hole in the end of the shaft.

- a) Motor
- b) Transmission component
- c) Assembly tool



If the end face of the shaft end and/or the hole in the hub are damaged, the defect must be rectified BEFORE proceeding with assembly.

4.2.3 ELECTRICAL CONNECTIONS

C.F.R. srl can supply different types of motors, consequently it is important that each one should be wired according to the instructions provided. If the motor is operated by an electronic control or other device, compatibility between the motor winding and the control must be verified.

	<p>Before making the electrical connection, make certain that the power supply matches the values indicated on the data plate.</p> <p>Make the electrical connections to the motor and to auxiliary items when the machine is idle, with the motor isolated from the mains power supply.</p>
	<p>Use cables of section large enough to prevent overheating and/or excessive voltage drop at the motor terminals. Remove the key from the keyway before starting the motor with the shaft uncoupled, otherwise it could be flung out with considerable force.</p>
	<p>Be careful, when connecting the motor and the electronic control, to proceed strictly in accordance with the wiring diagram illustrated below.</p>



Motors can turn in either direction of rotation, left or right: if the direction is not as required, consult C:F:R. for information on how to select the correct direction.
In addition, always consult the connection-related information provided by the maker of the electronic control device.

Example of connection between d.c. motor with accessories, and electronic control.

Electronic control for DC motors

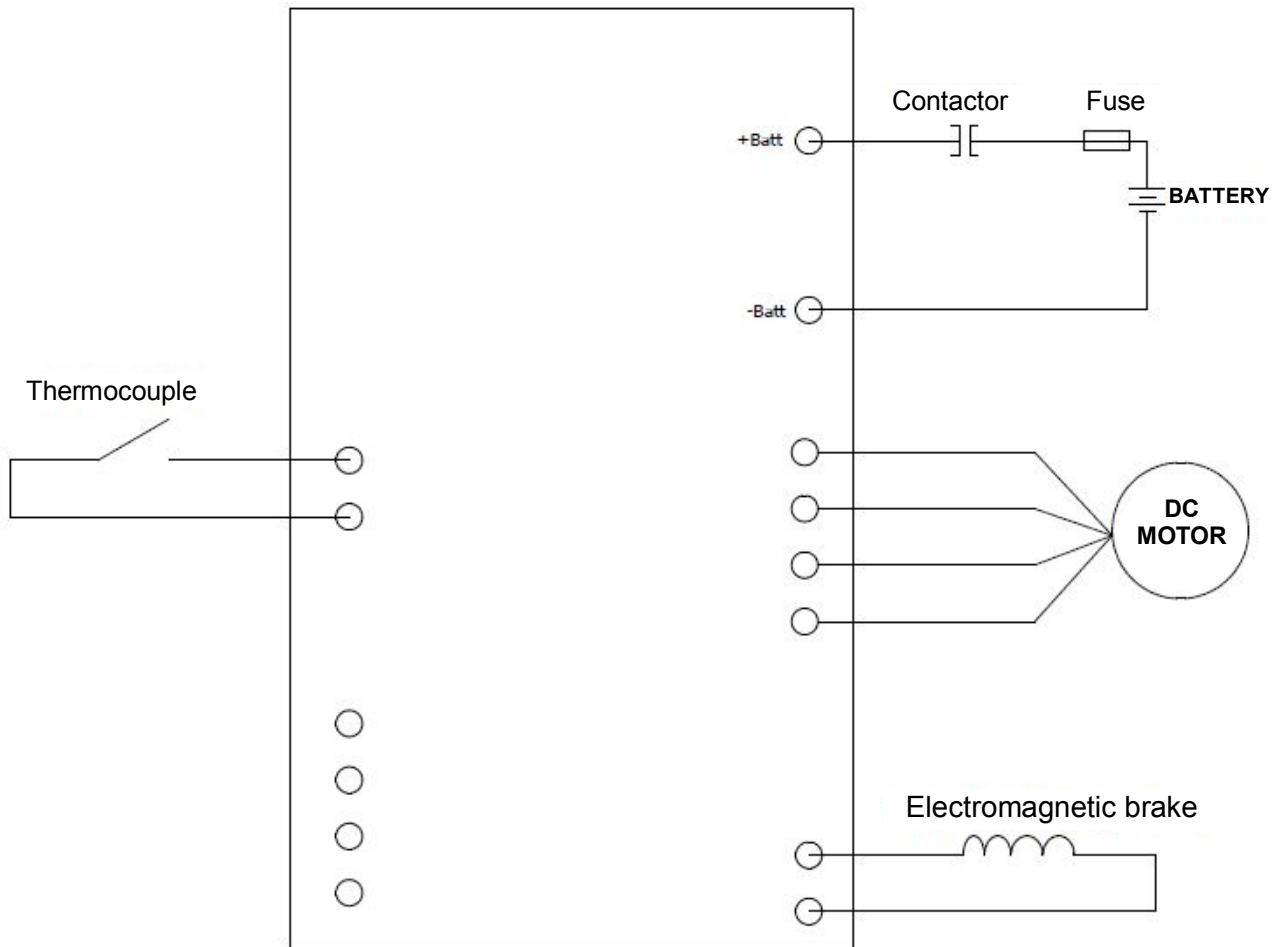



4.2.4 CONNECTIONS FOR DIFFERENT TYPES OF WINDING

SERIES excited motors	
<p>RA</p> <p>2 Terminals</p>	<p>Series-wound motor with 2 terminals: this motor can have one direction of rotation only. Important: the required direction of rotation must be specified when ordering.</p>
<p>RC</p> <p>3 Terminals</p>	<p>Series-wound motor with 3 terminals: this motor can have two directions of rotation.</p>
<p>RE</p> <p>4 Terminals</p>	<p>Series-wound motor with 4 terminals: this motor can have two directions of rotation.</p>
<p>RF</p> <p>5 Terminals</p>	<p>Series-wound motor with 5 terminals: this motor can have two directions of rotation and two speeds.</p>
COMPOUND excited motors	
<p>NA</p> <p>2 Terminals</p>	<p>Compound-wound motor with 2 terminals: this motor can have one direction of rotation only. Important: the required direction of rotation must be specified when ordering.</p>



SHUNT excited motors	
<p>PA</p> <p>2 Terminals i</p>	<p>Shunt-wound motor with 2 terminals: this motor can have one direction of rotation only. Important: the required direction of rotation must be specified when ordering.</p>
<p>PB</p> <p>4 Terminals</p>	<p>Shunt-wound motor with 4 terminals: this motor can have two directions of rotation.</p>
SEPARATELY excited motors	
<p>SB</p> <p>4 Terminals</p>	<p>Separately-wound motor with 4 terminals: this motor can have two directions of rotation.</p>
PERMANENT MAGNET motors	
<p>MP</p> <p>2 Terminals</p>	<p>Permanent magnet motor with 2 terminals: this motor can have two directions of rotation and two speeds.</p>

The code for the type of winding is indicated on the motor data plate.

4.2.5 ACCESSORIES

Various accessories requiring an electrical connection can be installed on the motor, if requested.

Thermal overload protections

Motors used for heavy duty applications can be protected against excessive overheating by means of a bimetal thermal sensor. This protection device must be specified when ordering the motor. C.F.R. supplies 3 different thermal overload sensors with temperature thresholds of: 90 °C, 110 °C and 140 °C (+/- 8 °C); different thresholds are available on request.

The thermal sensor is generally embedded in the winding, with two relative wires emerging from the motor; these must be connected as indicated in the wiring diagram.

THERMOCOUPLE TYPE S 01 WITH AUTOMATIC RESET AND CONNECTING CABLE	
Switching method	breaker contact
Switching temperature threshold	90 °C, 110 °C, 140 °C
Tolerance	+/- 5 °K
Measurement current / n° cycles	2.5 A / 10 000, 5 A / 3000
Standard connection	Cable of 0.25 mm ² section





Connection of electromagnetic brake

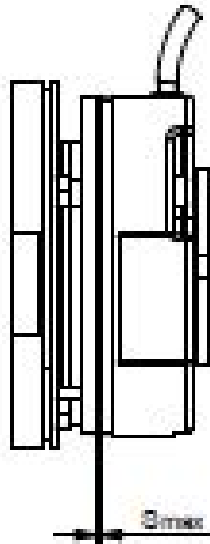

If the motor is equipped with an electromagnetic brake, this must also be connected to the electrical circuit.

The electromagnetic brakes we supply are generally negative acting: when the circuit is powered up, the brake releases; when powered off, the brake is applied.

All brakes are supplied calibrated and mounted with 3 screws, normally at the rear end of the motor.

The middle screw can provide a torque rise of $\pm 10\%$.

Torque, power requirement and maximum air gap values are indicated in the following table:

Size	Nominal braking torque	Power at 20 °C	Smax
	[Nm]	[W]	[mm]
06	4	20	0.3
08	8	25	0.3
10	16	30	0.3
12	32	40	0.5
14	60	50	0.5
16	80	60	0.5



Smax indicates the maximum permissible air gap, beyond which the brake must be recalibrated and, if necessary, the brake disc replaced.

4.2.6 CONNECTION OF AN EXTERNAL ENCODER



Connection of an external encoder

An external encoder can be fitted to the motor, if requested by the customer.



The external encoder is not essential for control of the actual motor, but will be used to increase the resolution of speed and position signals utilized in monitoring the performance of the driven machine.



If requested by the customer, C.F.R. will prepare the motor shaft to accept the installation of any encoder selected and installed subsequently by the customer.

	<p>An external encoder must not be connected to the electronic control governing the motor, but to the electronic control governing the driven machine as a whole.</p>
	<p>All wiring operations must be entrusted to an expert installation/service technician and undertaken with maximum care.</p> <p>C.F.R. recommends users to procure the proper connectorization tools for the various cables.</p>





4.3 REMINDERS ON INCORPORATION PROCEDURES

During the process of installing the motor in the driven machine, all of the various controls must be included: start, stop, emergency stop devices if applicable, and machine safety devices. The motor must be protected permanently against unacceptable power input or loading situations, and against malfunction or breakdown. C.F.R. srl can assist in identifying the most suitable protection systems for particular cases. Where the requisite protection systems are omitted or incorrectly calibrated or found to be ineffective, C.F.R. srl will decline all liability in respect of faults or failures.

	<p><u>Electrical protections</u></p> <p>Motors are not supplied with any kind of electrical protection installed (e.g. fuses, thermal-magnetic breakers...); it is the responsibility of the user to ensure that protections against short-circuit and overvoltage are provided.</p>
	<p><u>Mechanical protections</u></p> <p>Before machines are commissioned, the user must make certain that all moving parts are suitably protected; in particular, the machine must not be commissioned if:</p> <ul style="list-style-type: none">• The motor has not been suitably fixed.• The cover of the terminal box, if specified, has not been properly fitted and secured with its screws, to prevent accidental contact with live parts.• Power cables have not been suitably connected and protected against accidental contact with live parts.• The cowl of the cooling fan, if specified, has not been correctly fitted.• Motors presenting accessible moving parts have not been properly protected. <p>In addition to mechanical protections associated specifically with motors, the user must also make certain that all components connected to the driven machine and set in motion (couplings, pulleys, driver belts, etc.) are suitably protected against accidental contact.</p>
	<p><u>Protections against thermal risk</u></p> <p>The outer surfaces of motors can reach particularly high temperatures.</p> <p>The user must deploy suitable guards that will prevent operators from coming into contact with hot parts, whether intentionally or unintentionally.</p>



5 MAINTENANCE

	<p>All maintenance operations must be carried out by skilled service technicians.</p> <p>If in doubt, or in need of any information on the use of electric motors, always contact C.F.R. technical assistance.</p>
	<p>Any maintenance operation on the motor must be carried out with the machine at standstill and disconnected from the power supply (including auxiliary circuits). Irregularities or abnormalities discovered during an inspection must be remedied without delay.</p> <p>Do not carry out maintenance work when the electric motor is running or connected to the power supply. Make certain that the motor has been disconnected from the power supply and always wait a few minutes after it has been shut down, as there are parts that may still be hot.</p> <p>When work is completed, replace guards and protections that have been removed.</p> <p>Take every precaution during maintenance operations to ensure that the motor cannot be started up by unauthorized persons.</p>
	<p>If the electric motor needs to be painted, contact C.F.R. srl for instructions.</p> <p>To ensure maintenance is performed correctly, it is always advisable that the electric motor should be removed from the machine in which it is installed.</p>
	<p>During maintenance work, wear suitable items of personal protective equipment; wait for a few minutes until the electric motor has cooled down sufficiently and come to a complete standstill.</p>
	<p>Do not release or dispose of residual matter into the surrounding environment when carrying out maintenance. Always observe statutory regulations on waste disposal.</p>

The frequency of inspections will depend mainly on the number of hours the motor has been running and on ambient conditions; in any event, current regulations on the servicing of machinery must be observed.

5.1 GENERAL MAINTENANCE

As electrical appliances with parts engaged in sliding contact (brushes on commutator), DC motors require periodic maintenance. It is therefore important that the motor should be serviced at regular intervals, to ensure smooth operation and long service life.

Checks to be carried out at installation and at least once a year

- Check that there are no traces of debris, oil or water on the motor, and that these have caused no damage to any parts of the motor, especially wiring components. Clean all components if necessary, and before reassembly, test the insulation of the stator and the rotor.
- Check that the entire cooling circuit (case, fan cowl air inlet vents, motorized fan unit if any) is free of dust, oil and any process waste, in order to ensure that the motor will not overheat due to the normal flow of cooling air being impeded.
- Check that all connections — whether cables secured to terminals or connectorized cables — are clean, neatly arranged and properly tightened. If connections are damaged, they must be renewed or replaced.
- Check that the motor runs free of vibration and without abnormal noise. If vibrations are detected, check that the motor is fastened securely and that the driven machine is properly balanced.
- Where drive belts are in use, check that these are correctly tensioned, as a belt that is too tight can significantly reduce the life of motor bearings and even cause failure of the shaft extension.
- Where O-rings, seals and other protection devices are installed, check their condition and replace if necessary with identical components.
- Check that all additional components fitted to the motor, such as contactors, thermal sensors or external fan units, are operating as they should and calibrated as per specification.
- Check that the insulation between phase and earth is greater than 2 mOhm.
- Check that the springs on the brush-holder ring have not been damaged by excessive heating, and are still applying sufficient force to hold the brushes against the commutator.
- Check that the surface of the commutator is clean and even, presenting no grooves or scorch marks.

Inspection of bearings: at least once a year

All bearings used by C.F.R. are designed specifically for electric motors, with double seals and grease lubrication, and do not require any special maintenance; all the same, it is good policy to check on a regular basis that they are functioning correctly when in operation.

Bearing life can vary to a considerable extent depending on the nature of the loads applied to the motor and the starting cycles adopted, also on temperature and humidity levels in the operating environment. Excessive bearing noise will generally indicate the need for replacement.

If the motor has been commissioned only recently, the first area to check is the coupling (rectify any possible misalignment or check the tension of drive belts, if in use; see also heading 4.2). If bearing noise persists after remedial action has been taken, this means the bearings are already impaired and must be replaced.

Inspection and replacement of brushes

In DC motors, current is fed to the rotor by way of brushes that require periodic maintenance.

The brushes should be inspected at least once a year (or every 500 hours in the case of heavy duty applications). In particular, assess how far the brushes have been lowered from their original height, and check that there is sufficient pressure from the springs. The brushes must be replaced when worn beyond a certain point. To find out the reduction in height at which replacement becomes necessary, contact the C.F.R. engineering department. Whenever the brushes are replaced, the commutator must also be ground smooth and the mica segments undercut.



Generally speaking, the diameter of the commutator can be reduced by turning on a lathe, removing up to 2 mm approx of material (for further details regarding this procedure, contact the C.F.R. engineering department); to ensure the operation is performed correctly, take care not to damage the soldering on the collar of the commutator. Thereafter, the mica segments between the

commutator bars must be undercut to a depth of no more than 0.4 mm; finally, the outer surface of the commutator is ground with a diamond tool to restore the finish. This done, it is advisable to test the insulation of the rotor. The rotor should also be rebalanced following these operations.

When replacing the brushes, follow the steps indicated below, referring to the illustration:

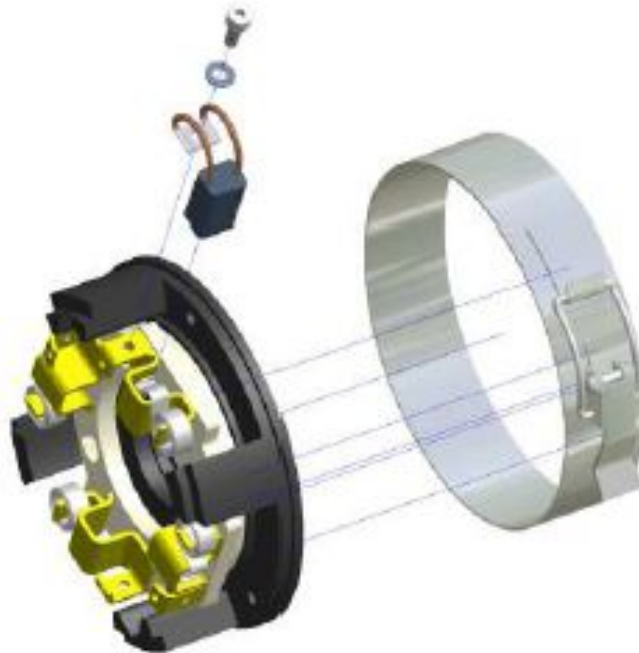

- 1) Disconnect the motor from the power supply.
- 2) Remove the clip and the protective grilles, if fitted.
- 3) Lift the spring retaining the brush in position on the commutator, and remove the brush from its holder.
- 4) Undo the screw and remove the brush from the motor.
- 5) Clean the brush-holder thoroughly, then fit the new brushes and secure with the relative screws in such a way as to ensure an efficient electrical contact; finally, check that the brushes slide smoothly in their seats. Reposition the springs on the brushes.
- 6) Take care throughout this procedure that no foreign matter finds its way into the motor.
It is important that brushes are replaced with identical parts, or in any event, with parts approved by C.F.R.
Never use brushes having a different chemical composition or of dissimilar size; this could result in damage to the motor.
- 7) Reassemble the various components by repeating the above steps in reverse order.

5.2 MAJOR SERVICING

Replacement of bearings

Always remove bearings with the aid of a puller, taking care not to deface or damage the motor shaft.

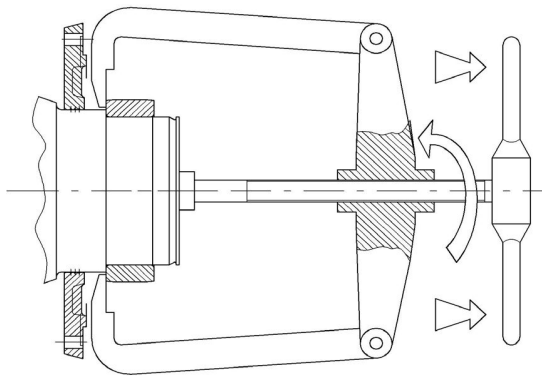

Removal of bearing
turning
the handle
of the puller

Before bearings are fitted, make certain the relative seats have been thoroughly cleaned. Bearings should be fitted using a press, taking care not to damage the ball races. Check that the bearing rings are correctly abutted against the shoulders of the shaft and of the relative flanges, also that the replacement bearings are of the same type as the original components, or equivalent. Where shaft seals are fitted, these should always be renewed throughout.



When removing and replacing motor components installed with protective mastic and/or silicone sealant, make certain that the same level of protection is reinstated following reassembly.

Replacement of motor:



All operations must be entrusted to expert service technicians and carried out in accordance with current regulations, using the requisite items of Personal Protective Equipment.

Before commencing any removal steps, the motor and any accessories installed should be disconnected completely from the power supply.

It is always preferable, where possible, to remove the motor from the machine and position it on a work bench.

Proceed to strip down the motor, following the steps described:

- If the motor has a fan, remove the fan cowl, and the propeller,
- Disconnect the cables from the terminals,



- The motor shaft (rotor) is always retained at one of the two flanges by a circlip preventing axial movement; remove the circlip, proceed to remove the two flanges, and the rotor can then be separated from the case.



Take care not to damage the rotor or the stator winding when separating one from the other.

- Proceed to remove the bearings, which may be force fitted to the motor shaft or to the flanges; in either case, use the appropriate pulling tools or drivers, being careful not to damage the seats.

C.F.R. will undertake the overhaul and repair of motors at its own premises. In any event, the work must be entrusted only to expert service technicians who are able to guarantee that the motor will be returned to its faultless original condition.

When carrying out an overhaul or repair, always use original replacement parts, or at least parts approved in writing by C.F.R.

To obtain correct information on the product, indicate

- Motor designation code
- serial number
- date of manufacture

In the case of maintenance, it is always advisable that bearings and shaft seals should all be replaced.

Following the removal steps, conduct a visual inspection to verify the mechanical integrity and functional efficiency of all components, replacing any that are found to be defective or worn (e.g. shaft). Measure the insulation resistance of the stator and the rotor applying a test voltage of at least 1000 V, and if correct, the serviced or repaired motor can be reassembled.



Before installing the reassembled motor on the machine:

- test the insulation again between phase and earth;
- secure the motor to the bench and, before connecting to the power supply, check that there are no parts incorrectly or insufficiently tightened, liable to injure the operator or damage the motor, or parts connected to the motor;
- connect the motor and any accessories (e.g. electromagnetic brake) to the power supply, following the relative instructions;
- supply the correct voltage to the motor and to components (e.g. brake), checking that the shaft rotates in the required direction and there is no vibration or noise;
- check that the current draw is correct, on the basis of data plate values.

This done, the motor can be installed on the machine.



5.3 DECOMMISSIONING



With regard to the correct handling of Waste Electrical and Electronic Equipment, remember that:

1. waste electrical material must not be disposed of as household refuse, but properly sorted in accordance with local regulations;
2. this item of equipment may contain hazardous substances: improper use or incorrect disposal could have negative effects on human health and on the environment.

Incorrect disposal of WEEE materials is punishable by law.



6 TROUBLESHOOTING

The following table shows a list of abnormal situations that could arise, together with possible remedies and an indication of the person authorized to remedy them.

If a given problem does not appear in the table, contact the C.F.R. engineering department.

Problem	Causes	Remedy	Competency
Electric motor does not start.	No electrical power reaching the motor	Check that the power supply is correct and reaching the contactor or the electronic control (if installed) and that voltage is registering at the motor	Routine maintenance technician
	Incorrect electrical connection	Restore the correct connection	Routine maintenance technician
	Electronic control (if installed)	Check that the control is working and correctly configured Check whether or not there are alarms tripped; if so, remove the cause to restore normal operation of the electronic control	Routine maintenance technician
	Electromagnetic brake (if installed) not releasing	Check that the electronic control or the dedicated brake control device are working correctly and able to release the brake. Check that the brake is correctly calibrated	Routine maintenance technician
	Motor damaged	Contact the C.F.R. engineering department	C.F.R. approved service technician
	Input voltage too high or too low	Check the power supply	Routine maintenance technician
	Resisting torque too high	Disconnect the drive coupling and test the motor under no-load conditions	Routine maintenance technician



Problem	Causes	Remedy	Competency
Motor emits vibration or noise when tested under no-load conditions.	motor malfunctioning	Check that there is no foreign matter inside the motor Check that the brushes are all correctly positioned and in contact with the commutator, and that there is no excessive sparking Check that the motor shaft bearings are not damaged	Routine maintenance technician
	Misalignment and/or incorrect assembly	Check that all components are securely and firmly fastened and there are no bolts loose	Routine maintenance technician
	Rotor and stator touching	Contact C.F.R.	C.F.R. approved service technician
	Damaged, defective or worn bearings	Replace the bearings	Routine maintenance technician
	Fan touching the cowl or other fixed parts of the motor	Locate the point of contact and eliminate	Routine maintenance technician
Excessive power consumption	Possible motor fault	Check that the motor is not damaged Check that the brake (if installed) is fully released Check that there is no mechanical component of the motor seized or damaged, or that there is no misalignment	Routine maintenance technician
	Workload too high	Check that the load factor for the machine is the same as used for selection of the motor size.	Routine maintenance technician
Motor overheating	Fan cowl or ventilation holes occluded or obstructed	Clean thoroughly to restore cooling air flow	Routine maintenance technician
	Input voltage too high or too low	Check the voltage against the data plate	Routine maintenance technician



The manual cannot possibly inform the user as to every potential danger situation that might arise during the operation or maintenance of these electric motors. Accordingly, a sound technical knowledge of the product and of the precautions indicated in this manual — and careful observance of the basic rules regarding safety — can certainly help in anticipating and resolving many danger situations.

Our aim is to help the user adopt and develop safe working procedures, and put them into practice.

Remember: safety is in your interests, and is your responsibility.

