



Blancett[®]
Turbine Flow Meters

Turbine Flow Meter

Model 1100

DESCRIPTION

The Model 1100 turbine flow meter is designed to withstand the demands of the most rigorous flow measurement applications. Originally developed for the secondary oil recovery market, the Model 1100 flow meter is an ideal meter for liquid flow measurement on or off the oil field.

The meter features a rugged 316 stainless steel housing and rotor support assemblies, CD4MCU stainless steel rotor, and abrasive-resistant tungsten carbide rotor shaft and journal bearings. The Model 1100 maintains measurement accuracy and mechanical integrity in the corrosive and abrasive fluids commonly found in oil field water flood projects and many industrial applications.

When paired with a Blancett flow monitor, the Model 1100 turbine meter meets a wide range of measurement requirements. This makes it ideal for applications such as pipelines, production/injection fields, in-situ mining operations, offshore facilities, and other industrial applications. For a full list of Blancett flow monitors, see www.badgermeter.com.

FEATURES

- Offers accurate and repeatable flow measurement in ranges from 0.6...5000 gmp (20...171,000 bpd)
- Cost-effective solution for turbine flow meter applications
- Rugged 316 stainless steel construction offers long service life in severe operating environments
- Available in NPT, BSP, Victaulic[®], flange, or hose barbed end connections
- NIST traceable calibration
- Installation in pipe sizes from 1/2...10 in. Can integrate electronically with a Blancett flow monitor
- K-factor Scaler, or the F to I/F to V Intelligent Converter Field replaceable repair kits allow for turbine replacement without loss of accuracy

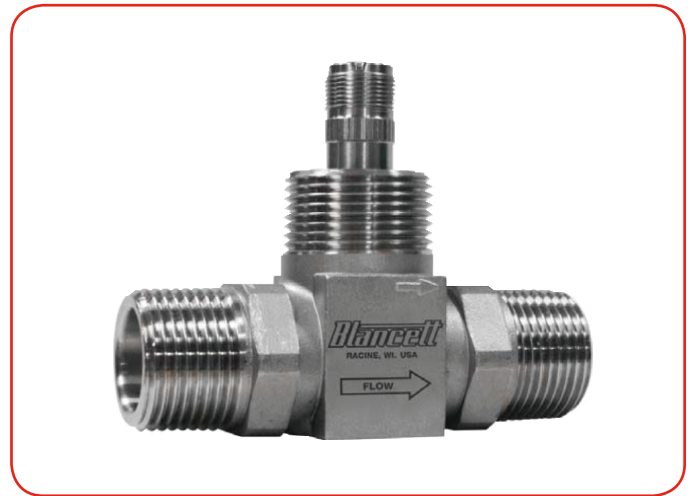

INSTALLATION

The Model 1100 turbine meter is simple to install and service. It operates in any orientation (horizontal to vertical) as long as the "flow direction" arrow is aligned in the same direction as the actual line flow. For optimum performance, the flow meter should be installed with a minimum of 10 diameters upstream straight pipe length and 5 diameters downstream straight pipe length.

REPAIR KITS

The repair kits are designed for easy field service of a damaged flow meter. Model 1100 repair kits replace only the internal parts, rather than replacing the entire flow meter. Repair parts use stainless steel alloys and tungsten carbide construction materials.

Each repair kit is factory calibrated to provide accuracy throughout the entire flow range. Each kit is complete and includes a new K-factor, which is the calibrated number of pulses generated by each gallon of liquid. Recalibration of the monitor or other electronics uses the K-factor to provide accurate output data.



Badger Meter

TRB-DS-01217-EN-05 (September 2018)

Product Data Sheet

OPERATING PRINCIPLE

Fluid entering the meter passes through the inlet flow straightener which reduces its turbulent flow pattern and improves the fluid's velocity profile. Fluid then passes through the turbine, causing it to rotate at a speed proportional to fluid velocity. As each turbine blade passes through the magnetic field at the base of the transducer, an AC voltage pulse is generated in the pickup coil. These pulses produce an output frequency proportional to the volumetric flow through the meter.

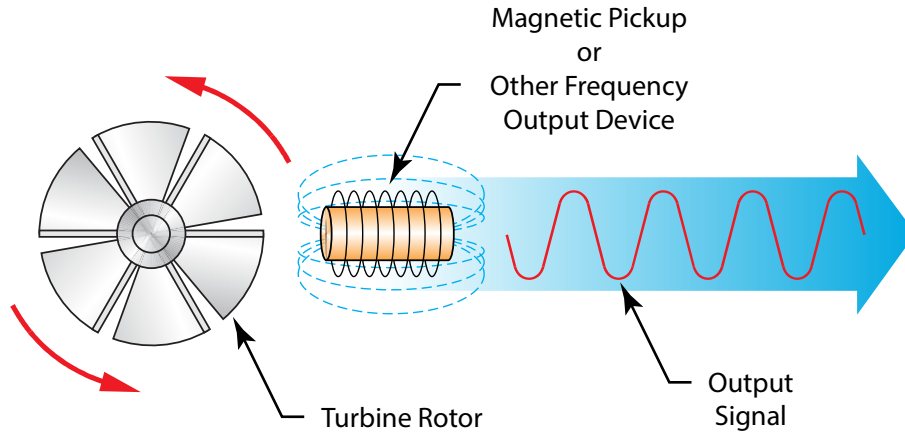

K-FACTOR

The K-factor represents the number of output pulses transmitted per gallon of fluid passing through the turbine meter. Each turbine has a unique K-factor. However, turbine meters are not functionally consistent throughout the full flow range of the meter.

There are several forms of friction inherent in the turbine meters that retard the rotational movement of the turbine rotor. These frictional forces include: magnetic drag, created by electromagnetic forces of pickup transducers; mechanical drag, due to bearing friction; and viscous drag, produced by flowing fluid.

As flow increases, the frictional forces are minimized and the free-wheeling motion of the turbine rotor becomes more linear (proportional to flow). The K-factor becomes relatively constant and the linear throughout the balance of the linear flow range. This is approximately a 10:1 turndown ratio from the maximum flow rate down to the minimum flow rate.

Typical K-factor Curve (Pulse per US Gallon)

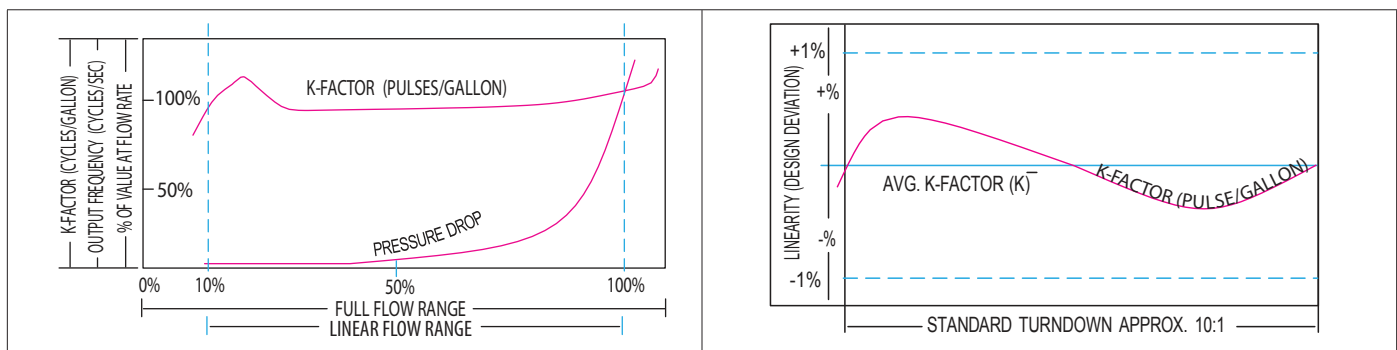

SPECIFICATIONS

Materials of Construction	Body	316 stainless steel
	Rotor	CD4MCU stainless steel
	Bearings	—
	Rotor Shaft	Tungsten carbide
	Rotor Support	316 stainless steel
Operating Temperature	-150...350° F (-101...177° C)	
Pressure Rating	800 or 5000 psi	
End Connections	NPT, BSP, Victaulic®, flange, hose barbed	
Turndown Ratio	10:1	
Accuracy	±1% of reading for 7/8 in. and larger meters	
	±1% of reading over the upper 70% of the measuring range for 3/8, 1/2, and 3/4 in. meters	
Repeatability	±0.1%	
Calibration	Water (NIST traceable calibration)	
Pickup	B111109	
Certifications	CSA Class I Div 1, Groups C & D Class II Div 1, Groups E, F & G: intrinsically safe*	
	CSA Class I Div 1 Groups C,D; complies to UL 1203 and CSA 22.2 No. 30	
	Met Labs File No. E112860 (for explosion proof models only)	

* Contact factory for ordering options

METER PARTS

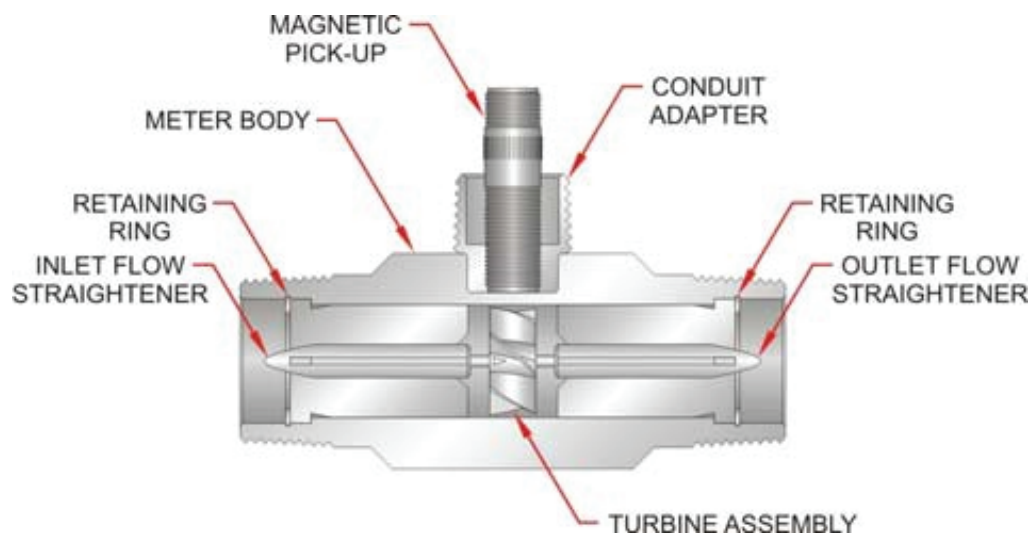

PART NUMBER INFORMATION

Part Number	Bore Size	End Connection	Max. PSI	Flow Ranges			Strainer Mesh	Approx. K-factor Pulse/Gal	Meter Weight (lb)	End to End Length
				gpm (lpm)	bpd	m ³ /d				
B110-375-½	3/8 in. (9.5 mm)	1/2 in. male NPT	5000	0.6...3 (2.3...11.4)	20...100	3.3...16	60	18000	1	3.00 in. (76.20 mm)
B110-500-½	1/2 in. (12.7 mm)	1/2 in. male NPT	5000	0.75...7.5 (2.8...28.4)	25...250	4.1...41	60	13000	1	3.00 in. (76.20 mm)
B110-750-½	3/4 in. (19.1 mm)	1/2 in. male NPT	5000	2...15 (7.6...56.7)	68...515	10.9...81.75	60	3300	1	3.00 in. (76.20 mm)
B110-375	3/8 in. (9.5 mm)	1 in. male NPT	5000	0.6...3 (2.3...11.4)	20...100	3.3...16	60	18000	2	4.00 in. (101.60 mm)
B110-500	1/2 in. (12.7 mm)	1 in. male NPT	5000	0.75...7.5 (2.8...28.4)	25...250	4.1...41	60	13000	2	4.00 in. (101.60 mm)
B110-750	3/4 in. (19.1 mm)	1 in. male NPT	5000	2...15 (7.5...56.7)	68...515	10.9...81.75	60	3300	2	4.00 in. (101.60 mm)
B110-875	7/8 in. (22.2 mm)	1 in. male NPT	5000	3...30 (11.4...113.6)	100...1000	16...160	60	3100	2	4.00 in. (101.60 mm)
B111-110	1 in. (25.4 mm)	1 in. male NPT	5000	5...50 (18.9...189.3)	170...1700	27.25...272.5	40	870	2	4.00 in. (101.60 mm)
B111-115	1-1/2 in. (38.1 mm)	1-1/2 in. male NPT	5000	15...180 (56.8...681.4)	515...6000	82...981	20	330	5	6.00 in. (152.40 mm)
B111-121	1-1/2 in. (38.1 mm)	2 in. male NPT	5000	15...180 (56.8...681.4)	515...6000	82...981	20	330	6	6.00 in. (152.40 mm)
B311-066	1-1/2 in. (38.1 mm)	2 in. grooved end	5000	15...180 (56.8...681.4)	515...6000	82...981	20	330	6	6.00 in. (152.40 mm)
B111-120	2 in. (50.8 mm)	2 in. female NPT	5000	40...400 (151.4...1514.2)	1300...13000	218...2180	20	52	14	10.00 in. (245.00 mm)
B311-004	3 in. (76.2 mm)	3 in. male NPT	800	60...600 (227.1...2271.2)	2100...21000	327...3270	10	57	15	12.50 in. (317.50 mm)
B111-130	3 in. (76.2 mm)	3 in. grooved end	800	60...600 (227.1...2271.2)	2100...21000	327...3270	10	57	15	12.50 in. (317.50 mm)
B311-084	4 in. (101.6 mm)	4 in. male NPT	800	100...1200 (378.5...4542.5)	3400...41000	545...6540	10	29	20	12.00 in. (304.80 mm)
B111-140	4 in. (101.6 mm)	4 in. grooved end	800	100...1200 (378.5...4542.5)	3400...41000	545...6540	10	29	20	12.00 in. (304.80 mm)
B311-085	6 in. (152.4 mm)	6 in. male NPT	800	200...2500 (757.1...9463.5)	6800...86000	1090...13626	4	7	46	12.00 in. (304.80 mm)
B111-160	6 in. (152.4 mm)	6 in. grooved end	800	200...2500 (757.1...9463.5)	6800...86000	1090...13626	4	7	46	12.00 in. (304.80 mm)
B111-180	8 in. (203.2 mm)	8 in. grooved end	800	350...3500 (1324.9...13248.9)	12000...120,000	1363...19076	4	3	56	12.00 in. (304.80 mm)
B111-200	10 in. (254 mm)	10 in. grooved end	800	500...5000 (1892.7...18927.1)	17000...171,000	2725...27252	4	1.6	80	12.00 in. (304.80 mm)

¹ Includes Standard Mag Pickup, p/n B1111109, -150...330° F (-101...165° C), suitable for all mounting styles