

SOLENOID GAS VALVES WITH 1/8" and 1/4" CONNECTIONS AND OPERATING PRESSURE UP TO 1,5 bar.

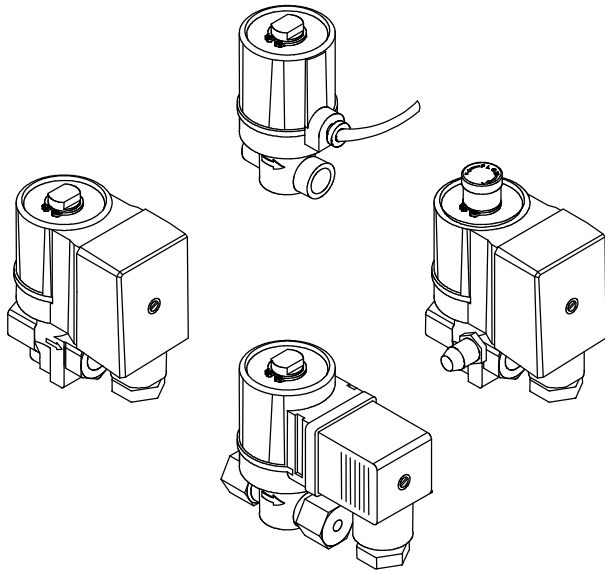

GENERAL DESCRIPTION

This series of solenoid valves are of normally closed type, suitable for civil and industrial applications, supplied with alternate or direct current.

E8/S version, which can be fitted with a flow adjustment device and outlet pressure plug, are supplied with alternate current, but provided with an inside rectification circuit, which permitted to make actions as silent as possible.

Gas valves of this series, conforming to EN161, have a CE type Certificate (CE Reg. N° 63AQ0626) in accordance to European directives 90/396 and 93/68.

- EC- type certification in accordance with the new European Gas Appliances Regulation (EU) 2016/426 (GAR);
- conformity to EC Low-voltage directive 2014/35/EU

TECHNICAL FEATURES

Class:	A
Group:	2
Supply voltage (1):	230Vac / 50-60Hz 110Vac / 50-60Hz
Operating temperature:	-10°C / +60°C
Closing time:	≤ 1s
Opening time:	≤ 1s
Mounting:	vertical and horizontal
Body:	die-cast brass

(1) Versions with different supply voltages are available.

DIRECTIONS FOR INSTALLATION AND MAINTENANCE

- This valve is a safety appliance and should not be modified. The manufacturer's responsibility and guarantee are invalidated in case the device is tampered with by the user.
- The applicable national regulation and European standards (Ex. EN 60335-1 and EN 60335-2-102) related to the electrical safety must be respected.
- Assemble the valve to the installation so that the arrow on the valve body has the same direction as the fuel flow.
- During the assembly of the valve to the installation piping, avoid twisting on the sheath and always use an hexagonal wrench to be fitted to the valve body.
- Make sure that no foreign matters have entered the valve body.
- Make sure that the max. fuel input pressure never exceeds the value appearing on the label.
- All operations (installation, maintenance, etc.) must be carried out by a qualified technician.
- Before any connection operation, completely isolate the system from power supply (multi-pole disconnection). Place the system safely to avoid accidental switch-on and make sure there is no voltage. If the system is not switched off, there is a risk of electric shock.
- During and after any operation (installation, maintenance, etc.), make sure that the type and code are the ones provided, check the correct functioning and the internal and external thickness of the valve.
- In the event of a fall or impact, the valves must not be started, as safety functions may be compromised even if no damage is visible to the outside.
- Faulty valves or damaged must be unplugged from power supply and cannot be used.
- The valve has a designed lifetime* based on the endurance tests in the standard EN 161. A summary of the conditions has been published by the European Control Manufacturers Association (Afecor) (www.afecor.org). The designed lifetime is based on use of the valve according to the manufacturer's technical notes. After reaching the designed lifetime in terms of the number of burner startup cycles, or the respective time of usage, the valve has to be replaced by authorized personnel.

* The designed lifetime is not the warranty time specified in the Terms of Delivery

FLOW ADJUSTMENT FOR E8/SR...

After removing the top protection, rotate clockwise the screw marked with 1 in Fig.1 to reduce the flow, rotate it counter clockwise to increase the same.

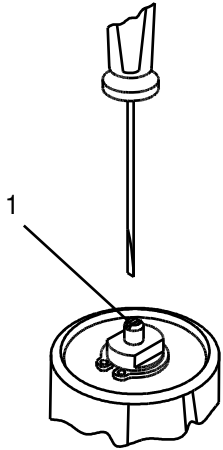
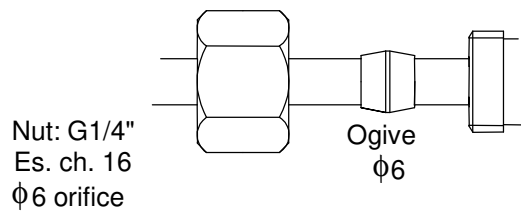
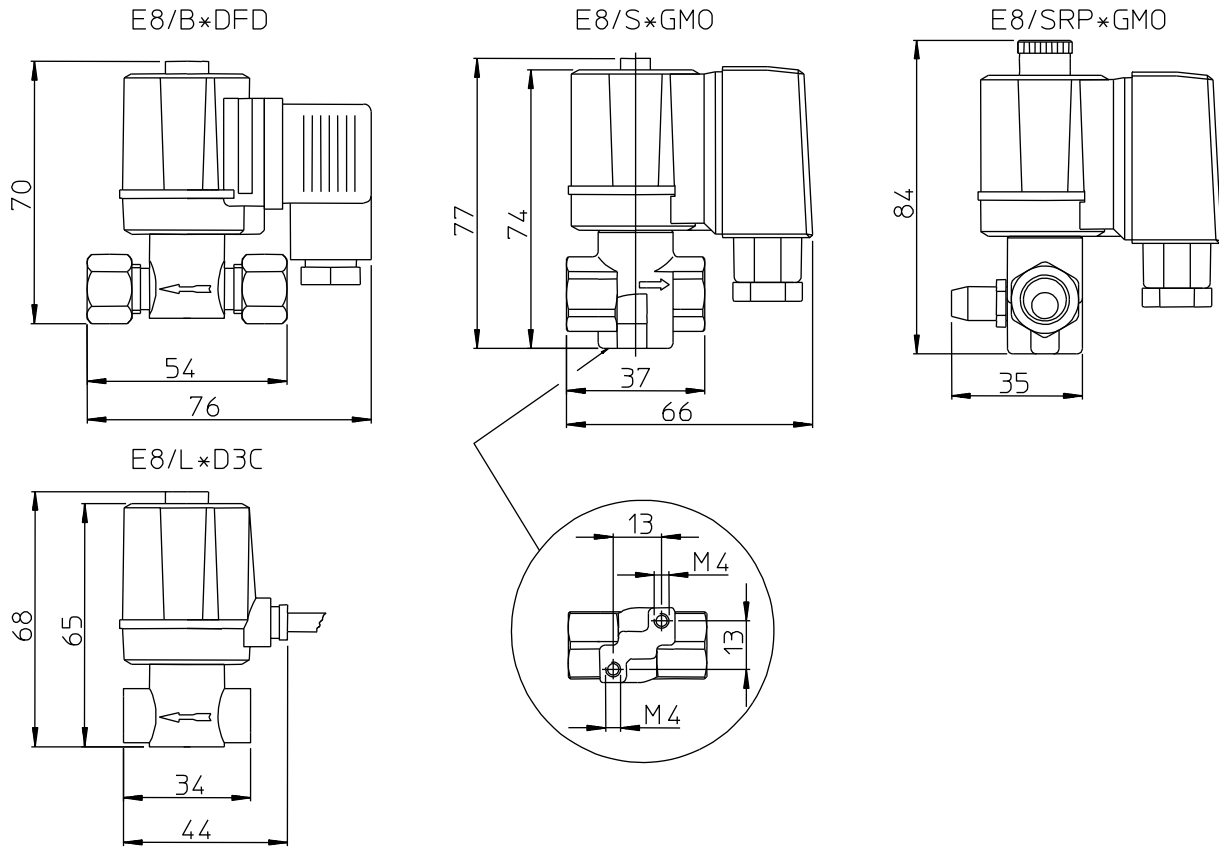

Fig.1

E8/B FIXING



OVERALL DIMENSIONS



ELECTRICAL CONNECTION

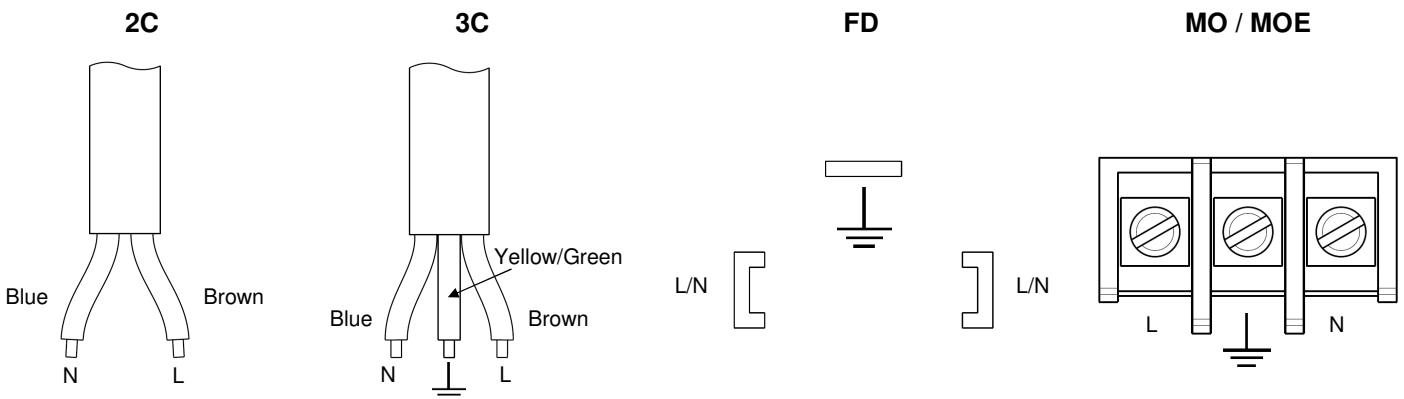

DIAGRAM

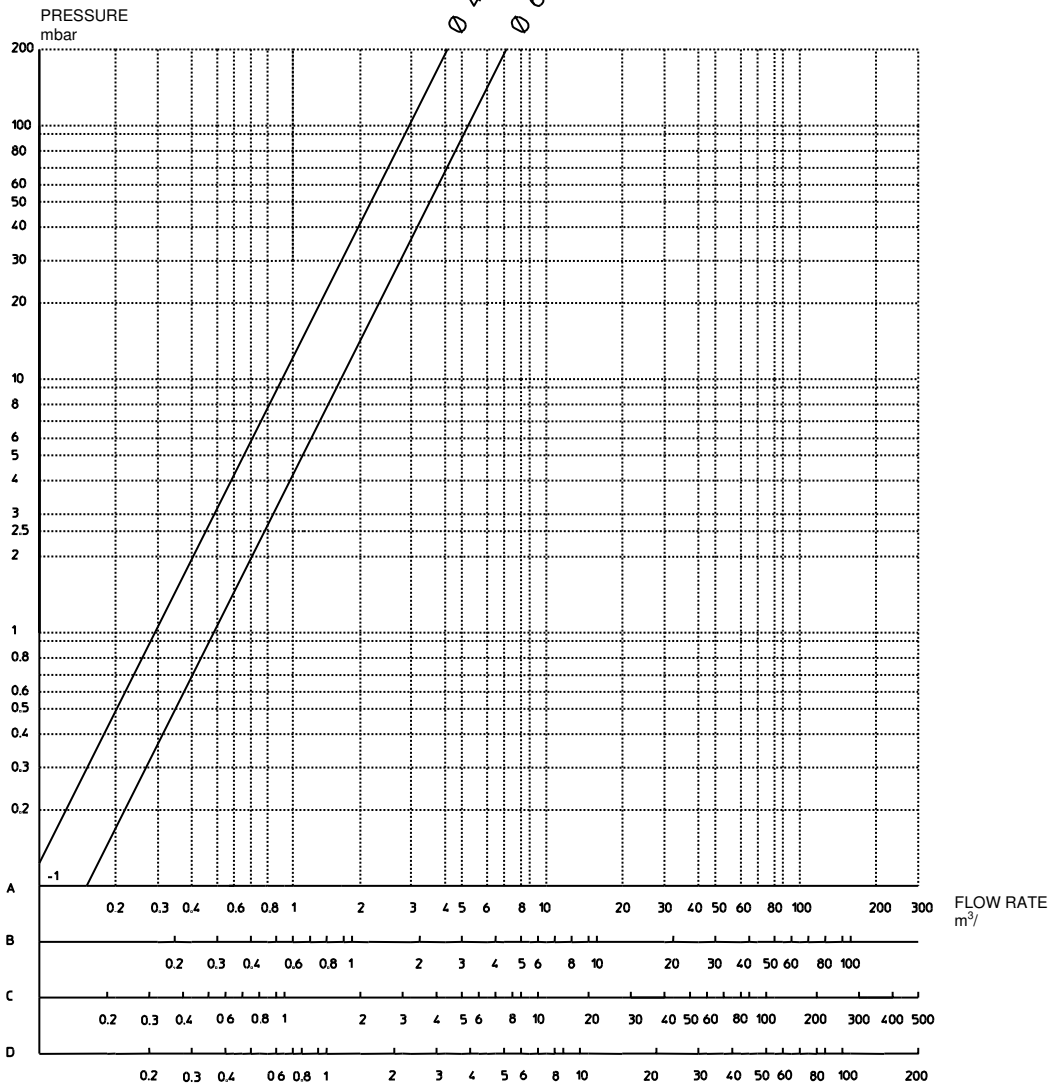

A: standard flow rate m³/h of NATURAL GAS dr 0.554
 B: standard flow rate m³/h of LPG dr 1.54
 C: standard flow rate m³/h of TOWN GAS dr 0.411
 D: standard flow rate m³/h of AIR dr 1

SUMMARY TABLE

Type	DN	Operating pressure (mbar)	Orifice diameter (mm)	Connection	Weight (g)	Coil	Consumption (VA)		Flow (m ³ /h gas with ΔP 2.5mbar)	Possibility to fit pressure test point
							230Vac	110Vac		
E8/B	8	0 ÷ 1500	4	1/4" M	243	BE7*D3C	10	10	0.5	No
E8/B	8	0 ÷ 1500	4	1/4" M	222	BE7*DFP	10	10	0.5	No
E8/B	8	0 ÷ 1500	4	1/4" M	222	BE7*DFD+MPM182	10	10	0.5	No
E8/B	8	0 ÷ 1500	4	1/4" M	243	BE7*C3C	7	7	0.5	No
E8/B	8	0 ÷ 1500	4	1/4" M	222	BE7*CFP	7	7	0.5	No
E8/B	8	0 ÷ 1500	4	1/4" M	222	BE7*CFD+MPM182	7	7	0.5	No
E8/L	6	0 ÷ 1500	4	1/8" F	230	BE7*D3C	10	10	0.5	No
E8/L	6	0 ÷ 1500	4	1/8" F	220	BE7*DFP	10	10	0.5	No
E8/L	6	0 ÷ 1500	4	1/8" F	220	BE7*DFD+MPM182	10	10	0.5	No
E8/L	6	0 ÷ 1500	4	1/8" F	230	BE7*C3C	7	7	0.5	No
E8/L	6	0 ÷ 1500	4	1/8" F	220	BE7*CFP	7	7	0.5	No
E8/L	6	0 ÷ 1500	4	1/8" F	220	BE7*CFD+MPM182	7	7	0.5	No
E8/S	8	0 ÷ 100	6	1/4" F	280	BE7*GMO	7	7	0.8	Yes
E8/S	8	0 ÷ 100	6	1/4" F	260	BE7*C3C	7	7	0.8	Yes
E8/S	8	0 ÷ 100	6	1/4" F	250	BE7*CFP	7	7	0.8	Yes
E8/S	8	0 ÷ 100	6	1/4" F	250	BE7*CFD+MPM182	7	7	0.8	Yes
E8/S	8	0 ÷ 100	6	1/4" F	250	BE7*CFD+MPM532	7	7	0.8	Yes
E8/SR	8	0 ÷ 100	6	1/4" F	290	BE7*GMOE	13	7	0.8	Yes
E8/SRP	8	0 ÷ 100	6	1/4" F	290	BE7*GMOE	13	7	0.8	Yes

TYPE REFERENCES

E8 / S R P * G MO 230/50-60

Type _____

Body type _____

Body	Connections	Orifice
B	G1/4" M	4 mm
L	G1/8" F	4 mm
S	G1/4" F	6 mm

Flow adjustment _____

Valve fitted with equipment for flow adjustment.

Pressure plug _____

Valve inclusive of pressure plug.

Supply voltage

Type	Description
110/50-60	110Vac/50-60Hz
230/50-60	230Vac/50-60Hz

Connection type

Type	Description
2C	Connection with two core cable-IP65.
3C	Connection with three core cable-IP65.
FD	Connection with fast-on for plug DIN43650-IP65.
MO	Connection with terminal board-IP40.
MOE	Connection with terminal board for valve inclusive of flow adjustment-IP40.

Winding type

Type	Description
A	Supply in alternate current.
B	Supply in alternate current with use of two external diodes: the first in series to the coil, the other in parallel to it.
C	Supply in direct current.
D	Supply in alternate current, but valve operates in direct current thanks to two embodied diodes.
G	Supply in alternate current, but valve operates in direct current thanks to an embodied rectification bridge.



NOTES FOR THE DISPOSAL OPERATION

The controller contains electronic components and it must not be disposed of as a domestic waste. For the disposal operation refer to the local rules concerning special waste.

ATTENTION --> Company Brahma S.p.A. declines any responsibility for any damage resulting from Customer tampering with the device.

BRAHMA S.p.A.

Via del Pontiere, 31
 37045 Legnago (VR) - ITALY
 Tel. +39 0442 635211 - Fax +39 0442 25683
<http://www.brahma.it>
 E-mail : brahma@brahma.it

04/11/2022 Subject to amendments without notice