



# **EE310 Electromechanical Level Measuring System Operation Manual**

**FineTek Co.,Ltd.**

No.16, Tzuchiang St., Tucheng Industrial Park, New Taipei City 23678

Tel : 886-2-22696789

Fax : 886-2-22686682

Website : <http://www.fine-tek.com>

E-mail : [info@fine-tek.com](mailto:info@fine-tek.com)

08-EE310-B4-EK,04/07/2022

## Warning



- Be sure to power off before wiring.
- Do not touch any wire terminal during power on to avoid electrical shock and always keep the screws secured.
- Connect the wires to the terminal in the correct order on the wiring diagram.
- Repairing, modifying, or taking apart the product will void the guarantee.
- Never place this product near any environment with explosion or flammable gas atmosphere concerns.
- User should check the power supply if it is within operation range and keep from over range operation.
- Never operate instrument near flammable gas, and liquid environment.
- Avoid exposure to vibration, high temperature, high humidity, sunlight, and high frequency machine operation environment.
- To get long life operation, it is suggested to install cooling system with your system.

## Before Using This Product



- Check if the content is the order model you expected.
- Avoid exposure to shock, vibration or dropping the product.
- Suggested warm up time is over 30 minutes before operation if user is concerned with accurate temperature compensation.

## Product Mounting



- Should not mount in a location that is easy to freeze, dusty or comes in contact with corrosion gas.
- Avoid placing the product in high temperature fluctuation environment, and keep away from high temperature environment ( $>55^{\circ}\text{C}$ ).
- Check if any device will create high electric interference nearby – adopt appropriate isolation, grounding or filtering power line if necessary.

# Contents

1. Instruction.....	1
2. Guarantee .....	1
2.1. New product warranty.....	1
2.2. Maintenance warranty.....	1
2.3. Service Network .....	2
3. Introduction .....	3
3.1. Product Features.....	3
3.2. Principle .....	3
3.3. Sketch & Drawing.....	4
3.4. Applications.....	4
4. Specifications.....	5
4.1. Technical Parameters.....	5
4.2. Product Specifications .....	6
4.3. Product Dimension .....	7
5. Product Examination .....	7
5.1. Disassembly .....	7
5.2. Handling Instructions .....	7
6. Installation .....	8
6.1. Location Selection .....	8
6.2. Installation Instruction.....	9
6.3. Caution.....	9
6.4. Wiring Instruction.....	10
7. Operation .....	12
7.1. Panel.....	12
7.2. Operation flowchart .....	13
7.3. Communication .....	15
7.4. Setting Procedure .....	17
7.5. Definition.....	17
8. Maintenance .....	19
8.1. Regular Maintenance .....	19
8.2. Cable Wire Replacement.....	19
9. Troubleshooting .....	22

# 1. Instruction

Thank you for purchasing FineTek product. This user manual will introduce the product features, operations, maintenance and troubleshooting to help the user get familiar with the product, and avoid possible hazardous situations. Before operating this device, please carefully study the product details. Additional support can be found at [www.fine-tek.com](http://www.fine-tek.com) or contact your local representative by telephone and facsimile. Online revisions will be posted on the web site only. Users can get newest support and download information at [www.fine-tek.com](http://www.fine-tek.com). In case of any unexpected problem, don't disassemble the product by yourself as this will void the product guarantee. If you have any question, don't hesitate to contact us.

## Symbol Instruction



DANGER indicates a hazardous situation which, if not avoided, will result in death or serious injury.



ATTENTION indicates a hazardous situation which, if not avoided, will result in injury and damage to the equipment.



Wrong operation will result in electric shock.



Keep away from flammable materials or keep in an electrical safe environment.



Forbidden operation

# 2. Guarantee

All FineTek products will get one year guarantee under normal operating conditions. Product within the guarantee period will receive service at no charge. Any defect during delivery process or damage not by wrong operation, user can ask for a return or replacement. User has the obligation to send all complete parts back to FineTek carefully packaged. Over range of operation, overvoltage or any abnormal operation will void the guarantee period. Product out of the guarantee period, will be charged the necessary fees for repair or replacement.

## 2.1. New product warranty

Things below will not in guarantee coverage and will be charged service fee:

- Expiration of the guarantee period.
- Improper installation and use according to the operation manual.
- Natural hazards effects or natural disaster (earthquake, flood disaster, fire, lighting strike, hurricane, etc.)
- User abuse and damage (scratch, cutting, throwing down, hammering, etc.) or abnormal operation (over power range, over ambient condition, over range operation, corrosion, water damage, electric charge), non-approved third-party device connection, expansion, or non-approved components replacement.

## 2.2. Maintenance warranty

All products will get six months guarantee service after repair or components replacement. During the six months, any fault caused in same will be serviced in free charge.

## 2.3. Service Network

Company	Address	Telephon	Fax
Taipei Headquarters (Taiwan)	No.16, Tzuchiang St., Tucheng Industrial Park, New Taipei City 23678	+886 2-2269-6789	+886 2-2268-6682
Taichung Sales office (Taiwan)		+886 4-2465-2820	+886 4-2463-9926
Kaohsiung Sales office (Taiwan)		+886 7-333-6968	+886 7-536-8758
Fine automation Co., Ltd. (China)	No. 451, Duhui Road, Zhuanqiao Township, Minhang District, Shanghai City 201109	+86 021-64907260	+86 021-6490-7276
FineTek Pte Ltd. (Singapore Branch)	37 Kaki Bukit Place, Level 4 Singapore 416215	+65 6452-6340	+65 6734-1878
FineTek GmbH (Germany Branch)	Bei den Kämpen 26 21220 Seevetal-Ramelsloh, Germany	+49 (0) 4185 8083 0	+49 (0) 4185 8083 80
FineTek Co., Ltd. (Indonesia Branch)	PERGUDANGAN TUNAS BITUNG JL. Raya Serang KM. 13,8, Blok C3 No. 12&15, Bitung Cikupa, Tangerang 15710	+62 021-2958-1688	+62 021-2923-1988

## 3. Introduction

### 3.1. Product Features

- Measurements are independent of environment variation (sound waves, dust, capacitance, humidity and temperature), and is suitable for various industrial applications.
- User-friendly operation and full functionalities with microprocessor control.
- Relay output (5A/240Vac)×4: HI, LO alarm or Pulse, Reset, fault alarm, operation indication or Lock alarm output can be programmed.
- LCM Graphic 128x64 Dots
- Analog output: 0-20mA / 4-20mA.
- Pulse output: Transistor output (NPN/PNP).
- Cable Break Alarm: System will detect automatically when cable is broken during operation.
- Sensing Weight Buried Alarm: System will detect automatically when the sensing weight is buried in the measured material.
- Four Detection Modes:
  - I. Auto operation: in period, system will be waked up in certain time period depend on the pre-setting.
  - II. Manual operation: User can operate system at front panel to set procedure any time.
  - III. Intelligent (smart) operation: The EE310 will vary its detection frequency to shorten the measuring time while the detected material level is more far away from EE310. This function is especially useful while customer's storage or reservoir is subjected fast change in level (Ex: Pour in / Pour out), this smart function will decrease the possibility of weight head be buried or malfunction.
  - IV. External trigger operation: Support external command to start on the system.
- Auto Return Setup: User can set the sensing level threshold and force the system return at the preset threshold value. This function is especially of service while the measured material in storage or reservoir is lower than the threshold level, which will be in prevention away of damaging facility.
- Material Fill-Up Protection: While user's facility is on pour into material status, the system will be triggered (By Fill-Up Protection Input) hold and return to its original to reduce the malfunction or weight head buried possibility.
- Maximum measuring range of 30m.
- RS485 communication protocol available.
- Versatile sensing weight structure satisfy customer's requirement.
- Froze Protect: Within the EEX, it supports a heat element to warm up the electric board within shell housing to guarantee it will work normally even under severe cold environment.

### 3.2. Principle

EE310 series Electro-Mechanical Level Measuring System consists of a sensing weight, a cable wire, a pulley set with Hall sensor to count level distance, and a calculating electric board. While measuring, the drooping cable wire will drive the pulley set in rotation, where the Hall sensor will count the number of pulley rotation as an index. The electric board will calculate the pulse command sent to motor, and the actual drooping length can be transferred by pulse command and the rotation number of pulley. All data displayed at the front panel, can be transferred to output.

### 3.3. Sketch & Drawing

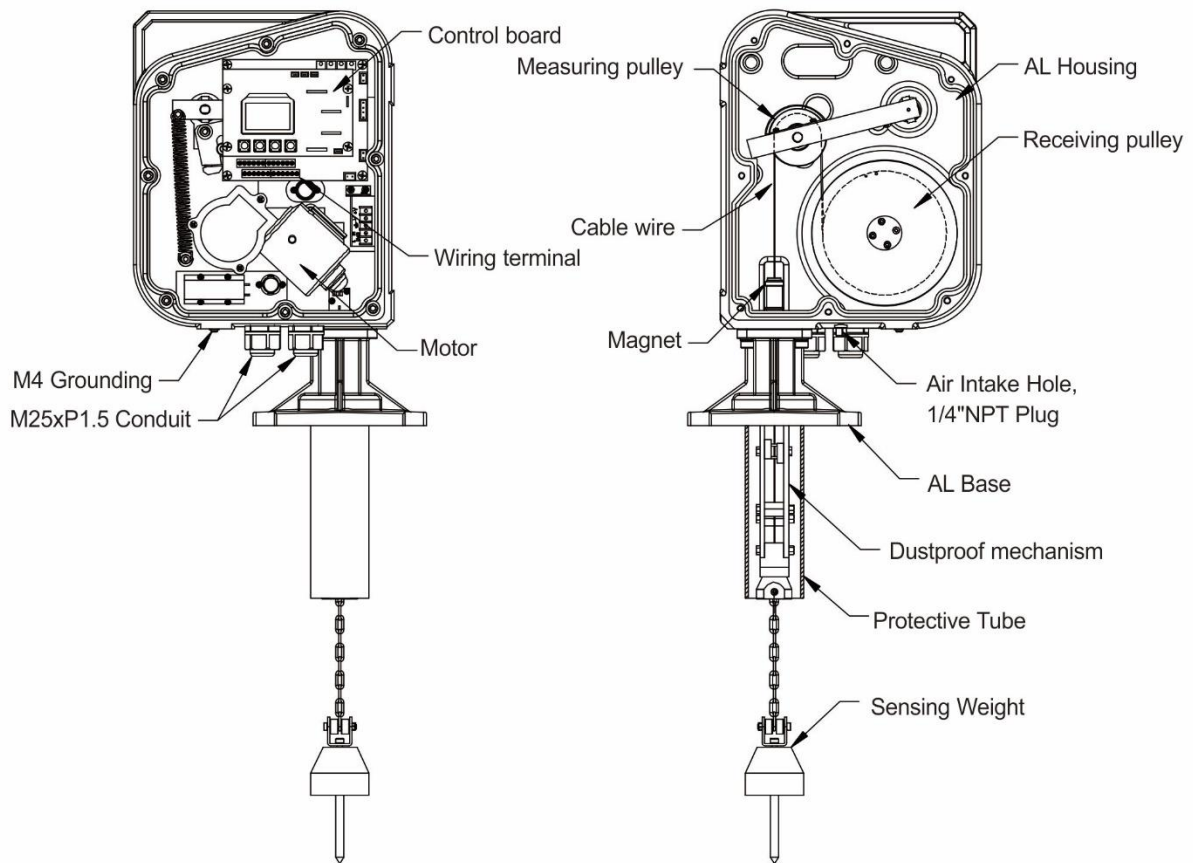

Front View: Electric Board & Motor

Rear View: Wiring Mechanism

### 3.4. Applications

- Measurements are independent of environment variation (sound waves, dust, capacitance, humidity and temperature, and is suitable for various industrial applications.
- Typical applications like metallurgical industry, mining, cement industry, power plant, ship manufacturing industry, chemical industry, feed industry, food industry etc.
- Control process is compatible with the need of general power, pellet, lump or bulk material monitoring.
- Standard output can be further connected with customer's central managing system.

## 4. Specifications

### 4.1. Technical Parameters

NO.	Category	Specification		
1	Power Supply	100~240Vac, $\pm 10\%$ 50/60 Hz (Standard) 24Vdc $\pm 10\%$ (By order)		
2	Measuring Resolution	Transistor output NPN / PNP $\pm 5$ pulse(10mm/pulse) Relay output $\pm 1$ pulse(100mm/pulse)		
3	Measuring Speed	Avg. 0.23m/s		
4	Analog Output	0/4-20mA $\pm 1\%$		
5	Pulse Output	NPN/PNP output : max. 60Vdc, max. 400mA ※ When the counter is connected, the pulse extraction rate needs to be $> 50$ Hz. Relay output (dry contact): ※ When the counter is connected, the pulse extraction rate needs to be $< 30$ Hz.		
6	Relay output	SPDT 5A/240Vac X4 Relay 1 : Pulse / HI Alarm (can be set up) Relay 2 : Reset / LO Alarm (can be set up) Relay 3 : Failure Relay 4 : Run Signal / Lock (can be set up)		
7	Status LED	Indication for Power Run Signal Abnormal		
8	Display	LCM Graphic 128x64 Dots		
9	Ambient Temperature	$-40^{\circ}\text{C} - 60^{\circ}\text{C}$		
10	Operating Temperature	$-40^{\circ}\text{C} - 80^{\circ}\text{C}$		
11	Measuring Range	30m Max		
12	Protection Level	IP66		
13	Body material	Aluminum		
14	Anti-Dew Heater (Optional)	Start heating $< 16^{\circ}\text{C}$ ( prevent frostbite, prevent dew )		
15	Cable Break Detection	Yes		
16	Sensing Weight Buried Detection	Yes		
17	Manual/Auto Measuring Mode	Yes(0.1-99h)		
18	Motor Protection	Yes		
19	Malfunction Diagnosis Display	Yes		
20	Material Fill-Up Protection	Yes		
21	External trigger start	Yes		
22	Communication Protocol (RS485)	Yes	Baud rate	9600.19200.38400.57600
23	Intelligent Start	Measuring interval is inverse proportional to medium level.		
24	Reset Output	Yes		
25	Cable Wire	$\phi 1.2$ mm		



## 4.2. Product Specifications

- Power supply (Options) : AC type: 100~240Vac, ±10% 50/60Hz  
DC type: 24Vdc ±10%
- Power Consumption at Stand-by: 6VA
- Display : LCM Graphic 128x64 Dots
- Analog output : 0/4~20mA, support bi-direction arrangement (High level for maximum current output and low level for minimum current output, or vise verse. )
- Relay Alarm: SPDT 5A/240Vac, 2A/48Vdc x4
- Operation Temperature: -40°C~ 80°C
- Ambient Temperature: -40°C~ 60°C
- Material: Body --- Aluminum , Cable Wire --- SUS 304 (Φ1.2mm)
- Flange : □180
- Measurement Range: 1~30m
- Total Weight: 13kg
- Sensing Weight Type :

Code	A	B	C	D
Name	Standard type Stainless steel	Float type Stainless steel	Umbrella Stainless steel	Auto-Fall-Off Plastic
Type				

※ Custom made is available for sensing weight

- Sensing Weights Materials & Application:
  - I. Type A: Standard type; Materials: Stainless steel,  
Application: For coarse bulk solids, e.g. coals, ores, fly ash or stones and granulated.
  - II. Type B: Float type; Materials: Stainless,  
Application: For Liquid applications.
  - III. Type C: Umbrella type; Materials: Stainless,  
Application: For very light and loose bulk solids, e.g. flour or coal-dust.
  - IV. Type D: Plastic Auto-Fall-Off; Materials: HDPE;  
Application range: With Auto-Fall-Off function of overweight, the damage caused by the pulling or buried wire into the material can be avoided- the material filled inside this weight may not contaminate the detected material. It is suitable for powder, granular and coarse bulk solids, such as food, feed, coal, ore or stone.

### 4.3. Product Dimension

(unit: mm)

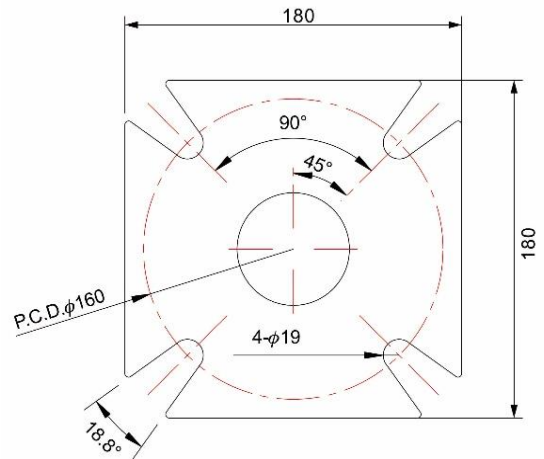
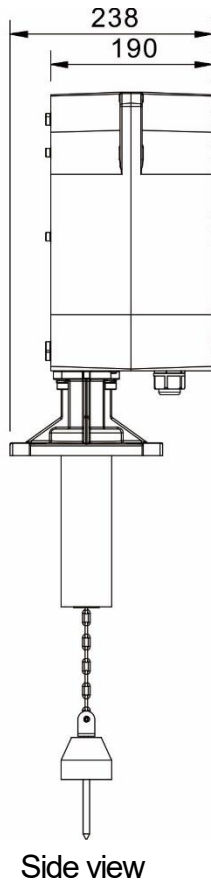
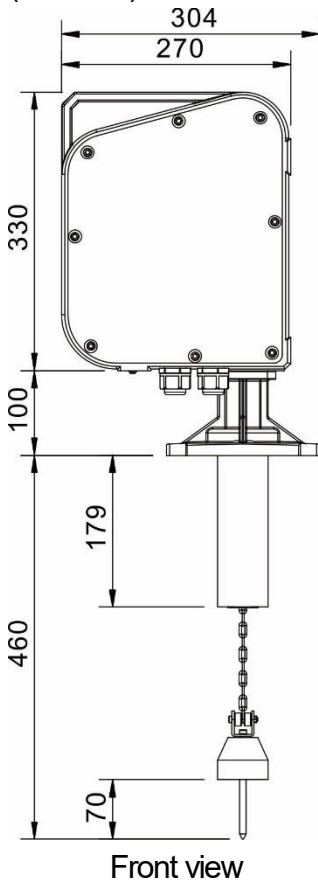

※ Flanges For Standard Model:  
 4"x5kg/cm<sup>2</sup> · 4"x10kg/cm<sup>2</sup> · 4"x16kg/cm<sup>2</sup> ·  
 4"x20kg/cm<sup>2</sup> · 4"x150Lbs · DN100 PN6 ·  
 DN100 PN10 · DN100 PN16 · DN100  
 PN25 · DN100 PN40

## 5. Product Examination

### 5.1. Disassembly



- 5.1.1. Before disassembly, please carefully check if the packaging is damaged. Please take photos for any broken or deformed packaging as a witness for proper compensation.
- 5.1.2. Check that the package includes all the parts; any missing or broken items will only be accepted and compensated or replaced with a new one according to the witness of capture photo.
- 5.1.3. Please contact us and provide claim with photos within 7-days after acceptance. FineTek guarantees after service and maintenance according to the purchase order. Over 7-days, it is regarded as acceptance of well delivery.

### 5.2. Handling Instructions



- 5.2.1. The product should be moved and handled carefully and not be subject to any press or abnormal throwing down.
- 5.2.2. Don't pull and drag the cable wire or hammer the weight head as it will damage the product.
- 5.2.3. When installing the product at 3 m above ground or higher, it is suggested to operate with hoist.

## 6. Installation



### 6.1. Location Selection

6.1.1. Installation position should be away from the inlet or outlet of reservoir at least 1.2 m, and avoid locations interfering with the conveying system to avoid damage to the facility.

6.1.2. Reservoir or tank equipped with observation window is suggested; it will be beneficial for future maintenance. The installation location should be away from the ladder, frame or any protrusion. The minimum distance between the EEX center and tank wall should be 1m or more.

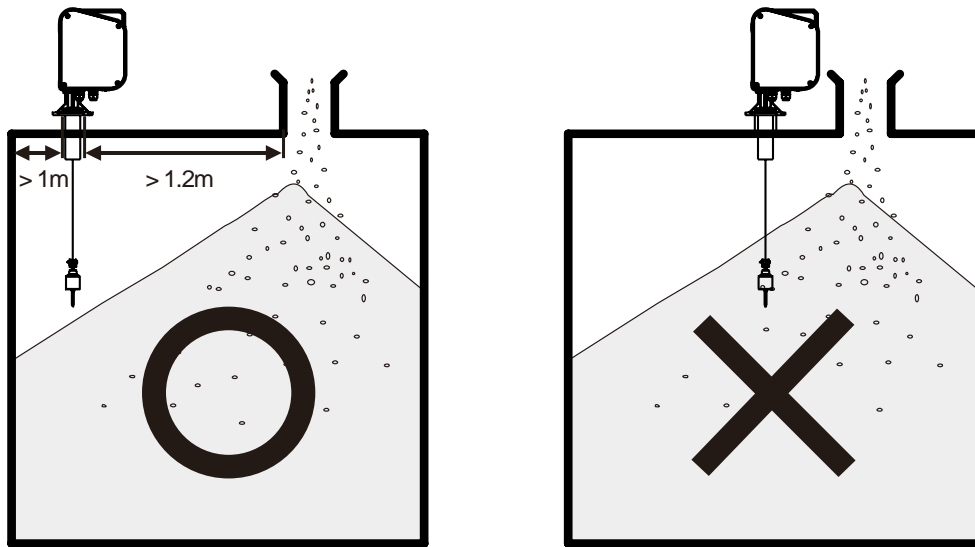

6.1.3. Must be located away from the inlets flow direction to avoid the cable and hammer being damaged by material or disconnected or buried.

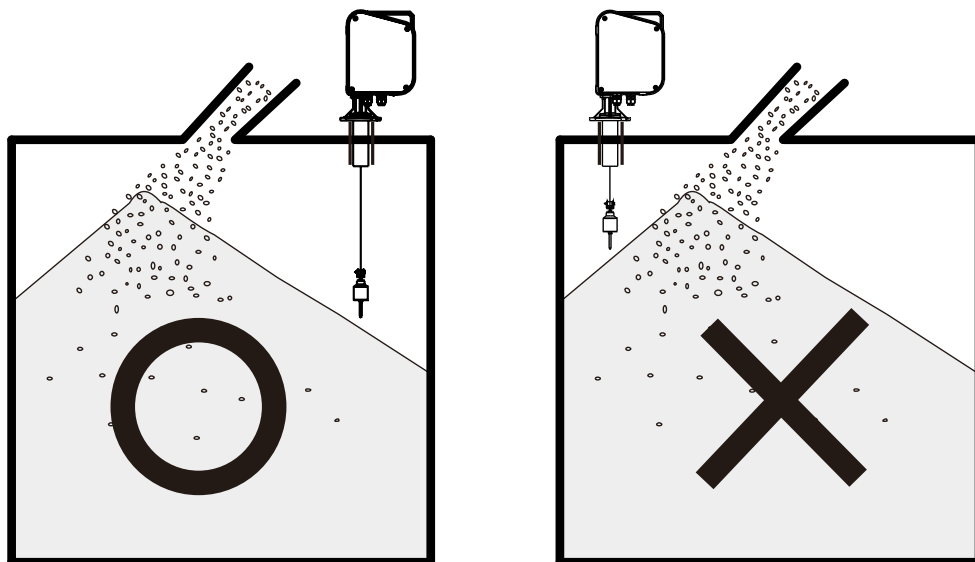

6.1.4. The optimal position is at the average depth of measured material, it will generally locate at mountainside between the peak and bottom (the cone angle from by the pouring process), indicates below.

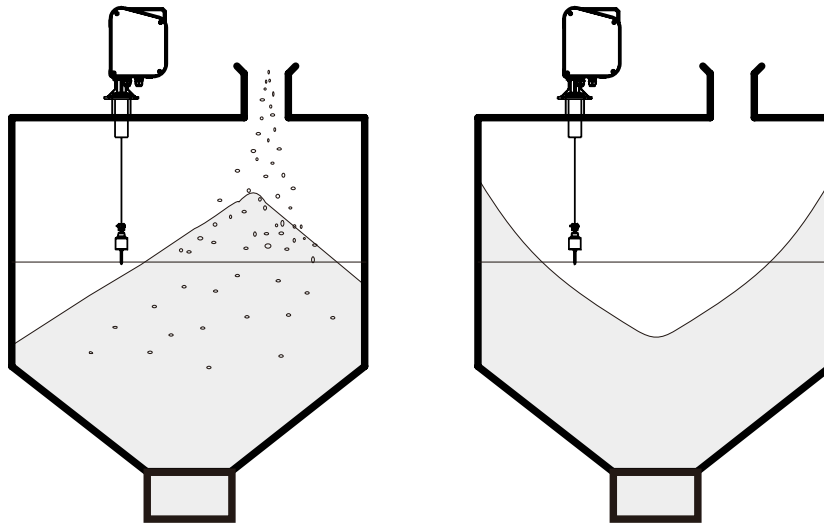

## 6.2. Installation Instruction

6.2.1. During installation, the flange should be mounted at horizontal. Besides, the housing and cable wire should be kept in vertical direction related to the measured material level. It should be carefully checked that the flange can let the wire cable move free and doesn't rub against the body.

6.2.2. On demand, user may connect an extending tube to connect the flange. If you do that, keep it in mind that minimum diameter should not be less than 4".

6.2.3. For leakage, FineTek suggests customer should use O-ring seal or washer between the flange connections and secure it if indeed.

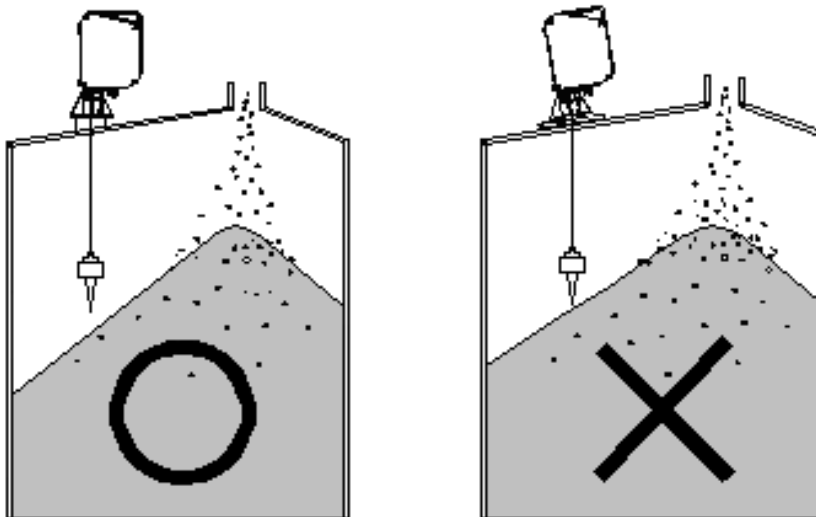

## 6.3. Caution

6.3.1. During installation, user should carefully check that the cable wire is wound up well in pulley set and no kinks, broken, or any abnormal compress on the cable wire.

6.3.2. The cable wire should be put on the hole of the weight head connector and be secured tightly by screwdriver.

6.3.3. Firmly secure the screws to fix the front cover and body, otherwise the dust or powder will pour into the electric board.

6.3.4. The opening portion for the weight head and cable wire must be larger than 104 mm.

6.3.5. Please do not modify the length of steel wire, it may cause malfunction of spool.

## 6.4. Wiring Instruction



### 6.4.1. System Diagram

※ Below image is only an example, order will be included sensor only.

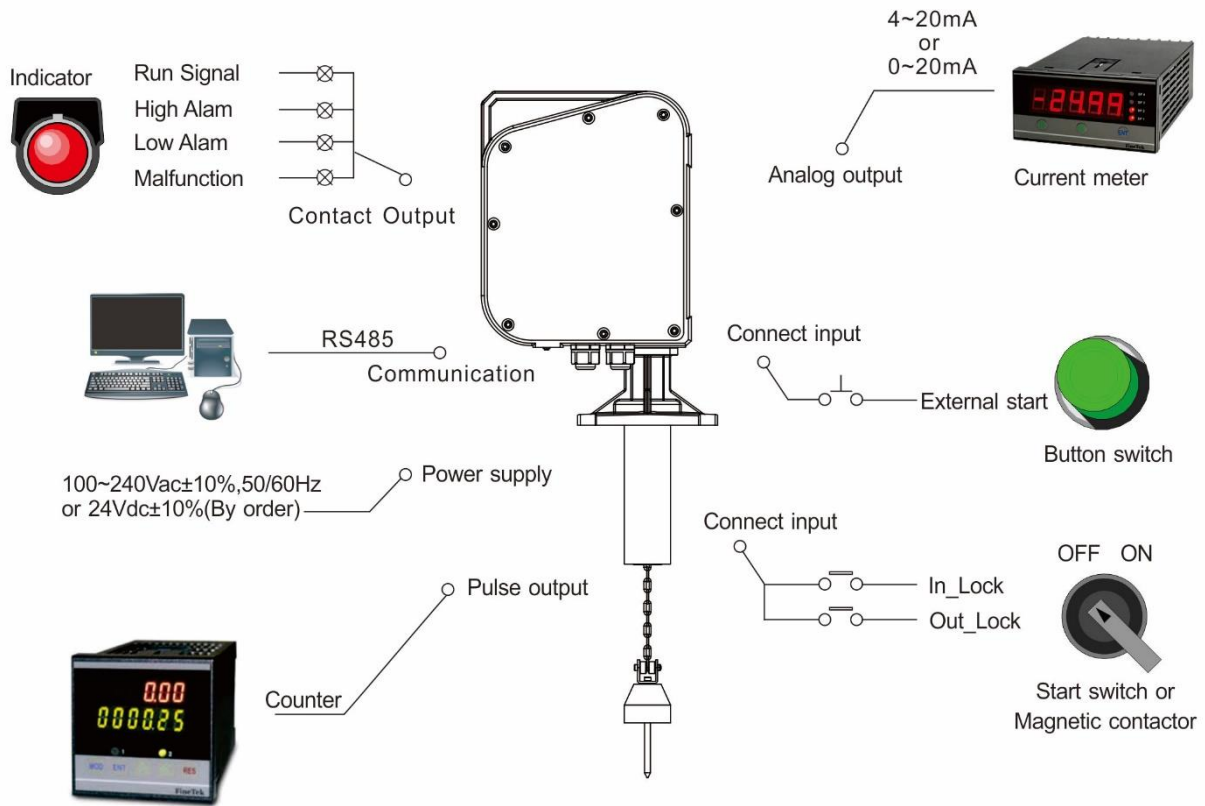

#### Warning:

In order to avoid the sensing weight to be buried or impacted by the material and cause the damage on the equipment, please install material fill-up protection. It is recommended to connect with the conveyor control switch or the “NO” contact input of the contactor. If there is a concern that the sensing weight will be caught by the conveyor and cause damage to the equipment, It is recommended to install the material outlet protection and connect it in parallel with the fill-up protection



6.4.2. FineTek suggests 0.75mm<sup>2</sup> non-twist multiple-cores isolated electric wire to connect with the terminal block. The power line should be separated from the signal lines. It is recommended to leave a flexible length of electric wire to avoid pull and drag by the electric board.

6.4.3. Strip the electric wire to the appropriate length – do not leave unnecessary bare wire exposed.



6.4.4. All bare wires should be soldered and secured well to the terminal block.



6.4.5. Wiring label should be clearly identified and wired correctly. The wiring diagram is below.

### AC type

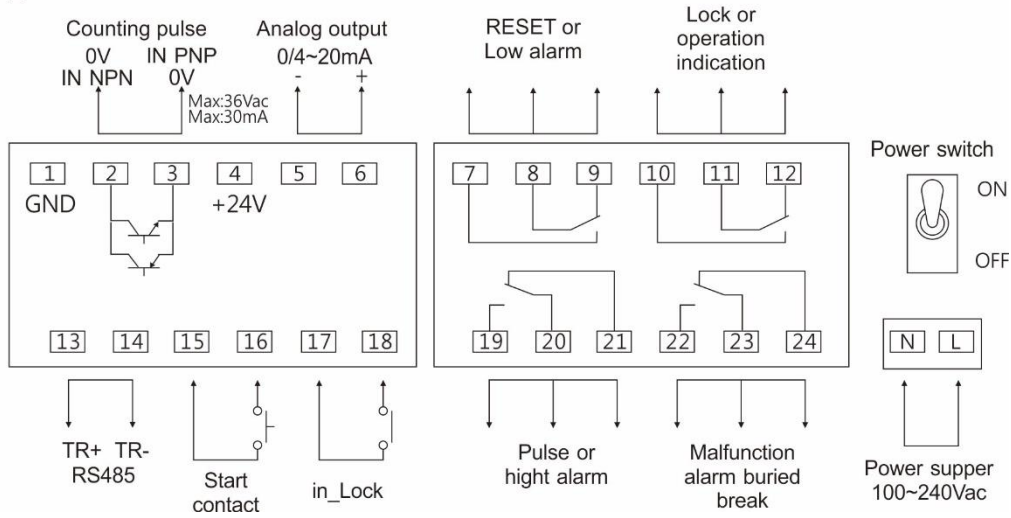

### DC type

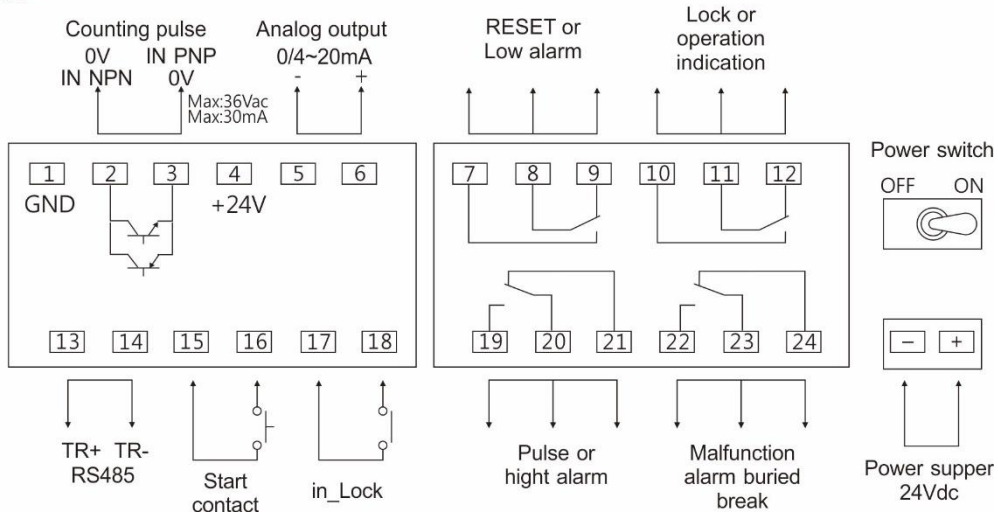

### 6.4.6. Connect Assignments



Terminal number	Description
2.3.	Transistor Output (Pulse) NPN/PNP
5.6.	Analog Output 0/4-20mA(AGND.AOUT)
19.20.21.	Relay 1 : Pulse or High Alarm (NO1 、 COM1 、 NC1)
7.8.9.	Relay 2 : Reset or Low Alarm (NO2 、 COM2 、 NC2)
22.23.24.	Relay 3 : Malfunction alarm ...(NO3 、 COM3 、 NC3)
10.11.12.	Relay 4 : Operation indication or Lock (NO4 、 COM4 、 NC4)
13.14.	RS485 (TR+ 、 TR-)
15.16.	Start Connect (RUN 、 GND)
17.18.	Material fill-up protection switch input (dry contact)

# 7. Operation

## 7.1. Panel

### AC type

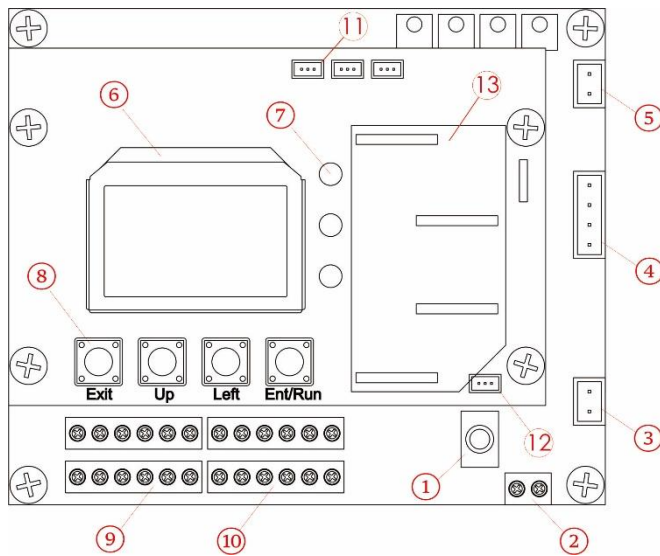

### DC type

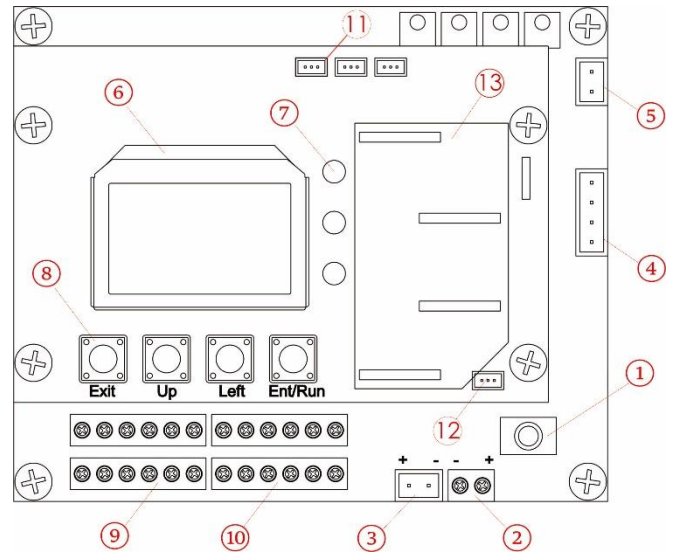

- ① Power switch: On-site operation, maintenance, and power off when needed.
- ② Power terminal: power input 100~240Vac, 50/60Hz or 24Vdc (please confirm the order specification)
- ③ Heater terminal: connected to the internal antifreeze heater.
- ④ Power system terminal: connect with DC power supply.
- ⑤ Motor Power terminal: connect to the motor DC24V
- ⑥ Display: status display, height indication, fault indication, parameter setting
- ⑦ Indicator light:
  - (Green) → Power indicator: Lights up when power is on, and the light is turned off when the power is disconnected.
  - (Yellow) → Operation indicator: Lights up during the measurement (up and down), and lights off when measurement ends.
  - (Red) → Fault indication: Lights up on wire breakage, buried, knot, over-heat occurs, and lights off when troubleshooting is finished.
- ⑧ Button:
  - Ent/Run: Measured value display mode = start the measuring.  
Menu mode = enter into the next menu / confirm to save.
  - Left: Measured value display mode = enter into the menu.  
Menu mode = scroll down the menu.  
Number mode = cursor moves to left.
  - Up: The number on the cursor increases.
  - Exit: Return to the previous menu.
- ⑨ Input/output terminal: Transistor pulse output/external trigger/fill-in protection.
- ⑩ Relay output terminal: Relay 1~4.
- ⑪ Connector socket: wiring with Sensor connector
- ⑫ Connector socket: wiring with Sensor connector
- ⑬ Connector socket: wiring with the wireless module (if any) connector

## 7.2. Operation flowchart

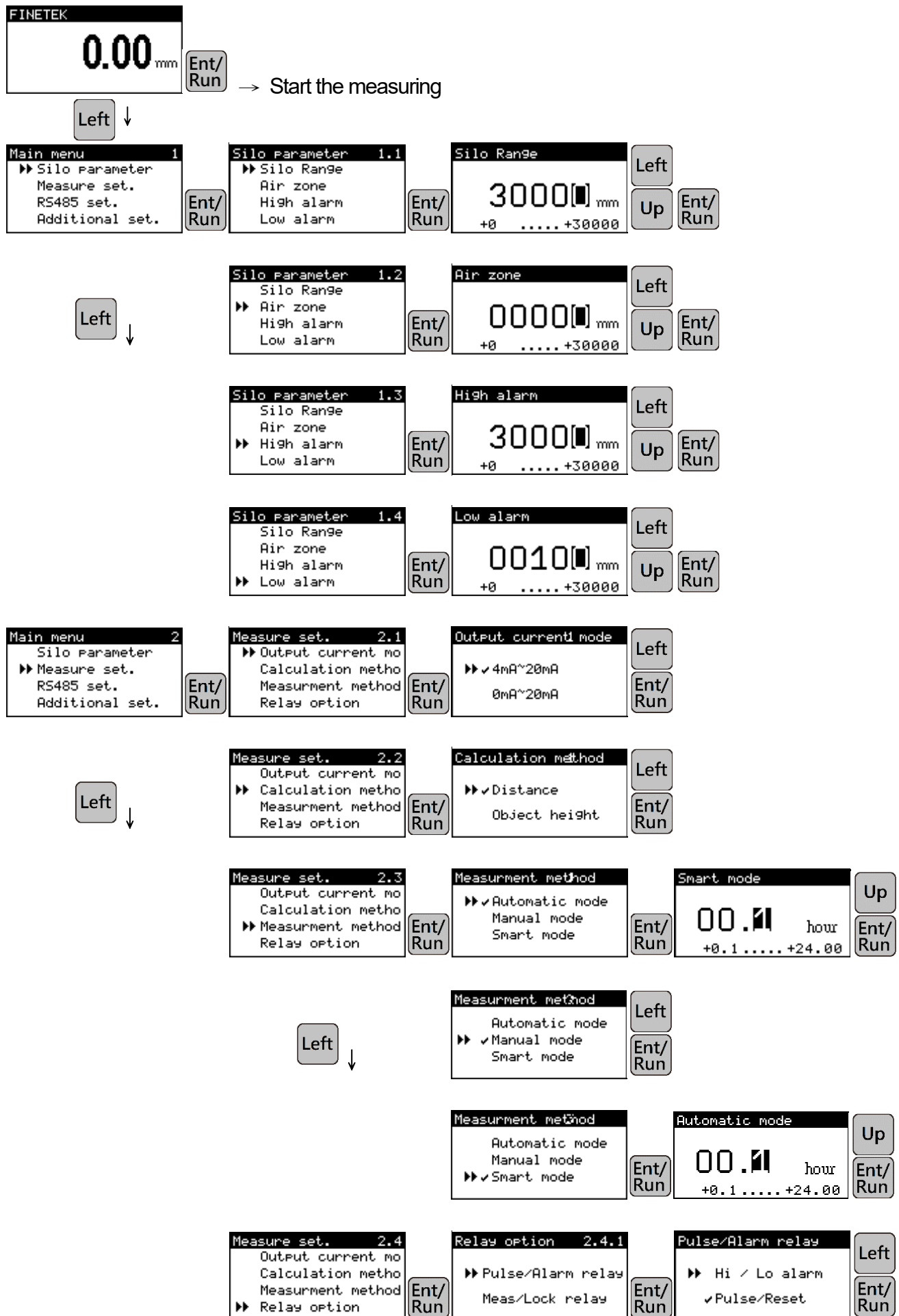



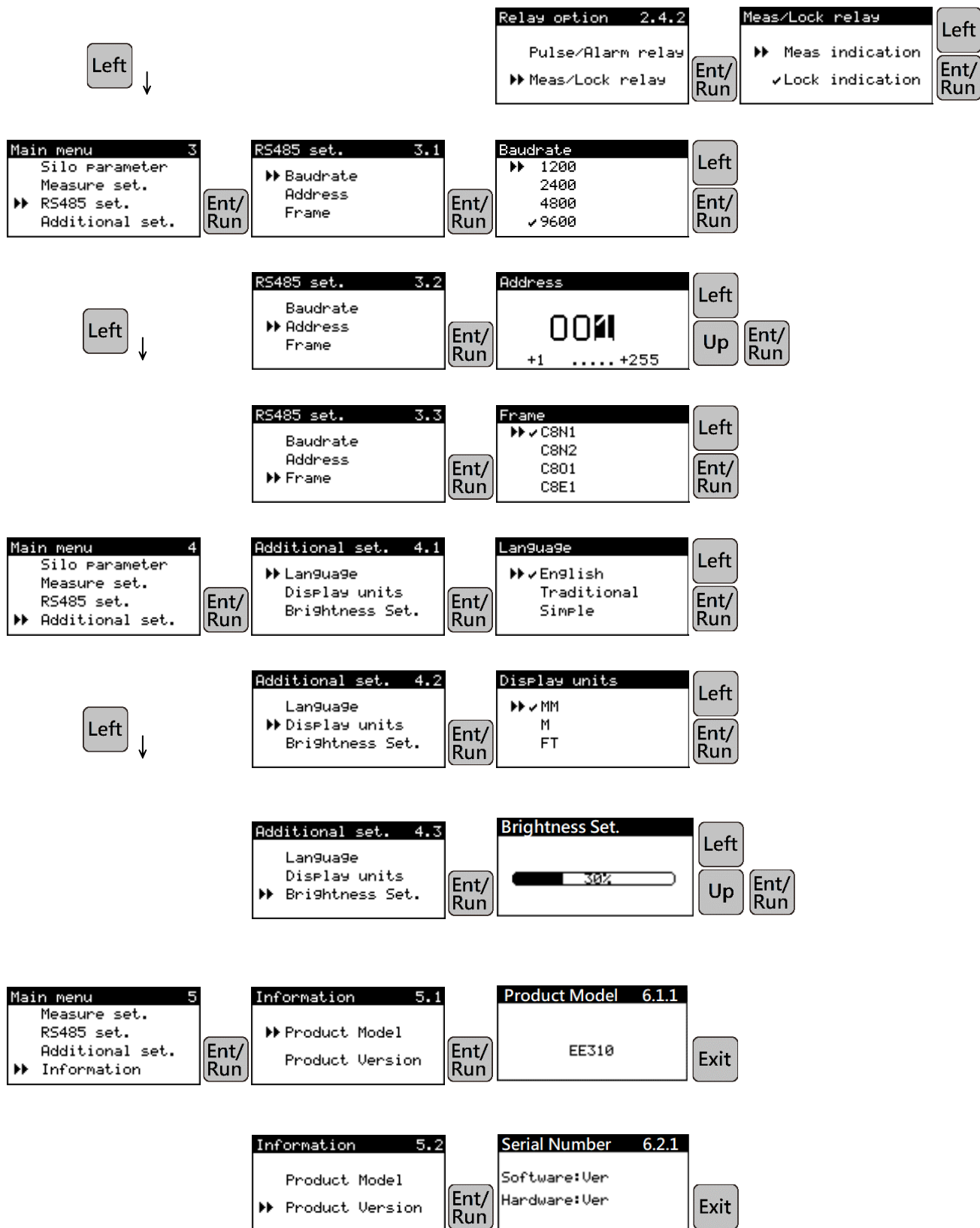

### 7.3. Communication

Address(Dec)	Data Type	Unit	Range	Definition	Authority
4103	FLOAT32			Measured value : Distance / Material height (cm)	Read
4104	FLOAT32	0.01ft	0~20	Current Output	Read
4109					
4110	UINT16	0.01ft	1~254	modbus ID / Address	Read
4130					
4131	UINT16	0.01ft	0~6	Baudrate : 0:1200 · 1:2400 · 2:4800 · 3:9600 · 4:19200 · 5:38400 · 6:57600	Read
4132	UINT16	0.01ft	0~3	modbus frame : 0:C8N1 · 1:C8N2 · 2:C8O1 · 3:C8E1	Read
4133	UINT16	0.01ft	0~2	Error code : 0:Normal · 1:Buried · 2:Break · 4:Knot · 8:Lock · 16:Over current · 32:Over temprature · 64:High alarm · 128:Low alarm · 256:Over tank height · 512:Home sensor abort	Read
4134	UINT16	0.01ft	0~2	Motor operation direction : 0:Stop · 1:Clockwise(CW) · 2:Counterclockwise(CCW)	Read
4136	UINT16	0.01ft	0/1	Output current mode : 0:4~20mA · 1:0~20mA	
4137	UINT16	0.01ft	0/1	Calculation method : 0:Distance · 1:Material height	Read / Write
4138	UINT16		0~2	Measurement methods : 0:Automatic · 1:Manual · 2:Smart	Read / Write
4139	UINT16		1~240	Automatic mode timing	Read / Write
4140	UINT16		1~240	Smart mode timing	Read / Write
4141	UINT16	minute	0~3000	Silo parameter : Silo range (mm)	Read / Write
4142	UINT16	minute	0~3000	Silo parameter : Blind spot (mm)	Read / Write
4143	UINT16		0~3000	Hi alarm (mm)	Read / Write
4144	UINT16		0~3000	Lo alarm (mm)	Read / Write
4145	UINT16		0/1	External start : 0:No start · 1:Start up	Read / Write
4147	FLOAT32	mm	0~9843	Measured value : Distance / Material height (ft)	Read
4148					
4149	FLOAT32	mm	0~9843	Silo parameter : Silo range (ft)	Read / Write
4150					
4151	FLOAT32	mm	0~9843	Silo parameter : Blind zone (ft)	Read / Write
4152					
4153	FLOAT32	mm	0~9843	Hi alarm (ft)	Read / Write
4154					
4155	FLOAT32	mm	0~9843	Lo alarm (ft)	Read / Write
4156					
4204	FLOAT32		0~30000	Measured value : Distance / Material height (mm)	Read
4205					

4206	FLOAT32		0~30000	Silo parameter : Silo range (mm)	Read / Write
4207					
4208	FLOAT32	mA	0~30000	Silo parameter : Blind zone (mm)	Read / Write
4209					
4210	FLOAT32	mm	0~30000	Hi alarm (mm)	Read / Write
4211					
4212	FLOAT32	mm	0~30000	Lo alarm (mm)	Read / Write
4213					
4217	UINT16		0/1	PULSE/Hi RELAY set up : 0:pulse output · 1: hi alarm RESET/Lo RELAY set up : 0:pulse reset · 1:lo alarm	Read / Write
4218	UINT16		0~2	Display unit : 0:mm · 1:m · 2:ft	Read / Write
4219	UINT16		0~2	Language : 0:English · 1:Traditional Chinese · 2:Simplified Chinese	Read / Write
4220	UINT16		0/1	LOCK_ALARM RELAY set up : 0:Measurement instruction · 1:Loading protect instruction	Read / Write
4247	UINT16		0/8013	Restart : 0: No action · 8013:Restart	Read / Write
4248	UINT16		0/1	Parameter storage : 0:No action · 1:Storage	Read / Write
4250	UINT16		0/1	Restore preset parameters : 0:No action · 1:Restore preset parameters	Read / Write

## 7.4. Setting Procedure



**Caution:** When the reservoir or storage is empty, or the detected level is unknown, please don't start the EEX. Start EEX only when you have basic information about the reservoir or storage.

Always avoid having the weight head getting stuck by the conveyer or stirred by any mechanism near the inlet or outlet.

Before setting, user should note that the measuring level should not access the bottom of the reservoir or storage. Do not install EEX next to any obstacle around.

## 7.5. Definition

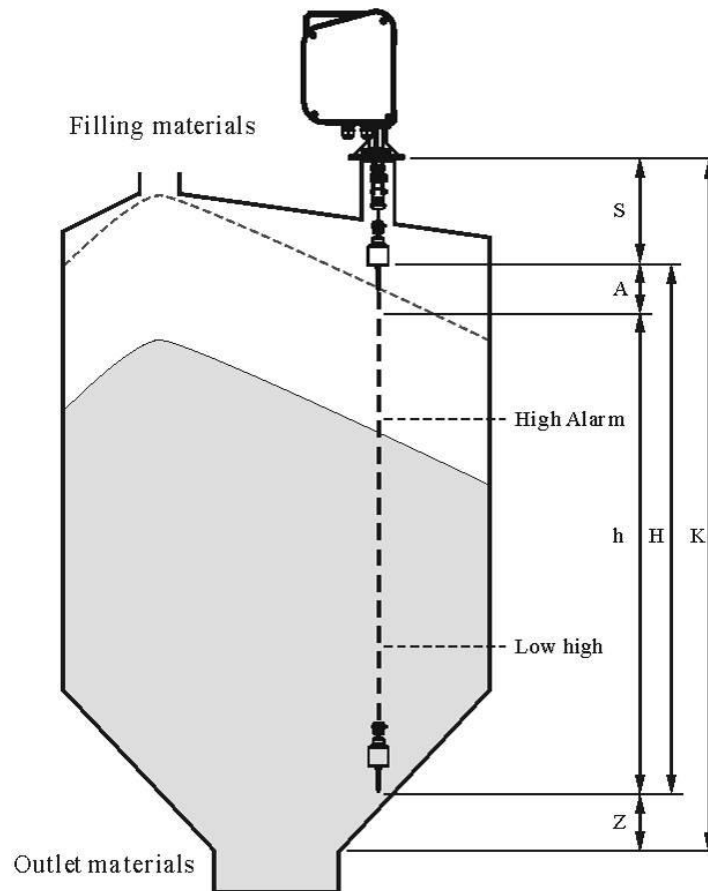

- K→Tank Height : distance between connecting flange to tank outlet
- S→Blind Distance : distance from connecting flange to the tip of the weight
- Z→Safety Distance : To avoid obstacles and prevent weight sliding into the outlet.
- H→Measuring Height : Full measuring range from drop and return with full pulse signal record (Menu: 1.1 Silo range).
- A→Air Zone(deadband) : Variation of tank capacity and real medium level. Default setting is 0 (Menu: 1.2 Air zone).
- h→Effective measuring distance : distance will change according to A value and corresponds to 0/4~20mA output signal.
- Hi Alarm : High level alarm setup (Menu: 1.3 High alarm).
- Lo Alarm : Low level alarm setup (Menu: 1.4 Low alarm).

**7.6. Description of Smart Mode**

Smart mode operates the measurement according to the capacity and level of reservoir. In smart mode, the next measuring time period is depend on the current level distance measured. It is roughly a step by step (0.1 hour for each step), in quasi-linear relation, as indicated below. (Note: Timer value should be larger than Smart value).

**Example:**

Timer=1.1h 、 Smart=0.1h 、 H=10m

Measuring time at next,  $t=(Smart+(A/H) \times (Timer-Smart))$

Where the Timer is the maximum standby time to detect, Smart is the minimum standby time to detect. A is the measuring level distance, H is the High Alarm value. T is the next measuring time since this measurement.

- A is 10m, the next start detect time is  $0.1+1 \times 1=1.1h$
- A is 1m, the next start detect time is  $0.1+0.1 \times 1=0.2h$

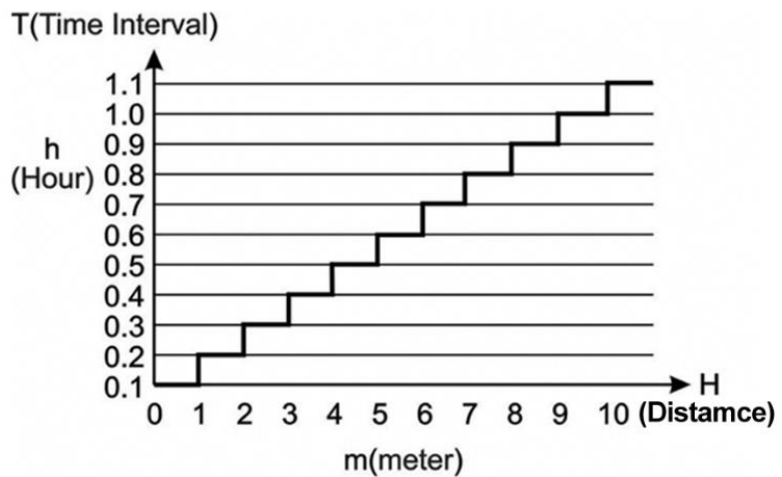
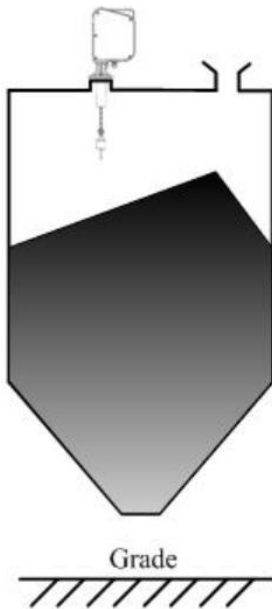

Time Interval And Measuring Range Comparison Table

## 8. Maintenance



### 8.1. Regular Maintenance

8.1.1 Regularly check and secure each part and examine if the screw nut is loose. Every six months open the cover and brush off the dust collected to avoid clogged up electric board.

8.1.2 Inspect the cable wire for any kinks, knots, fatigue, or breakage. Replace the cable wire according to EE310 original specification if necessary.

### 8.2. Cable Wire Replacement

8.2.1 Cut the appropriate cable wire length  $\Phi 1.2\text{mm}$  (total measuring length+500mm), and insert the cable wire through the steel pipe  $\Phi 4.0 \times 0.5\text{mm}$ . There are two holes on the side board of the receiving pulley, insert the cable wire through one hole first and then guide the cable wire to the other hole & go back through the steel pipe. Use the pliers ( $2.0\text{mm}^2$  for holes) to do the crimping firmly at the central end of the steel pipe (Fig.1).

8.2.2 Insert the end of the cable wire through in order from the measuring pulley, sliding rod, dustproof brush, dust wiper, dustproof mechanism base (note that the sequence path cannot be misplaced, refer to Fig. 2). Straighten out the cable wire and eliminate bending or entanglement to ensure it could rewind smoothly, and if it stands on high location, please drop the cable wire freely at a safe area.

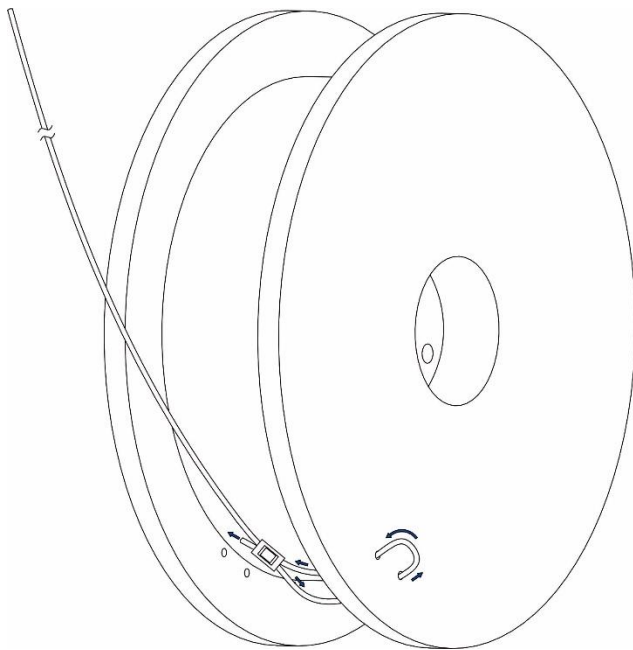

Fig.1

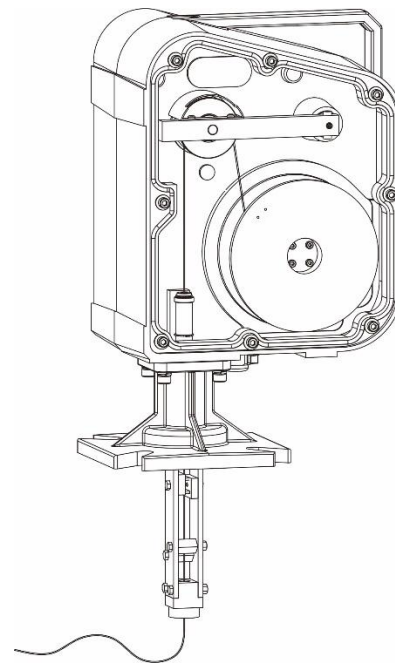

Fig.2

8.2.3 Put on the gloves on one hand and slightly drag the cable wire to avoid being too loose when it winds up. Operate the power ON/OFF by the other hand to control the receiving pulley to wind up the cable wire smoothly. Put the cable wire in the tray smoothly, and leave a short section (0.5~1m) in front of the dustproof mechanism base in order for weight installation (Fig.2).

8.2.4 Insert the end of the cable wire through the hanging bolt of the sensing weight and the short steel pipe which is used for crimping, and then go through the steel pipe again in a circle. Use the pliers (2 mm<sup>2</sup> for holes) to do the crimping firmly at the central steel pipe (Fig.3).

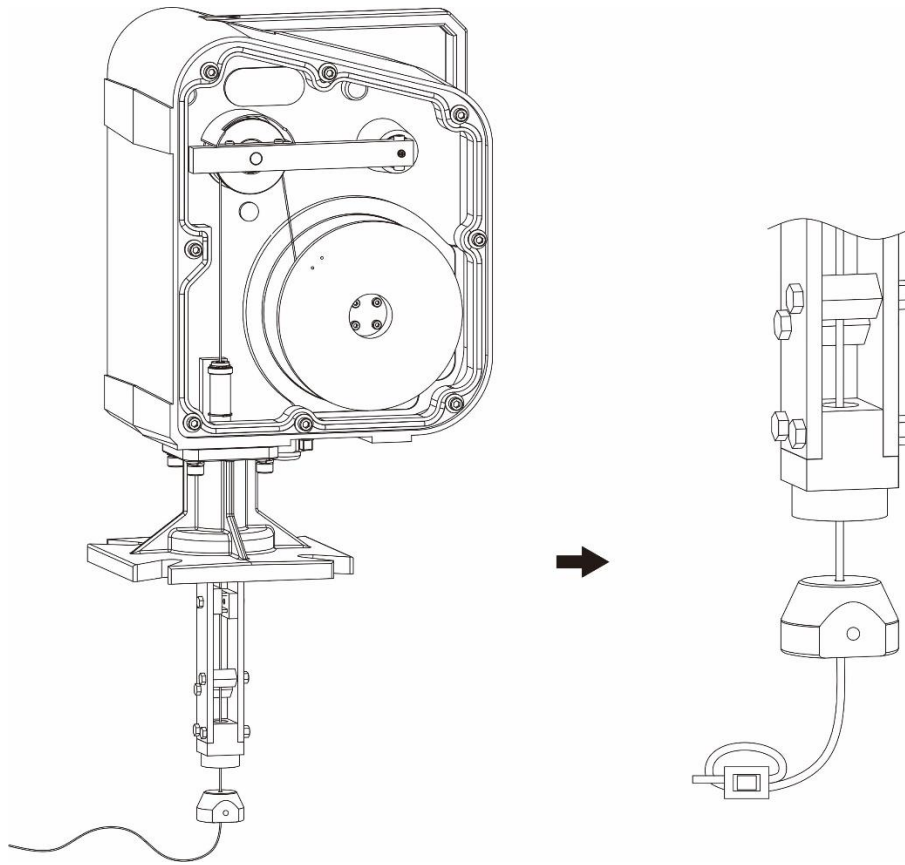

Fig.3

### 8.3 Sensing weight replacement

8.3.1 Put the U-shaped lifting ring on the top of the sensing weight, fix the equal-height screws and use the hexagonal wrench to tighten it. Put the M4 screw to go through in order from lifting ring, locating ring, iron chain, locating ring, lifting ring, and fix the arresting nut and tighten it firmly (Fig.4 & Fig.5).

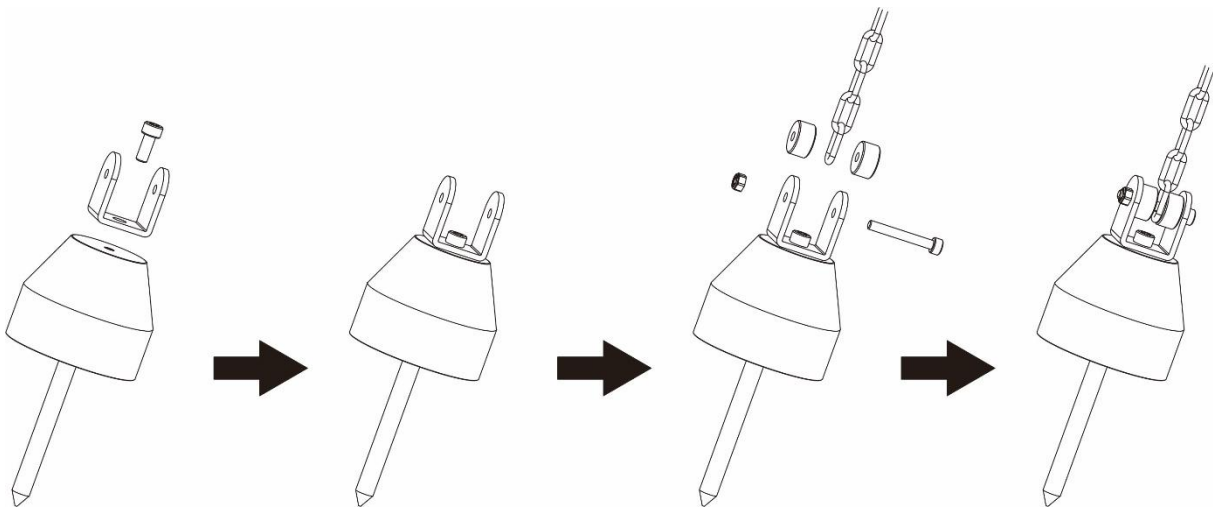

Fig.4

8.3.2 The operation of the U-shaped ring of the plastic Auto-Fall-Off sensing weight same as 8.3.1. The plastic sensing weight must be filled with the material at 0.9~1.0kg before use. When connecting, the head of the plastic weight is aligned with the socket and inserted to the end completely, try to pull the sensing weight to confirm that the installation is correct (Fig 6)

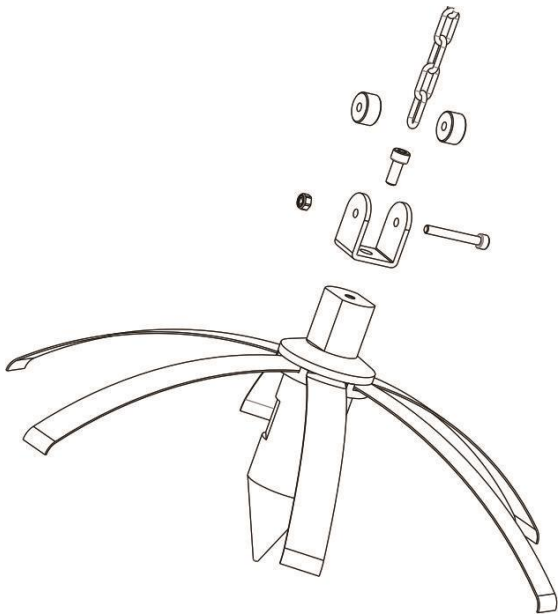

Fig.5

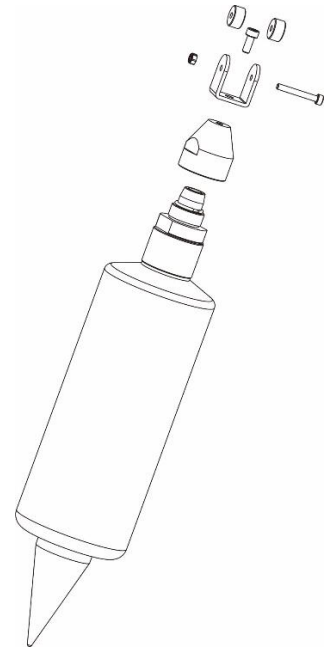

Fig.6

8.3.3 Pull the cable wire to fully retract the crimped steel pipe into the top of the hanging bolt, put the end of the iron chain to go through the hanging bolt of the sensing weight, Put the M4 screw to go through the hanging bolt, iron chain, and fix the arresting nut and tighten it firmly (Fig.7).

8.3.4 After finishing the above installation, turn on the power and the motor will rotate to collect the remaining cable wire into the receiving pulley (Fig.8).

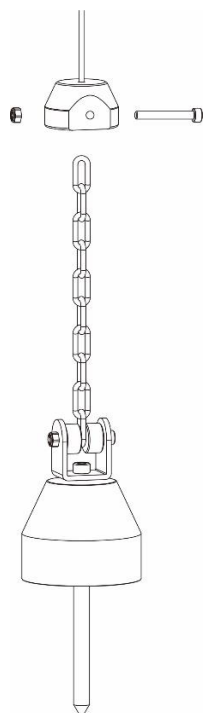

Fig.7

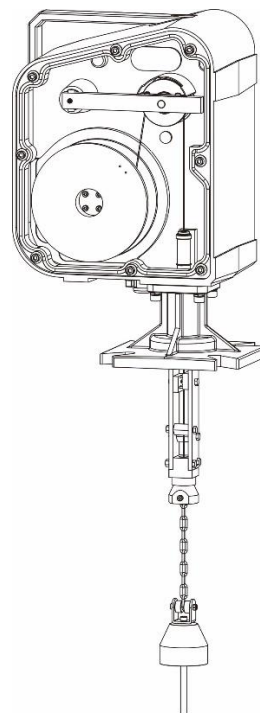
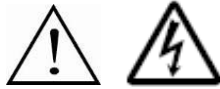

Fig.8



## 9. Troubleshooting



Issue	Possible Reason	Examination	Solution
No display (black screen) Indicators don't light	Screen saver program is executed	Push one of three buttons "ENT", "LEFT", "UP" to act the display	Push "ENT", "LEFT", "UP" to act and make LCM bright Push "RUN" to start the measurement
	No power input or no power on switch	Power switch status and power line connector	Turn on power
	Wire broken	Check the voltage at power input	Replace wire or provide correct power
	Construction mistake or circuit short	Check fuse on electric board	Replace fuse
	Power supply failure	Check the voltage of secondary power supply is 24 VDC	Replace power supply module or contact FineTek
With display but not execute detection	External trigger wire broken (15, 16)	Check if RUN command can act or not	Repair wire at terminal 15,16
	Motor wire broken	Check the wire condition with motor	Replace motor wire or contact FineTek
	High pressure in reservoir or storage, made the weight head can't droop down	Observe if gas or dust eject from EEX	Check the cover secure and fix the screw, or contact FineTek
	Dust inside the housing, blocking and affect the movement of sliding rod.	Checking the housing for dust and sliding rod.	Cleaning the housing and remove dust, forbid to use any lubrication oil.
	Firmware failure	Restart it and get it normal, but it will fail randomly.	Contact FineTek
Host is uncontrolled, continually releasing or receiving wire	Short circuit happened in terminal 15 & 16	Check terminal 15 & 16 for resistance value	Check wiring and remove short circuit
	It was influenced by other induced voltage nearby.	Check every wire for if any unstable voltage.	Use shielded cable and make sure it grounded well
Sensing weight only going down 20~25cm and back to standby	Magnet on sliding rod got off, can't sense position and system forces it to come back	Check magnet on top of sliding rod is completed or not	Contact FineTek
Measurement result is quite different from actual result	There are damages in wire, inadvertently touch the switch as in measurement	Check whole wire if any obvious damage	Replace with new wire
	Impacted by filling materials as in measurement	If material filling protection function is connected	Start the protection function and avoid measurement as filling materials

Indicator Message: Broken	Cable Wire Broken	Check the cable wire	Replace cable wire and weight head
	Cable wire derail the hub of pulley	Check the pulley and cable wire	Reassembly cable wire and pulley follow instruction at section 8.2 & 8.3
	Low Alarm circuit close	Cable wire & weight head, pulley are in normal	Contact FineTek
Indicator Message: Buried	Weight Head was buried	Check if the weight head was buried by observation window or dismounting the flange	Stop fill in materials and wait the restart automatically
	Magnet on sliding rod got off, can't sense receiving position and keep receiving with no stop.	Check magnet on top of sliding rod is completed or not	Contact FineTek
	Relay switch for buried is malfunctioned	Steel wire and weight are normal in good condition.	Contact FineTek if same problem after reboot.
	Materials stuck on weight, too heavy to cause wrong signal.	Check the weight if it becomes too heavy.	Remove all the materials attached on weight and wire.
Indicator Message: KNOT	Cable stuck on the receiving pulley, can't work normally	Cable winded and stuck on the receiving pulley	Disassembling the receiving pulley and release the wire, power on again and the cable will be received
	The flexstrip cable is not connected.	The flexstrip cable was pulled out and not connected	Plug in the flexstrip cable and turn off the power. Restart the EEX
	The motor cable is not connected.	The motor cable was pulled out and not connected	Plug in the flexstrip cable and turn off the power. Restart the EEX
Indicator Message: Broken & Buried	The flexstrip cable is not connected well or components damaged.	Check and plug in the flexstrip cable well and reboot to back to normal	Contact FineTek if same problem after reboot.
Indicator Message: Broken & Buried	Alarm output wiring is disconnected	Check if the wiring line with abnormal	Repair wiring path
	Measuring level height and alarm settings have been changed beyond the normal range	Check the parameter settings, high and low alarm settings fall in the blind zone or exceed the measuring height	Correct the parameter settings, measure the height, blind zone high and low alarm settings