

AHUJA®

PA AMPLIFIER
2500W RMS

OPERATION MANUAL

SPA-25000

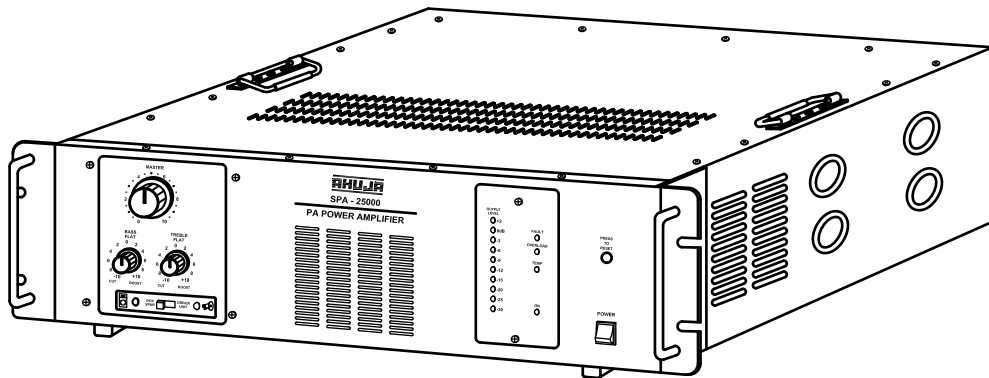

- Thank you for purchasing the AHUJA PA Amplifier.
- Please read this manual thoroughly before making connections and turning on the power. Following the instructions in this manual will enable you to obtain optimum performance from your new AHUJA PA Amplifier.
- Please retain this manual for future reference.

• Safety Instructions

Read the Instructions: Please read all the instructions in this section carefully before installation or use of the product. All the safety instructions must be followed.

Retain the Instructions: Please retain this Instruction Manual for future reference.



This symbol, wherever it appears, alerts you to the presence of uninsulated hazardous voltage that may be sufficient to constitute a risk of electric shock. External wiring to any terminal marked with this symbol must be done by a trained and instructed person only.



This symbol, wherever it appears adjacent to a component, alerts you that the concerned component can only be replaced by another of the exact same specifications.

WARNING

- To reduce the risk of electric shock, do not remove the top cover. No user serviceable parts inside. Refer all servicing to qualified personnel only.
- Before replacing any fuse, make sure the set is switched off and disconnected from the AC mains or any other power source. Replace a fuse only with another of exactly same specification.

CAUTIONS

Water & Moisture: To reduce the risk of fire or electric shock, do not expose this set to rain or moisture. Do not use this set near water or in a wet location. Do not keep any object filled with liquid, such as a vase, on top of this set. Do not insert or remove the AC mains plug with wet hands.

Power Source: The voltage & frequency of the AC mains supply, and the voltage of the external battery, (if applicable) to which this set can be connected, is marked on the rear panel of the set. Do not connect this set to any power source other than those specified on the rear panel.

Power Cord Protection: Do not cut, kink, damage or modify the AC power cord supplied with this set. Keep the AC power cord away from heaters and harmful chemicals. Do not keep any heavy object on the power cord.

Operation on Generator: When operating this set on a generator, make sure the set is switched off till the generator voltage has stabilized.

Ventilation: This set should be situated so that its location or position does not interfere with its proper ventilation. Do not cover the ventilation holes / slots. Do not insert or drop anything into the ventilation holes / slots.

Stability: This set must be kept in a stable and flat horizontal position, and never in a tilted position. Do not place this set on an unstable stand, tripod, bracket or mount. Do not use attachments which are not supplied or explicitly recommended by the manufacturer.

Cover Strip: The cover strip of the 100V / 70V audio output terminal strip, and of any other high voltage output terminal strip, must be replaced after making connections. Failure to do so may result in exposure to hazardous voltages.

Earthing: This set must be earthed properly before use. A wire from the Earth terminal on the rear panel must be connected to electrical earth.

Cleaning: Disconnect this equipment from the AC mains and external battery before cleaning. Clean with a damp cloth, but do not allow any liquid to enter the set. Do not clean with liquids or aerosols.

Exposure to Heat: Do not touch the heatsinks while the set is working.

Contents	Page No.
Features/General Description of Product	4
Front Panel Controls & Features	5
Rear Panel Controls & Features	6
Interconnections	7
Speaker Connection Guidelines	8
Typical Applications	11
Specifications	12

• Features/General Description of Product

- SPA-25000 is a Booster Amplifier with 2500 Watts rated power output. It can accept input signals of nominal level 1V or 200mV. Balanced or Unbalanced input can be used. A selector switch on the rear panel selects between 1V sensitivity and 200mV sensitivity.
- An XLR and a 6.3mm stereo phone jack is provided on the rear panel for balanced inputs. A mono 6.3mm phone jack is provided on the rear panel for unbalanced inputs.
- Also balanced line out through XLR jack and unbalanced line out through phone jack is available on the rear panel.
- SPA-25000 also has 100V input facility. A two pin terminal strip is provided for 100V input signal.
- Box Speaker/ Driver Unit selector switch has been provided for protecting the Driver Units' diaphragm from extra low frequencies. Since Box speakers can reproduce the full spectrum of audio frequencies but Driver Units cannot reproduce very low frequencies, it is recommended that the switch should be towards to the Driver Unit side when Driver Units, Horns or Column speakers are connected.
- Built-in circuit is provided for short circuit protection, thermal protection, overload protection and over voltage protections.
- Circuit Protector Device & DC fuses have been provided. These safeguard the amplifier against overload and short circuit. In case fuse or circuit protector has to be replaced, it must be replaced with another of the same type.
- Ground Lift switch provided on rear panel to eliminate unwanted ground loops, which can some times cause hum.
- Ease of operation, combined with service accessibility has been optimized in the design.

• Front Panel Controls & Features

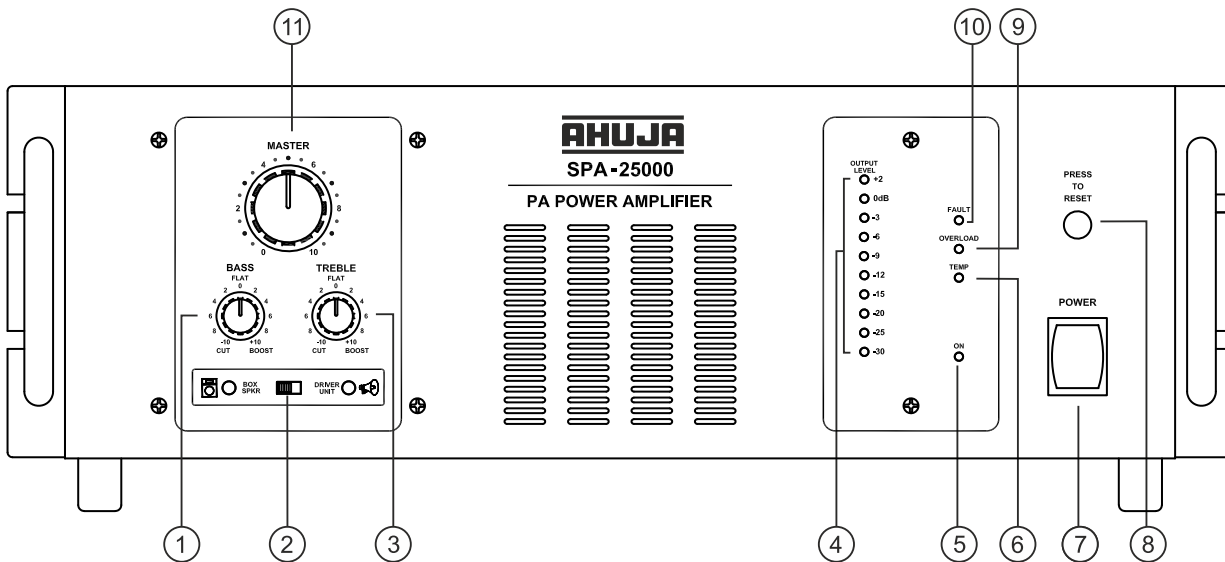

1. **BASS Control**
For attenuating or boosting the signal level of low frequencies.
2. **BOX SPEAKER / DRIVER UNIT Selector Switch**
When kept in DRIVER UNIT position, the “Bass Boost” feature of the Bass control is disabled. This protects driver unit from unwanted low frequencies which they cannot reproduce.
3. **TREBLE Control**
For attenuating or boosting the signal level of high frequencies.
4. **LED Array**
This indicates the output level of the amplifier. Reduce the signal if the RED LEDs are continuously glowing.
5. **POWER LED**
This LED glows when the amplifier is switched ON and indicates that the power supply is ON.
6. **TEMP LED**
The glowing of this yellow LED indicates excessive temperature of the output devices. The protection circuit then mutes the input signals. The amplifier will remain at mute status, till the amplifier cools down to normal temperature.
7. **POWER Switch**
Push the top part of the knob to switch the amplifier ON. Push the bottom part of the knob to switch the amplifier OFF.
8. **RESET Button**
This button pops out when the AC circuit protector trips. Rectify the cause and press the RESET button for resetting normal operation of the amplifier.
9. **OVERLOAD LED**
The glowing of this orange LED indicates that the circuit protector has tripped. The AC mains supply to the amplifier is cut-off till the fault is rectified and the reset button is pressed.
10. **FAULT LED**
The glowing of this red LED indicates that some fault has occurred in the amplifier and either of the DC fuses has blown. The protection circuit then mutes the input signals. The amplifier will remain at mute status till the fault is rectified & blown fuse replaced.
11. **MASTER Volume Control**
For adjustment of the overall volume level from the amplifier.

• Rear Panel Controls & Features

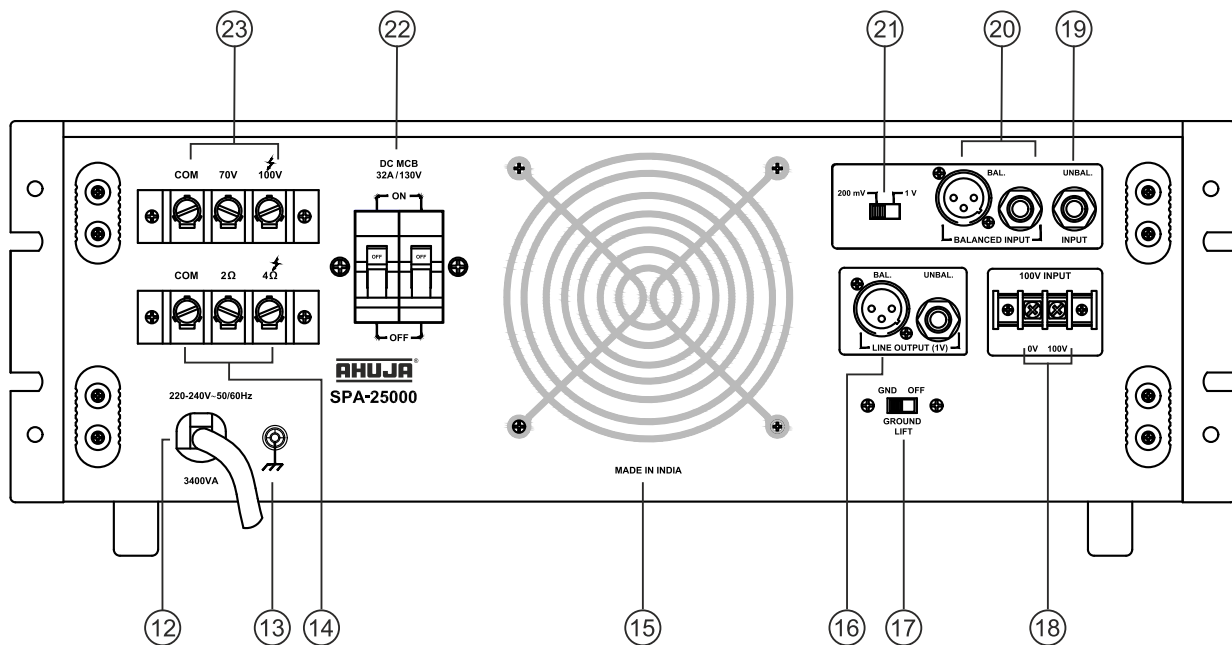

12. 3 CORE AC MAINS CABLE WITH PLUG

13. EARTH Terminal

14. SPEAKER Terminal Block (2 ohm and 4 ohm)

For connecting low impedance speakers.

15. Fan Grill

Protective grill. Do not insert any thing into the opening.

16. Output Jack Socket

For connecting to another booster amplifier to obtain combined higher power output. Phone Jack for Unbalanced Output and XLR connector for Balanced Output.

17. GROUND LIFT SWITCH

This switch helps in reducing the hum content generated due to multiple ground loops while cascading two or more equipments. If any hum is audible, try changing position of this switch.

18. 100V Input Terminal Strip

100V output from any other amplifier can be connected to this amplifier. Input selector switch must be kept at 1V position.

19. Unbalanced Input Jack Socket

For connecting unbalanced input through mono jack.

20. Input Jack Socket

For connecting balanced input either through XLR connector or stereo jack, (connected in parallel). External mixer, CD player etc., can be connected as an input source.

21. Input Sensitivity Selector Switch.

Keep at 200mV when connecting a CD Player or preamp output of another amplifier. Keep at 1V when connecting a mixer or the LINE output of another amplifier.

22. SPEAKER Terminal Block (70V, 100V)

For connecting speakers with 100V line matching transformers.

23. DC Circuit Protector Rating 32 AMP. 220V

These protects the amplifier from any excessive current flow. Keep amplifier to OFF position and disconnect from AC mains while replacing the circuit protectors.

Caution

- The equipment must be earthed properly before operating it to avoid electric shock. A wire from the Earth Terminal must be connected to electrical earth for safe operation.

• Interconnections

- The amplifier can be placed as a tabletop unit. The amplifier should be situated so that its location or position does not interfere with its proper ventilation.
- For AC power supply use an AC earthed mains outlet.
- All connections must only be carried out or changed with the amplifier switched OFF and disconnected from the external power supply.
- To avoid loud switching noise, always switch ON the Power amplifier after all other units of the audio system have been switched ON. After operation, switch it OFF first, then the other units.
- The connection diagram that follows display the typical types of input sources (Keyboard, Cassette Player, Mixer, CD Player etc.) and speakers (Wall, Ceiling, Box, Horn, Column) which can be connected to the amplifier. For correct connections and operation check the specifications of the connected equipment.

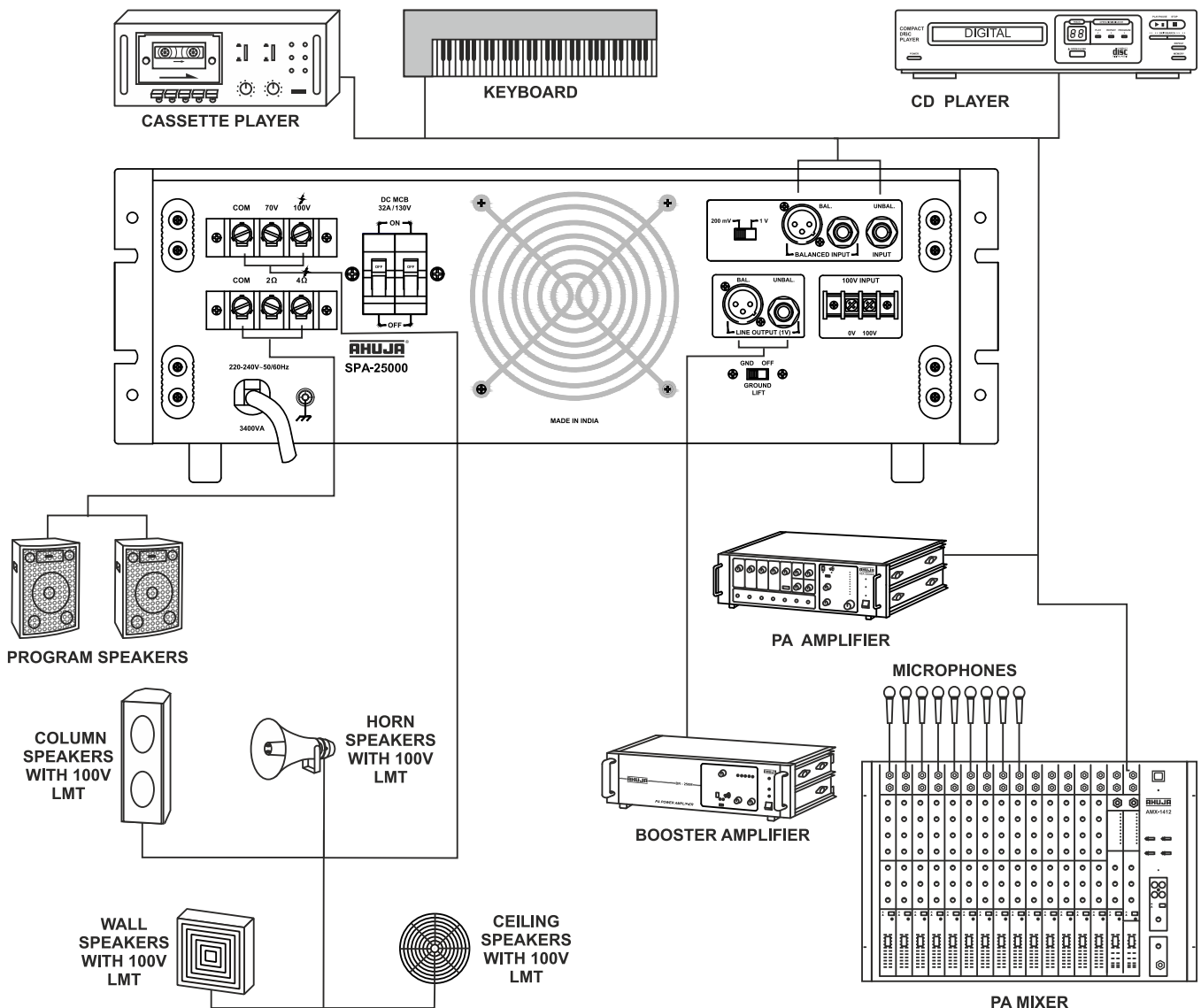

• Speaker Connection Guidelines

SPA-25000 is a very high-powered amplifier. Therefore it is very important that correct loudspeaker connections are made to avoid damage to the amplifier or speakers.

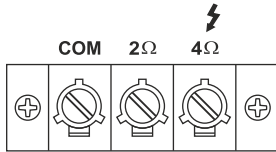

Low Impedance Speaker Connections

Box type Speakers can be directly connected to COM-2Ω or COM-4Ω Terminal Strip.

The Box Speaker / Driver Unit switch should be kept at Box Speaker position.

Connecting Two SWX-1300DX Speakers

The two SWX-1300DX Speakers (each speaker can handle 1300W of power) should be wired in a parallel combination as shown in figure. The resulting impedance will be 2Ω. The speaker system should be connected to the 2Ω tap of the amplifier.

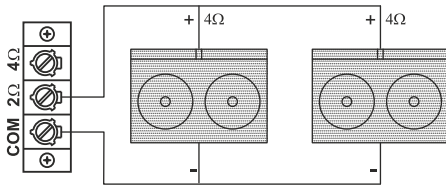

Resultant Impedance = $(4 \text{ Ohm}/2) = 2 \text{ Ohm}$

Connecting Two SPX-1200 Speakers

The two SPX-1200 speakers (each speaker can handle 1000W of power) should be connected in parallel combination as shown in figure. The resulting impedance would be 2Ω. Thus they should be connected to the 2Ω tap of the amplifier.

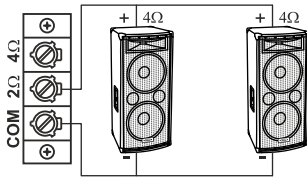

Resultant Impedance = $(4 \text{ Ohm}/2) = 2 \text{ Ohm}$

CAUTION

- When Box speakers are connected to COM-2Ω / 4Ω Terminal Strip NO Speakers / Driver Units with 100V LMTs should be connected to the Red Terminal Strip marked COM-70V/100V.
- Box Speakers should be connected only to either COM-2Ω or COM-4Ω terminals as illustrated above but never to more than one set of terminals.

Speaker Connection Guidelines....

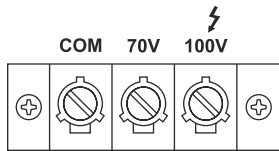

High Impedance Speakers or Speakers Using A 100V Line Matching Transformer

Only Driver Units / Horn Speakers / Column Speakers with 100V Line Matching Transformers are to be connected to COM-70V / 100V Terminal Strip.

The Box Speaker / Driver Unit switch should be kept at Driver Unit position.

The power drawn from the amplifier should not exceed 2500 Watts.

Connecting Eighty Driver Units with 100V LMT

80 Driver Units with 100V Line Matching Transformer connected at 30 Watts tap can be operated.

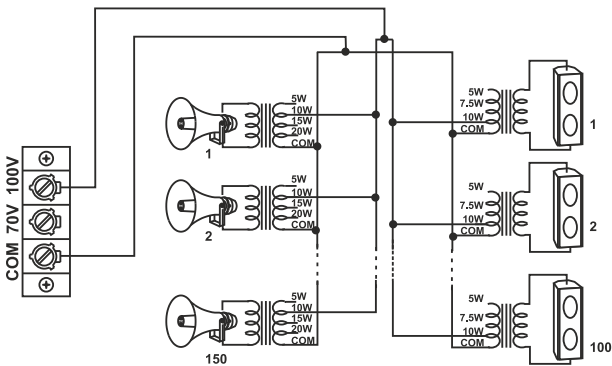
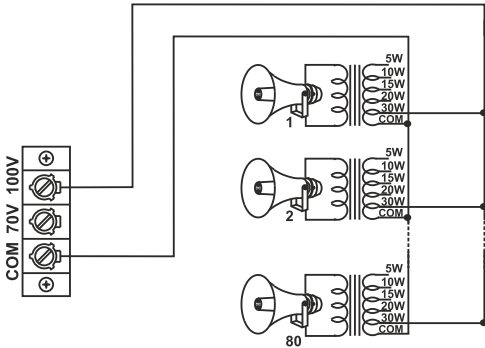

Connecting a Combination of Driver Units and Column Speakers with 100V LMT

150 Driver Units with 100V LMT at 10 Watts and 100 Column Speakers with 100V LMT at 10 Watts can be connected together. The power drawn from the amplifier should not exceed 2500 Watts.

Use of 70 Volt Line

A loudspeaker / Driver Unit with its LMT adjusted to the 40W tap, when connected to COM and 100V terminals on the Amplifier's Terminal Strip will draw 40W from the Amplifier; but when the same is connected to COM and 70V it will only draw half power i.e. 20W. A good use of 70V line tap can be made in installations where large number of Speakers / Driver Units are to be installed for more even distribution of sound.

CAUTION

- When Box speakers are connected to COM-2Ω / 4Ω Terminal Strip NO Speakers / Driver Units with 100V LMTs should be connected to the Red Terminal Strip marked COM-70V/100V.
- Box Speakers should be connected only to either COM-2Ω or COM-4Ω terminals as illustrated above but never to more than one set of terminals.

Speaker Connection Guidelines....

Use of 100V Input

When the distance from amplifier to some speakers is very long, another amplifier may be required mid-way. Then 100V output of 1st amplifier will be taken and fed to 100V input of 2nd amplifier as illustrated below. Input selector switch must be kept at 1V position.

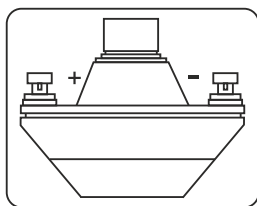
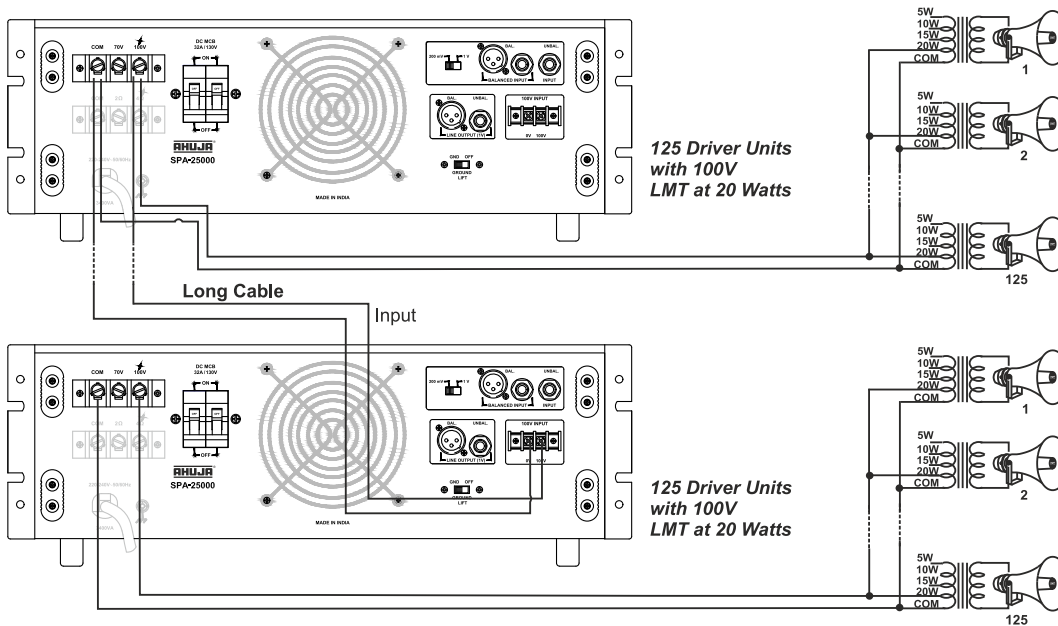

Correct Phasing of Loudspeakers

- When two or more Speakers / Units are installed in the same area and are facing the same direction, it is essential that their cones / diaphragms act in unison. Otherwise the sound level of one speaker will be cancelling the sound level of the other. To avoid any mistake, the terminals of Box speakers and the Driver Units are marked '+' & '-'. Always connect the COM of the Amplifier to '-' of speaker & 2Ω/4Ω of the amplifier to the '+' of the speakers.
- In case of LMT's the COM of all the LMT's should be connected to the COM of the red stripterminal of the amplifier and the power tap to 100V line as shown in figure.

IMPORTANT

- When 70 / 100 Volt line is being used, no speakers / driver units should be connected to 2Ω / 4Ω (Low Impedance) Terminal Strip.
- 100V/70V Loudspeakers / driver units should be connected to either COM-100V or COM-70V terminals, but never to more than one set of terminals.

Connecting One SPA-25000 to another SPA-25000 For Making A 5000W Mono System

1. Connect Microphones and other Program Sources to the input jacks of the Pre Amplifier mixer.
2. Connect the Line-Out of the mixer to the input socket of the first SPA-25000 (BOOSTER A) using a suitable patch-cord. The sensitivity switch next to the input & output jacks should be towards 1V.
3. The line output jack of BOOSTER A should be connected to the input socket of the second SPA-25000 (BOOSTER B). The sensitivity switch of the second booster should also be at 1V.
4. In this manner the inputs connected to the mixer will feed both the amplifiers creating a 5000W output system.
5. Loudspeaker connections to both the amplifiers should be done independently. Each of the amplifiers can be connected to either Box type speakers or to speakers using the 100V LMT but NEVER both together. Speaker system impedance should be matched to the output impedance of the amplifier and thus should be connected to the corresponding tap of the amplifier.
6. When connecting box speakers to an amplifier the Box Speaker / Driver Unit switch should be set to the Box Speaker side and when connecting driver units, wall, ceiling or column speakers with 100V LMT, the switch should be turned to the Driver Unit side.
7. When speakers with 100V LMT are used, total load on any one SPA-25000 should not exceed 2500 Watts.
8. Operate the GROUND LIFT switch on the rear plate of any one SPA-25000, and set to whichever position gives least noise.
9. Finally when operating the system, any adjustments in the tonal quality of the sound, if required, can be made from each of the amplifiers independently.

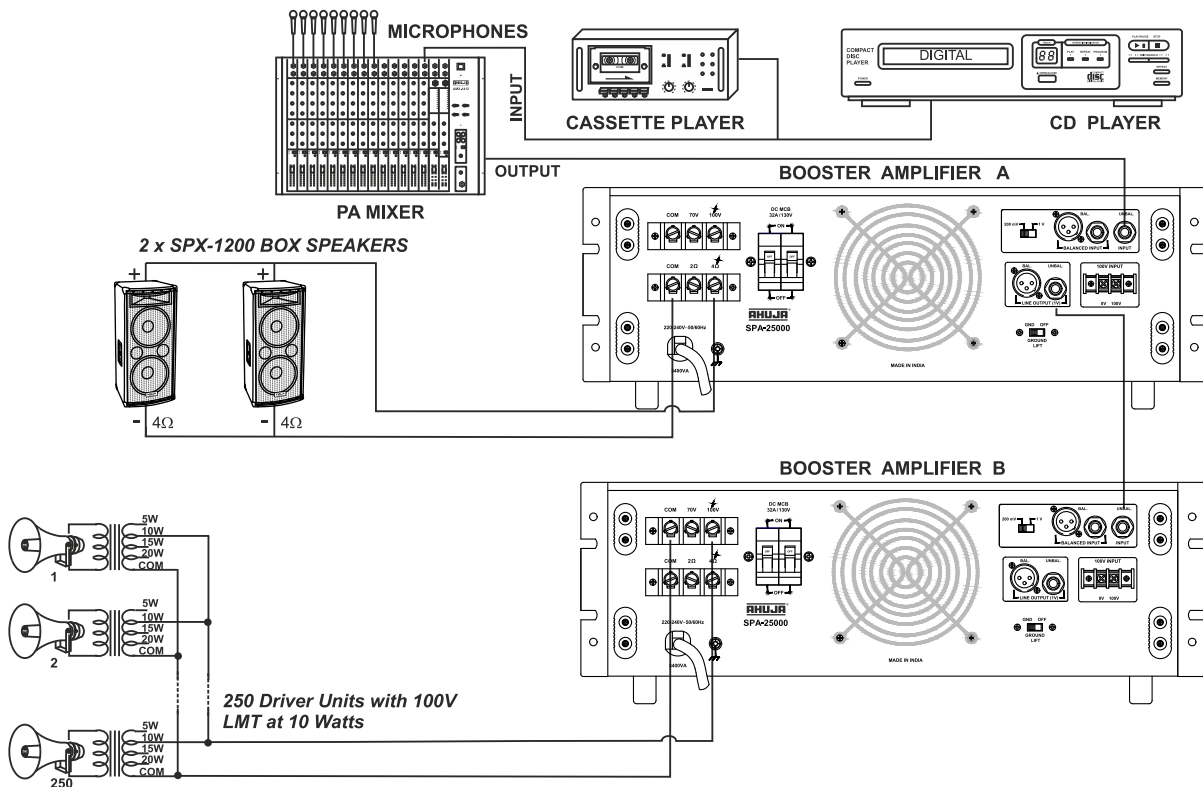

• Specifications

Model	SPA-25000
Power Output	3000W Max. 2500W RMS at 10%THD (Rated) 2300W RMS at 5% THD 2150W RMS at 2% THD
Output Regulation	≤ 2 dB no load to full load at 1kHz
Input Channels	a) 200mV / 20kΩ Balanced / 10kΩ Unbalanced b) 1V / 20kΩ Balanced / 10kΩ Unbalanced c) 100V / 100kΩ
Frequency Response	50 – 15000Hz ±3dB
S/N Ratio	75dB or better
Tone Controls: Switch at Box Speaker Position Switch at Driver Unit Position	Bass: ± 10dB at 100Hz Treble: ± 10dB at 10kHz Bass: -10dB at 100Hz Treble: ± 10dB at 10kHz
Output Taps for Speaker Matching	2 & 4Ω (for direct connections) 70 & 100V Line (for use with LMT)
Power Supply	AC: 220 - 240V 50 / 60Hz
Protection	AC: 14Amp. Circuit Protector, DC Circuit Protector : 2 × 32A
Rated AC Power Consumption	3400VA
Dimensions	W510 × H185 × D595 mm
Weight	38.50 Kg. approx.

- Design and Specifications are subject to change without notice owing to continuous product up-gradation.
- Technical specifications are subject to production tolerances.

AHUJA RADIOS • 215, Okhla Industrial Estate, New Delhi - 110 020, INDIA

Tel.: +91-11-26831549, 41612474 Fax : +91-11-26847287

E-mail: ahuja@ahujaradios.com, admin@ahujaradios.com Website: www.ahujaradios.com

- Design and Specifications are subject to change without notice owing to continuous product up-gradation
- Technical specifications are subject to production tolerances.
- We cannot be held responsible for printing errors, should they occur.
- **AHUJA** is a registered trademark of Ahuja Radios in India and other countries.
- © Copyright Ahuja Radios, 2017. All rights reserved. Any unauthorized reproduction or use of logos, images or design elements is strictly prohibited by law.
- No part of this compilation may be reproduced in any manner or translated without written permission.

