



FACTS

- Outer diameter: max. 390 mm
- Inner diameter: max. 190 mm
- Fieldbusses
- Fast Ethernet (certified to 100-BaseT CAT5e & Cat6)
- Flexibly configurable interfaces

ACCESSORIES ON REQUEST

- ADSR® - Slip ring diagnostic system

APPLICATION EXAMPLES

- Machine Tool • Packaging Machine



DATA

Number of rings:	max. 100	Rotation speed:	max. 50 rpm
Current per ring:	max. 300 A	Protection class:	IP54 / IP65
Voltage:	max. 690 V _{AC} / 1000 V _{DC}	Operating temperature:	-30 °C ... +70 °C
Dielectric strength:	2000 V _{AC}	Electrical connection:	customized (flying leads, cable or connector)
Insulation resistance:	>500 MΩ at 500 V _{DC}	Housing material:	Aluminium
		Length:	L ₁ on request

DESIGN EXAMPLE

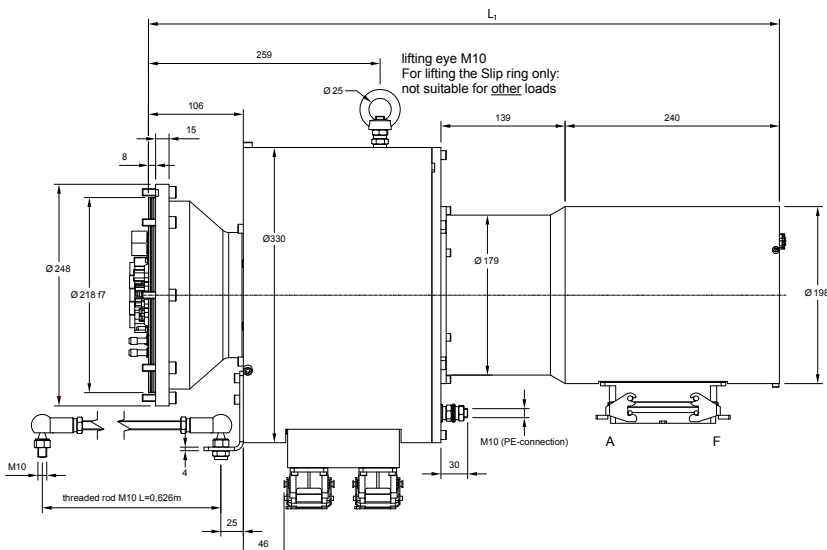



SLIP RING
SC3X0



Stated values are standard. Other configurations are available on request.
Subject to change without prior notice. Issued 07/2019

LTN Servotechnik GmbH
Georg-Hardt-Straße 4
83624 Otterfing, Germany
Tel: +49 (0)8024 6080-0
Fax: +49 (0)8024 6080-1000
ltn@ltn.de
www.ltn-servotechnik.de