

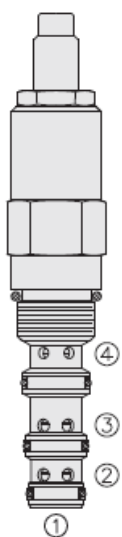

Overview



Description

The frr10-40 is a screw in, cartridge type, combination valve including a fixed orifice, pressure compensated, priority type flow regulator and a pressure relief valve.

Operation

With inlet at port 1 and ports 4 and 2 connected to tank, the valve maintains a constant flow rate from port 3 regardless of pressure variations at port 3.

Features

- Compact size.
- Two valve functions in one, industry-common cavity.
- Efficient - FR portion is vented.
- Quiet, modulated response.
- Hardened parts for long life.

Symbol

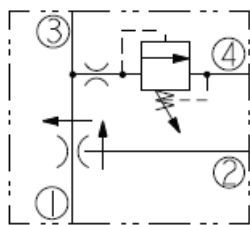

Ratings

Pressure Ratings

Pressure rating	207 bar (3000 psi) 276 bar (4000 psi)	- Note: Maximum system pressure
-----------------	--	--

Flow Ratings

Priority flow rating	2.8 to 18.9 lpm (0.75 to 5.0 gpm)
----------------------	-----------------------------------

Temperature Ratings

Operating fluid temperature	-40 to 100 °C (-40 to 212 °F) -26 to 204 °C (-15 to 400 °F)	- Note: With buna N seals - Note: With fluorocarbon seals
Storage temperature	-40 to 70 °C (-40 to 160 °F)	
Ambient temperature	-40 to 70 °C (-40 to 160 °F)	

Operating Parameters

Fluids	Mineral based or synthetic hydraulic fluid with lubricating properties
Fluid viscosity range	7.4 to 420 cSt
Maximum operating contamination level	18/16/13 per iso4406

Properties

Unit weight	0.29 kg (0.63 lb)
Internal wetted surface area	266 cm ² (41.2 in ²)



Performance

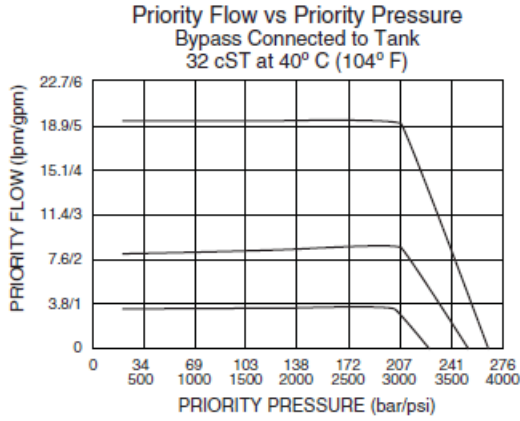

Dimensions

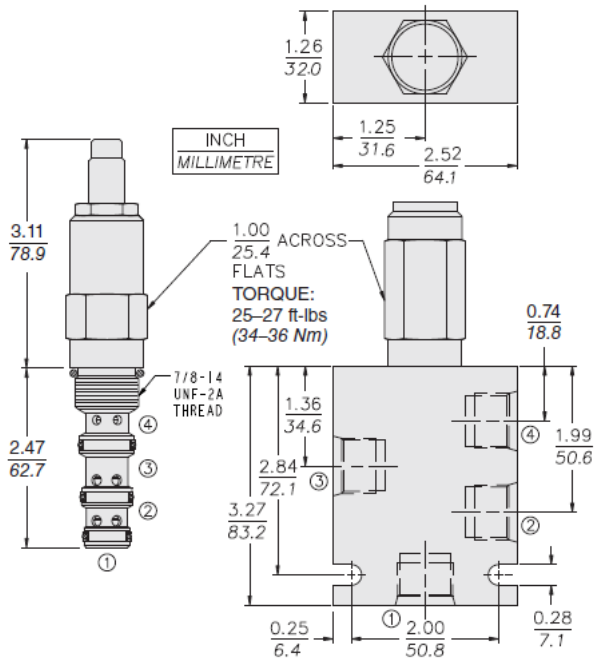

Installation Specifications

Cavity	VC10-4
Cartridge installation torque	34 to 37 N-m (25 to 27 ft-lb)
Orientation restriction	None

Accessories

Seal kit	SK10-4X-M	- Note: X = seal option
Housings		



Order Code

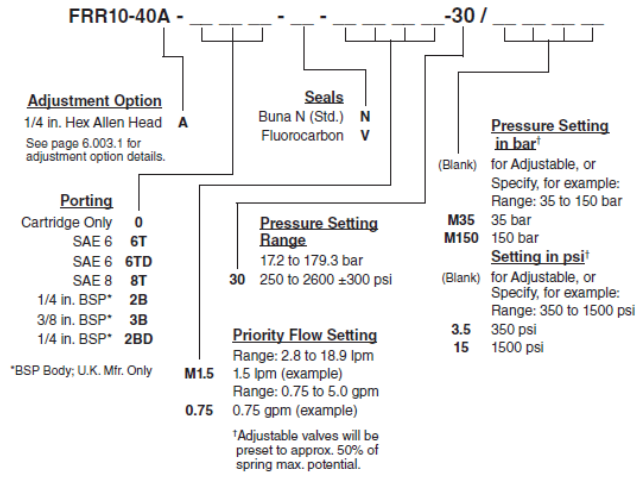

POSITION	CODE	DESCRIPTION
		FRR10-40A-H-J-S-T
H		Line Body
H	0	No Body
H	6T	Aluminum SAE 6
H	8T	Aluminum SAE 8
H	6TD	Ductile Iron SAE 6
J		Seal
J	N	Buna-N
J	V	Fluorocarbon
J	P	Polyurethane
S		Spring Setting
S	MXXX	Spring Setting in XXX bar
S	XX	Spring Setting in XX psi (x 100)
T		Flow Setting
T	XX	Flow Setting