

FMS Belt Scales / Measuring Rollers

BMGZ021-Series Robust measuring roller for flat conveyor belts

- **Longest lifetime**
Robust design, all components enclosed, integrated, contact-less speed detection
- **Precise measuring results**
10'000-times proven technology, direct force detection on the shaft, w/o deflection or any braces
- **Compact, maintenance-free**
Integrated speed detection without friction wheel, dual shaft sealings
- **Simple and universal retrofit**
Sophisticated and proven concept with multiple installation options

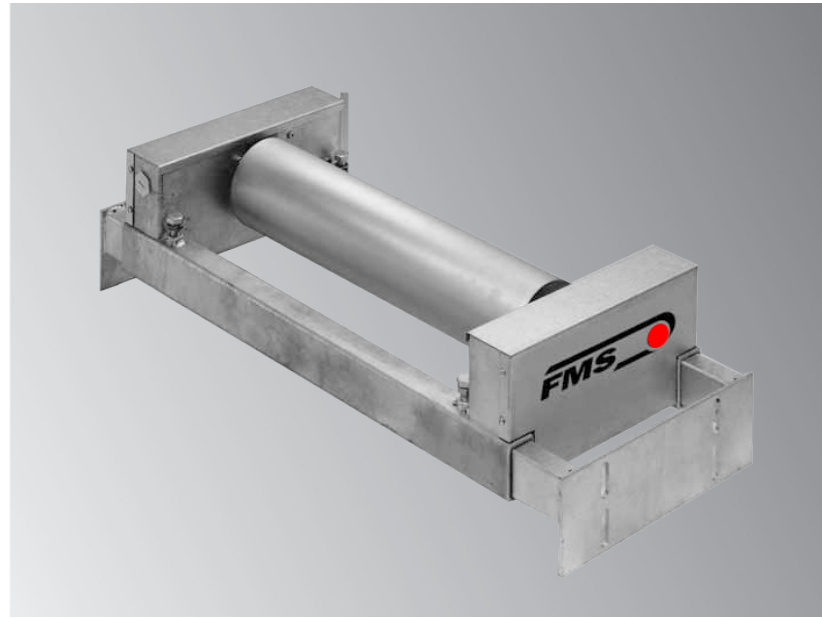

BMGZ021-Series

The flat measuring rollers of the BMGZ021-series are designed for operation in most severe conditions and under steady load in mobile and stationary plants that process heavy, bulky goods, such as sand, gravel, stones, coal, building rubble etc. A wide portfolio of sizes for standard belts offers solutions for most applications.

Functional description

The FMS measuring roller normally substitutes a regular idler roller station of the conveyor belt. The FMS measuring roller is selected according to the width of the conveyor belt. Both measuring roller axis are supported by force measuring sensors. This direct measurement at the point of load transmission makes the measuring system insensitive to forces that act in direction of the moving belt. Additional components (guiding beams and connections to the frame, etc.) to isolate the force are not required and lead to an extremely slim design. With an installation height of only 150 mm (5.9 in.) the FMS measuring roller can be easily installed where space is limited, e.g. in mobile crushers or screening plants. The adjustable support of the measuring roller can be adapted to various frame dimensions and widths. The mounting brackets simplify the installation and are also supplied. The integrated, sealed and contact-less speed detection is wear- and maintenance-free. It is also installed directly on the axis of the measuring roller.

BMGZ021-Series : Dimensions in mm (in.)

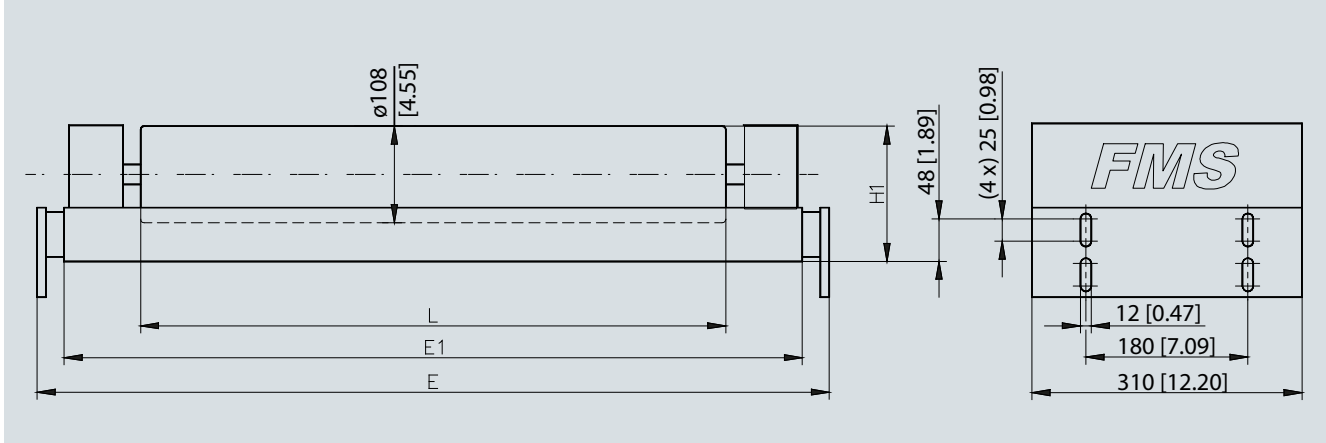

BMGZ021-Series : Dimensions

Type	Belt width mm (in.)	L mm (in.)	E mm (in.)	E1 mm (in.)	H1 mm (in.)
BMGZ021.020	400 (15.7)	400 (15.7)	600 - 970 (23.6 - 38.2)	580 (22.8)	150 (5.9)
BMGZ021.030	500 (19.7)	500 (19.7)	700 - 1070 (27.6 - 42.1)	680 (26.8)	150 (5.9)
BMGZ021.040	650 (25.6)	650 (25.6)	850 - 1220 (33.5 - 48.0)	830 (32.7)	150 (5.9)
BMGZ021.050	800 (31.5)	800 (31.5)	1000 - 1370 (39.4 - 53.9)	980 (38.6)	150 (5.9)
BMGZ021.060	1000 (39.4)	1000 (39.4)	1200 - 1570 (47.2 - 61.8)	1180 (46.5)	150 (5.9)

No loose cables, integrated speed detection

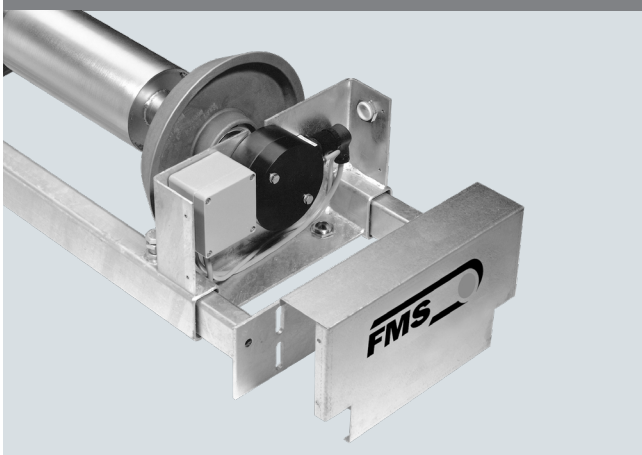

Measurement where the force is introduced, w/o levers

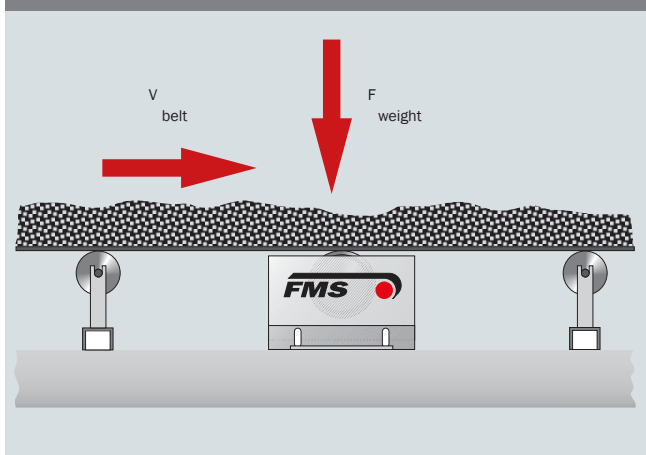

Proven force measurement with integrated overload protection

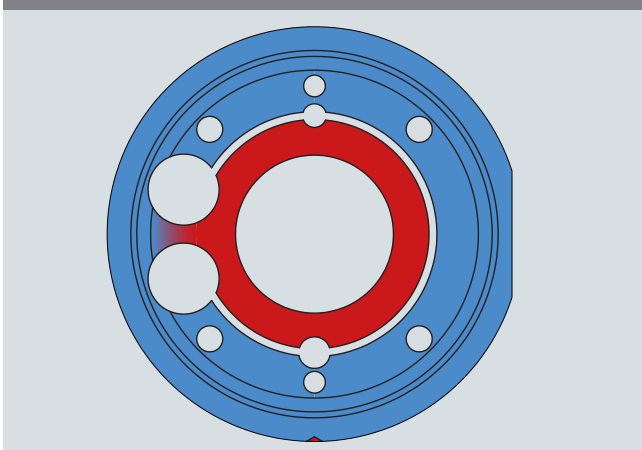

Versatile installation for most conveyor systems

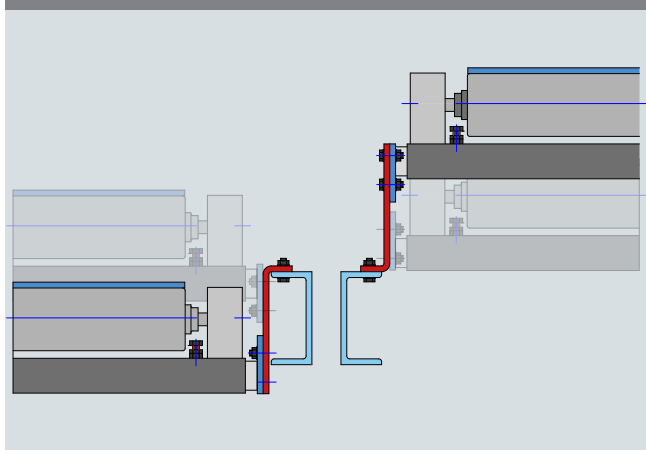

BMGZ021 : Technical data

Accuracy class	± 0.3 % (F _{Nenn})
Temperature range	-10 to +60 °C (14 to 140 F)
Overload protection force sensor	10 times nominal force (F _{Nom})
Material frame	galvanized steel
Protection class	IP67

BMGZ021 : Order code

BMGZ021.05034	
	Increment of speed detection
	Nominal force of the force sensor (encoded)
	Troughing angle (0°)
	Belt width (encoded)
	Series

BMGZ021 : Scope of supply

● measuring roller ● electronics (separate order) ● installation bracket ● no additional installation material

BMGZ021 : Accessories

● connection cable from measuring roller to electronics, 15 m (49 ft.) (other lengths on request)

BMGZ021 : Typical application



Other products : Construction and Recycling

BMGZ710 electronics



BMGZ041 measuring roller for troughed belts



About us

FMS Force Measuring Systems AG is the market leader in the field of web tension measurement, control and specialist for web guiding solutions. For the wire industry we are the only manufacturer offering a complete range of technologies for force measurement, data processing and radio transmission of signals.

Our in house developed products are used in the manufacturing industry, converting, metals, paper, textiles, as well as in cable and wire rope production. Utilising the latest technology, high quality components and a firm understanding of customer applications, FMS supports customers worldwide in the effort to maximize the productivity of their machines. Since 1993, our highly qualified employees have been creating high-end solutions for machine builders and plant operators. As an owner-managed company, we pride ourselves on being personal and approachable with the ability to make decisive moves fast.

World Headquarters: FMS Force Measuring Systems AG

Aspstrasse 6 • 8154 Oberglatt (Switzerland) • Phone + 41 44 852 80 80 • Fax + 41 44 850 60 06
info@fms-technology.com • www.fms-technology.com