

Ultrasonic process monitoring and flow measurement of hydrocarbons

Features

- Exact and highly reliable bidirectional clamp-on flow measurement of operational volumetric flow rate, mass flow rate and density
- Measurement of standard volumetric flow rate according to ASTM and API determination for hydrocarbon processing applications
- Compact, rugged, durable and maintenance-free meter for hazardous area locations
- Certification: ATEX/IECEX zone 1, FM Class I Div. 1+2
- Intrinsically safe analog process inputs for the integration of external pressure and temperature sensors at the measuring point
- Bidirectional communication and support of common bus technologies (Profibus PA, Foundation Fieldbus, HART, Modbus, BACnet)



Applications

Measurement on process and transport pipelines when processing hydrocarbons in single and multiproduct processes where changes in viscosity and density are affected by process conditions (pressure and temperature):
Leakage detection, fluid detection, interface/batch detection, fluid quality monitoring, check metering



Transmitter



Technical data

	FLUXUS H831 (831-AB*, 831-SB*)	FLUXUS H831 (831-ANN, 831-SNN)	FLUXUS H831**-F10
			
design	831-AB* (aluminum housing): explosion-proof field device or 831-SB* (stainless steel housing): explosion-proof offshore device zone 1 (intrinsic safety: outputs, inputs, process interfaces)	831-ANN (aluminum housing): explosion-proof field device or 831-SNN (stainless steel housing): explosion-proof offshore device zone 1	aluminum housing: explosion-proof field device FM
measurement			
• HPI			
standard volumetric flow rate			
• measurement uncertainty	%	±1 (crude oil, refined products, liquefied gases, heavy oils)	
• standard volumetric flow rate correction		VCF = CTL · CPL = ρ/ρ_N VCF - volume correction factor CTL - correction for the effect of temperature on liquid CPL - correction for the effect of pressure on liquid ρ - operating density ρ_N - normalised density	
operating density, normalised density			
• repeatability	%	±1 (with field calibration of sound speed)	
• flow			
measurement principle		transit time difference correlation principle, automatic NoiseTrek selection for measurements with high gaseous or solid content	
flow velocity	m/s	0.01...25	
repeatability		0.15 % MV ±0.005 m/s	
fluid		all acoustically conductive liquids with < 10 % gaseous or solid content in volume (transit time difference principle)	
temperature compensation		corresponding to the recommendations in ANSI/ASME MFC-5.1-2011	
measurement uncertainty (volumetric flow rate)			
measurement uncertainty of the measuring system ¹		±0.3 % MV ±0.005 m/s	
measurement uncertainty at the measuring point ²		±1 % MV ±0.005 m/s (see also graphical representation)	
transmitter			
power supply		20...32 V DC, $U_m = 120$ V	• 100...230 V/50...60 Hz or • 20...32 V DC
power consumption	W	< 4	< 8
number of measuring channels		1, optional: 2	
damping	s	0...100 (adjustable)	
measuring cycle	Hz	100...1000 (1 channel)	
response time	s	1 (1 channel), option: 0.02	
housing material		aluminum housing: cast aluminum EN AC 44200 mod, special heavy-duty coating (C5 according to EN ISO 12944) stainless steel housing: stainless steel 316/316L (1.4401, 1.4404, 1.4432)	cast aluminum EN AC 44200 mod, special heavy-duty coating (C5 according to EN ISO 12944)
degree of protection		IP66	TYPE 4X/IP66
dimensions	mm	see dimensional drawing	
mounting position		831-A*F (Profibus PA or FF H1), 831-S** : - nameplate faces upwards	
weight	kg	aluminum housing: 6.5, stainless steel housing: 15.6	
fixation		wall mounting, 2" pipe mounting	
ambient temperature	°C	aluminum housing: -40...+50/60 (< -20 without operation of the display) stainless steel housing: -20...+50/60	aluminum housing: -40...+60 (< -20 without operation of the display) stainless steel housing: -20...+60
display		128 x 64 pixels, backlight	
menu language		English, German, French, Spanish, Dutch, Russian, Polish, Turkish, Italian, Chinese	

¹ with aperture calibration of the transducers

² for transit time difference principle and reference conditions

³ outside the explosive atmosphere (housing cover open)

	FLUXUS H831 (831-AB*, 831-SB*)	FLUXUS H831 (831-ANN, 831-SNN)	FLUXUS H831**-F10
explosion protection			
• ATEX/IECEX			
marking	CE 0637 Ex II(1)2G II(1)2D Ex db eb ia [ia] IIC T6 Gb Ex tb ia [ia] IIC T100 °C Db 831-ABN: T _a -40...+60 °C 831-SBN: T _a -20...+60 °C 831-ABF: T _a -40...+50 °C 831-SBF: T _a -20...+50 °C	CE 0637 Ex II2G II2D Ex db eb IIC T6 Gb Ex tb IIC T100 °C Db 831-ANN: T _a -40...+60 °C 831-SNN: T _a -20...+60 °C	-
certification	IBExU20ATEX1103 X, IECEX IBE 20.0015X	IBExU20ATEX1103 X, IECEX IBE 20.0015X	-
• FM			
	-	-	 NI, Cl. I, II, III, Div. 2, GP A, B, C, D, F, G / T4A Cl. I Div. 1, GP. A, B, C, D / T6 For Group A, conduit seal of connection compartment is required within 18 inches. Cl. II, Div. 1, GP. E, F, G / T6 Cl. III, Div. 1 / T6 T _a = -40°C to +60°C  NI, Cl. I, II, III, Div. 2, GP A, B, C, D, F, G / T4A Cl. I Div. 1, GP. B, C, D / T6 Cl. II, Div. 1, GP. E, F, G / T6 Cl. III, Div. 1 / T6 T _a = -40°C to +60°C
measuring functions			
physical quantities	<ul style="list-style-type: none"> • flow: operating volumetric flow rate, standard volumetric flow rate according to ASTM 1250/TP25/4311, flow velocity, mass flow rate • HPI: API gravity, density, normalised density • interface detection: slope of the HPI physical quantities • fluid detection: according to fluid table 		
totaliser	volume, mass		
calculation functions	average, difference, sum (2 measuring channels necessary)		
diagnostic functions	sound speed, signal amplitude, SNR, SCNR, standard deviation of amplitudes and transit times		
communication interfaces			
service interfaces	measured value transmission, parametrisation of the transmitter: USB ³		
process interfaces	intrinsic safety, max. 1 option: <ul style="list-style-type: none"> • HART • Profibus PA • FF H1 	max. 1 option: <ul style="list-style-type: none"> • Modbus RTU/RS485 • HART • Profibus PA • FF H1 • BACnet MS/TP 	
accessories			
data transmission kit	USB cable		
software	<ul style="list-style-type: none"> • FluxDiagReader: reading of measured values and parameters, graphical representation • FluxDiag (optional): reading of measurement data, graphical representation, report generation, parametrisation of the transmitter 		
data logger			
loggable values	all physical quantities, totalised physical quantities and diagnostic values		
capacity	max. 800 000 measured values		

¹ with aperture calibration of the transducers

² for transit time difference principle and reference conditions

³ outside the explosive atmosphere (housing cover open)

		FLUXUS H831 (831-AB*, 831-SB*)	FLUXUS H831 (831-ANN, 831-SNN)	FLUXUS H831**-F10
outputs				
The outputs are galvanically isolated from the transmitter.				
• switchable current output				
		configurable according to NAMUR NE43 All switchable current outputs are jointly switched to active or passive.		
number		-	max. 3	
range	mA	-	4...20 (3.2...24)	
accuracy		-	0.04 % MV ±3 µA	
active output		-	R _{ext} < 530 Ω	
passive output		-	U _{ext} = 9...30 V, depending on R _{ext} (R _{ext} < 458 Ω at 20 V)	
current output in HART mode		-	option	
• range	mA	-	4...20 (3.5...22)	
• active output		-	R _{ext} = 250...530 Ω	
• passive output		-	U _{ext} = 9...30 V DC	
• current output				
		configurable according to NAMUR NE43		
number		-	max. 3	
range	mA	-	4...20 (3.2...24)	
accuracy		-	0.04 % MV ±3 µA	
passive output		-	U _{ext} ≤ 29 V DC, depending on R _{ext} (R _{ext} < 830 Ω at 29 V)	
current output in HART mode		-	option	
• range	mA	-	4...20 (3.5...22)	
• passive output		-	U _{ext} = 9...29 V DC	
intrinsic safety parameters		-	U _i = 29 V I _i = 100 mA P _i = 0.725 W C _i = 1 nF L _i = 50 nH	
• digital output				
functions		• frequency output • binary output • pulse output	• frequency output • binary output • pulse output	
number		max. 2	max. 3	
operating parameters		U _{ext} = (8.2 ±0.1) V DC	U _{ext} = (8.2 ±0.1) V DC	
frequency output				
• range	kHz	0...10	0...10	
binary output				
• binary output as alarm output		limit, change of flow direction or error	limit, change of flow direction or error	
pulse output				
• pulse value	units	0.01...1000	0.01...1000	
• pulse width	ms	0.05...1000	0.05...1000	
intrinsic safety parameters		U _i = 29 V I _i = 100 mA P _i = 0.725 W C _i = 1 nF L _i = 50 nH		

¹ with aperture calibration of the transducers

² for transit time difference principle and reference conditions

³ outside the explosive atmosphere (housing cover open)

	FLUXUS H831 (831-AB*, 831-SB*)	FLUXUS H831 (831-ANN, 831-SNN)	FLUXUS H831**-F10
inputs			
	not short-circuit proof The inputs are not galvanically isolated from the transmitter.	The inputs are galvanically isolated from the transmitter.	
• temperature input			
number	max. 1	max. 1	
type	Pt100/Pt1000	Pt100/Pt1000	
connection	4-wire	4-wire	
range	°C -150...+560	-150...+560	
resolution	K 0.01	0.01	
accuracy	±0.01 % MV ±0.03 K	±0.01 % MV ±0.03 K	
intrinsic safety parameters	U _o = 9.2 V I _o = 25 mA P _o = 0.057 W C _o = 4283 nF L _o = 57 mH	-	
• switchable current input			
	All switchable current inputs are jointly switched to active or passive.		
number	-	max. 2	
accuracy	-	±0.1 % MV ±0.01 mA	
active input	-	U _{out} = max. 28 V, R _{int} = 75 Ω	
• range	mA -	0...24	
passive input	-	R _{int} = 35 Ω, U _{out} = 26 V, I _{max} ≤ 24 mA	
• range	mA -	0...20	
• current input			
number	max. 1	-	
accuracy	±0.1 % MV ±0.01 mA	-	
active input	U _{int} < 20 V, R _{int} = 360 Ω	-	
• range	mA 0...20	-	
intrinsic safety parameters	U _o = 29.2 V I _o = 88 mA P _o = 0.64 W C _o = 73 nF L _o = 4.1 mH	-	

¹ with aperture calibration of the transducers

² for transit time difference principle and reference conditions

³ outside the explosive atmosphere (housing cover open)

Dimensions

***831 (aluminum housing)**

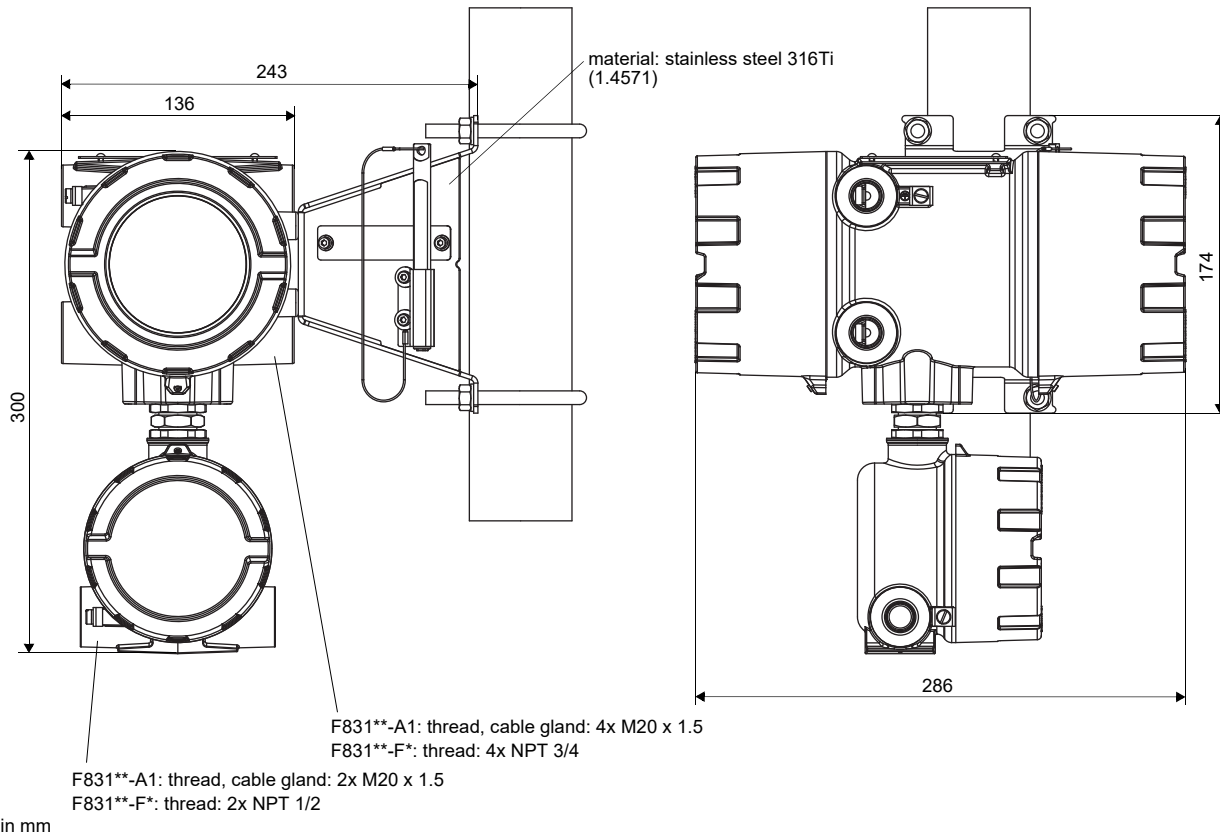

***831 (stainless steel housing)**

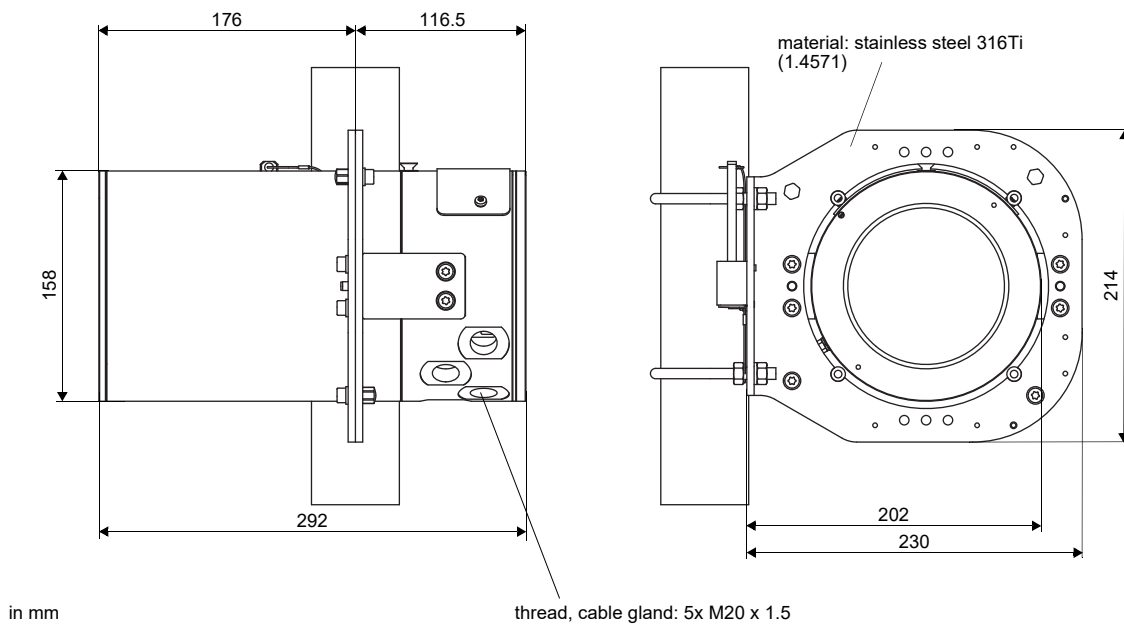

Wall and 2" pipe mounting kit

*831 (aluminum housing)

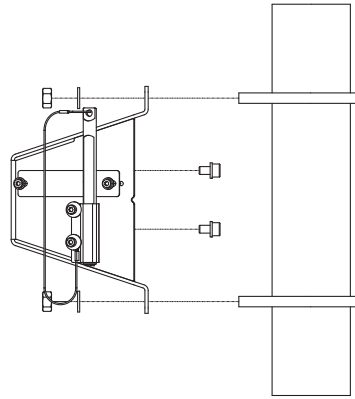

*831 (stainless steel housing)

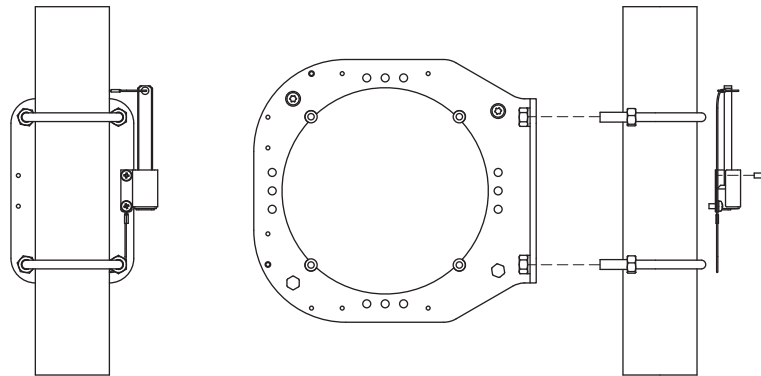

Storage

- do not store outdoors
- store within the original package
- store in a dry and dust-free place
- protect against sunlight
- keep all openings closed
- storing temperature:
 - aluminum housing: -40...+60 °C
 - stainless steel housing: -20...+60 °C

Terminal assignment

***831 (aluminum housing)**

upper housing, back view
 831-AA*, 831-AB*: Ex e, Ex i
 831-ANN: Ex e
 *831**-F*: XP, DIP, NI

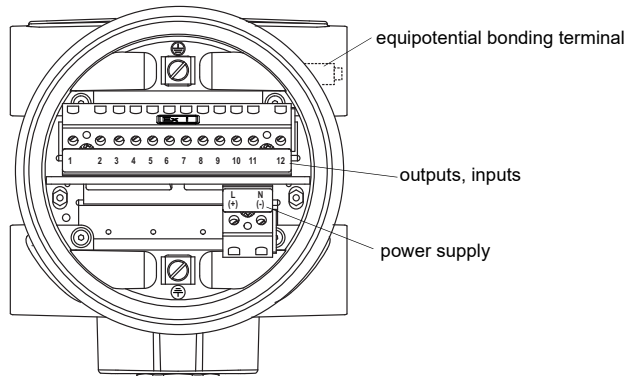

lower housing, front view
 831-A**: Ex e
 *831**-F*: XP, DIP, NI

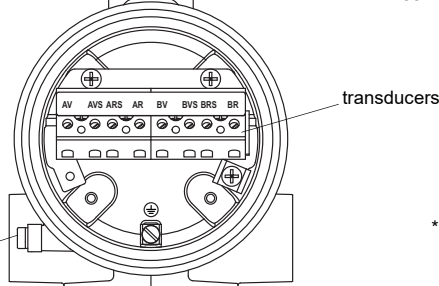

831-AA*, 831-AB*: Ex e, Ex i
 831-ANN: Ex e
 *831**-F*: XP, DIP, NI

831-A**: Ex d
 *831**-F*: XP, DIP, NI

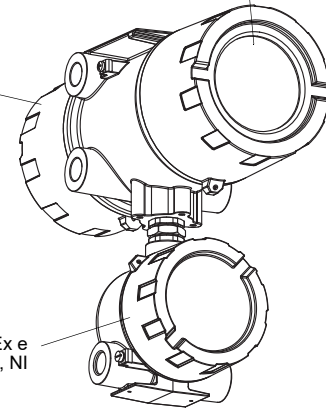

831-A**: Ex e
 *831**-F*: XP, DIP, NI

***831 (stainless steel housing)**

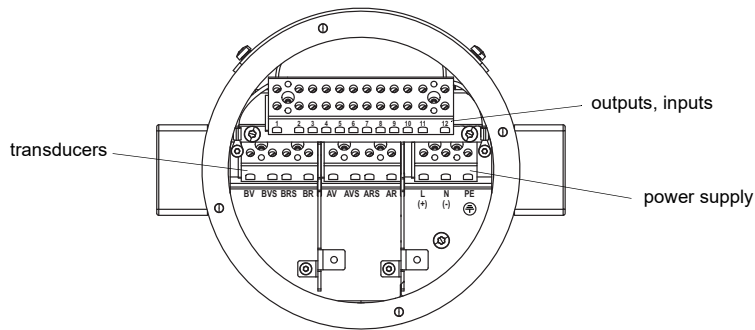

power supply¹

AC		DC	
terminal	connection	terminal	connection
L	phase	(+)	+
N	neutral	(-)	-

¹ cable (by customer): e.g. flexible wires, with insulated wire ferrules, wire cross-section: 0.25...2.5 mm²

transducers, extension cable

measuring channel A		measuring channel B		transducer
terminal	connection	terminal	connection	
AV	signal	BV	signal	↑
AVS	internal shield	BVS	internal shield	↕
ARS	internal shield	BRS	internal shield	↕
AR	signal	BR	signal	↕
cable gland	external shield	cable gland	external shield	↑ ↕

outputs, inputs^{1, 2}		
terminal	connection	
depending on configuration	passive current output, digital output, current input	
3, 4, 5, 6	temperature input	
11+, 12-	passive current output/HART	
11-, 12+	active current output/HART	
11, 12	Modbus RTU, FF H1, Profibus PA, BACnet MS/TP	
temperature probe		
terminal	direct connection	connection with extension cable
3	red	blue
4	red	grey
5	white	white
6	white	red
USB	type C Hi-Speed USB 2.0 Device	service (FluxDiag/FluxDiagReader)

¹ cable (by customer): e.g. flexible wires, with insulated wire ferrules, wire cross-section: 0.25...2.5 mm²

² The number, type and terminal assignment are customised.

Transducers

Overview

Shear wave transducers

	technical type						
	G	K	M	P	Q	S	
zone 1 normal temperature range	CDG1N81 CLG1N81	CDK1N81 CLK1N81	CDM2N81 CLM2N81	CDP2N81 CLP2N81	CDQ2N81 CLQ2N81		
zone 1 IP68	CDG1L11	CDK1L11	CDM2L11	CDP2L11			
zone 1 extended temperature range	CDG1E83 CLG1E83	CDK1E83 CLK1E83	CDM2E85 CLM2E85	CDP2E85 CLP2E85	CDQ2E85 CLQ2E85		
FM Class I Div. 1 normal temperature range	CDG1N62 CLG1N62	CDK1N62 CLK1N62	CDM1N62 CLM1N62	CDP1N62 CLP1N62	CDQ1N62 CLQ1N62		
FM Class I Div. 2 normal temperature range	CDG1N53 CLG1N53	CDK1N53 CLK1N53	CDM2N53 CLM2N53	CDP2N53 CLP2N53	CDQ2N53 CLQ2N53	CDS2N53	
FM Class I Div. 2 extended temperature range			CDM2E53 CLM2E53	CDP2E53 CLP2E53	CDQ2E53 CLQ2E53		
inner pipe diameter d							
min. extended	mm	400	100	50	25	10	6
min. recommended	mm	500	200	100	50	25	10
max. recommended	mm	4000	2000	1000	400	150	70
max. extended	mm	6500	2400	1200	480	240	70
pipe wall thickness							
min.	mm	11	5	2.5	1.2	0.6	

for further data see Technical specification TS_F8xx-transducersVx-xxx_Leu

Transducer mounting fixture

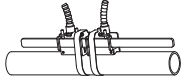
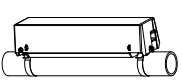
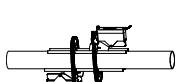
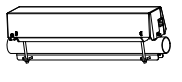
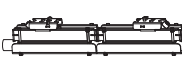
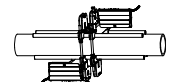
Variofix L	Variofix C	PermaFix	transducer box WI for Wavelinjector with chains
	 transducer frequency S		
	Variofix C with bolt mounting plates	PermaFix with bolt mounting plates	transducer box WI for Wavelinjector with threaded rods
	 outer pipe diameter: VCM: max. 46 mm VCC: max. 36 mm		 outer pipe diameter: 35...380 mm

for further data see Technical specification TS_F8xx-transducersVx-xxx_Leu

Coupling materials for transducers

	normal temperature range		extended temperature range			Wavelinjector	
	< 100 °C	< 170 °C	< 150 °C	< 200 °C	200...240 °C	< 280 °C	280...630 °C
< 24 h	coupling compound type N or coupling foil type VT	coupling compound type E or coupling foil type VT	coupling compound type E or coupling foil type VT	coupling compound type E or H or coupling foil type VT	coupling foil type TF	coupling foil type A and coupling foil type VT	coupling foil type B and coupling foil type VT
long time measurement	coupling foil type VT	coupling foil type VT	coupling foil type VT	coupling foil type VT			

for further data see Technical specification TS_F8xx-transducersVx-xxx_Leu

Connection systems

connection system T1		
connection with extension cable	direct connection	transducers technical type
		****53
<p>JB01</p>		****8*
<p>JB01</p>		****L1*
<p>terminal board for junction box (junction box by customer)</p>		****62

for further data see Technical specification TS_F8xx-transducersVx-xxx_Leu

Temperature probes

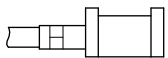
PT12N (order code: ACC-PE-****-/T332)	PT12N (order code: ACC-PE-****-/T382)
<ul style="list-style-type: none">• clamp-on• ATEX zone 0/1 (intrinsic safety)• for 831-AA2, 831-AA3	<ul style="list-style-type: none">• clamp-on• ATEX zone 1• for 831-ANN
-45...+230 °C	-45...+250 °C
	

see Technical specification TS_PTVx-xXX