

DOL 434

Climate Controller

Technical Info



1	Product description	4
1.1	Climate control.....	4
1.1.1	LPV (Low Power Ventilation)	4
1.2	Functionality.....	5
2	Product survey	8
2.1	DOL 430 hardware	8
2.2	DOL 434 software.....	9
2.3	Languages	9
2.4	Accessories.....	10
3	Technical data	15
3.1	Dimensioned sketch	16
3.2	Minimum requirements with shared equipment	17

1 Product description

DOL 434 is a one-house controller developed especially for livestock houses with LPV ventilation. It meets the requirements for climate control especially in temperate climate. Also the DOL 434 includes functions for water, 24-hour clock and additional sensors.

The controller is operated via a large touch display with graphical views of the ventilation status, icons and curves, among other things. The pages shown in the display may be adapted in accordance with the user requirements so that the most frequently used working procedures are easily accessible.

DOL 434 has two LAN ports for connection to FarmOnline and two USB ports.

1.1 Climate control

1.1.1 LPV (Low Power Ventilation)

The LPV variant is a classic control for a low-pressure system. The system can be suited for most houses. The system is designed for the temperate parts of the world. Fresh air is supplied to the house by means of either wall, ceiling or roof inlets, and the climate is regulated by adjusting the speed in which the air is supplied to the house, among other things.

LPV ventilation works according to the mixing principle. Fresh air from the inlets is mixed with the housing air before it is extracted through the exhaust units in the roof or wall.

- Fresh air at low outside temperature (Minimum ventilation)
- Cooling at high outside temperatures (Extra ventilation)

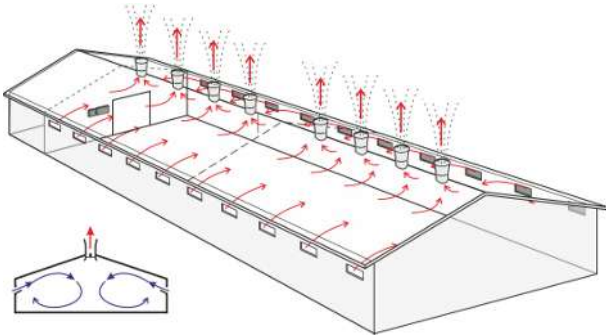

Air intake: Inlets positioned in outer wall or ceiling.

Air outlet: Exhaust units positioned in the roof or wall.

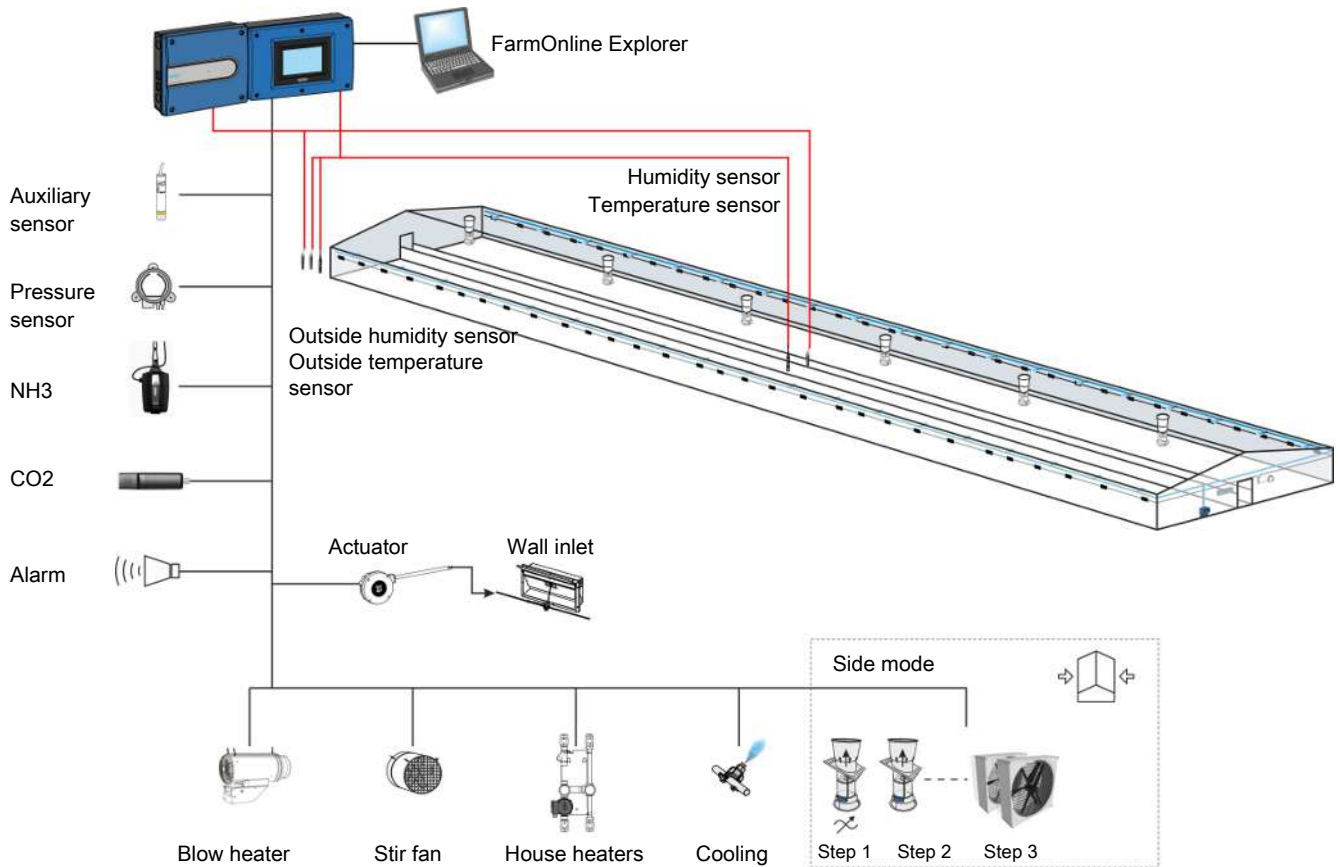

Figure 1: Examples of connection in an LPV house

1.2 Functionality

	DOL 434 LPV
System software	
Ventilation mode	
LPV	X
Ventilation and temperature	
Outside temperature sensor	X
Inside temperature sensor	X
Air inlet	
Side inlet	6
Roof inlet	X
Air outlets	
Side outlet - stepless group	2
Number of flaps in each stepless group	1
Side MultiStep	3
External fan stop	X
Parking of fans	X
Minimum ventilation in % and m ³ /animal	X
PID control (or P-band)	X

	DOL 434 LPV
System software	
Cycle timer minimum side ventilation	X
Active pressure control - inlets	X
Comfort control	X
Day and night adjustment	X
Extra ventilation	X
Sharing outside temperature sensor	X
CO2 minimum ventilation control	X
NH3 ventilation	X
Air circulator	6
Display of user-offset for temperature set-point	X
Heating	
Number of room heating units	6
Number of stand-alone heaters	4
Adaptive heating control (room heating and stand alone heaters)	X
Humidity	
Inside humidity sensor	2
Outside humidity sensor	X
Sharing outside humidity sensor	X
Humidity control via "humidity ventilation"	X
Humidity control via "temperature reduction"	X
Humidity control via "heating control"	X
Humidification control	X
Adaptive humidity control	X
Intelligent humidity control by outdoor conditions	X
Cooling	
Side cooling	3
Cooling before maximum ventilation	X
Nozzle cleaning (side cooling)	X
Production	
Water meter	4
Light	X
Light dimmer	X
Light sensor	5
Boost function	X
Light dimmer controlled by light sensor	X
24-hour clock	4
Miscellaneous	
Spraying	X
Auxiliary sensor	16

	DOL 434 LPV
System software	
Curve control (temp., humidity, min. vent, max. vent.)	X
History curves	X
Ventilation boost	X
In-between function (soaking/washing/drying)	X
User defined page views	X
Safety	
Three password levels	X
Comprehensive alarm functions	X
Operation and alarm logs	X
Support of emergency opening DOL 278T	X
Energy consumption monitoring	2
Status on equipment (current sensor)	64
Remote Access (via FarmOnline)	X

2 Product survey

2.1 DOL 430 hardware

The standard hardware contains I/O module type 3. Inputs and outputs are described for each type. See below. The 0-10 V inputs and outputs of the main module can be configured in the following way:

- 11 inputs and 2 output - or
- 9 inputs and 4 output - or
- 7 inputs and 6 outputs



136094 DOL 430 controller, 10" Small 12RL

12 V power supply - 1.25 A
 DOL 12 outside temperature sensor (1)
 0-10 V input or 0-10 V output (2+2)
 0-10 V input or DOL 12 input (4)
 0-10 V input (2)
 0-10 V output (2)
 Relays (12)

There is room for an extra I/O module in the box.

No documentation is supplied with the controller. Manual packages must be ordered separately in the relevant language, see section Languages [► 9].



136095 DOL 430 controller, 10" Large 12RL

12 V power supply - 1.25 A
 DOL 12 outside temperature sensor (1)
 0-10 V input or 0-10 V output (2+2)
 0-10 V input or DOL 12 input (4)
 0-10 V input (2)
 0-10 V output (2)
 Relays (12)

There is room for an extra I/O module in the box.

No documentation is supplied with the controller. Manual packages must be ordered separately in the relevant language, see section Languages [► 9].



136096 DOL 430 controller, 10" Large 22RL

12 V power supply - 1.25 A
 DOL 12 outside temperature sensor (1)
 0-10 V input or 0-10 V output (2+2)
 0-10 V input or DOL 12 input (4)
 0-10 V input (10)
 0-10 V output (10)
 Relays (22)

There is room for an extra I/O module in the box.

No documentation is supplied with the controller. Manual packages must be ordered separately in the relevant language, see section Languages [► 9].



136098 DOL 430 controller, 10" Large 32RL

12 V power supply - 1.25 A
 DOL 12 outside temperature sensor (1)
 0-10 V input or 0-10 V output (2+2)
 0-10 V input or DOL 12 input (20)
 0-10 V input (2)
 0-10 V output (18)
 Relays (32)

No documentation is supplied with the controller. Manual packages must be ordered separately in the relevant language, see section Languages [► 9].

2.2 DOL 434 software

Software is available as:

System software: basic functionality.

Software update: new version of existing software with new functionality.

System software

Climate software



136121 DOL 434 LPV MS-3, climate SW

LPV ventilation with 3 MultiStep

Software update



136948 DOL 43X/53X/63X Update to latest version

When updating the DOL 43X/ 53X/63X software, the FarmOnline Explorer management program requires update to the latest version.

The controller must have an IMX Quad-core CPU to use this software.

2.3 Languages

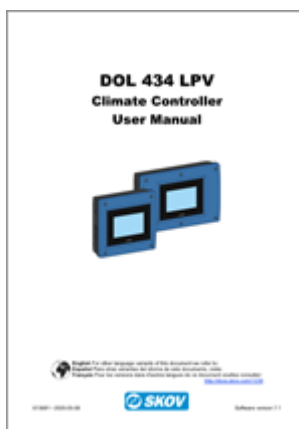

137640 DOL 434 LPV manual package DA

137641 DOL 434 LPV manual package EN

137642 DOL 434 LPV manual package DE

The manual package contains user documentation in the selected language and an English technical manual. Some manual packages include the technical documentation in the chosen language.

Language in the computer display	DA – Danish	TH – Thai
	EN – English	ZH – Chinese
	DE – German	SR – Serbian
	NL – Dutch	ET - Estonian
	FR – French	PT – Portuguese
	ES – Spanish	ID – Indonesian
	FI – Finnish	KO – Korean
	SV – Swedish	FA – Farsi
	CS – Czech	AR – Arabic
	PL – Polish	SQ – Albanian
	RU – Russian	BG – Bulgarian
	HU – Hungarian	VI – Vietnamese
	IT – Italian	UR – Urdu
	RO – Romanian	KH – Khmer
	SL – Slovenian	IS – Icelandic
	HR – Croatian	UK – Ukrainian
	TR – Turkish	EL – Greek
	JA – Japanese	LT – Lithuanian

2.4 Accessories



140252 DOL 114 humidity and temperature sensor, 2 m cable

140253 DOL 114 humidity and temperature sensor, 5 m cable

The DOL 114 is a dual-purpose temperature and humidity sensor that can be used to regulate the livestock house relative air humidity and temperature.

The DOL 114 is a high-quality sensor which is especially useful under particularly harsh conditions and in areas of high air humidity.

The DOL 114 comes with a protective cap.

In general, SKOV A/S recommends that a humidity sensor be installed in livestock houses integrating heat supply.

Climate controllers on the same LAN network can share an outside humidity sensor.



140263 DOL 104 humidity sensor 0-10 V

DOL 104 is a high-precision humidity sensor that can be used for regulating the relative air humidity in the livestock house.

The DOL 104 is a high-quality sensor which is especially useful under particularly harsh conditions and in areas of high air humidity.

DOL 104 has full protection against short circuits and wiring failures.

The DOL 104 comes with a protective cap.

If you want humidity and temperature measurement on two individual sensors DOL 104 can i.a. be used.

In general, SKOV A/S recommends that a humidity sensor be installed in livestock houses integrating heat supply.

**140200 DOL 12 temperature sensor, 1.4 m cable****S140200A DOL 12 temperature sensor, 5 m cable**

An outside temperature sensors are supplied with the climate controller as a standard.

Order the required number of sensors for registration of inside temperature. The climate controller is not supplied with a inside temperature sensor.

In large houses, up to eight extra temperature sensors can be connected, resulting in an average measurement by several sensors per zone.

**140245 Climate sensor radiation shield**

The radiation shield protects an outside temperature and/or humidity sensor from rain and radiant heat.

SKOV A/S recommend that the Climate sensor radiation shield is positioned 2 m above the roof. Alternatively 2 m above the ground and 2 m from other building elements (walls etc.)

The radiation shield is supplied with a mounting bracket.

It may be necessary to order a climate sensor with a long cable when using the radiation shield.

**140331 DOL 119 CO2 sensor 5000/10000 ppm**

Sensor for measuring the CO2 content in the air.

Registration of the CO2 content of the air allows the house controller to regulate the minimum ventilation.

If a CO2 sensor has not been installed, the house controller regulates the minimum ventilation on the basis of the set values (m3/h per animal).

Supplied with a M12 plug and sealing plug as well as protection cap for DOL 119.

**140269 Cable 2 m M12 plug incl. sealing plug**

2 meter cable for DOL 119/DOL 16 with M12 plug and sealing plug.

When replacing DOL 19 with DOL 119, the cable must be replaced or the connection must be moved.

**140333 DOL 18 v2 elec. sub-pressure sensor 100 Pa****140334 DOL 18 v2 elec. sub-pressure sensor 300 Pa**

Sensor for measuring the pressure level in the house.

The electronic pressure sensor facilitates active pressure control. Based on the measured pressure the house controller regulates the air inlets so the required pressure is maintained in the house.

The sub-pressure sensor can be installed inside the house controller.

DOL 18 hose set must be ordered separately.

**140235 DOL 18 hose set**

Hose set for DOL 18 electronic sub-pressure sensor.

**300085 Transparent plastic hose $\varnothing 7 \times 5$**

3 meters.

To be used if additional plastic hose is needed.

**437672 Extension nipple & 5/7 PVC tube set**

Extension nipples must be ordered if another hose type than 300085/140235 is used.

**140232 DOL 58 weather sensor**

The DOL 58 measures wind direction, wind speed and air pressure/temperature (optional). Wind speed and direction are measured using ultrasound.

Can be used as an extra sensor.

**413232 House board**

For mounting of climate sensors.

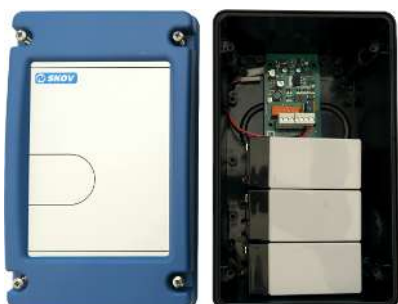
**134718 Mini Power Backup Unit, 20V 1A**

The mini power backup unit is designed to be installed at the side of and connected to a controller. At 115 V /230 V mains failure the mini power backup unit safeguards the controller against disturbances from brief power failures, when the controller otherwise would restart. The mini power backup unit is typically used where there is no emergency opening.

A mini power backup unit must only be connected to one controller if:

- the controller has a maximum of 6 I/O modules and
- consumption from the main module does not exceed 0.4 A and
- consumption from the I/O modules does not exceed 0.4 A.

Backup time

Average backup time: 5 minutes per hour

Max. Backup time: 0.5 – 3 hours with fully charged battery

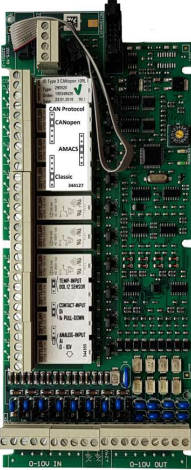

136659 IO type 3 CANopen 10RL 8AI 8AO

The house controller's standard software/hardware supports 13 I/O modules in total.

There is room for the following number of I/O modules in the various cabinets:

Controller Small (1)

Controller Large (2)

If more I/O modules are needed, extra modules can be put in a universal box (134731 and 134732).

Relays (10)

0-10 V inputs (8)

0-10 V outputs: (8)

The inputs can be configured individually for either DOL 12, DI (for water meters) or AI (0-10 V input).

When temperature-controlled emergency opening (DOL 278T) activates, you can use a jumper to configure which relays to interrupt.

Using a jumper, all 0-10 V inputs can be configured as either a DOL 12 input or a digital input.



134941 Set for installation in more levels

Used when two I/O modules are mounted above each other, or when the I/O module is mounted above the internal speed control.



136470 DOL 530/630 Ext. box Small 10RL

Extension box with 1 pcs. I/O module, 10RL 8AI 8AO, type 3.

Includes rubber sleeves and ribbon cable

10 x relays

8 x 0-10V inputs

8 x 0-10V outputs

The inputs can with a jumper be configured individually for either DOL 12, DI (digital input) for water meters or AI (analog input, 0-10 V).



136471 DOL 530/630 Ext. box Small 20RL

Extension box with 1 pcs. I/O module, 10RL 8AI 8AO, type 3.

Includes rubber sleeves and ribbon cable

20 x relays

16 x 0-10V inputs

16 x 0-10V outputs

The inputs can with a jumper be configured individually for either DOL 12, DI (digital input) for water meters or AI (analog input, 0-10 V).



134703 M25 cable glands (30 pcs.)

Plastic gland and plastic nut for mounting in a house controller or box. Can be used when mounting cables in size $\varnothing 9-17$ mm.

3 Technical data

Electrical		
Rated voltage	V AC	115*, 200* and 230/240 (*not speed controller)
Operating voltage	V AC	103.5-264
Frequency	Hz	50/60
Effect	W	75
Max. current consumption	A	0.7
Main module		
Configurable main module.		Number 0-10 V: - 11 inputs and 2 outputs – or - 9 inputs and 4 outputs – or - 7 inputs and 6 outputs
Inputs		7 x 0-10 V DC input impedance 2.1 mOhm.
Outputs/power supply		2 x 15 V DC power supply +/- 10 % max. 40 mA in total.
		2 x motor supply 24 V DC +/- 20 % max. 0.4 A (in total for the entire controller).
		2 x supply for winch motor potentiometer 10 V DC max. 40 mA in total.
		2 x 0-10 V DC Output impedance 100 Ohm.
Relays		12 x NO/NC potential free Max. voltage/current at resistive load 250 V AC / 5 A AC. Max. voltage/current at inductive load 250 V AC / 2A AC CosPhi 0.8. 1 x alarm relay NC, max. 24 V 2 A. Min. 12 V 10 mA (resistive load).
I/O module type 15		
IO type 15, 10RL 8AI 8AO		No jumpers. Requires external resistors for use with e.g., water meters. Comes with resistors.
Inputs		8 x 0-10 V DC input impedance 2.1 mOhm.
Pulsing Inputs (e.g. water meter, energy meter)		Minimum pulse length: 75 ms. Minimum pulse interval: 75 ms. Maximum frequency/pulse per sec.: 6 Hz.
Outputs/power supply		8 x 0-10 V DC output impedance 10 Ohm.
		1 x motor supply 24V DC +/- 20%, 0.4 A.
Relays		10 x NO/NC potential free max. Max. voltage/current at resistive load 250 V AC / 5 A AC. Max. voltage/current at inductive load 250 V AC / 2A AC CosPhi 0.8.
I/O module type 3		
IO type 3, 10RL 8AI 8AO		With jumpers for configuration of inputs.
Inputs		8 x 0-10 V DC input impedance 2.1 mOhm.
Pulsing Inputs (e.g. water meter, energy meter)		Minimum pulse length: 75 ms. Minimum pulse interval: 75 ms. Maximum frequency/pulse per sec.: 6 Hz.
Outputs/power supply		8 x 0-10 V DC output impedance 10 Ohm.
		1 x motor supply 24V DC +/- 20% 0.4 A
Relays		10 x NO/NC potential free max. Max. voltage/current at resistive load 250 V AC / 5 A AC. Max. voltage/current at inductive load 250 V AC / 2A AC CosPhi 0.8.
Network		

Network interface		
Network interface		2 x 10/100 BASE+TX RJ 45
USB		
USB		2 x USB 2.0 A type
Accessories		
Speed control (output)		Motor load max. 6.8 A 230-240 V AC/min. 150 W.
Environment		
Operating temperature	°C (°F)	-10 to +45 (+14 to 113)
Storage temperature	°C (°F)	-25 to +60 (-13 to +140)
Ambient humidity, operation	% RH	0-80
Protection class	IP	54 (splashproof) It is assumed that the base surface is flat, i.e. ≤ there is a 1.5 mm difference in height, and the front panel screw is tightened to a minimum of 1.5 Nm. 1.5 Nm.

Mechanical			
Cable knock-out punches			
		Large	Small
		30 x M25 For metrical cable glands	20 x M25 For metrical cable glands
Shipment			
		Large	Small
Dimensions (H x W x D)	mm	381 x 568 x 170	381 x 400 x 170
Dimensions crated H x W x D	mm	421 x 608 x 230	425 x 555 x 195
Weight	g	7800	5800
Shipping weight	g	9200	6900

3.1 Dimensioned sketch

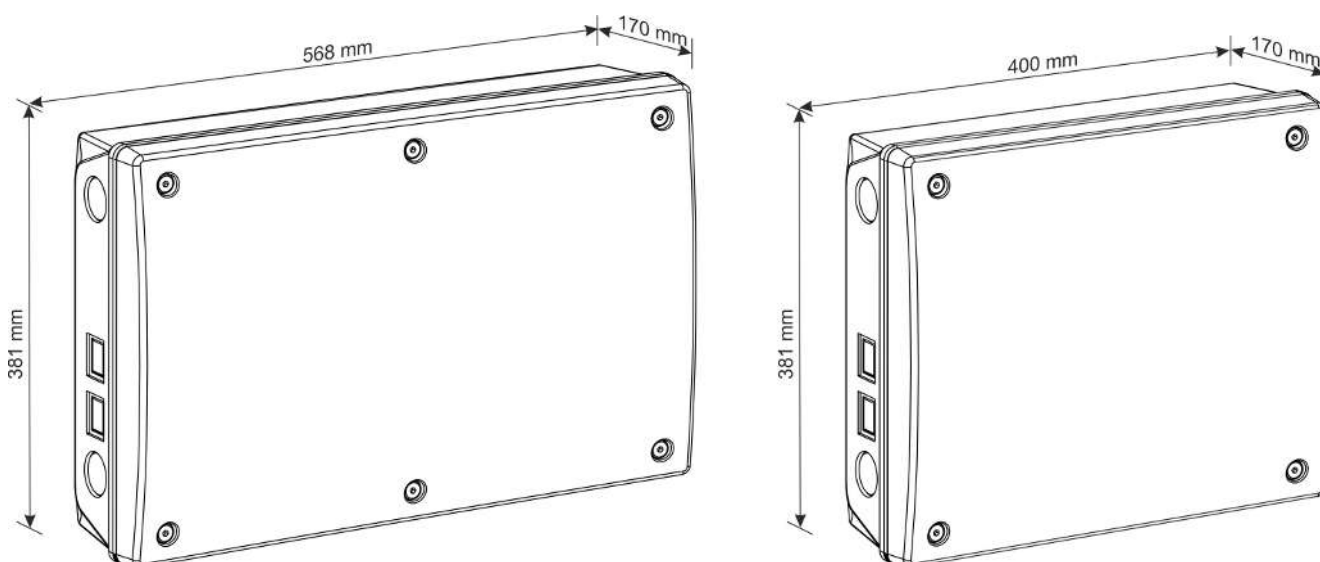

3.2 Minimum requirements with shared equipment

House controllers that are connected to a common network (LAN) can share equipment such as sensors with each other. Thus, several house controllers can receive registrations from one outside temperature sensor.

DOL 43X can share:

- Outside temperature sensor
- Outside humidity sensor
- Weather station

Sharing requires:

- A cabled LAN between the controller providing the shared equipment and the controller also using it.
- A stable network.

If the management program FarmOnline Explorer is used on the farm, you can see in the menu Network information if there are warnings regarding stability.

Specifications for LAN network	
Speed	100 Mbps
Delay	Maximum 100 ms
Average delay	< 5 ms (status can be seen in FarmOnline Explorer Network Information)
Packet drop	< 1% (status can be seen in FarmOnline Explorer Network Information)

SKOV A/S • Hedelund 4 • Glyngøre • DK-7870 Roslev
Tel. +45 72 17 55 55 • www.skov.com • E-mail: skov@skov.dk

