

TACHPAK® 10 & 30 Digital Process Tachometer

Part Number Series
T77510 & T77530

CE
RoHS

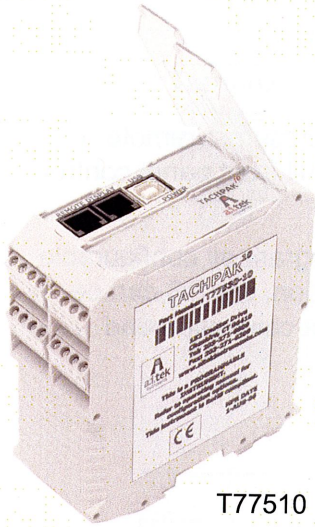

T77510

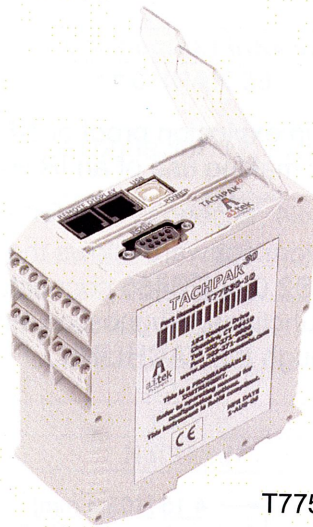

T77530

TACHPAK 30 Key Features (T77530):

- Wide range of AC or DC power (12-30 Vdc, 80-264Vac 50-60Hz)
- Greatly improved instrument accuracy, processing speed and response time.
- Frequency, period or counter modes.
- User-defined inputs for logic level, averaging, alarm set points and hysteresis,
- Signal normalization and math functions allow mathematical manipulation of input signals. Results can be displayed along with user-defined units.
- Accepts sinusoidal and square wave inputs as found in variable reluctance and digital output speed sensors.
- Accepts bi-directional sensor inputs and will decode quadrature or direction signal logic
- 2 solid state relays (fast response time) and 2 mechanical relays (high power)
- Analog output: 0-20mA, 4-20mA, -20-0-(+) 20mA (can be used with bi-directional sensor)
- Two programming methods: Front panel on display or USB2.0 connectivity to PC / Windows-based **TACHLINK**.
- Utility RS485 communication allows full **TACHLINK** function over longer distances (up to 8000 ft)
- Drives up to 8 remote displays (TACHTROL plus). A single display can be up to 1000 ft away with a simple RJ11 (phone jack) connection. Longer runs, cable type and number of displays will affect distance.
- Security mode protects unauthorized access for programming or alarm resets (through display or **TACHLINK**)
- Mounts to DIN rail. Power can be applied through special DIN bus when used with **AI-TEK** power supply.
- Environmentally hardened for temperature, vibration and shock. EMC / CE compliant to current BS/ EN directives.
- Designed and manufactured compliant with RoHS.

TACHPAK 10 Key Features (T77510):

- Same as TACHPAK 30 but excludes solid state relays, analog output and utility **RS485**

Programming Features:

Programming has been greatly simplified and can be accomplished by 2 different methods. Many configurable attributes have been added to improve flexibility and function.

- **TACHPAK** 10 and 30 can be programmed with the addition of a **TACHTROL plus** remote display. Programming is accomplished by navigating through a series of nested menus. In the

Programming Features (continued):

case of tachometer instruments embedded in explosion proof or **NEMA 4X** enclosures, remote access solves the problem of programming by making use of an IR link to allow full front panel control via a hand-held remote.

- **TACHLINK®**: PC / Windows-based custom software allows the user to program all configurable attributes of **TACHPAK** by PC via a USB2.0 or RS485 connection. In addition, the PC can be used to display data, perform security functions, diagnostics, analog output calibration and real-time data logging; all available through the **TACHLINK**.

Applications:

- Fast response overspeed shutdown
- Petrochemical production applications
- Pump or generator alarm
- Low speed switching
- Start-up, over/under speed switching
- Textile production applications
- Machine control
- Paper & pulp production
- Turbine speed control
- Food processing
- Conveyor alarms
- Printing industry
- Metal production
- Mining applications
- Test labs
- Generator set
- Broken or slipping belt drives

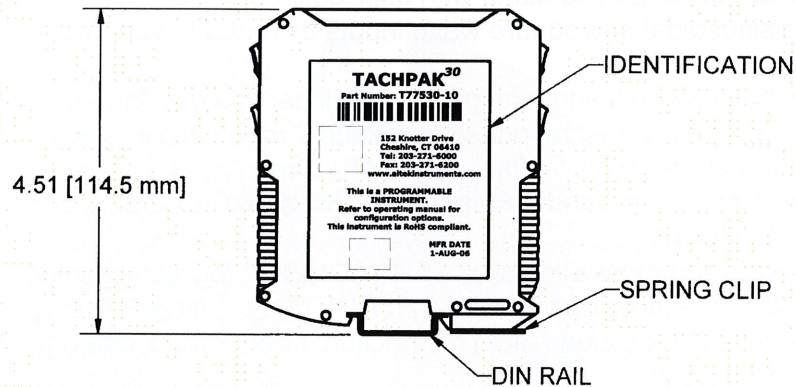
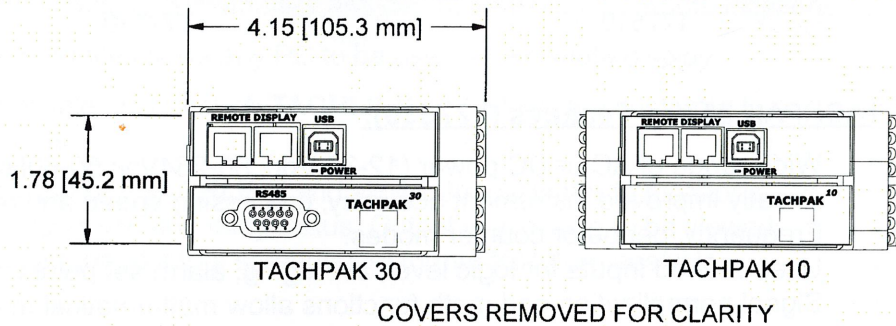

Ordering P/N	Input Power	Enclosure	Net Weight (lbs.)
T77510-10	80-264 Vac/12-30 Vdc	Standard	0.6
T77510-40	80-264 Vac/12-30 Vdc	NEMA 4X	3.4
T77510-70	80-264 Vac/12-30 Vdc	Explosion Proof	24.0
T77530-10	80-264 Vac/12-30 Vdc	Standard	0.7
T77530-40	80-264 Vac/12-30 Vdc	NEMA-4X	3.5
T77530-70	80-264 Vac/12-30 Vdc	Explosion Proof	24.0

Table 2: Connection Information			
Terminal Block	Pin #	TACHPAK 30	TACHPAK 10
Remote Display	Use RJ11 type connector. No individual breakout of pins.		
USB	Use USB "B" type connector. No individual breakout of pins.		
RS485 DB9	1,5	GND	Not Available
	2	Tx -	
	3	Rx -	
	6	Tx +	
	7	Rx +	
	4,8,9	Not Used	

Table 3: Connection Information			
Terminal Block	Pin #	TACHPAK 30	TACHPAK 10
TB1	1	Input Com	Input Com
	2	A Sig	A Sig
	3	B Sig	B Sig
	4	Direction Input	Direction Input
TB2	5	Verify -	Verify -
	6	Verify +	Verify +
	7	Reset -	Reset -
	8	Reset +	Reset +
TB4	9	Analog Out +	Not Available
	10	Analog Shield	
	11	Analog Out -	
	12	Not Used	
TB3	13	In GND	In GND
	14	12-30 Volt In	12-30 Volt In
	15	+12 Vdc Out	+12 Vdc Out
	16	Out GND	Out GND
TB5	17	Relay 1 Com	Relay 1 Com
	18	Relay 1 N.C.	Relay 1 N.C.
	19	Relay 1 N.O.	Relay 1 N.O.
	20	Not Used	Not Used
TB6	21	Relay 2 Com	Relay 2 Com
	22	Relay 2 N.C.	Relay 2 N.C.
	23	Relay 2 N.O.	Relay 2 N.O.
	24	Not Used	Not Used
TB8	25	AC/Earth Gnd	AC/Earth Gnd
	26	Not Used	Not Used
	27	AC Hot	AC Hot
	28	AC Neutral	AC Neutral
TB7	29	Digital 1 (no polarity)	Not Available
	30	Digital 1 (no polarity)	
	31	Digital 2 (no polarity)	
	32	Digital 2 (no polarity)	

Connection to 12-30 Volt In is also available on the bottom of **TACHPAK 10 & 30**. A special DIN rail power bus adapter is available as an accessory and works with the accessory power supply.

TACHPAK Enclosure Options

T77510-40 / T77530-40

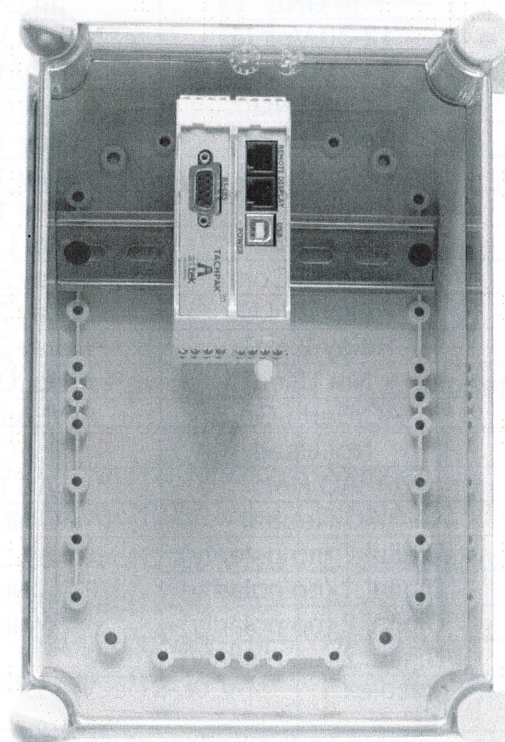
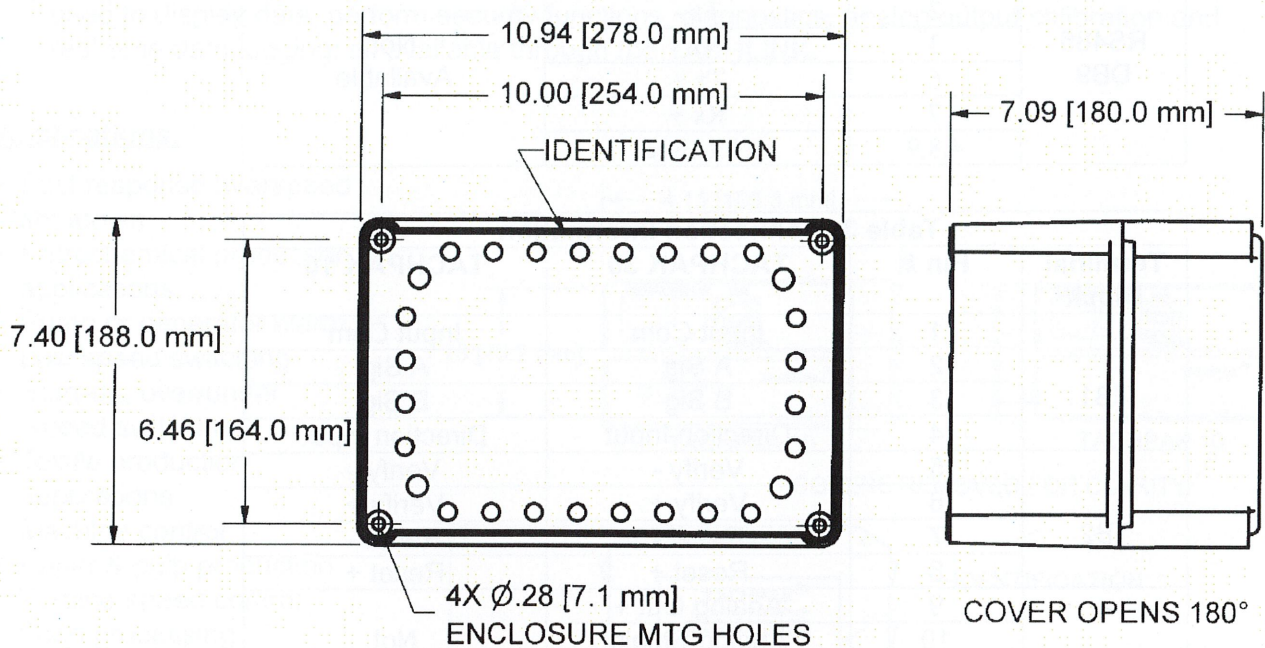

TACHPAK Enclosure Options

T77510-70 / T77530-70

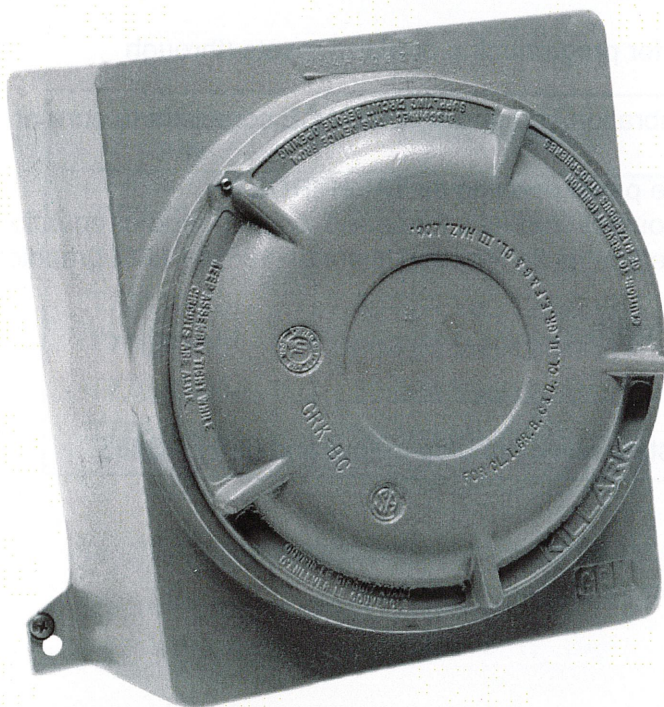
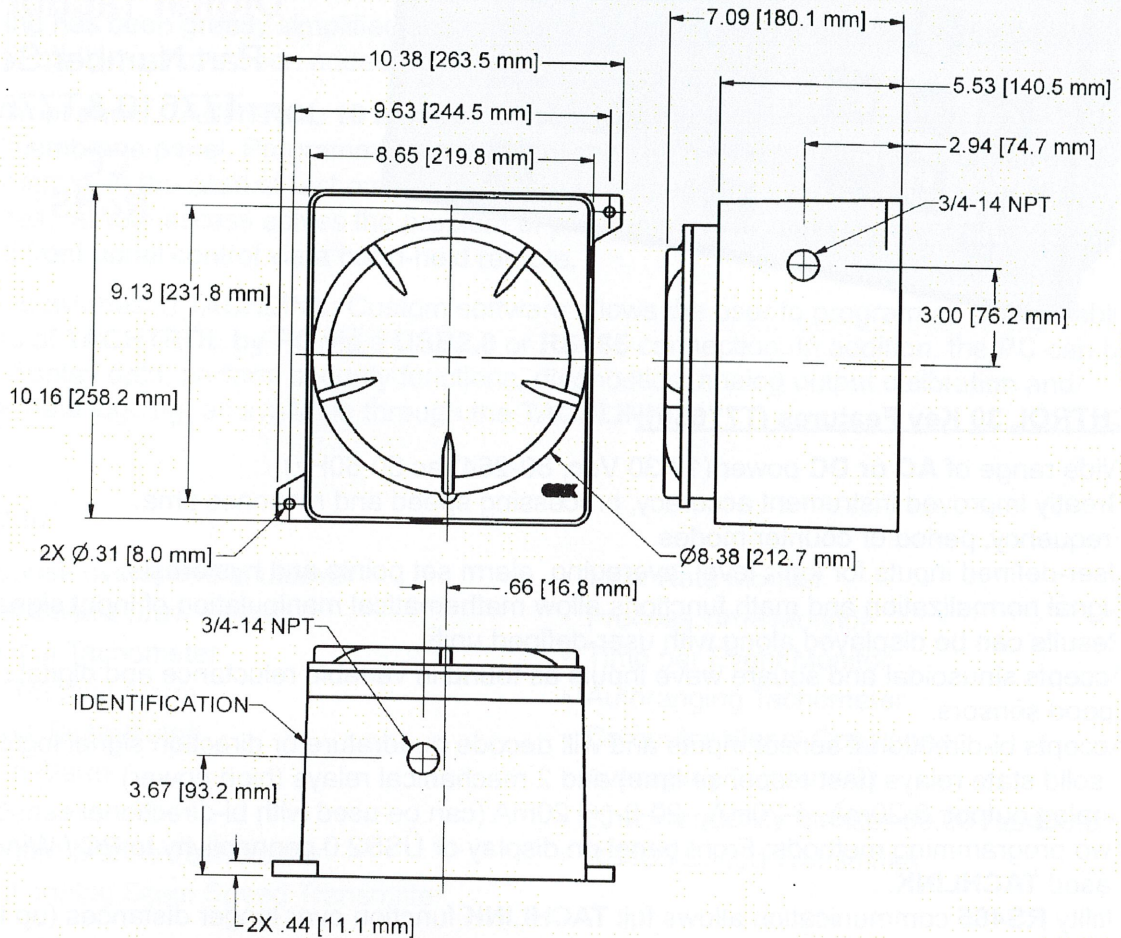

EXPLOSION PROOF

UL/CSA for hazardous locations
 Class I, Groups B, C & D;
 Class II, Groups E, F & G
 Class III
 also
 Class I, Zone 1, Groups IIB + H₂, IIA

ATEX
 0102 Ex II 2 G EEx d IIC
 For use in Zone 1,
 Group IIC, Category 2 G,
 IP66 hazardous locations

Certifications Inside Enclosure
 (Consult Factory for Latest Update)