

## 350 Series Pump with Brushless DC Motor

- Flow rates:- .3 mL/min to 2000 mL/min
- Flip up lid and sliding occlusion bed allows for fast and easy, tool free, tubing changes
- Transparent cover provides visibility of rotor movement
- Automatic tubing retention
- Accepts continuous tubing for clean fluid paths
- Side and bottom tubing entry ports for versatility
- Heavy-duty stainless-steel rotor
- Friction-reducing Nylatron® rollers



### Description

The 350 series is a laboratory-grade pump, driven by a long-lasting, brushless DC motor rated for continuous duty.

Pump flow rates can be regulated by input voltage (8-30VDC), or with the separate OEM controller, which provides 20:1 speed control, directional, and start/stop functions.

Combined with the ability to accept six tube sizes, this pump has an incredible range of flow rate capabilities.

350 series pumps are configurable to utilize 1.6mm (1/16") or high-performance 2.4mm (3/32") wall tubing giving them the ability to perform in a wide range of applications.

### Dimensions

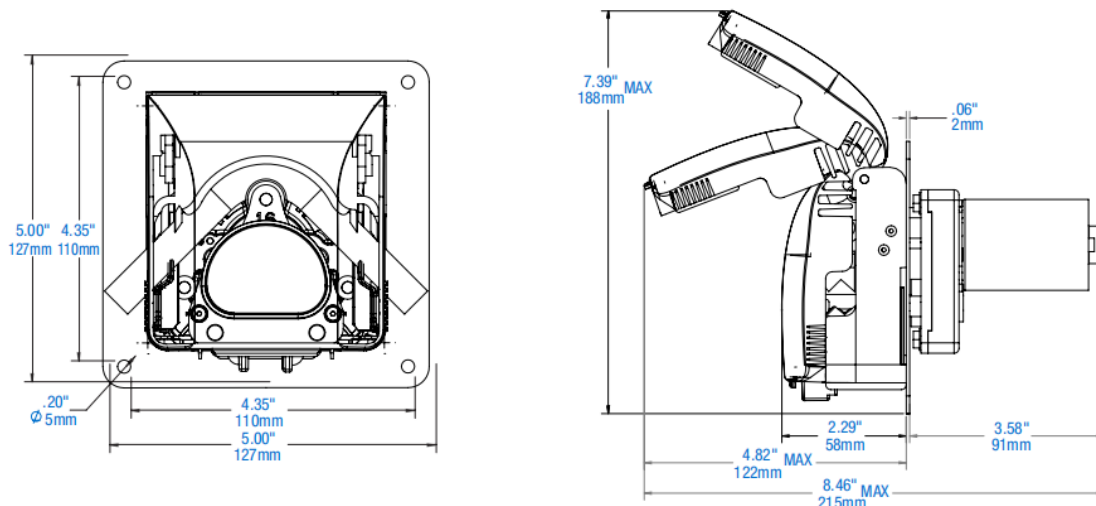

The Williamson Manufacturing Company Ltd provides no warranty on usage of pumps. We recommend that life tests be carried out prior to use. This information is given in good faith and believed to be correct at the time of publishing. The Williamson Manufacturing Company Ltd cannot accept responsibility for inaccuracy or any errors contained herein. Copyright the Williamson Manufacturing Company Ltd 2008.

**Williamson Manufacturing Co Ltd**  
**Unit 5, Lady Bee Industrial Estate**  
**Albion Street**  
**Southwick**  
**West Sussex BN42 4EP UK**  
**Email: [sales@williamsonpumps.co.uk](mailto:sales@williamsonpumps.co.uk)**

# 350 Series Pump with Brushless DC Motor

Devise your product code by using codes from the table on the right where stated below

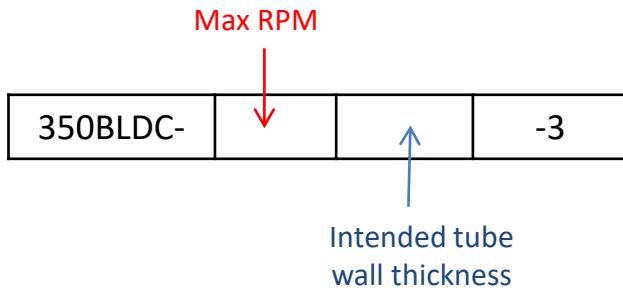

	Product code
<b>Maximum motor speed (rpm)</b>	
375 @ 24v DC (125 @ 8v DC)	375
125 @ 24v DC (41 @ 8v DC)	125
78 @ 24v DC (26 @ 8v DC)	78
17 @ 24v DC (5.5 @ 8v DC)	17
<b>Intended tube wall thickness</b>	
1.6mm (1/16")	016
2.4mm (3/32")	024

350-125-016-3 is an example product code for a 350 series brushless DC motor pump with a maximum speed of 125 rpm, for 1.6mm wall thickness tube with 3 rollers.

## Specification

## Materials of Construction

Maximum tube bore size	1.6mm wall = 8mm Bore 2.4mm wall = 6.4mm Bore
Motor type	Brushless DC.
Operating voltage	8 to 30v DC.
Maximum current	2A
Duty cycle	Continuous
Maximum Outlet pressure	25 PSI

Pump Head	Polycarbonate & IXEF
Roller Material	Nylatron
Rotor Material	SS
Ball Bearings	SS Sealed

## Flow Rates

Tube Bore Dia	8mm	6mm	5mm	3mm	1.6mm	0.8mm
mL per revolution	5.4	3.8	2.3	1.1	0.27	0.06

Flow rates are approximate and will be effected by tube material, tolerances, fluid viscosity & back pressure.

## Optional extras.

350 series Oem brushless motor control pcb complete with motor wiring harness & speed control potentiometer.  
Capable of 20:1 speed control with 0-5v DC input. Direction control via contact closure.  
Start/Stop via contact closure. See separate data sheet for information



The Williamson Manufacturing Company Ltd provides no warranty on usage of pumps. We recommend that life tests be carried out prior to use. This information is given in good faith and believed to be correct at the time of publishing. The Williamson Manufacturing Company Ltd cannot accept responsibility for inaccuracy or any errors contained herein. Copyright the Williamson Manufacturing Company Ltd 2008.

**Williamson Manufacturing Co Ltd**  
**Unit 5, Lady Bee Industrial Estate**  
**Albion Street**  
**Southwick**  
**West Sussex BN42 4EP UK**  
**Email: [sales@williamsonpumps.co.uk](mailto:sales@williamsonpumps.co.uk)**