

## 400 series pump with induction motor

**Williamson**  
UK manufacturers of quality peristaltic pumps

- Robust
- Reliable
- Low cost
- Capable of continuous running
- Various Tube Materials/Sizes



The 400 series industrial range of peristaltic pumps has been designed to offer a low cost, robust method of dosing a wide range of liquids and offers flow rates of 0.5 – 4 litres per minute, depending on the choice of tube material / size and gearmotor RPM.

As with all peristaltic pumps they offer excellent suction performance with the ability to self prime up to 5 metres, even when priming from dry. Peristaltic pumps offer a good level of accuracy and repeatability and as only the tube contacts the pumped media, they are corrosion resistant, extremely reliable, easy to clean and inexpensive to maintain. The 400 series is suitable for continuous duty industrial pumping applications. Available as 230v fixed speed or 230v variable speed (115v available on request) with speed controller for variable speed outputs. The induction motors are available with speeds of 30, 50, 100 and 125 rpm.

Please note the 10mm tube delivers 18ml per RPM and 13mm tube delivers 33ml per RPM. To calculate the flow multiply the RPM of gear motor by the displacement per RPM. These flow rates are based on silicone tube pumping water. Santoprene tube will be approx. 10% less. All flow rates are approximate and are effected by manufacturing tolerances, fluid viscosity, back pressure & tube age.

The Williamson Manufacturing Company Ltd provides no warranty on usage of pumps. We recommend that life tests be carried out prior to use. This information is given in good faith and believed to be correct at the time of publishing. The Williamson Manufacturing Company Ltd cannot accept responsibility for inaccuracy or any errors contained herein. Copyright the Williamson Manufacturing Company Ltd 2008.

**Williamson Manufacturing Co Ltd**  
**Unit 5, Lady Bee Industrial Estate**  
**Albion Street South wick**  
**West Sussex**  
**BN42 4EP UK**  
Email: [sales@williamsonpumps.co.uk](mailto:sales@williamsonpumps.co.uk)

# 400 series pump with induction motor



Devise your product code by using codes from the table on the right where stated below.

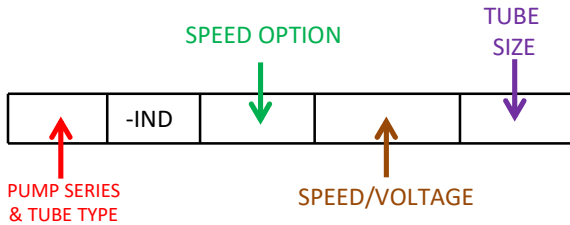

**401-IND-F-030-230-100**  
 Example product code for a 400 series pump fitted with Santoprene tubing, fixed speed, 30 pm 230v AC 10mm ID tube

	Product Code
<b>Pump Series and Tube Material</b>	
Silicone	400
Santoprene	401
<b>Speed Option</b>	
Fixed	-F
Variable	-V
<b>Speed &amp; AC Voltage</b>	
30 rpm 230v	-030-230
50 rpm 230v	-050-230
100 rpm 230v	-100-230
125 rpm 230v	-125-230
<b>Tube Size (bore) mm</b>	
10	-016
13	-030

As standard the pump is fitted with a fixed position roller assembly. Alternatively the pump can be fitted with a sprung roller assembly by appending part number with /S

## Dimensions

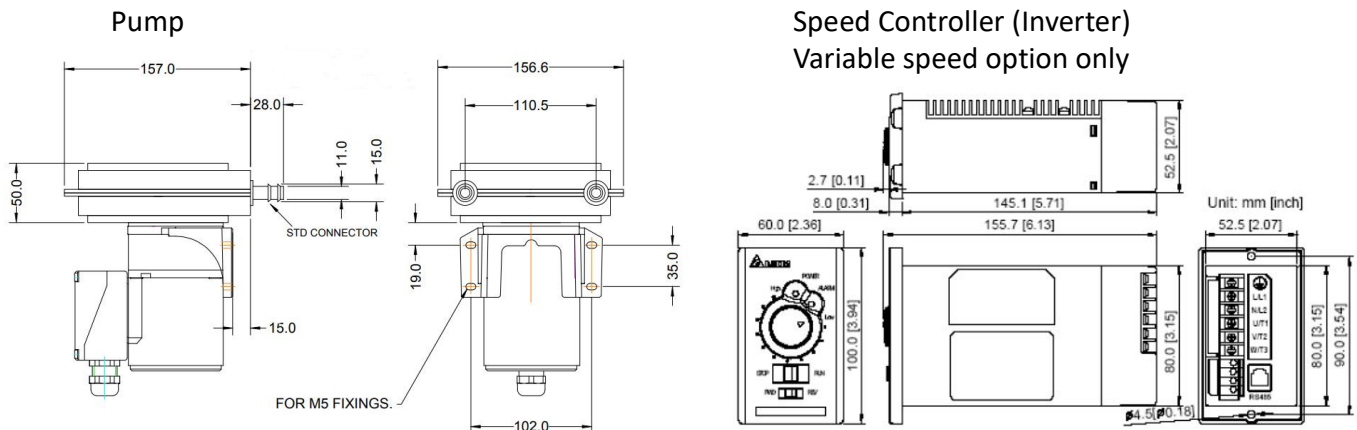

The Williamson Manufacturing Company Ltd provides no warranty on usage of pumps. We recommend that life tests be carried out prior to use. This information is given in good faith and believed to be correct at the time of publishing. The Williamson Manufacturing Company Ltd cannot accept responsibility for inaccuracy or any errors contained herein. Copyright the Williamson Manufacturing Company Ltd 2008.

**Williamson Manufacturing Co Ltd**  
 Unit 5, Lady Bee Industrial Estate  
 Albion Street South wick  
 West Sussex  
 BN42 4EP UK  
 Email: [sales@williamsonpumps.co.uk](mailto:sales@williamsonpumps.co.uk)