

1 INTRODUCTION

The GAC 335 Series is a universal, 2.9 lb-ft (3.93 N-m), 65 ° max rotation actuator with fast response, low current draw, and precision bearings. When paired with the ESD5330 or ESD5340 speed controllers

The 335 Series includes:

- 3.3 lbf-ft [4.5 N·m] Net Torque
- 65 ° Rotation
- Single-Sided Shaft
- 24 V DC
- ADB335-24 includes the Military-Style Connector without Mating Connector
- ADB335F-24 includes a position feedback sensor (Novotechnik) and is compatible with ESD5330/5340
- Provides rapid response to transient conditions
- Return spring preload is factory set to a lift-off torque of 9 to 12 in-lbs



ADB335-24

Military Style
Connector

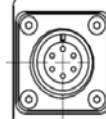

On Unit



ADB335F-24

Feedback Sensor
Connector

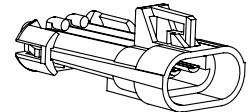

2 SPECIFICATIONS

PERFORMANCE	
Maximum Rotation	65° ± 1°
Available Torque	2.9 lb-ft [3.93 N-m]
Response Time	10 % to 90 % Travel < 100 ms
ELECTRICAL CHARACTERISTICS	
Operating Voltage	24 V DC
Normal Operating Current	6.0 A at 24 V DC
Maximum Current	9.0 A at 24 V DC
Coil Resistance (Terminals A to D 24VDC)	2.5 Ω
Coil to Housing	∞
RELIABILITY	
Vibration	4g, 25 to 100 Hz
Shock	MIL-STD-202
Testing	100% Functionality Tested
Rated Life	>40 Million Cycles

LEVER	
Shaft	SAEJ1300 Actuator GAC Serrated Shaft Levers
ENVIRONMENT	
Ambient Temperature	-40 to 257 °F [-40 to 125°C]
Relative Humidity	MIL-STD-810F
Salt Spray	ASTMB117-97
All Surface Finished	Fungus & Corrosion Resistant
AGENCY	
CE	Compliant
PHYSICAL	
Dimensions	See Section 3
Weight (approx.)	13.2 lbf [5.99 kgf]
CONNECTORS & HARNESSES	
Mating Connector (Military-style)	EC1000 (Straight) EC1010 (90 °)
Cable Harness (Military-style)	CH1203 CH1210
Feedback Position Sensor Connector	EC1523 (Delphi Metri Pack 150)

3 DIMENSIONS

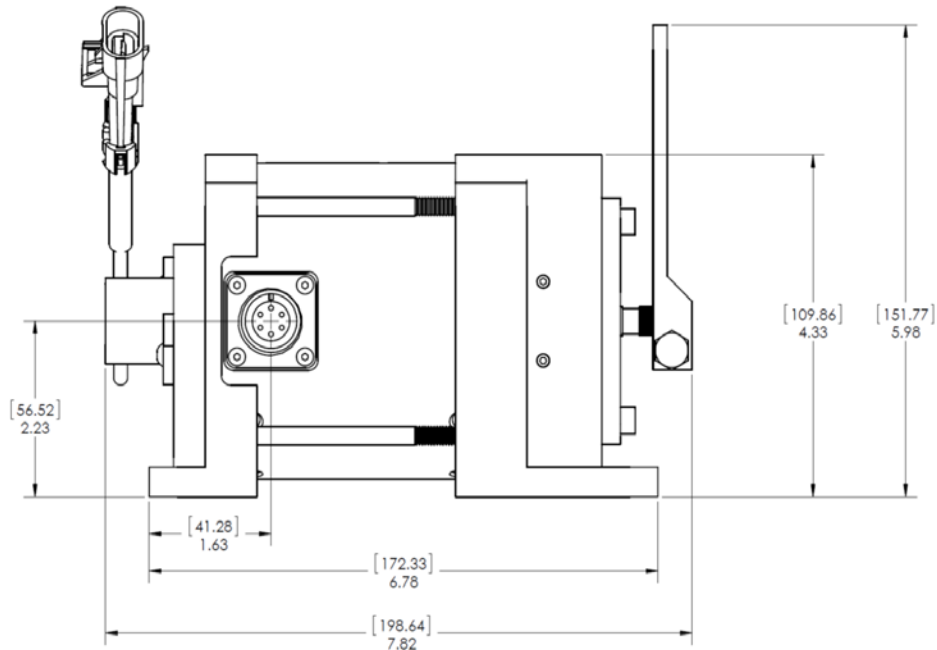

Dimensions [mm]
in

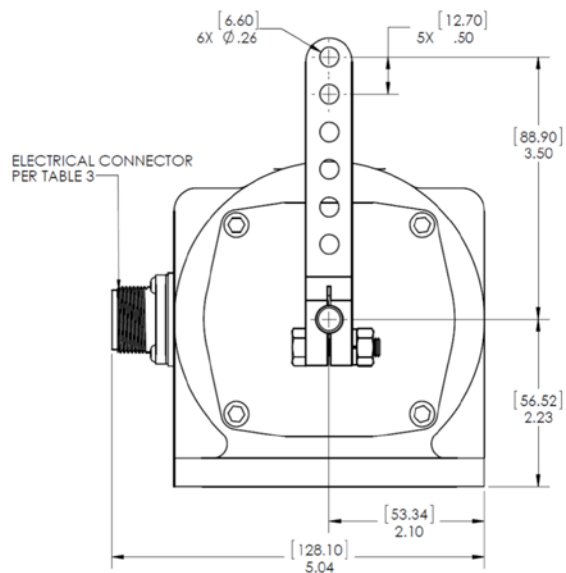
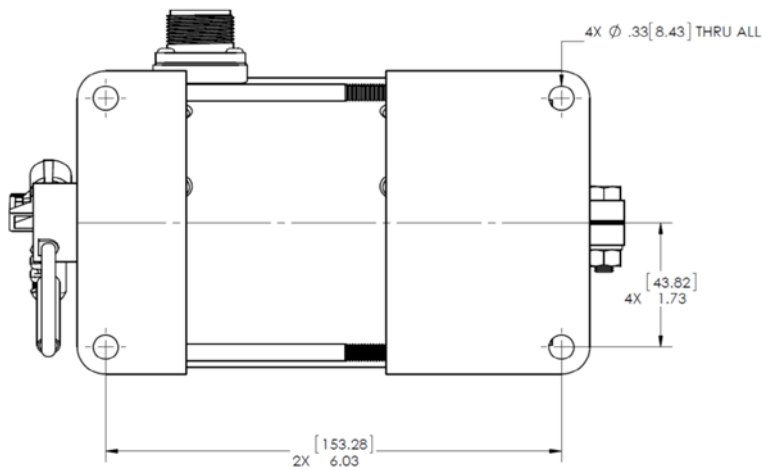

Vertical orientation allows for the draining of fluids in moist environments.



Mount in a cabinet, sealed metal box, or directly to the engine.



Avoid Extreme Heat

The optional SR128 Vibration Dampeners can be used to mount actuator. These mushroom mount dampeners add additional dimensioning as shown in this figure.

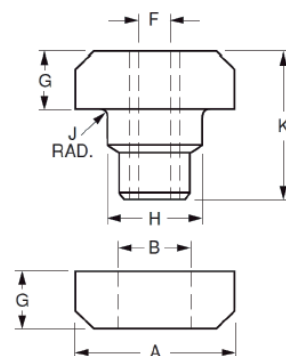

SR128 Vibration Dampeners

4 INSTALLATION



An overspeed shutdown device, independent of the governor system, must be provided to prevent loss of engine control which may cause personal injury or equipment damage. Do not rely exclusively on the governor system to prevent overspeed. A secondary shutoff device such as a fuel solenoid must be used.

- The actuator must be rigidly mounted as close as possible to the fuel control or throttle body control lever of the engine. Vibration from the engine will not affect the operation of the actuator. The preferred mounting is with the electrical connector facing to the side or downward.
- Linkage arrangement of any actuator system is always important. High quality rod end bearings should be used. Rod end bearings that have high friction can cause instability and require servicing.
- Levers and linkage should be sturdy yet low in mass for the fastest speed of response.
- Optional SR128 Vibration Dampeners can be used to mount actuator

Determine the optimal arrangement of the linkage for actuation of the engine fuel control.

- For proportional actuators to operate with linear control systems, it is important to obtain a linear relationship between actuator stroke and fuel delivery.
- In general, the linkage should be adjusted so that the fuel control lever minimum and maximum fuel stops are used rather than the actuator internal mechanical stops. The actuator should be adjusted so that it operates over at least one half (32.5 degrees) of its available travel.
- The linkage configuration for gaseous systems is illustrated in Figure 1. The lever on the actuator should be nearly parallel to the throttle body lever at the mid fuel position for linear fuel control.
- Figure 2 shows the full fuel position for linear fuel control.

FIGURE 1 FUEL LEVER AT MID FUEL/AIR POSITION



FIGURE 2 FUEL LEVER AT FULL FUEL/AIR POSITION

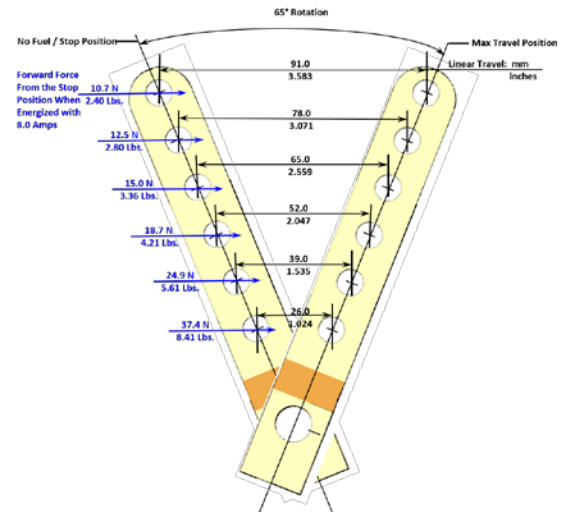

INSTALLATION PROCEDURE

1. Position the actuator to ensure minimal misalignment between each end of the governor system linkage.
2. Adjust the linkage so that the fuel control lever minimum and maximum fuel stops are used rather than the actuator internal mechanical stops.
3. Adjust the actuator so that it operates over at least one half (32.5°) of its available travel (65°).
4. Attach the Actuator to the selected location on the engine.
5. Adjust and secure the Linkage Rod and Ball Bearing Rod Ends to the Actuator Lever and Fuel Control Levers.

For proportional actuators to operate with linear control systems it is important to obtain a linear relationship between actuator stroke and fuel delivery.

5 WIRING

The mating electrical connector must be wired in a configuration dependent on the system voltage supply.

The maximum wire size that will fit into the actuator mating half connector is 16 AWG [1.3 mm²]. Connectors and pre wired cable harnesses are available as noted in this table.

Since the 335 is a proportional actuator, the connector to speed control does not have polarity.

AVAILABLE CONNECTORS and HARNESES

CH1203	MIL Cable Harness - 12 ft [3.66 m] - straight
CH1210	MIL Cable Harness - 12 ft [3.66 m] - 90°
EC1000	MIL connector - straight
EC1010	MIL connector - 90°

NOTE

Actuator cable harnesses with lengths greater than 10 ft. [3 m] from the actuator to the speed control unit may introduce current losses which can restrict full rotation of the actuator. In this case, use of a larger gauge wire is required.

For applications where EMI is of concern, twisted, shielded cable for the actuator is recommended. Twisting of the cable alone will substantially reduce EMI.

24 V DC APPLICATIONS

For 24 V DC applications the maximum current is 9.0 A. The recommended wire size is at least 16 AWG [1.0 mm²].

24 V DC OPERATION

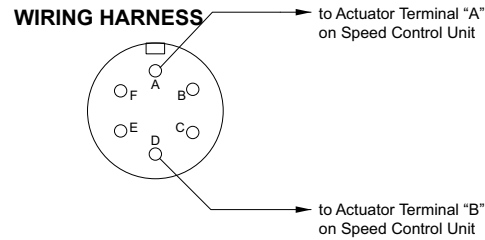

FEEDBACK UNITS

The ADB335F version of the actuator includes a position sensor. The feedback sensor units, ADB335F-24, can be used for position indication to specific GAC controls or other devices.

Position Feedback Sensor Mating Connector EC1523

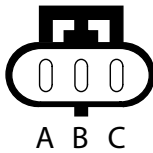

HARNESS	
PIN	SIGNAL
A	+5V
B	GND
C	OUT

Position Feedback Sensor Output

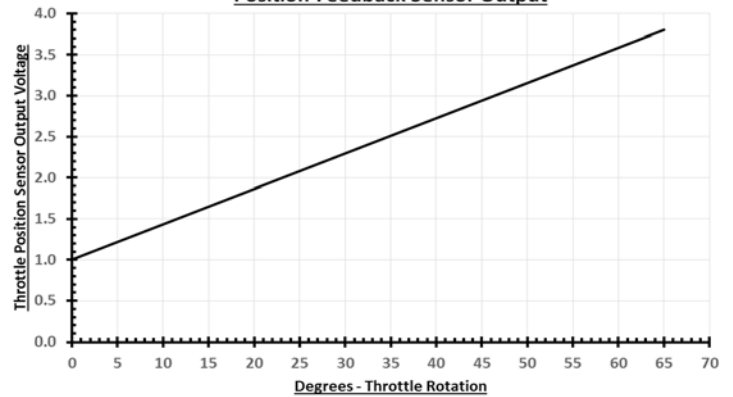

6 ADJUSTMENTS

Confirm the following and make adjustments once installation is complete and before starting the engine.

1. Confirm the linkage is not binding and that friction is minimal.
2. Push the actuator to the full fuel or air position and release. It should return instantly to the zero fuel/air position without any binding.
3. Once the engine has been started, the linkage can be optimized.
4. Smaller angles of actuator travel may improve transient performance, but will reduce available force at the fuel control lever.
5. Allow the actuator to operate through at least one half (32.5 degrees) of its stroke will usually provide near optimum response.

7

ALTERING ACTUATOR LEVER POSITION - FORCE AND LINEAR TRAVEL

The effective actuator force can be increased from the factory settings by adjusting the spring adjustment plate in the actuator. The actuator return spring preload is factory set to a lift-off torque of 9 to 12 in-lbs.

Decreasing this preload, by rotating the spring adjusting plate clockwise, will increase the effective actuator force and decrease response time in the full fuel direction, but will increase response time in the no fuel direction.

To adjust the spring adjustment plate:

1. Remove the lever. Remove the four socket head cap screws holding the end cover in place and set aside.
2. Remove the cover, leaving the seal in place.
3. Using a cross tip screwdriver gently loosen but do not remove the three screws holding the adjustment plate.
4. Rotate the plate clockwise to increase force.
5. Using a torque driver, being careful not to over tighten torque the screws to 20-25 in-lbs [27.1-33.9 N m]. Ensure the washers are centered in place.
6. Replace the cover with seal and hand tighten the four socket head screws. Using care not to over tighten torque the screws in opposite order to 33-35 in-lbs [44.8-47.5 N m]

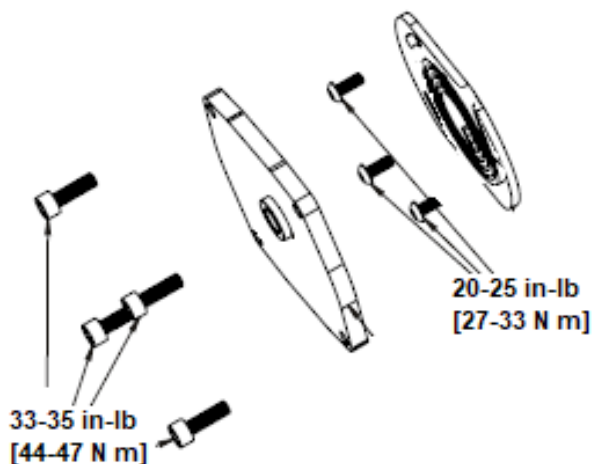
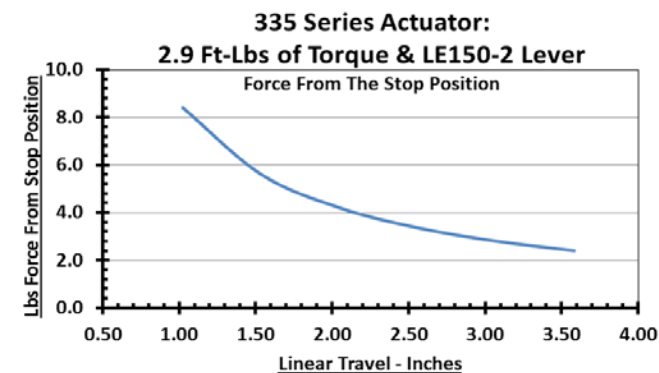
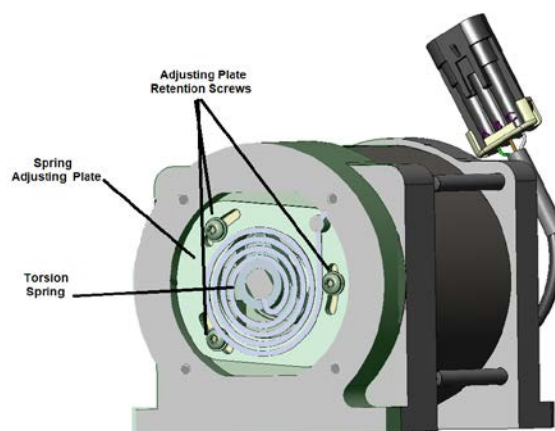
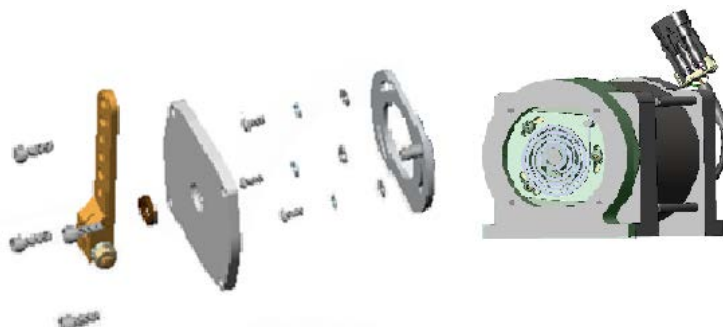

8

TROUBLESHOOTING

If the governor system fails to operate, test the following at the actuator mounted connector while moving the actuator through its stroke.

1. Energize the actuator to full fuel (follow steps in your control unit publication)
2. Manually move the actuator through its range. No binding or sticking should occur.
3. If the actuator passes the tests, the problem is elsewhere in the system. Refer to the control unit troubleshooting publication.

TERMINALS	EXPECTED RESISTANCE
A to D	2.5 Ohms
A to Housing	∞
D to Housing	∞