

The VPR-SA sounder is available in two variants the SA2 and SA4. Both models can be supplied in either red or white housings making them ideal for both fire and security applications. The sounders are supplied with a two-stage alarm override which is activated by a third negative wire from the fire panel.

The SA2 version is designed for applications where low current consumption relative to sound output is a consideration. An extremely low 11mA @ 100.3dB(A) is achieved.

The SA4 version has been designed for maximum sound output and achieves a healthy 105.3dB(A) making it ideal for a wide range of applications including general industrial, security and fire, making this a true multi purpose high output sounder.

Each sounder is supplied with its own mounting base which comes with marker points for drilling industry standard M20 PG gland entries to maintain the products IP integrity. Cables can be entered from the rear or side for surface and flush wiring options.

- 4 tones
- standard and hi-output versions available
- continuously variable volume control
- designed to work with both conventional and two-wire (SAV-WIRE®) systems
- IP65 specification for both SA2 and SA4 variants
- features back locking system as standard



TECHNICAL





voltage range (Vdc)	8 - 35
number of tones	4
operating frequency (Hz)	800 - 1000
temperature range (°C)	-20 to +70
monitoring	reverse polarity
protection rating	IP65
boxed weight (kg)	0.20
body colours available	red or white (ABS fire retardant plastic)

PERFORMANCE

version	SA2	SA4
sound output, typical (dBA)	100.3	105.3
sound output, anechoic chamber (dBA)	99.5	104.6
sound output, reverberation chamber (dBA)	116.3	120.0
max. current consumption @ 24Vdc (mA)	11.0	36.2
power consumption @ 24Vdc (mW)	264	869

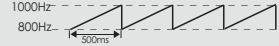
NB: see tone list performance for more accurate current consumption figures

TONE LIST - GRAPHICAL & PERFORMANCE

tone	description	typical sound output (dBA)		max running current (mA)		waveform diagram
		SA2	SA4	SA2	SA4	
version		SA2	SA4	SA2	SA4	
sweep	800-1000Hz swept every 500ms (2Hz)	99.5	104.6	9.7	33.2	
pips	800Hz for 800ms, then off for 500ms	98.7	102.6	9.4	31.6	
warble	800Hz for 500ms, then 1000Hz for 500ms	99.9	103.7	10.0	32.6	
continuous	800Hz continuous	99.2	103.2	11.0	36.2	

ORDERING INFORMATION

red body, 4 tone, Sa2	VPR-SA2-R
red body, 4 tone, SA4	VPR-SA4-R
white body, 4 tone, SA2	VPR-SA2-W
white body, 4 tone, SA4	VPR-SA4-W

DIMENSIONS, PRODUCT MOUNTING & CABLE ENTRY

all measurements are in mm

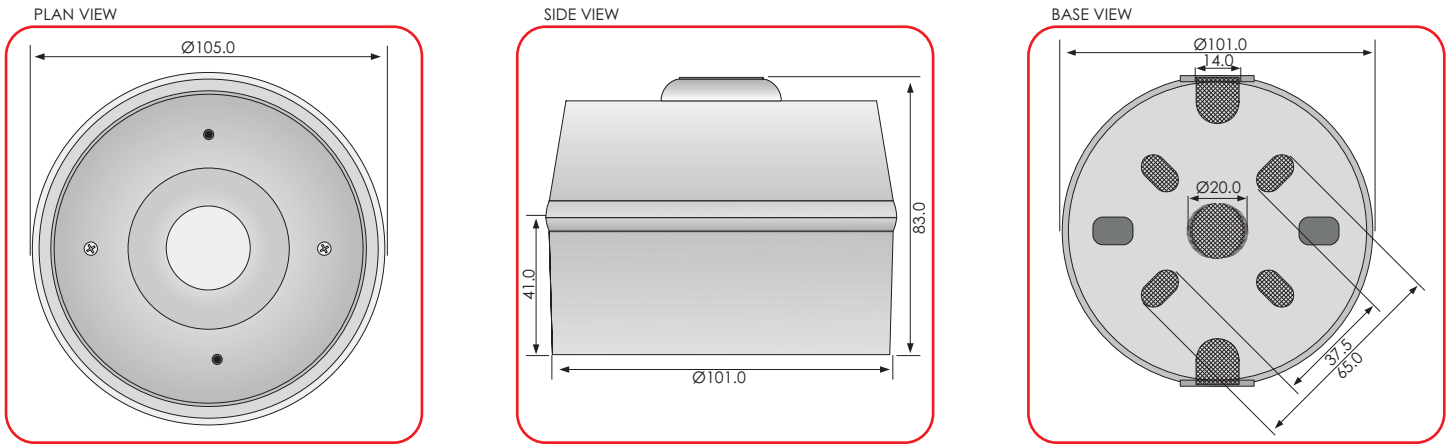

WIRING CONFIGURATION

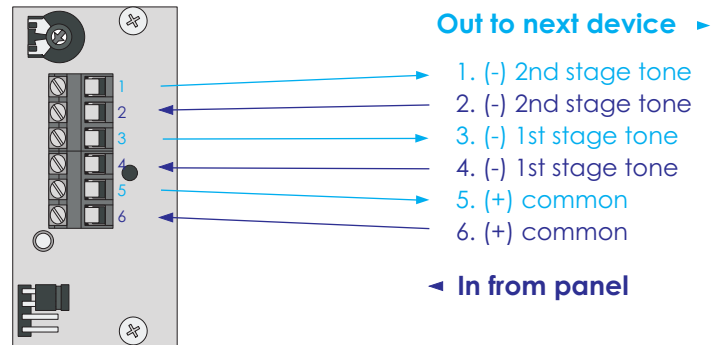

STONE & VOLUME SELECTION

