

DAK (Manifold Valve) Gate Valve Replacement Solution



Gate Valve Replacement Solution

To ensure that large steam boilers are physically balanced and not subject to undue forces, the steam outlet piping is usually taken from both sides of the boiler. It is then brought together in a manifold to a central main steam line to the steam turbine.

The pipes from the boiler are also usually equipped with manual gate valves which can be closed for pressure testing and maintenance.

The DAK valve replaces these gate valves and the manifold to integrate all those functions in one single valve. This design improve the steam flow, reducing the pressure drop and thus improving the overall efficiency of the plant.



We combine our decades of experience, expertise and, knowledge to satisfy the demands that our customers place on us

Key features

- > Simple operation
- > Monolithic body design to avoid weld joints
- > Excellent streamlining to reduce pressure drop across the valve and increase plant efficiency
- > Modular design of the valve to meet customer specifications and requirements
- > Inlet, outlet, and bypass connections to match the dimensions and material of the pipework

Benefits

- > The DAK valve is designed to join the two main steam lines exiting the boiler and, if required, to isolate the boiler from the piping. The valve is designed to take the two steam lines from the boiler and centralise the flow into a single pipe exiting the valve.
- > The valve internal design is precisely machined to ensure maximum flow efficiency and to reduce the pressure drop across the valve, ensuring maximum efficiency of the entire plant
- > Because of its installation in the main steam system, the body is machined from forged alloy material to ensure long life under exposure to the extreme temperatures and pressures found in critical power plants
- > The valve seat is integrated in the body and hard faced for added durability and a long, problem free life
- > Quick-changeable seat design is available to reduce maintenance time during overhaul or shutdowns

Application

- > The DAK valve replaces the gate valves and the connecting manifold that are installed in the initial run of the boiler superheater outlet piping to the main steam piping and to the steam turbine.
- > The DAK valve can be shut off (manually or with an actuator) to conduct maintenance and/or pressure testing
- > The valve has three weld seams into the boiler outlet piping, as opposed to seven weld seams if the gate valves and a manifold are installed. This saves time and reduces costs during the piping erection

Technical details

Body style
2 inlets and 1 outlet, Y-shaped body

Seat
Hard faced seat

Codes
AD 2000, TRD, IBR, manufactured to ASME

Operating limits
Temperature up to 650°C
Inlet pressures up to 350 bar[a]

Bonnet
Self-sealing bonnet

Interfaces
Butt-weld ends according to the customer's specification

Actuator
Manual, electric or hydraulic

Product breakdown

Typical materials

Materials EN	ASTM
1.7383	SA 182 Gr. F22
1.4903	SA 182 Gr. F91
1.4901	SA 182 Gr. F92
Further materials on request	

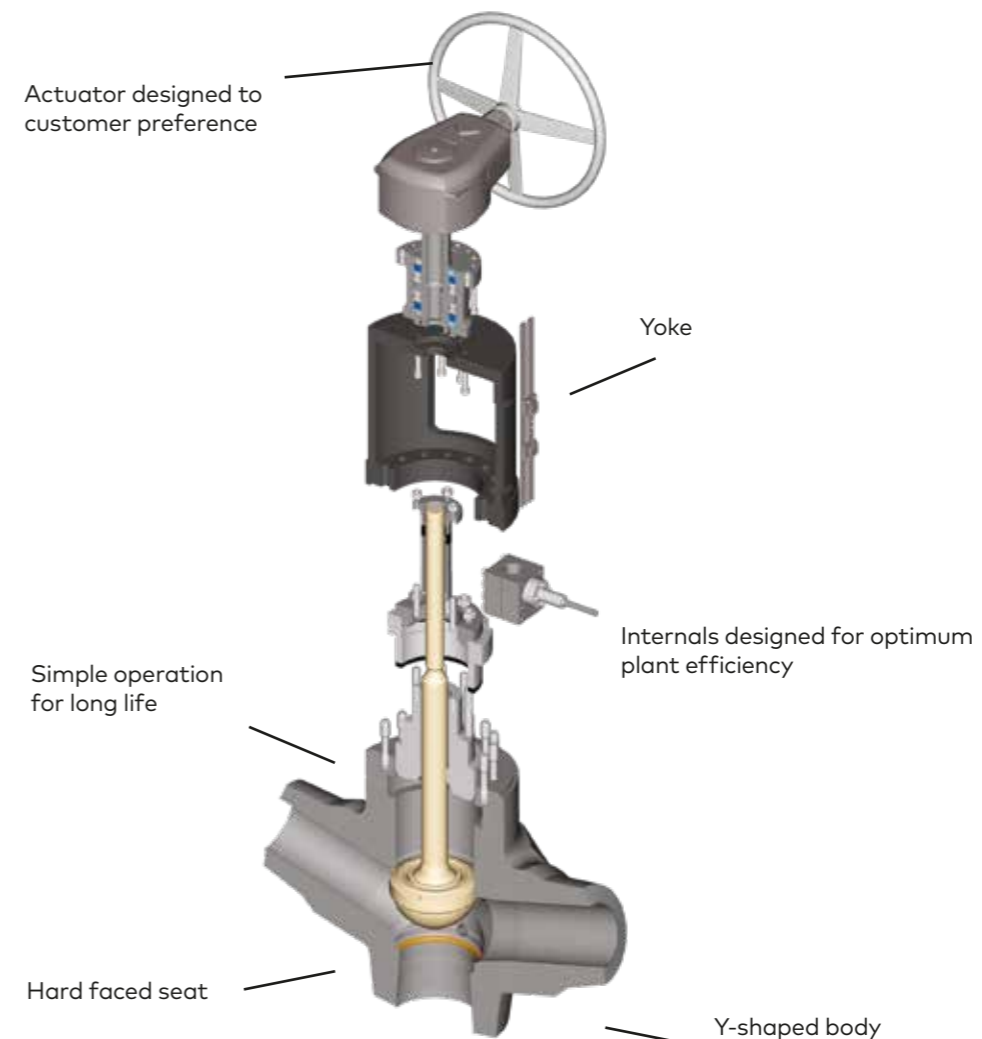
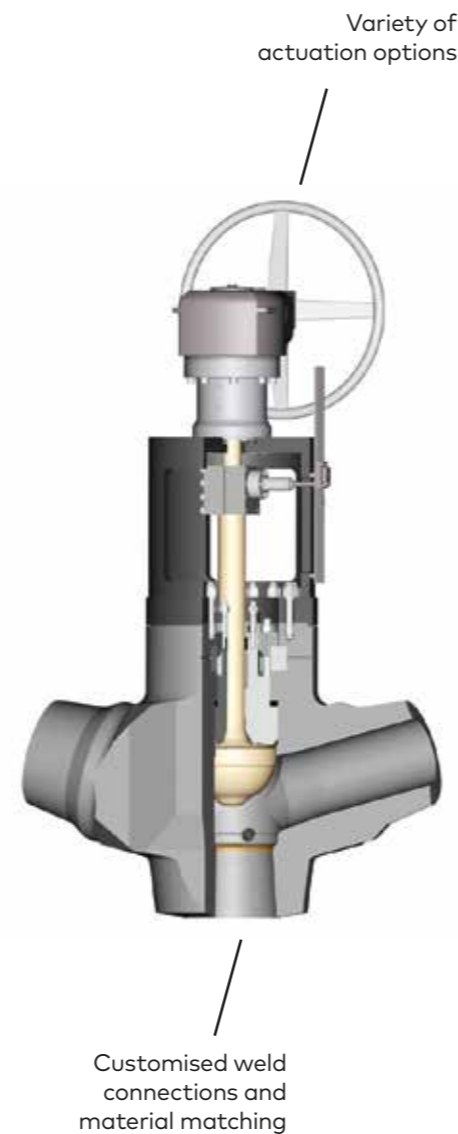

For more information, contact your local IMI Critical Engineering team.

IMI Bopp and Reuther

Carl-Reuther-Straße 1
68305 Mannheim
Germany

Tel: +49 (0) 621 76220 - 0
Fax: +49 (0) 621 76220 - 400

imibr.sales@imi-critical.com

IMI Critical Engineering

Lakeside, Solihull Parkway
Birmingham Business Park
Birmingham B37 7XZ
United Kingdom

Tel: +44 (0)121 717 3700
Fax: +44 (0)121 717 3701

www.imi-critical.com

Information in this document is protected by copyright. All rights are reserved.
Information in this document may be modified at any time without notice.