

# Electro pneumatic mass-flow servo valve

## Model PVM 064/065

Single stage industrial type

### PVM 064



Sub plate mounting construction according to DIN ISO 55 99 NG2  
Attention: The holes for mounting screw M5 do not correspond to DIN ISO (see drawing).

### PVM 065

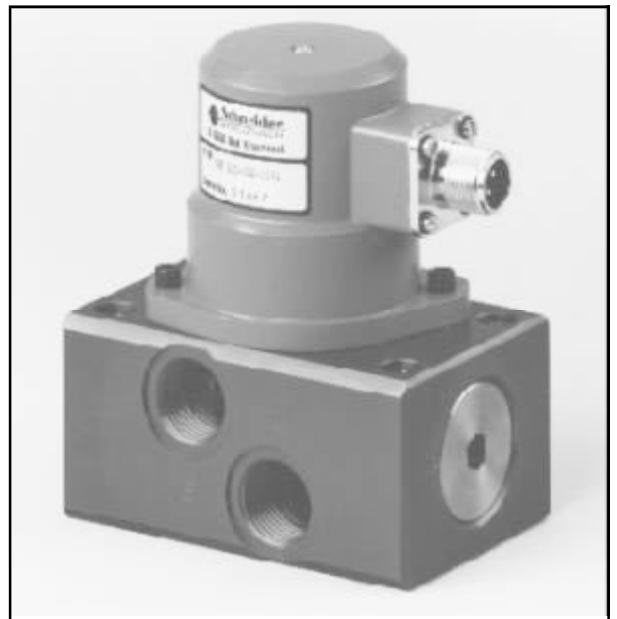

pipe connection R 1/2" construction

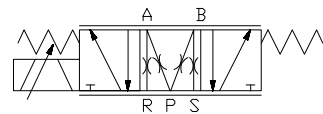

symbol :

#### SPECIAL FEATURES :

- high reliability
- easy service
- robust construction, can be field serviced
- high dynamic response, irrespective of air pressure
- linear and non-linear flow characteristics available
- highest quality standard
- no jet pipes or nozzles
- sliding spool only, no pilot stage
- easy zero adjustment

#### GENERAL DESCRIPTION :

Type	: electrical input stage, symmetrical torque motor
Pilot stage	: none !
Main stage	: directly controlled sliding spool, 5/3 way version
Style of mounting	: PVM 064 sub-plate, PVM 065 pipe-line connection
Mounting position	: unrestricted
Weight	: 1,4 kg

## Technical data PVM 064/065

### 1. Pneumatic data (Definition according to VDMA 24311)

.1	nominal pressure	$p_N$	= 6 bar
.2	operating pressure	$p$	= 0-6 bar
.3	max. pressure ( static test pressure )	$p_{max}$	= 10 bar
.4	nominal flow ( at $p_N = 6$ bar and $\Delta p = 1$ bar )	$Q_N$	= max. 1300 l/min = 80Nm <sup>3</sup> /h
.5	quiescent flow	$Q_{02}$	≤ ca. 5% $Q_N$
.6	hysteresis	$H$	≤ 4,0% $i_N$ (with dither)
.7	threshold sensitivity	$E$	≤ 0,2% $i_N$ (with dither)
.8	threshold span	$S$	≤ 5% $i_N$ (with dither)
.9	linearity deviation		≤ 10% $i_N$
.10	flow symmetry $-Q_N$ to $+Q_N$		≤ 10% $i_N$
.11	pressure gain	$V$	= 0,2% $p_b$ / 1% $i_N$
.12	overlap, standard	$h$	= pneumatic null
.13	operating temperature range	$\delta_m$	= 253 . . . 353 K
.14	temperature shift		= 0,5% for = 50K
.15	filtration of air		< 10 $\mu$ m class 4 . . . 5 as per NAS 1638 or SAE-ASTM 1
.16	fluid		= air, without water inclusion, on oiled operation slightly greased with pneumatic oil 32 ( ESSO)
.17	step response time 0....100% $i_N$		= 8ms
.18	dither recommendation		= 5% $I_{NSS}$ / 50Hz

### 2. Electrical data

nominal voltage	rated current	coil resistance	nominal power	coil inductivity
12 V	+ - 400 mA	2,7 $\Omega$	5 W	228 mH
6 V	+ - 800 mA	7 $\Omega$	5 W	60 mH

# Characteristics:

flow signal function  $Q = f(i)$  at  $p_0 = 6\text{bar}$  and  $\Delta p = 1\text{bar}$

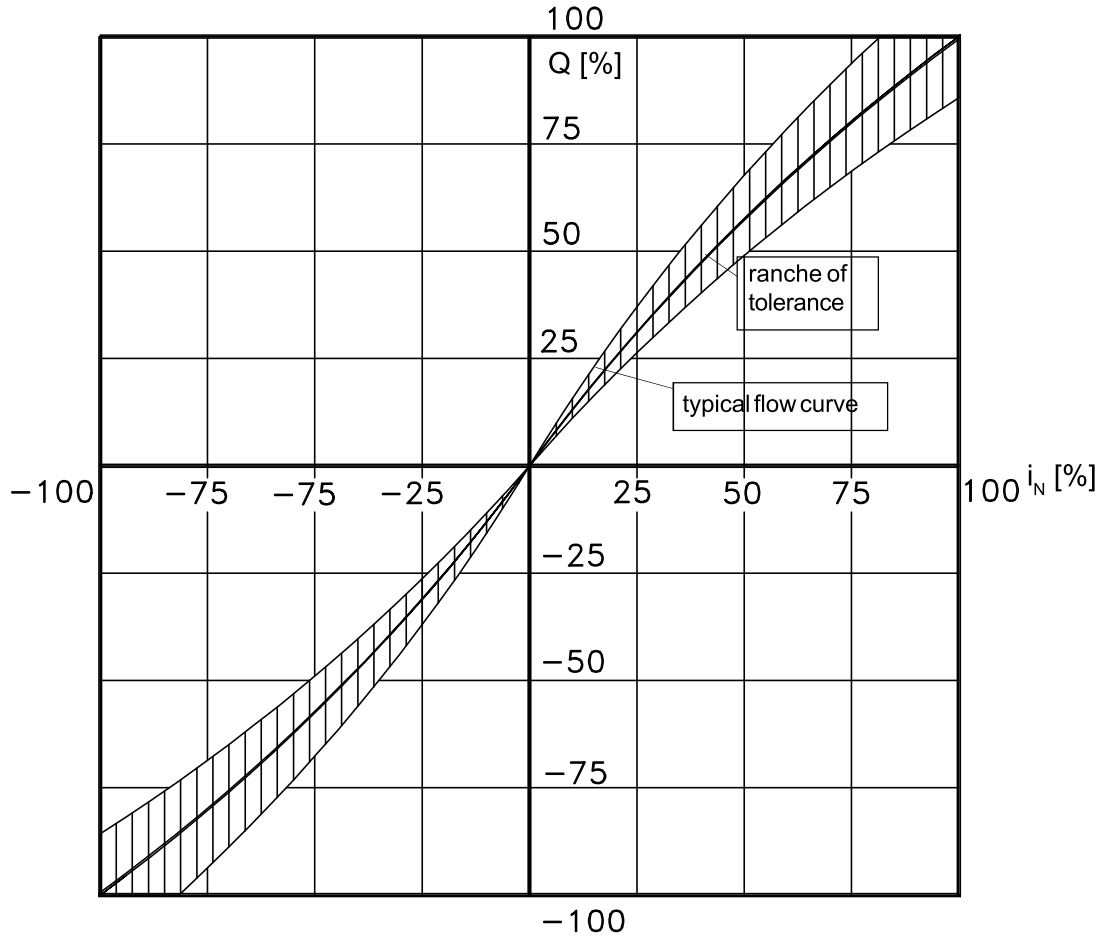

## frequency characteristic

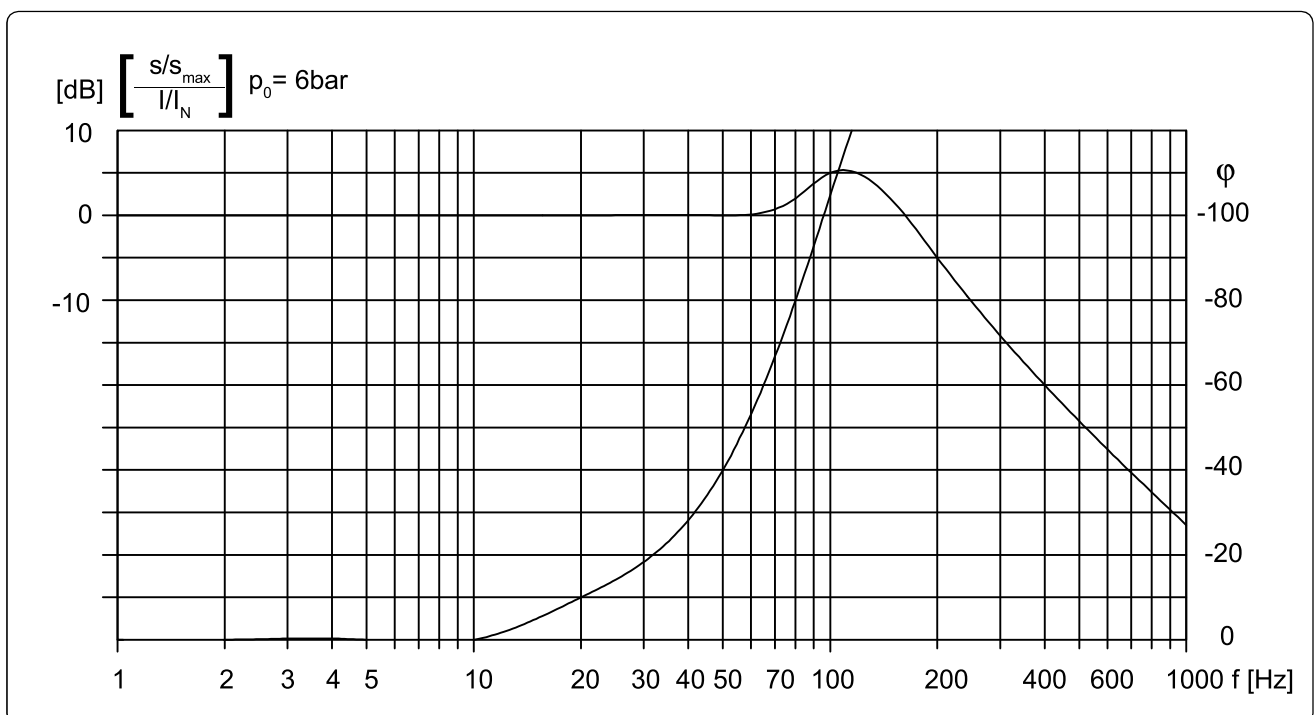

Specification subject to change without notice!

All rights reserved !

page no 3

available models				
1	PVM064/065	-020-	-1141-	0A
2	PVM064/065	-030-	-1151-	0A
3	PVM064/065	-050-	-1131-	0A
4	PVM064/065	-050-	-1141-	0A
5	PVM064/065	-080-	-1111-	0A

**model key:** PVM 0 0 0 - 0 0 0 - 0 0 0 0 , 0 X

*Pneumatic servovalve*

*Type code*

PVM064: sub-plate construction  
DIN ISO 5599 NG 2  
(holes for mounting screws different)  
PVM065: pipe-line connection R 1/2"

*rated flow*  
in Nm<sup>3</sup>/h at p<sub>v</sub> = 6bar, and Δp = 1bar per edge

020 - 20 Nm<sup>3</sup>/h  
030 - 30 Nm<sup>3</sup>/h  
050 - 50 Nm<sup>3</sup>/h  
080 - 80 Nm<sup>3</sup>/h

*code for type of sealing*

1 = Perbunan \*

\* further models on request.

*construction standard: A, B...*

*model number:*

0 = basic model  
1 = with pressure transducer  
2 = with position transducer

*code of size of overlap or underlap*

standard = 5% I<sub>N</sub> \*

*code of type of overlap or underlap*

0- standard  
1- overlap  
2- underlap  
3- T -port 30% bigger as P-port  
4- T -port 30% bigger as P-port, progressive curve  
5- T -port equal to P-port, progressive curve  
6-  
7-  
8-  
9- unsymmetrical overlap ( depends on type )

*code for rated current (torquemotor coil)*

1. R<sub>i</sub> - 27Ω I = ±400mA U<sub>v</sub> = 12V  
2. R<sub>i</sub> - 7Ω I = ±800mA U<sub>v</sub> = 6V

# dimensions of PVM 064

male connector MS 3102 E10 SL-3P  
female cable conn. CA 06 COM E10 SL-3S

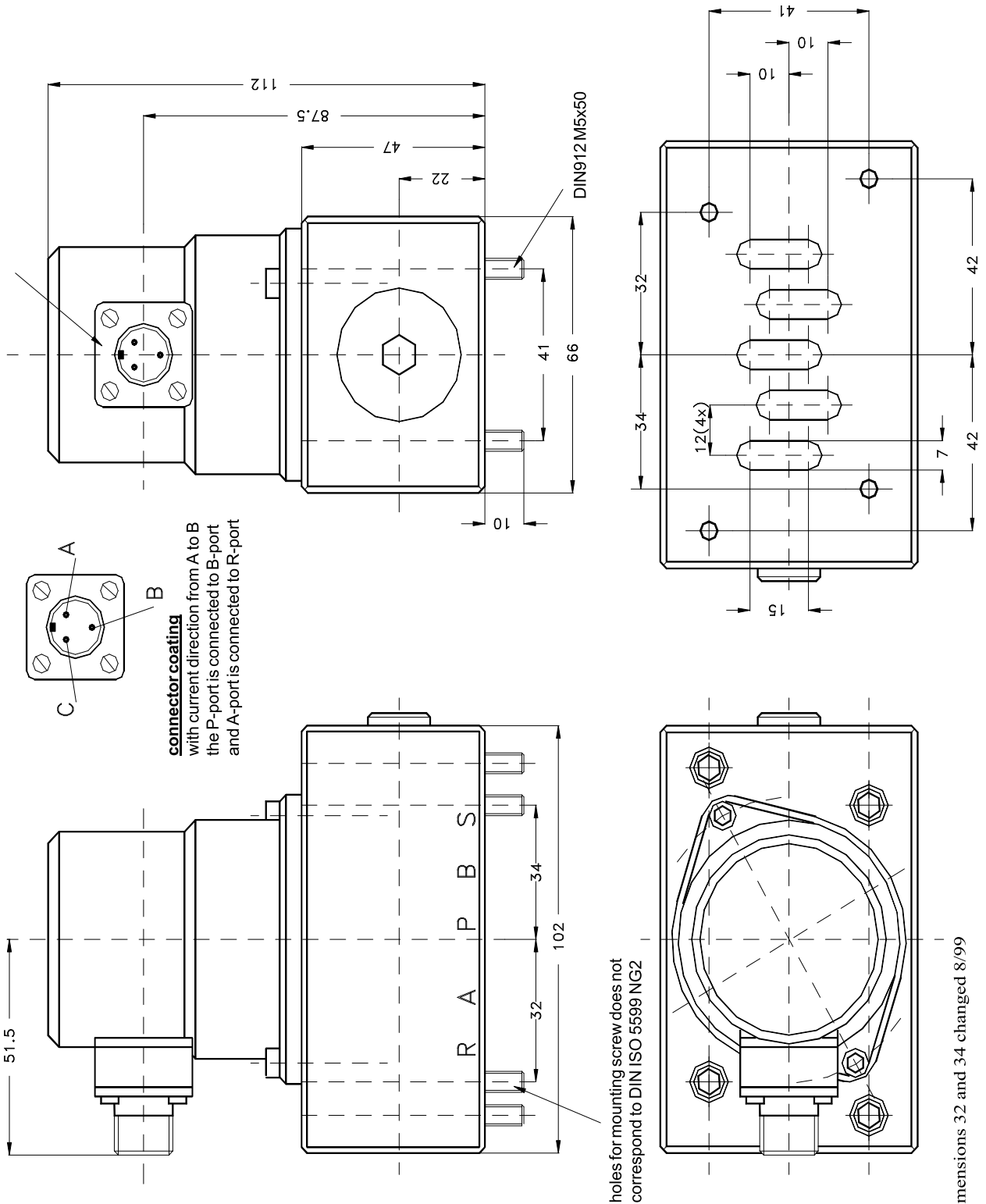

modification 1: dimensions 32 and 34 changed 8/99

**dimensions of PVM065**

